

SECTION MA
MAINTENANCE

A
B
C

CONTENTS

PRECAUTIONS	3		
Precautions for Supplemental Restraint System (SRS) "AIR BAG" and "SEAT BELT PRE-TENSIONER"	3	Changing Engine Oil	16
PREPARATION	4	Engine Oil Filter	17
Special Service Tools	4	REMOVAL	17
Commercial Service Tools	4	INSTALLATION	17
GENERAL MAINTENANCE	5	INSPECTION AFTER INSTALLATION	18
Explanation of General Maintenance	5	Changing Spark Plugs	18
General Maintenance	5	18
PERIODIC MAINTENANCE	7	INSPECTION AFTER REMOVAL	18
Introduction of Periodic Maintenance	7	INSTALLATION	19
Schedule 1	7	Checking EVAP Vapor Lines	19
EMISSION CONTROL SYSTEM MAINTENANCE	7	CHASSIS AND BODY MAINTENANCE	20
CHASSIS AND BODY MAINTENANCE	8	Changing In-cabin Microfilter	20
Schedule 2	9	Checking Exhaust System	20
EMISSION CONTROL SYSTEM MAINTENANCE	9	Checking CVT Fluid	20
CHASSIS AND BODY MAINTENANCE	10	FLUID LEVEL CHECK	20
RECOMMENDED FLUIDS AND LUBRICANTS	11	FLUID CONDITION CHECK	21
Fluids and Lubricants	11	Changing CVT Fluid	21
SAE Viscosity Number	12	Checking Clutch Fluid Level and Leaks	22
Anti-freeze Coolant Mixture Ratio	12	Checking Clutch System	22
ENGINE MAINTENANCE	13	Checking M/T Oil	22
Drive Belts	13	OIL LEAKAGE AND OIL LEVEL	22
Checking Drive Belts	13	Changing M/T Oil	22
Tension Adjustment	13	DRAINING	22
Changing Engine Coolant	13	FILLING	22
DRAINING ENGINE COOLANT	13	Checking A/T Fluid	22
REFILLING ENGINE COOLANT	14	Changing A/T Fluid	23
FLUSHING COOLING SYSTEM	15	Balancing Wheels	24
Inspection	15	Rotation	24
LEVEL CHECK	15	Checking Brake Fluid Level and Leaks	24
CHECKING COOLING SYSTEM FOR LEAKS... ..	15	Checking Brake Lines and Cables	24
Checking Fuel Lines	15	Changing Brake Fluid	25
Changing Air Cleaner Filter	16	Checking Disc Brake	25
REMOVAL	16	ROTOR	25
INSPECTION AFTER REMOVAL	16	CALIPER	25
INSTALLATION	16	PAD	25
		WHEEL CYLINDER	26
		LINING	26
		Axle and Suspension Parts	26
		Drive Shaft	27

D
E

F
G

H
I

J
K

MA

M

Lubricating Locks, Hinges and Hood Latch	27	and Adjusters	27
Checking Seat Belts, Buckles, Retractors, Anchors			

PRECAUTIONS

PRECAUTIONS

PFP:00001

Precautions for Supplemental Restraint System (SRS) “AIR BAG” and “SEAT BELT PRE-TENSIONER”

ELS002C6

The Supplemental Restraint System such as “AIR BAG” and “SEAT BELT PRE-TENSIONER”, used along with a front seat belt, helps to reduce the risk or severity of injury to the driver and front passenger for certain types of collision. This system includes seat belt switch inputs and dual stage front air bag modules. The SRS system uses the seat belt switches to determine the front air bag deployment, and may only deploy one front air bag, depending on the severity of a collision and whether the front occupants are belted or unbelted. Information necessary to service the system safely is included in the SRS and SB section of this Service Manual.

WARNING:

- To avoid rendering the SRS inoperative, which could increase the risk of personal injury or death in the event of a collision which would result in air bag inflation, all maintenance must be performed by an authorized NISSAN/INFINITI dealer.
- Improper maintenance, including incorrect removal and installation of the SRS, can lead to personal injury caused by unintentional activation of the system. For removal of Spiral Cable and Air Bag Module, see the SRS section.
- Do not use electrical test equipment on any circuit related to the SRS unless instructed to in this Service Manual. SRS wiring harnesses can be identified by yellow and/or orange harnesses or harness connectors.

A
B
C
D
E
F
G
H
I
J
K
MA
M

MA

PREPARATION

PREPARATION

PF0:00002

Special Service Tools

ELS001WN

The actual shapes of Kent-Moore tools may differ from those of special service tools illustrated here.

Tool number (Kent-Moore No.) Tool name	Description
KV10115801 (J-38956) Oil filter wrench	Removing and installing oil filter a: 64.3 mm (2.531 in)
KV991J0010 (J-23688) Engine coolant refractometer	Checking concentration of ethylene glycol in engine coolant
KV991J0070 (J-45695) Coolant Refill Tool	Refilling engine cooling system

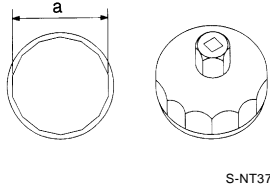

S-NT375

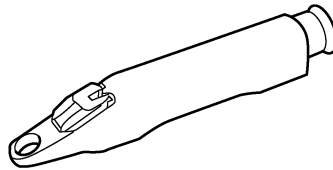

WBIA0539E

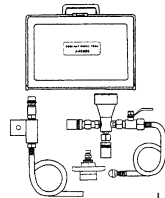

LMA053

Commercial Service Tools

ELS001WO

(Kent-Moore No.) Tool name	Description
Power tool	Loosening bolts and nuts
Spark plug wrench	Removing and installing spark plug

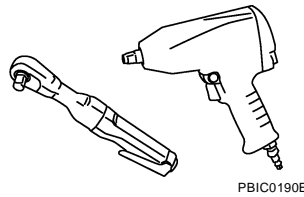

PBIC0190E

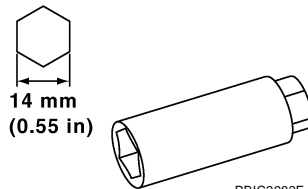

PBIC2982E

GENERAL MAINTENANCE

GENERAL MAINTENANCE

PFP:00000

Explanation of General Maintenance

ELS001YB

General Maintenance

ELS001YC

General maintenance includes those items which should be checked during the normal day-to-day operation of the vehicle. They are essential if the vehicle is to continue operating properly. The owners can perform checks and inspections themselves or they can have their NISSAN dealers do them.

OUTSIDE THE VEHICLE

The maintenance items listed here should be performed from time to time, unless otherwise specified.

Item		Reference page
Tires	Check the pressure including the spare, at least once a month and always prior to a long distance trip. Adjust to the specified pressure if necessary. Check carefully for damage, cuts or excessive wear.	WT-29, "Tire"
Wheel nuts	When checking the tires, make sure no nuts are missing, and check for any loose nuts. Tighten if necessary.	WT-6, "Rotation"
Windshield	Clean the windshield on a regular basis. Check the windshield at least every six months for cracks or other damage. Repair as necessary.	—
Tire rotation	Tires should be rotated every 12,000 km (7,500 miles).	WT-6, "Rotation"
Transmitter components in tire pressure monitoring system	Replace grommet seal, valve core and cap of the transmitter in TPMS every tire replacement by reaching wear limit of tire.	WT-7, "TIRE PRESSURE MONITORING SYSTEM"
Wheel alignment and balance	If the vehicle pulls to either side while driving on a straight and level road, or if you detect uneven or abnormal tire wear, there may be a need for wheel alignment. If the steering wheel or seat vibrates at normal highway speeds, wheel balancing may be needed.	FSU-6, "Wheel Alignment Inspection" and WT-6, "Balancing Wheels"
Windshield wiper blades	Check for cracks or wear if they do not wipe properly.	—
Doors and engine hood	Check that all doors and the engine hood operate smoothly as well as the trunk lid and back hatch. Also make sure that all latches lock securely. Lubricate if necessary. Make sure that the secondary latch keeps the hood from opening when the primary latch is released. When driving in areas using road salt or other corrosive materials, check lubrication frequently.	MA-27, "Lubricating Locks, Hinges and Hood Latch"
Lamps	Make sure that the headlamps, stop lamps, tail lamps, turn signal lamps, and other lamps are all operating properly and installed securely. Also check headlamp aim. Clean the headlamps on a regular basis.	—

INSIDE THE VEHICLE

The maintenance items listed here should be checked on a regular basis, such as when performing periodic maintenance, cleaning the vehicle, etc.

Item		Reference page
Warning lamps and buzzers/chimes	Make sure that all warning lamps and buzzers/chimes are operating properly.	—
Windshield wiper and washer	Check that the wipers and washer operate properly and that the wipers do not streak.	—
Windshield defroster	Check that the air comes out of the defroster outlets properly and in sufficient quantity when operating the heater or air conditioning.	—
Steering wheel	Check that it has the specified play. Be sure to check for changes in the steering condition, such as excessive play, hard steering or strange noises. Free play: Less than 35 mm (1.38 in)	—
Seats	Check seat position controls such as seat adjusters, seat back recliner, etc. to make sure they operate smoothly and that all latches lock securely in every position. Check that the head restraints move up and down smoothly and that the locks (if equipped) hold securely in all latched positions. Check that the latches lock securely for folding-down rear seat backs.	—

GENERAL MAINTENANCE

Item		Reference page
Seat belts	Check that all parts of the seat belt system (e.g. buckles, anchors, adjusters and retractors) operate properly and smoothly and are installed securely. Check the belt webbing for cuts, fraying, wear or damage.	MA-27, "Checking Seat Belts, Buckles, Retractors, Anchors and Adjusters"
Accelerator pedal	Check the pedal for smooth operation and make sure the pedal does not catch or require uneven effort. Keep the floor mats away from the pedal.	—
Clutch pedal	Make sure the pedal operates smoothly and check that it has the proper free play.	MA-22
Brakes	Check that the brake does not pull the vehicle to one side when applied.	—
Brake pedal and booster	Check the pedal for smooth operation and make sure it has the proper distance under it when depressed fully. Check the brake booster function. Be sure to keep floor mats away from the pedal.	BR-6, "Inspection and Adjustment" and BR-19, "On-board Inspection"
Parking brake	Check that the lever has the proper travel and make sure that the vehicle is held securely on a fairly steep hill when only the parking brake is applied.	PB-4, "INSPECTION"
Automatic transaxle "Park" mechanism	Check that the lock release button on the selector lever operates properly and smoothly. On a fairly steep hill check that the vehicle is held securely with the selector lever in the "P" position without applying any brakes.	—
CVT P (Park) position mechanism	On a fairly steep hill check that the vehicle is held securely with the selector lever in the "P" position without applying any brakes.	—

UNDER THE HOOD AND VEHICLE

The maintenance items listed here should be checked periodically (e.g. each time you check the engine oil or refuel).

Item		Reference page
Windshield washer fluid	Check that there is adequate fluid in the tank.	—
Engine coolant level	Check the coolant level when the engine is cold.	CO-8, "LEVEL CHECK"
A/C condenser, radiator and hoses	Check the front of the condenser and radiator and clean off any dirt, insects, leaves, etc., that may have accumulated. Make sure the radiator hoses have no cracks, deformation, deterioration or loose connections.	—
Brake and clutch fluid levels	Make sure that the brake and clutch fluid levels are between the "MAX" and "MIN" lines on the reservoirs.	BR-9, "CHECKING BRAKE FLUID LEVEL" and MA-22, "Checking Clutch Fluid Level and Leaks"
Battery	Check the fluid level in each cell. It should be between the "MAX" and "MIN" lines. Vehicles operated in high temperatures or under severe conditions require frequent checks of the battery fluid level.	—
Engine drive belts	Make sure that no belt is frayed, worn, cracked or oily.	MA-13
Engine oil level	Check the level on the dipstick after parking the vehicle on a level spot and turning off the engine.	LU-5, "ENGINE OIL LEVEL"
Automatic transaxle fluid level	Check the level on the dipstick after putting the selector lever in "P" with the engine idling.	MA-20 and MA-22
Exhaust system	Make sure there are no loose supports, cracks or holes. If the sound of the exhaust seems unusual or there is a smell of exhaust fumes, immediately locate the trouble and correct it.	MA-20
Underbody	The underbody is frequently exposed to corrosive substances such as those used on icy roads or to control dust. It is very important to remove these substances, otherwise rust will form on the floor pan, frame, fuel lines and around the exhaust system. At the end of winter, the underbody should be thoroughly flushed with plain water, being careful to clean those areas where mud and dirt can easily accumulate.	—
Fluid leaks	Check under the vehicle for fuel, oil, water or other fluid leaks after the vehicle has been parked for a while. Water dripping from the air conditioner after use is normal. If you should notice any leaks or gasoline fumes are evident, check for the cause and correct it immediately.	—

PERIODIC MAINTENANCE

PERIODIC MAINTENANCE

PFP:00026

Introduction of Periodic Maintenance

ELS001YD

Two different maintenance schedules are provided, and should be used, depending upon the conditions in which the vehicle is mainly operated. **After 60,000 miles (96,000 km) or 48 months, continue the periodic maintenance at the same mileage/time intervals.**

Schedule 1	Follow Periodic Maintenance Schedule 1 if your driving habits frequently includes one or more of the following driving conditions: <ul style="list-style-type: none"> ● Repeated short trips of less than 5 miles (8 km). ● Repeated short trips of less than 10 miles (16 km) with outside temperatures remaining below freezing. ● Operating in hot weather in stop-and-go "rush hour" traffic. ● Extensive idling and/or low speed driving for long distances, such as police, taxi or door-to-door delivery use. ● Driving in dusty conditions. ● Driving on rough, muddy, or salt spread roads. ● Towing a trailer, using a camper or a car-top carrier. 	Emission Control System Maintenance	MA-7
		Chassis and Body Maintenance	MA-8
Schedule 2	Follow Periodic Maintenance Schedule 2 if none of the driving conditions shown in Schedule 1 apply to your driving habits.	Emission Control System Maintenance	MA-9
		Chassis and Body Maintenance	MA-10

Schedule 1

ELS001YE

EMISSION CONTROL SYSTEM MAINTENANCE

Abbreviations: R = Replace. I = Inspect. Correct or replace if necessary. []: At the mileage intervals only

MAINTENANCE OPERATION		MAINTENANCE INTERVAL								Reference Section - Page or - Content Title
Perform at number of miles, kilometers or months, whichever comes first.	Miles x 1,000 (km x 1,000) Months	3.75 (6) 3	7.5 (12) 6	11.25 (18) 9	15 (24) 12	18.75 (30) 15	22.5 (36) 18	26.25 (42) 21	30 (48) 24	
Drive belt	NOTE (1)									MA-13
Air cleaner filter	NOTE (2)								[R]	MA-16
EVAP vapor lines									I*	MA-19
Fuel lines									I*	MA-15
Fuel filter	NOTE (3)									—
Engine coolant	NOTE (4)									MA-13
Engine oil		R	R	R	R	R	R	R	R	MA-16
Engine oil filter (Use genuine oil filter or equivalent)		R	R	R	R	R	R	R	R	MA-17
Spark plugs (Iridium/platinum-tipped type)		Replace every 105,000 miles (169,000 km)								MA-18
Intake and exhaust valve clearance	NOTE (5)									EM-108, "Valve Clearance"

PERIODIC MAINTENANCE

Abbreviations: R = Replace. I = Inspect. Correct or replace if necessary. []: At the mileage intervals only

MAINTENANCE OPERATION		MAINTENANCE INTERVAL								Reference Section - Page or - Content Title	
Perform at number of miles, kilometers or months, whichever comes first.	Miles x 1,000 (km x 1,000) Months	33.75 (54) 27	37.5 (60) 30	41.25 (66) 33	45 (72) 36	48.75 (78) 39	52.5 (84) 42	56.25 (90) 45	60 (96) 48		
Drive belt	NOTE (1)									I*	MA-13
Air cleaner filter	NOTE (2)									[R]	MA-16
EVAP vapor lines										I*	MA-19
Fuel lines										I*	MA-15
Fuel filter	NOTE (3)										—
Engine coolant	NOTE (4)									R*	MA-13
Engine oil		R	R	R	R	R	R	R	R		MA-16
Engine oil filter (Use genuine oil filter or equivalent)		R	R	R	R	R	R	R	R		MA-17
Spark plugs (Iridium/platinum-tipped type)		Replace every 105,000 miles (169,000 km)									MA-18
Intake and exhaust valve clearance	NOTE (5)										EM-108

(1) After 60,000 miles (96,000 km) or 48 months, inspect every 15,000 miles (24,000 km) or 12 months. Replace the drive belts if found damaged.

(2) If operating mainly in dusty conditions, more frequent maintenance may be required.

(3) Maintenance-free item. For service procedures, go to the FL section.

(4) After 60,000 miles (96,000 km) or 48 months, replace every 30,000 miles (48,000 km) or 24 months.

(5) If valve noise increases, inspect valve clearance.

* Maintenance items and intervals with "*" are recommended by NISSAN for reliable vehicle operation. The owner need not perform such maintenance in order to maintain the emission warranty or manufacturer recall liability. Other maintenance items and intervals are required.

CHASSIS AND BODY MAINTENANCE

Abbreviations: R = Replace. I = Inspect. Correct or replace if necessary. L = Lubricate.

MAINTENANCE OPERATION		MAINTENANCE INTERVAL								Reference Section - Page or - Content Title
Perform at number of miles, kilometers or months, whichever comes first.	Miles x 1,000 (km x 1,000) Months	3.75 (6) 3	7.5 (12) 6	11.25 (18) 9	15 (24) 12	18.75 (30) 15	22.5 (36) 18	26.25 (42) 21	30 (48) 24	
Brake lines & cables					I				I	MA-24
Brake pads, rotors, drums & linings			I		I		I		I	MA-25
Manual transaxle oil or automatic transaxle fluid	NOTE (1)				I				I	MA-20 , MA-22 or MA-22
CVT fluid	NOTE (2)				I				I	
Steering gear & linkage, axle & suspension parts			I		I		I		I	MA-26 , PS-13
Tire rotation	NOTE (3)									WT-6
Front drive shaft boots			I		I		I		I	MA-27

PERIODIC MAINTENANCE

MAINTENANCE OPERATION		MAINTENANCE INTERVAL								Reference Section - Page or - Content Title
Perform at number of miles, kilometers or months, whichever comes first.	Miles x 1,000 (km x 1,000) Months	3.75 (6) 3	7.5 (12) 6	11.25 (18) 9	15 (24) 12	18.75 (30) 15	22.5 (36) 18	26.25 (42) 21	30 (48) 24	
Exhaust system			I		I		I		I	MA-20
In-cabin microfilter					R				R	MA-20

Abbreviations: R = Replace. I = Inspect. Correct or replace if necessary. L = Lubricate.

MAINTENANCE OPERATION		MAINTENANCE INTERVAL								Reference Section - Page or - Content Title
Perform at number of miles, kilometers or months, whichever comes first.	Miles x 1,000 (km x 1,000) Months	33.75 (54) 27	37.5 (60) 30	41.25 (66) 33	45 (72) 36	48.75 (78) 39	52.5 (84) 42	56.25 (90) 45	60 (96) 48	
Brake lines & cables					I				I	MA-24
Brake pads, rotors, drums & linings			I		I		I		I	MA-25
Manual transaxle oil or automatic transaxle fluid	NOTE (1)				I				I	MA-22 or MA-22
CVT fluid	NOTE (2)				I				I	MA-20
Steering gear & linkage, axle & suspension parts			I		I		I		I	MA-26 , PS-13
Tire rotation	NOTE (3)									MA-24
Front drive shaft boots			I		I		I		I	MA-27
Exhaust system			I		I		I		I	MA-20
In-cabin microfilter					R				R	MA-20

(1) If towing a trailer, using a camper or a car-top carrier, or driving on rough or muddy roads, change (not just inspect) oil (exc. LSD) at every 30,000 miles (48,000 km) or 24 months, and change LSD gear oil every 15,000 miles (24,000 km) or 12 months.

(2) If towing a trailer, using a camper or a car-top carrier, or driving on rough or muddy roads, inspect CVT fluid deterioration with CONSULT-II every 60,000 miles (96,000 km), then change CVT fluid NS-2 if necessary. If CONSULT-II is not available, change (not just inspect) CVT fluid NS-2 every 60,000 miles (96,000 km). **Using transmission fluid other than Genuine NISSAN CVT Fluid NS-2 will damage the CVT, which is not covered by the NISSAN new vehicle limited warranty.**

(3) Refer to "Tire rotation" under the "GENERAL MAINTENANCE" heading earlier in this section.

Schedule 2 EMISSION CONTROL SYSTEM MAINTENANCE

ELS001YF

Abbreviations: R = Replace. I = Inspect. Correct or replace if necessary. []: At the mileage intervals only

MAINTENANCE OPERATION		MAINTENANCE INTERVAL								Reference Section - Page or - Content Title
Perform at number of miles, kilometers or months, whichever comes first.	Miles x 1,000 (km x 1,000) Months	7.5 (12) 6	15 (24) 12	22.5 (36) 18	30 (48) 24	37.5 (60) 30	45 (72) 36	52.5 (84) 42	60 (96) 48	
Drive belt	NOTE (1)								I*	MA-13
Air cleaner filter					[R]				[R]	MA-16
EVAP vapor lines					I*				I*	MA-19
Fuel lines					I*				I*	MA-15
Fuel filter	NOTE (2)									—
Engine coolant	NOTE (3)								R*	MA-13
Engine oil		R	R	R	R	R	R	R	R	MA-16
Engine oil filter (Use genuine oil filter or equivalent.)		R	R	R	R	R	R	R	R	MA-17

PERIODIC MAINTENANCE

MAINTENANCE OPERATION		MAINTENANCE INTERVAL								Reference Section - Page or - Content Title
	Miles x 1,000 (km x 1,000) Months	7.5 (12) 6	15 (24) 12	22.5 (36) 18	30 (48) 24	37.5 (60) 30	45 (72) 36	52.5 (84) 42	60 (96) 48	
Perform at number of miles, kilometers or months, whichever comes first.										
Spark plugs (Iridium/platinum-tipped type)		Replace every 105,000 miles (169,000 km)								MA-18
Intake and exhaust valve clearance)	NOTE (4)									EM-108, "Valve Clearance"

(1) After 60,000 miles (96,000 km) or 48 months, inspect every 15,000 miles (24,000 km) or 12 months. Replace the drive belt if found damaged or if the auto belt tensioner reading reaches the maximum limit.

(2) Maintenance-free item.

(3) After 60,000 miles (96,000 km) or 48 months, replace every 30,000 miles (48,000 km) or 24 months.

(4) If valve noise increases, inspect valve clearance.

Maintenance items and intervals with "*" are recommended by NISSAN for reliable vehicle operation. The owner need not perform such maintenance in order to maintain the emission warranty or manufacturer recall liability. Other maintenance items and intervals are required.

CHASSIS AND BODY MAINTENANCE

Abbreviations: R = Replace. I = Inspect. Correct or replace if necessary. L = Lubricate.

MAINTENANCE OPERATION		MAINTENANCE INTERVAL								Reference Section - Page or - Content Title
	Miles x 1,000 (km x 1,000) Months	7.5 (12) 6	15 (24) 12	22.5 (36) 18	30 (48) 24	37.5 (60) 30	45 (72) 36	52.5 (84) 42	60 (96) 48	
Perform at number of miles, kilometers or months, whichever comes first.										
Brake lines & cables			I		I		I		I	MA-24
Brake pads, rotors, drums & linings			I		I		I		I	MA-25
Manual transaxle oil or automatic transaxle fluid			I		I		I		I	MA-22 or MA-22
CVT fluid	NOTE (1)		I		I		I		I	MA-20
Steering gear & linkage, axle & suspension parts					I				I	MA-26, PS-13
Tire rotation	NOTE (2)									MA-24
Front drive shaft boots			I		I		I		I	MA-27
Exhaust system					I				I	MA-20
In-cabin microfilter			R		R		R		R	MA-20

(1) Using transmission fluid other than Genuine NISSAN CVT Fluid NS-2 will damage the CVT, which is not covered by the NISSAN new vehicle limited warranty.

(2) Refer to "Tire rotation" under the "GENERAL MAINTENANCE" heading earlier in this section.

RECOMMENDED FLUIDS AND LUBRICANTS

RECOMMENDED FLUIDS AND LUBRICANTS

PF0:0000

Fluids and Lubricants

ELS001YG

Description		Capacity (Approximate)			Recommended Fluids/Lubricants
		Liter	US measure	Imp measure	
Fuel		52.0	13 3/4 gal	11 1/2 gal	Unleaded gasoline with an octane rating of at least 87 AKI (RON 91)
Engine oil Drain and refill	With oil filter change	3.9	4 1/8 qt	3 3/8 qt	<ul style="list-style-type: none"> ● Engine oil with API Certification Mark *1 ● Viscosity SAE 5W-30
	Without oil filter change	3.7	3 7/8 qt	3 1/4 qt	
Dry engine (engine overhaul)		4.9	5 1/8 qt	4 3/8 qt	
Cooling system (with reservoir at max level)		6.8	7 1/4 qt	6 qt	Genuine NISSAN Long Life Anti-freeze Coolant or equivalent
Manual transaxle fluid (MTF)		2.0	4 1/4 pt	3 1/2 pt	EFF XT4447 M+ 75W-80 or API GL-4, Viscosity SAE 75W-80
Automatic transaxle fluid (ATF)		7.9	8 3/8 qt	7 qt	Genuine NISSAN Matic "D" ATF (Continental U.S. and Alaska) or Canada NISSAN Automatic Transmission Fluid *2
CVT fluid		8.3	8 3/4 qt	7 1/4 qt	Genuine NISSAN CVT Fluid NS-2 *3
Brake and clutch fluid		—	—	—	Genuine NISSAN Super Heavy Duty Brake Fluid*4 or equivalent DOT 3 (US FMVSS No. 116)
Multi-purpose grease		—	—	—	NLGI No. 2 (Lithium soap base)
Windshield washer fluid		4.5	4 3/4 qt	4 qt	Genuine NISSAN Windshield Washer Concentrate Cleaner & Anti-Freeze or equivalent
Air conditioning system refrigerant		0.45 ± 0.05 kg	0.99 ± 0.11 lb	0.99 ± 0.11 lb	HFC-134a (R-134a) *5
Air conditioning system oil	Type 1	120 m ℓ	4.1 fl oz	4.2 fl oz	NISSAN A/C System Lubricant Type R or equivalent *5
	Type 2	100 m ℓ	3.4 fl oz	3.5 fl oz	NISSAN A/C System Lubricant Type S or equivalent *5

*1: For further details, see "Engine Oil Recommendation".

*2: DEXRON™ III / MERCON™, or equivalent may also be used. Outside the continental United States and Alaska contact a NISSAN dealership for more information regarding suitable fluids, including recommended brand(s) of DEXRON™ III / MERCON™ Automatic Transmission Fluid.

***3: Using transaxle fluid other than Genuine NISSAN CVT Fluid NS-2 will damage the CVT, which is not covered by the NISSAN new vehicle limited warranty.**

*4: Available in mainland U.S.A. through your NISSAN dealer.

*5: For further details, see "Air conditioner specification label".

RECOMMENDED FLUIDS AND LUBRICANTS

SAE Viscosity Number

ELS001YH

NISSAN recommends the use of an energy conserving oil in order to improve fuel economy. Select only engine oils that meet the American Petroleum Institute (API) certification and International Lubrication Standardization and Approval Committee (ILSAC) certification and SAE viscosity standard. These oils have the API certification mark on the front of the container. Oils which do not have the specified quality label should not be used as they could cause engine damage.

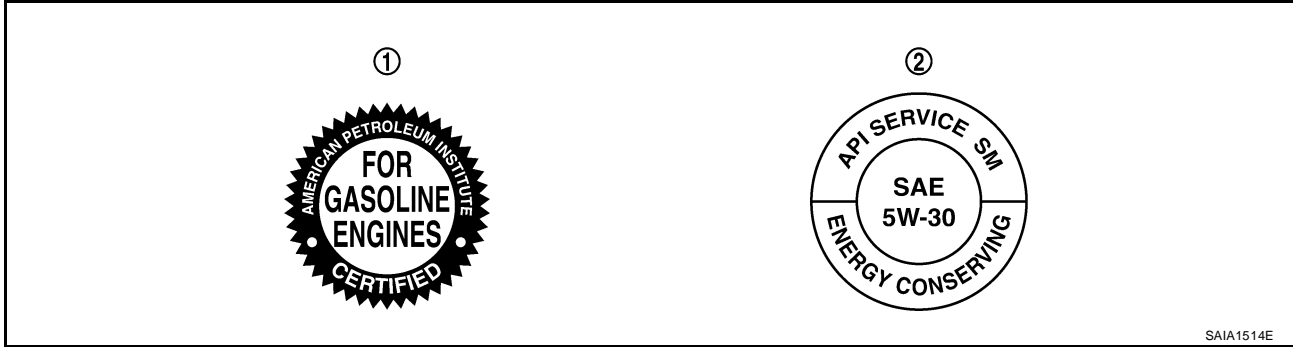

1. API certification mark

2. API service symbol

Anti-freeze Coolant Mixture Ratio

ELS001YI

The engine cooling system is filled at the factory with a high-quality, long life, year-round, anti-freeze coolant solution. The anti-freeze solution contains rust and corrosion inhibitors. Therefore, additional cooling system additives are not necessary.

Maximum outside temperature		Genuine NISSAN Anti-freeze Coolant or equivalent	Demineralized water or distilled water
°C	°F		
-35	-30	50%	50%

CAUTION:

- When adding or replacing coolant, be sure to use only a Genuine NISSAN Long Life Anti-Freeze coolant or equivalent with the proper mixture ratio.
- The use of other types of coolant solutions may damage the engine cooling system.

ENGINE MAINTENANCE

PFP:00100

Drive Belts

ELS001XU

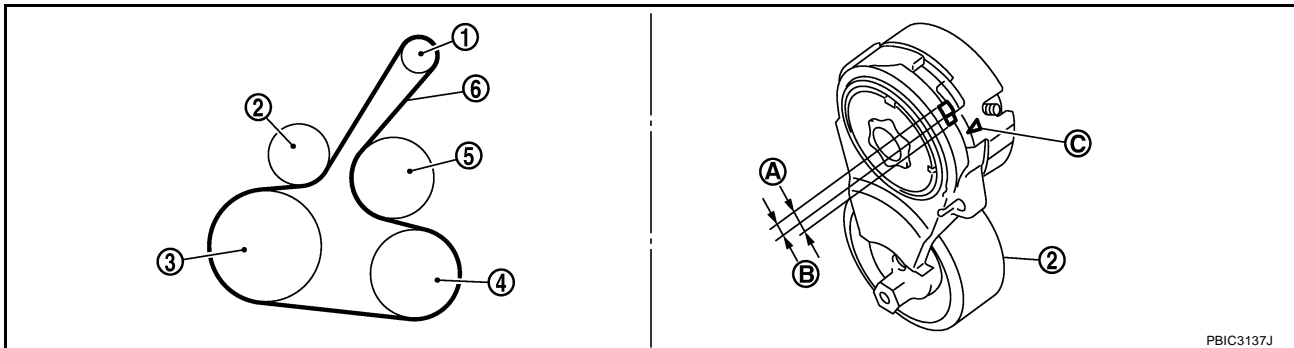

- | | | |
|--|---|----------------------|
| 1. Alternator | 2. Drive belt auto-tensioner | 3. Crankshaft pulley |
| 4. A/C compressor (models with A/C)
Idler pulley (models without A/C) | 5. Water pump | 6. Drive belt |
| A. Possible use range | B. Range when new drive belt is installed | C. Indicator |

Checking Drive Belts

ELS001XV

WARNING:

Be sure to perform this step when the engine is stopped.

- Make sure that the indicator (notch on fixed side) of drive belt auto-tensioner is within the possible use range (A).

NOTE:

- Check the drive belt auto-tensioner indication when the engine is cold.
- When new drive belt is installed, the indicator (notch on fixed side) should be within the range (B) in the figure.
- Visually check entire drive belt for wear, damage or cracks.
- If the indicator (notch on fixed side) is out of the possible use range or belt is damaged, replace drive belt.

Tension Adjustment

ELS001XW

Belt tension is not necessary, as it is automatically adjusted by drive belt auto-tensioner.

Changing Engine Coolant

ELS001XX

WARNING:

- To avoid being scalded, do not change engine coolant when engine is hot.
- Wrap a thick cloth around radiator cap and carefully remove the cap. First, turn the cap a quarter of a turn to release built-up pressure. Then turn the cap all the way.
- Be careful not to allow engine coolant to contact drive belt.

DRAINING ENGINE COOLANT

1. Open radiator drain plug (1) at the bottom of radiator, and then remove radiator cap.

- ⇐ Vehicle front

When drain all of engine coolant in the system, open water drain plug on cylinder block. Refer to [EM-78, "CYLINDER BLOCK"](#).

CAUTION:

- Perform this step when engine is cold.
- Do not spill engine coolant on drive belt.

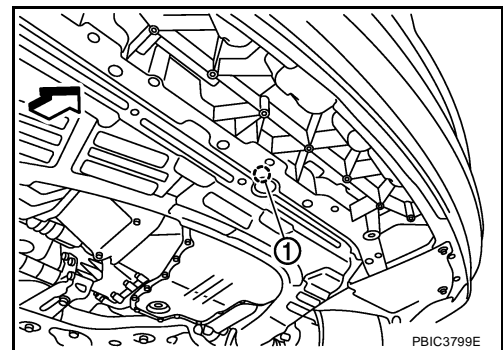

2. Remove reservoir tank as necessary, and drain engine coolant and clean reservoir tank before installing. Refer to [CO-11, "RADIATOR"](#).
3. Check drained engine coolant for contaminants such as rust, corrosion or discoloration.

ENGINE MAINTENANCE

If contaminated, flush the engine cooling system. Refer to [MA-15, "FLUSHING COOLING SYSTEM"](#) .

REFILLING ENGINE COOLANT

1. Install reservoir tank if removed. Refer to [CO-11, "RADIATOR"](#) .
2. Install radiator drain plug.
 - If water drain plug on cylinder block is removed, close and tighten it. Refer to [EM-78, "CYLINDER BLOCK"](#) .

CAUTION:

Be sure to clean radiator drain plug and install with new O-ring. Refer to [CO-11, "Components"](#) .

3. Make sure that each hose clamp has been firmly tightened.

4. Remove air duct assembly. Refer to [EM-16, "AIR CLEANER AND AIR DUCT"](#) .

5. Disconnect heater hose (1) at position (←) as shown.

- ← Front
- Enhance heater hose as high as possible.

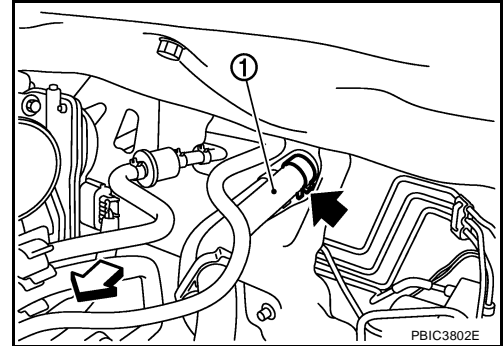

6. Fill radiator and reservoir tank to specified level.

- Pour engine coolant through engine coolant filler neck slowly of less than 2 ℓ (2 1/8 US qt, 1-3/4 Imp qt) a minute to allow air in system to escape.
- Use NISSAN Genuine Engine Coolant or equivalent mixed with water (distilled or demineralized). Fill cooling system to specification. Refer to [MA-11, "RECOMMENDED FLUIDS AND LUBRICANTS"](#).
- When engine coolant overflows disconnected heater hose, connect heater hose, and continue filling the engine coolant, if heater hose is disconnected.

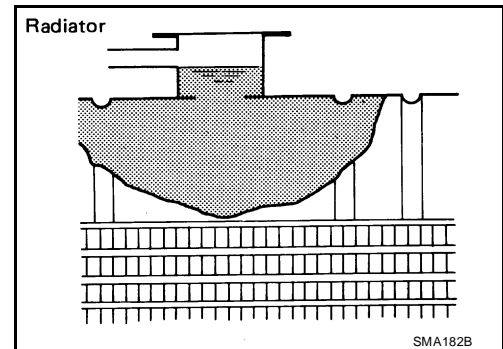

7. Install radiator cap.

8. Install air duct assembly. Refer to [EM-16, "AIR CLEANER AND AIR DUCT"](#) .

9. Warm up until opening thermostat. Standard for warming-up time is approximately 10 minutes at 3,000 rpm.

- Make sure thermostat opening condition by touching radiator hose (lower) to see a flow of warm water.

CAUTION:

Watch water temperature gauge so as not to overheat the engine.

10. Stop engine and cool down to less than approximately 50°C (122°F).

- Cool down using fan to reduce the time.
- If necessary, refill radiator up to filler neck with engine coolant.

11. Refill reservoir tank to "MAX" level line with engine coolant.

12. Repeat steps 6 through 10 two or more times with radiator cap installed until engine coolant level no longer drops.

13. Check cooling system for leaks with engine running.

14. Warm up engine, and check for sound of engine coolant flow while running engine from idle up to 3,000 rpm with heater temperature controller set at several position between "COOL" and "WARM".

- Sound may be noticeable at heater unit.

15. Repeat step 14 three times.

16. If sound is heard, bleed air from cooling system by repeating steps 6 through 10 until engine coolant level no longer drops.

ENGINE MAINTENANCE

FLUSHING COOLING SYSTEM

1. Install reservoir tank if removed. Refer to [CO-11, "RADIATOR"](#) .
 2. Install radiator drain plug.
 - If water drain plug on cylinder block is removed, close and tighten it. Refer to [EM-78, "CYLINDER BLOCK"](#) .
- CAUTION:**
Be sure to clean radiator drain plug and install with new O-ring. Refer to [CO-11, "Components"](#) .
3. Fill radiator and reservoir tank with water and reinstall radiator cap.
 4. Run engine and warm it up to normal operating temperature.
 5. Rev engine two or three times under no-load.
 6. Stop engine and wait until it cools down.
 7. Drain water from the cooling system. Refer to [MA-13, "DRAINING ENGINE COOLANT"](#) .
 8. Repeat steps 1 through 7 until clear water begins to drain from radiator.

Inspection LEVEL CHECK

ELS0020L

- Check if the reservoir tank engine coolant level is within the "MIN" to "MAX" range when engine is cool.
- Adjust the engine coolant level as necessary.

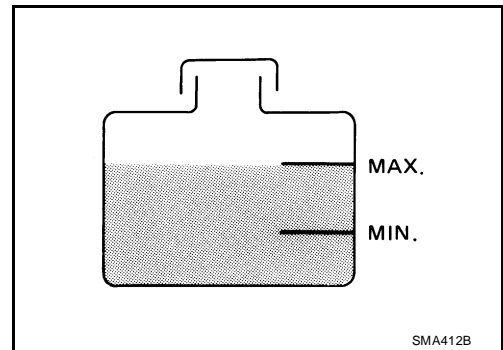

CHECKING COOLING SYSTEM FOR LEAKS

To check for leaks, apply pressure to the cooling system using Tool.

Tool number : EG17650301 (J-33984-A)

Testing pressure : 157 kPa (1.6 kg/cm² , 23 psi)

WARNING:

Never remove the radiator cap when the engine is hot. Serious burns could occur from high pressure coolant escaping from the radiator.

CAUTION:

Higher pressure than specified may cause radiator damage.

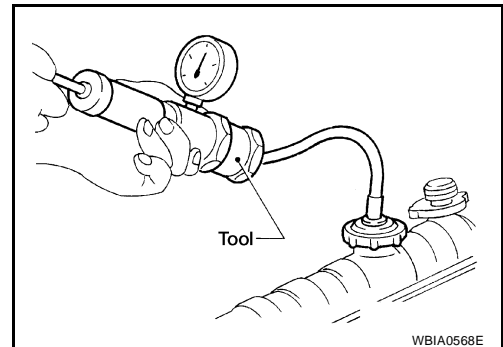

Checking Fuel Lines

ELS001XZ

Inspect fuel lines, fuel filler cap and fuel tank for improper attachment, leaks, cracks, damage, loose connections, chafing or deterioration.

If necessary, repair or replace damaged parts.

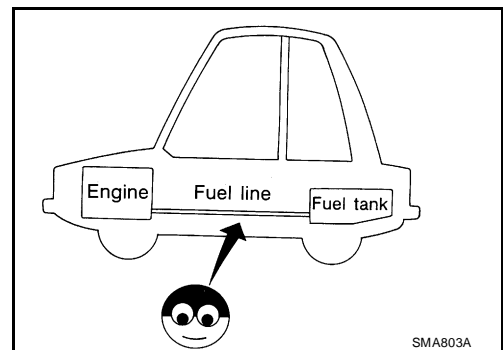

ENGINE MAINTENANCE

ELS001Y0

Changing Air Cleaner Filter REMOVAL

1. Push the tabs (A) of both ends of the air cleaner cover (1) into the inside (B).
2. Pull up the air cleaner cover forward (C) and remove it.

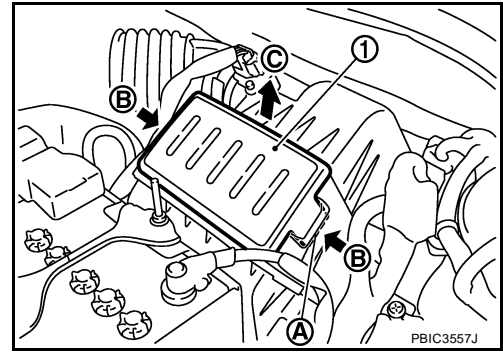

3. Remove the air cleaner filter (1) and holder (2) assembly from the air cleaner case.
4. Remove the air cleaner filter from the holder.

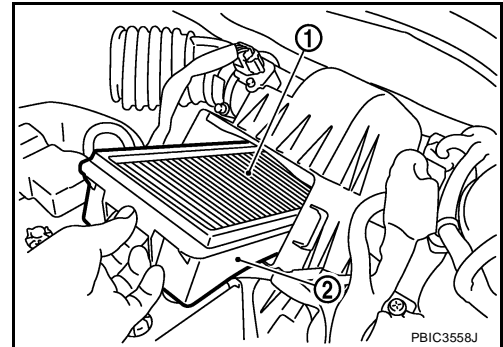

INSPECTION AFTER REMOVAL

It is necessary to clean air cleaner filter or replace it at the recommended intervals, more often under dusty driving conditions. Refer to [MA-7, "PERIODIC MAINTENANCE"](#).

- Blow air into the back side of air cleaner filter until no any object sprays out.

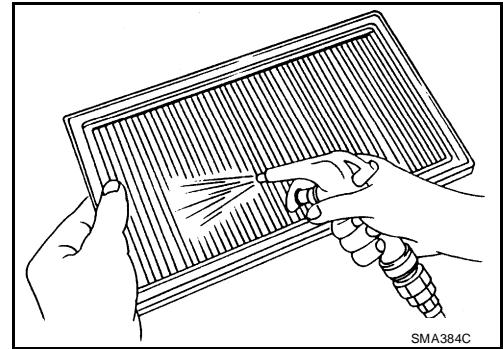

INSTALLATION

Note the following, and install in the reverse order of removal.

- Install the air cleaner cover (1) in the direction shown in the figure.
- Air cleaner filter (2)
- Holder (3)

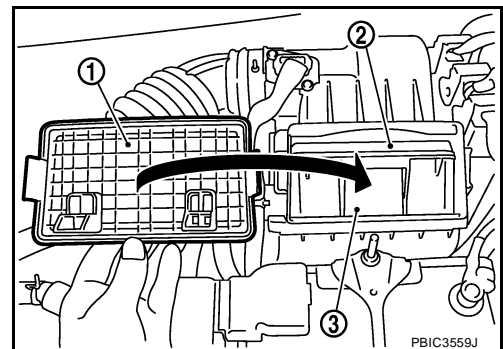

Changing Engine Oil

ELS0020M

WARNING:

- Be careful not to burn yourself, as engine oil may be hot.

ENGINE MAINTENANCE

- **Prolonged and repeated contact with used engine oil may cause skin cancer; try to avoid direct skin contact with used engine oil. If skin contact is made, wash thoroughly with soap or hand cleaner as soon as possible.**
1. Warm up engine, park vehicle on a level surface and check for engine oil leakage from engine components. Refer to [LU-5, "ENGINE OIL LEAKAGE"](#) .
 2. Stop engine and wait for 10 minutes.
 3. Loosen oil filler cap (1) and then remove drain plug (2).
 - Oil filter (3)
 - ↶ Vehicle front
 4. Drain engine oil.
 5. Install drain plug (2) with new washer. Refer to [EM-24, "OIL PAN"](#)
CAUTION:
Be sure to clean drain plug (2) and install with new washer.
 6. Refill with new engine oil. Refer to [MA-11, "RECOMMENDED FLUIDS AND LUBRICANTS"](#) .
CAUTION:
 - **The refill capacity depends on the engine oil temperature and drain time. Use these specifications for reference only.**
 - **Always use oil level gauge to determine the proper amount of engine oil in the engine.**
 7. Warm up engine and check area around drain plug (2) and oil filter (3) for engine oil leakage.
 8. Stop engine and wait for 10 minutes.
 9. Check the engine oil level. Refer to [LU-5, "ENGINE OIL LEVEL"](#)

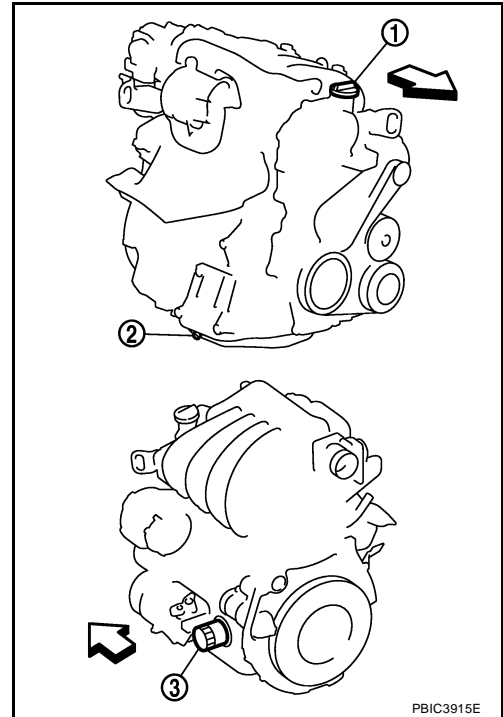

PBIC3915E

ELS0020N

Engine Oil Filter REMOVAL

1. Remove oil filter using Tool (A).
Tool number : KV10115801 (J-38956)
 - ↶ Front
CAUTION:
 - **Oil filter is provided with relief valve. Use Genuine NISSAN Oil Filter or equivalent.**
 - **Be careful not to get burned when engine and engine oil may be hot.**
 - **When removing, prepare a shop cloth to absorb any engine oil leakage or spillage.**
 - **Do not allow engine oil to adhere to drive belt.**
 - **Completely wipe off any engine oil that adheres to engine and vehicle.**

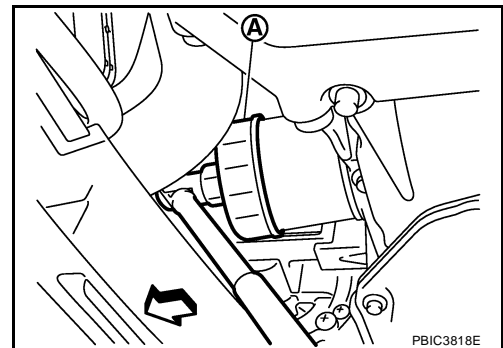

PBIC3818E

INSTALLATION

1. Remove foreign materials adhering to the oil filter installation surface.

ENGINE MAINTENANCE

2. Apply new engine oil to the oil seal contact surface of new oil filter.

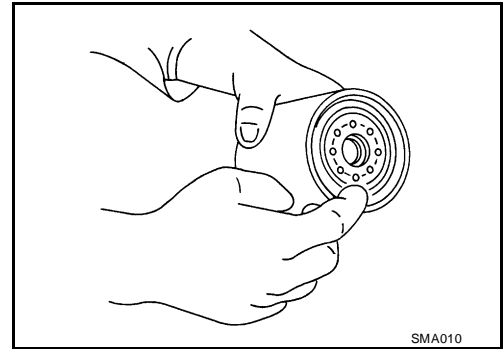

3. Screw oil filter manually until it touches the installation surface, then tighten it by 2/3 turn. Or tighten to specification.

Oil filter: : 17.7 N·m (1.8 kg·m, 13 ft·lb)

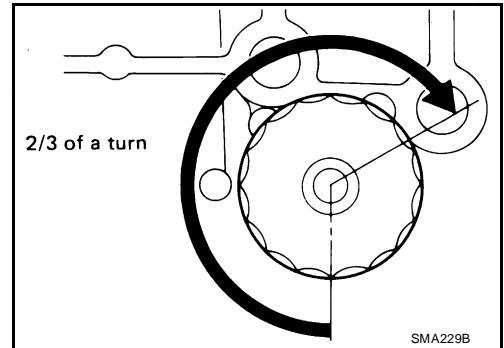

INSPECTION AFTER INSTALLATION

1. Check the engine oil level. Refer to [LU-5, "ENGINE OIL LEVEL"](#) .
2. Start engine, and make sure there is no leaks of engine oil.
3. Stop engine and wait for 10 minutes.
4. Check the engine oil level and adjust engine oil. Refer to [LU-5, "ENGINE OIL LEVEL"](#) .

Changing Spark Plugs

ELS00200

1. Remove intake manifold. Refer to [EM-18, "INTAKE MANIFOLD"](#) .
2. Remove ignition coil.

CAUTION:

- Handle ignition coil carefully and avoid impacts.
- Never disassemble.

3. Remove spark plug using suitable tool.

CAUTION:

Never drop or shock it.

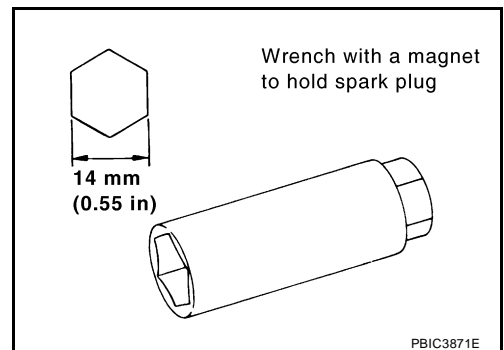

INSPECTION AFTER REMOVAL

CAUTION:

- Never drop or shock spark plug.

ENGINE MAINTENANCE

- Checking and adjusting spark plug gap is not required between change intervals.

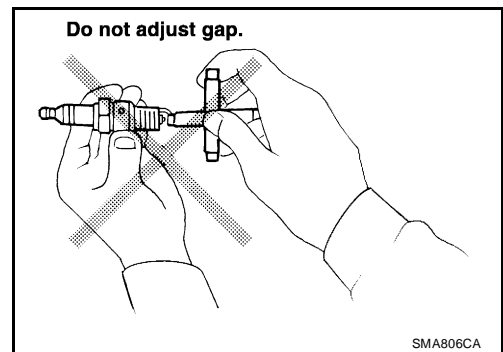

- If spark plug tip is covered with carbon, a spark plug cleaner may be used.

Cleaner air pressure : Less than 588 kPa (5.88 bar, 6 kg/cm² , 85 psi)

Cleaning time : Less than 20 seconds

- Never use wire brush for cleaning spark plug.

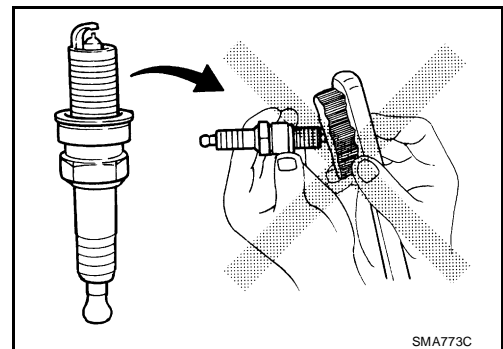

INSTALLATION

1. Install spark plug using suitable tool.

Plug type : Iridium tipped

Make : DENSO

Part number : FXE20HR11

Gap (nominal) : 1.1 mm (0.043 in)

CAUTION:

Never drop or shock spark plug.

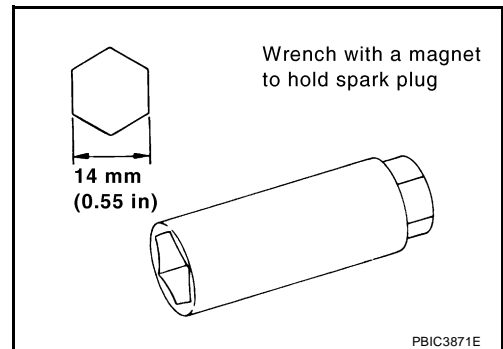

2. Install ignition coil.

CAUTION:

- Handle ignition coil carefully and avoid impacts.

- Never disassemble ignition coil.

3. Install intake manifold. Refer to [EM-18, "INTAKE MANIFOLD"](#) .

Checking EVAP Vapor Lines

ELS0020P

1. Visually inspect EVAP vapor lines for improper attachment and for cracks, damage, loose connections, chafing and deterioration.
2. Inspect fuel tank filler cap vacuum relief valve for clogging, sticking, etc.
Refer to [MA-19, "Checking EVAP Vapor Lines"](#)

CHASSIS AND BODY MAINTENANCE

PFP:00100

Changing In-cabin Microfilter

ELS0022D

1. Remove the glove box assembly. Refer to [IP-10, "INSTRUMENT PANEL ASSEMBLY"](#).
2. Compress the air conditioner filter (1) downward while sliding it to the RH side of the vehicle to release the upper pawl.
3. Move the bottom of air conditioner filter (1) upward as shown to release the bottom tab, then remove it.
4. Replace the air conditioner filter with new one and install the new filter in the A/C unit assembly.

CAUTION:

Make sure that the air conditioner filter lower tab is fully seated, and that the air conditioner upper pawl is locked into place securing the new filter into the A/C unit assembly.

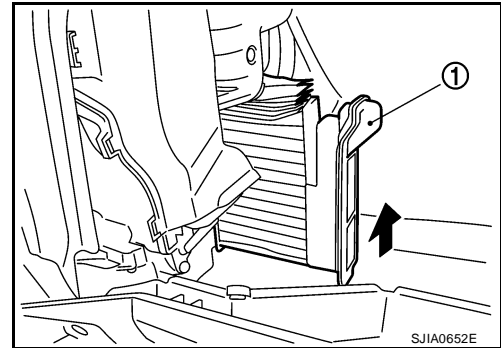

Checking Exhaust System

ELS0021U

Check the exhaust pipes, muffler, and exhaust mounts for improper attachment, leaks, cracks, damage, chafing, or deterioration.

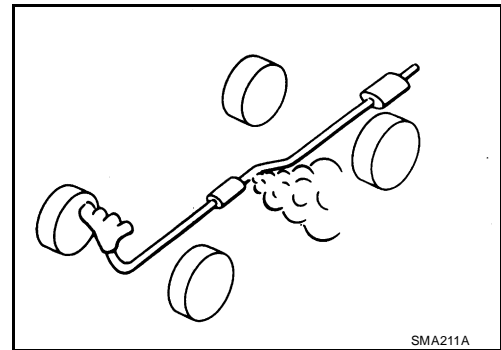

Checking CVT Fluid FLUID LEVEL CHECK

ELS0021V

Fluid level should be checked with the fluid warmed up to 50 to 80°C (122 to 176°F).

1. Check for fluid leakage.
2. With the engine warmed up, drive the vehicle to warm up the CVT fluid. When ambient temperature is 20°C (68°F), it takes about 10 minutes for the CVT fluid to warm up to 50 to 80°C (122 to 176°F).
3. Park the vehicle on a level surface and set the parking brake.
4. With engine at idle, while depressing brake pedal, move the selector lever throughout the entire shift range and return it to the "P" position.

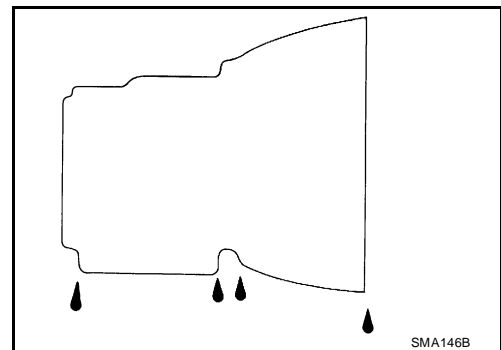

5. Press the tab on the CVT fluid level gauge to release the lock and pull out the CVT fluid level gauge from the CVT fluid charging pipe.

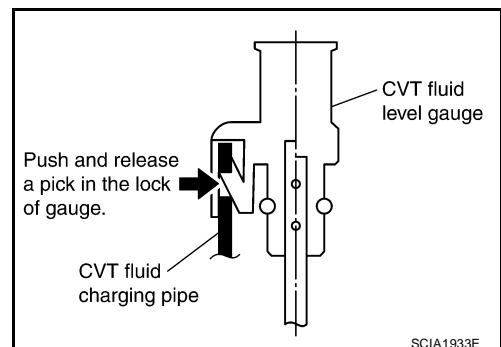

CHASSIS AND BODY MAINTENANCE

6. Wipe fluid off the CVT fluid level gauge. Then rotate the CVT fluid level gauge 180° and re-insert it into the CVT charging pipe as far as it will go.

CAUTION:

Always use lint free paper towels to wipe fluid off the CVT fluid level gauge.

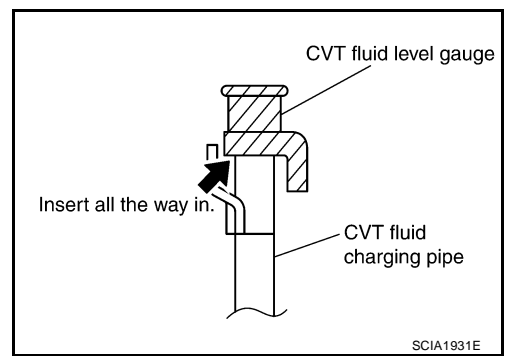

7. Remove the CVT fluid level gauge and check that the fluid level is within the specified range as shown. If the fluid level is at or below the low side of the range, add the necessary specified NISSAN CVT fluid through the CVT charging pipe.

Fluid grade: Refer to [MA-11, "Fluids and Lubricants"](#) .

CAUTION:

- Only use specified NISSAN CVT fluid.
- Do not overfill the CVT.

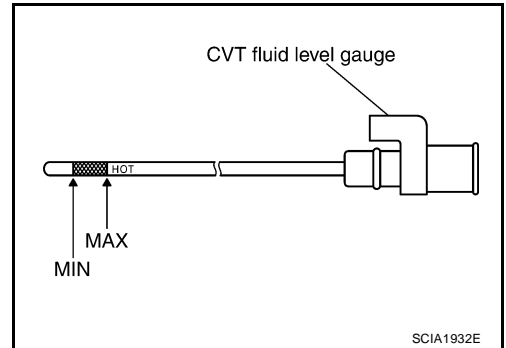

8. Install the CVT fluid level gauge to the CVT fluid charging pipe until it locks.

CAUTION:

When CVT fluid level gauge is installed into the CVT fluid charging pipe, make sure that the CVT fluid level gauge is securely locked in place.

FLUID CONDITION CHECK

Fluid status	Conceivable cause	Required operation
Varnished (viscous varnish state)	Clutch, brake scorched	Replace the CVT fluid and check the CVT main unit and the vehicle for malfunctions (wire harness, cooler pipes, etc.)
Milky white or cloudy	Water in the fluid	Replace the CVT fluid and check for places where water is getting in.
Large amount of metal powder mixed in fluid	Unusual wear of sliding parts within CVT	Replace the CVT fluid and check for improper operation of the CVT.

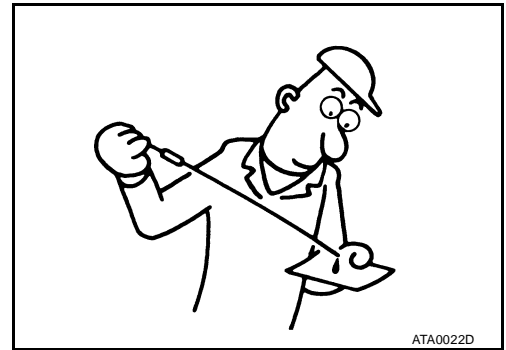

Changing CVT Fluid

1. Warm up CVT fluid by driving the vehicle for 10 minutes.
 - ↙: Vehicle front
 - Radiator (2)
 - CVT fluid cooler hose [inlet side (3)]
 - Transaxle assembly (4)
2. Drain CVT fluid from CVT fluid cooler hose [outlet side (1)] and refill with new specified NISSAN CVT fluid in the CVT fluid charging pipe with the engine running at idle speed.

Fluid capacity and grade: Refer to [MA-11, "Fluids and Lubricants"](#) .

CAUTION:

Only use the specified NISSAN CVT fluid.

3. Refill until new CVT fluid comes out from CVT fluid cooler hose [outlet side (1)].

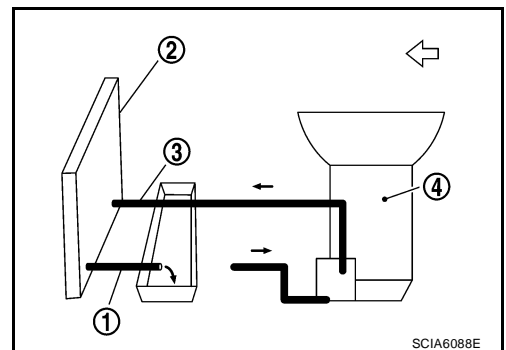

CHASSIS AND BODY MAINTENANCE

NOTE:

About 30 to 50% extra fluid will be required for this procedure.

4. Check fluid level and condition. Refer to [MA-20, "Checking CVT Fluid"](#) .

CAUTION:

Delete CVT fluid deterioration date with CONSULT-II after changing CVT fluid. Refer to [CVT-60, "Check CVT Fluid Deterioration Date"](#) .

Checking Clutch Fluid Level and Leaks

ELS001X6

If fluid level is extremely low, check clutch system for leaks.

Checking Clutch System

ELS001X7

Check fluid lines and operating cylinder for improper attachment, cracks, damage, loose connections, chafing and deterioration.

Checking M/T Oil

ELS0021X

OIL LEAKAGE AND OIL LEVEL

1. Make sure that oil is not leaking from transaxle or around it.
2. Remove filler plug (1) and check oil level at filler plug hole as shown.

CAUTION:

Do not start engine while checking oil level

3. Install a new gasket onto filler plug (1) and install it into transaxle. Tighten filler plug to specification. Refer to [MT-17, "Case and Housing Components"](#) .

CAUTION:

Do not reuse gasket.

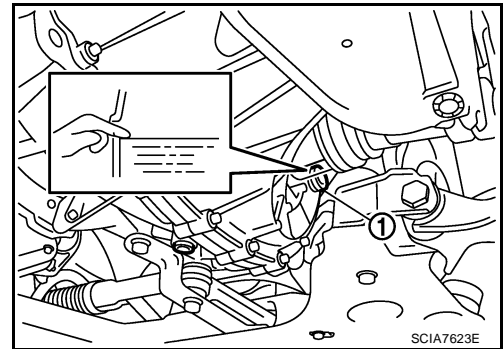

Changing M/T Oil DRAINING

ELS0021Y

1. Start engine and let it run to warm up transaxle.
2. Stop engine. Remove drain plug (1) and drain oil.
3. Install a new gasket onto drain plug (1) and install it into transaxle. Tighten drain plug to specification. Refer to [MT-17, "Case and Housing Components"](#) .

CAUTION:

Do not reuse gasket.

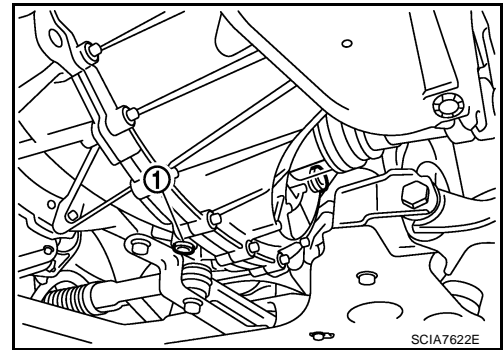

FILLING

1. Remove filler plug (1). Fill with new oil until oil level reaches the specified limit at filler plug hole as shown.

Oil grade and capacity

: Refer to [MA-11, "Fluids and Lubricants"](#)

2. After refilling oil, check oil level. Install a new gasket on filler plug (1), then install it into transaxle. Tighten filler plug to specification. Refer to [MT-17, "Case and Housing Components"](#) .

CAUTION:

Do not reuse gasket.

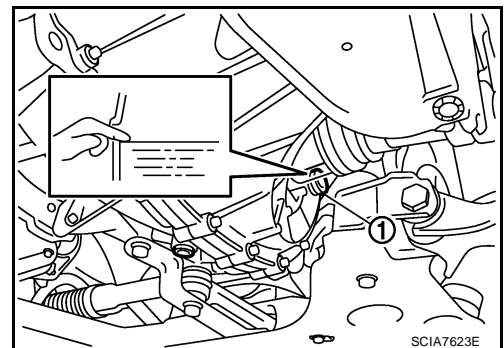

Checking A/T Fluid

ELS0021Z

1. Warm up engine.

CHASSIS AND BODY MAINTENANCE

2. Check for A/T fluid leakage.
3. Before driving, A/T fluid level can be checked at A/T fluid temperatures of 30 to 50°C (86 to 122°F) using the “COLD” range on A/T fluid level gauge.
 - a. Park vehicle on level surface and set parking brake.
 - b. Start engine and move selector lever through each gear position. Leave selector lever in “P” position.
 - c. Check A/T fluid level with engine idling.

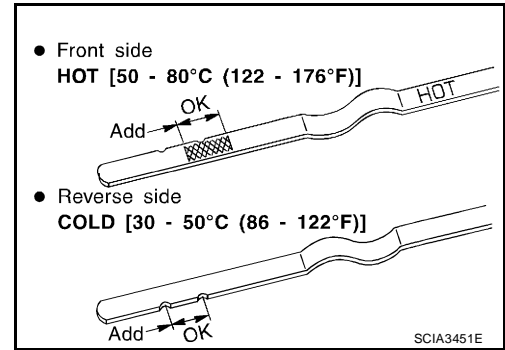

- d. Remove A/T fluid level gauge and wipe clean with lint-free cloth.
CAUTION:
When wiping the A/T fluid level gauge, always use lint-free cloth.
- e. Re-insert A/T fluid level gauge into A/T fluid charging pipe as far as it will go.

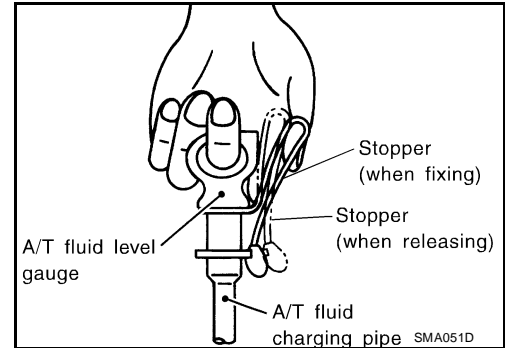

- f. Remove A/T fluid level gauge and note reading. If reading is at low side of range, add A/T fluid to the A/T fluid charging pipe.

CAUTION:

Do not overfill.

4. Drive vehicle for approximately 5 minutes.
5. Re-check A/T fluid level at A/T fluid temperatures of 50 to 80°C (122 to 176°F) using “HOT” range on A/T fluid level gauge.

CAUTION:

● When wiping the A/T fluid level gauge, always use lint-free cloth.

● Firmly fix the A/T fluid level gauge to the A/T fluid charging pipe using the stopper attached.

6. Check A/T fluid condition and make any necessary repairs. Refer to [AT-53, "Fluid Condition Check"](#) . If the A/T fluid contains frictional material (clutches, bands, etc.), or if the A/T is repaired, overhauled, or replaced, inspect and clean the A/T fluid cooler mounted in the radiator. Refer to [AT-17, "A/T Fluid Cooler Cleaning"](#) .
7. Install the removed A/T fluid level gauge into the A/T fluid charging pipe.

CAUTION:

Firmly fix the A/T fluid level gauge to the A/T fluid charging pipe using the stopper attached.

Changing A/T Fluid

ELS00220

1. Warm up A/T fluid.
2. Stop engine.
3. Drain A/T fluid by removing the drain plug. Reinstall the drain plug to the specified torque.

CAUTION:

Do not reuse drain plug gasket.

Drain plug: Refer to [AT-251, "Components"](#) .

4. Refill the transaxle with new specified A/T fluid through the A/T fluid charging pipe. Always refill the transaxle with the same volume of A/T fluid that was drained out.

Fluid grade and capacity: Refer to [MA-11, "RECOMMENDED FLUIDS AND LUBRICANTS"](#) .

5. Run engine at idle speed for 5 minutes.
6. Check A/T fluid level and condition. Refer to [MA-22, "Checking A/T Fluid"](#) .

CHASSIS AND BODY MAINTENANCE

ELS0022E

Balancing Wheels

Adjust wheel balance using road wheel center.

CAUTION:

- Be careful not to scratch the road wheel during removal.
- Use clip-on type wheel balance weights only.

Wheel balance (Maximum allowable unbalance):

Maximum allowable unbalance	Dynamic (At rim flange)	Less than 5 g (0.18 oz) (one side)
	Static (At rim flange)	Less than 10 g (0.35 oz)

Rotation

ELS0022F

- Follow the maintenance schedule for tire rotation service intervals. Refer to [MA-7, "PERIODIC MAINTENANCE"](#).
- Do not include the T-type spare tire when rotating tires.

CAUTION:

- When installing wheels, tighten them diagonally by dividing the work two to three times in order to prevent the wheels from developing any distortion.
- Be careful not to tighten wheel nut at torque exceeding the specification to prevent damage of disc rotor.

Wheel nut : 113 N·m (12 kg·m, 83 ft-lb)

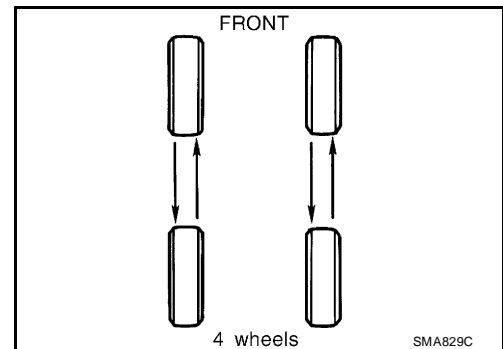

Checking Brake Fluid Level and Leaks

ELS0022G

- If fluid level is extremely low, check brake system for leaks.

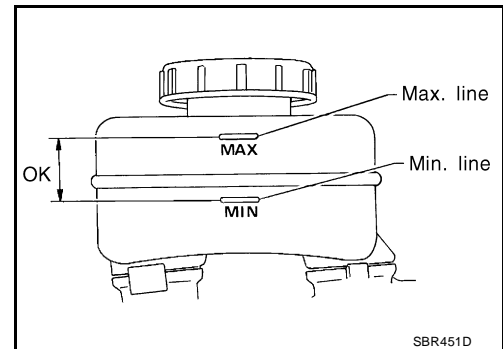

Checking Brake Lines and Cables

ELS0022H

- Check brake fluid lines and parking brake cables for improper attachment, leaks, chafing, abrasions, deterioration, etc.

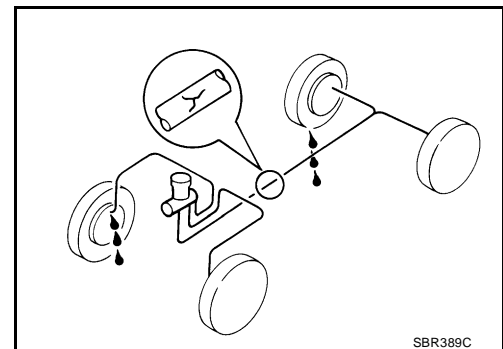

CHASSIS AND BODY MAINTENANCE

Changing Brake Fluid

ELS0022I

1. Drain brake fluid from each bleed valve.
2. Refill until new brake fluid comes out from each bleed valve. Use same procedure as in bleeding hydraulic system to refill brake fluid.
Refer to [BR-10, "Bleeding Brake System"](#) .
 - Refill with recommended Genuine Brake Fluid or equivalent DOT 3 (US FMVSS No. 116).
Refer to [MA-11, "RECOMMENDED FLUIDS AND LUBRICANTS"](#) .
 - Never reuse drained brake fluid.
 - Be careful not to splash brake fluid on painted areas.

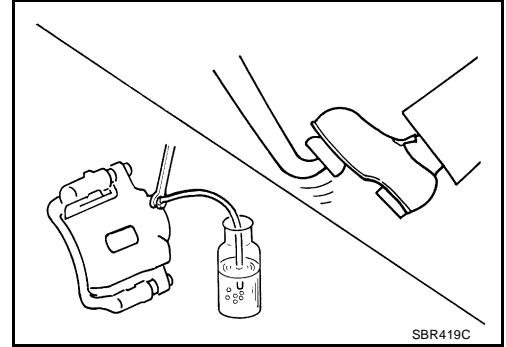

Checking Disc Brake ROTOR

ELS0022J

Check the rotor condition and thickness. Resurface or replace the rotor as necessary.

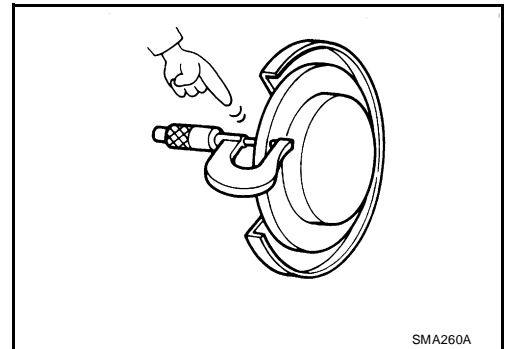

CALIPER

Check the caliper for leakage.

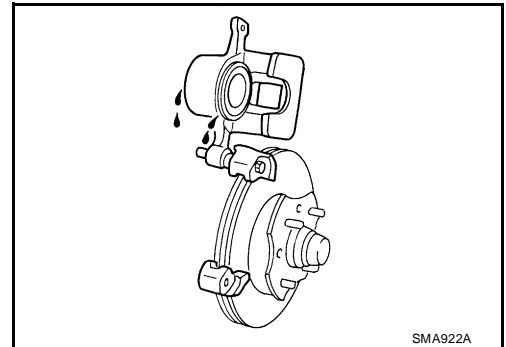

PAD

Check the brake pads for wear or damage. Refer to [BR-34, "Disassembly and Assembly of Wheel Cylinder"](#) .

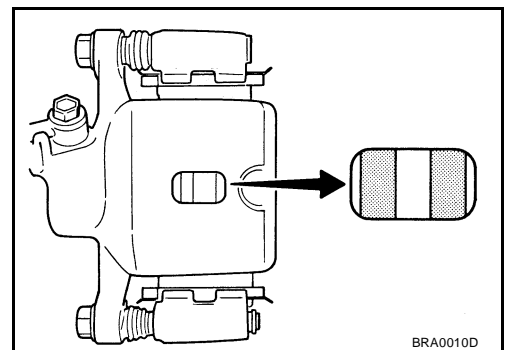

A
B
C
D
E
F
G
H
I
J
K
MA
M

CHASSIS AND BODY MAINTENANCE

WHEEL CYLINDER

Check for leakage.

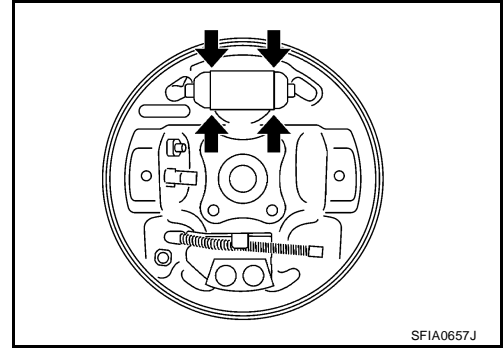

LINING

Check for lining thickness (A). Refer to [BR-34, "Disassembly and Assembly of Wheel Cylinder"](#) .

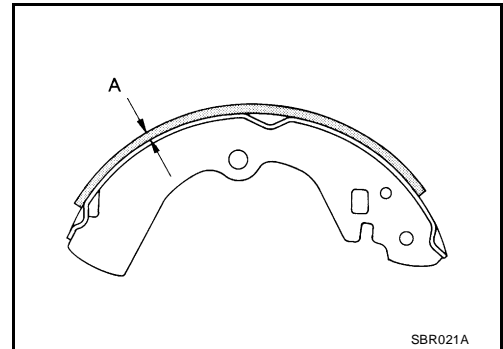

Axle and Suspension Parts

Check front and rear axle and suspension parts for excessive play, cracks, wear or other damage.

- Shake each wheel to check for excessive play.
- Check wheel bearings for smooth operation.
- Check axle and suspension nuts and bolts for looseness.
- Check strut (shock absorber) for oil leakage or other damage.
- Check suspension ball joint for grease leakage and ball joint dust cover for cracks or other damage.

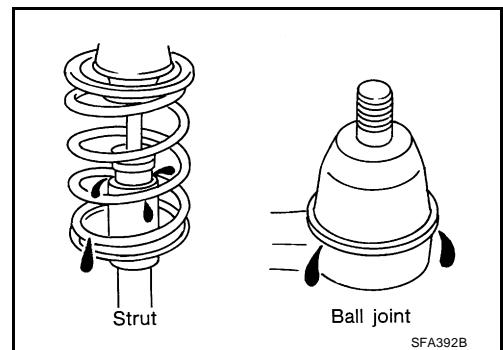
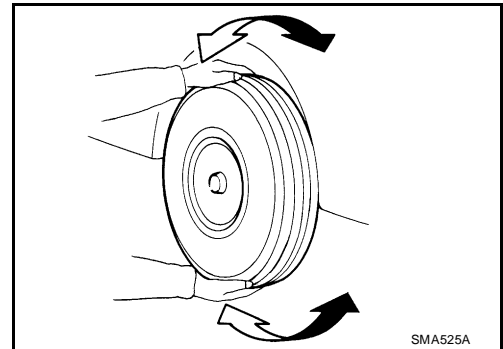

CHASSIS AND BODY MAINTENANCE

Drive Shaft

ELS0022L

Check boot and drive shaft for cracks, wear, damage and grease leakage.

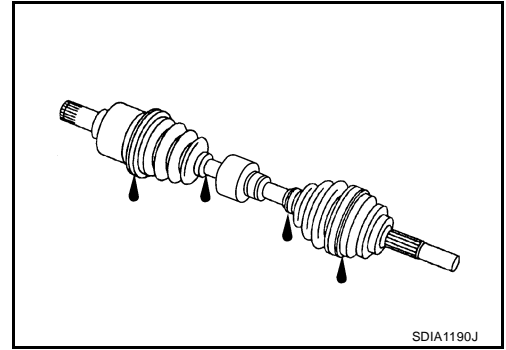

Lubricating Locks, Hinges and Hood Latch

ELS0022M

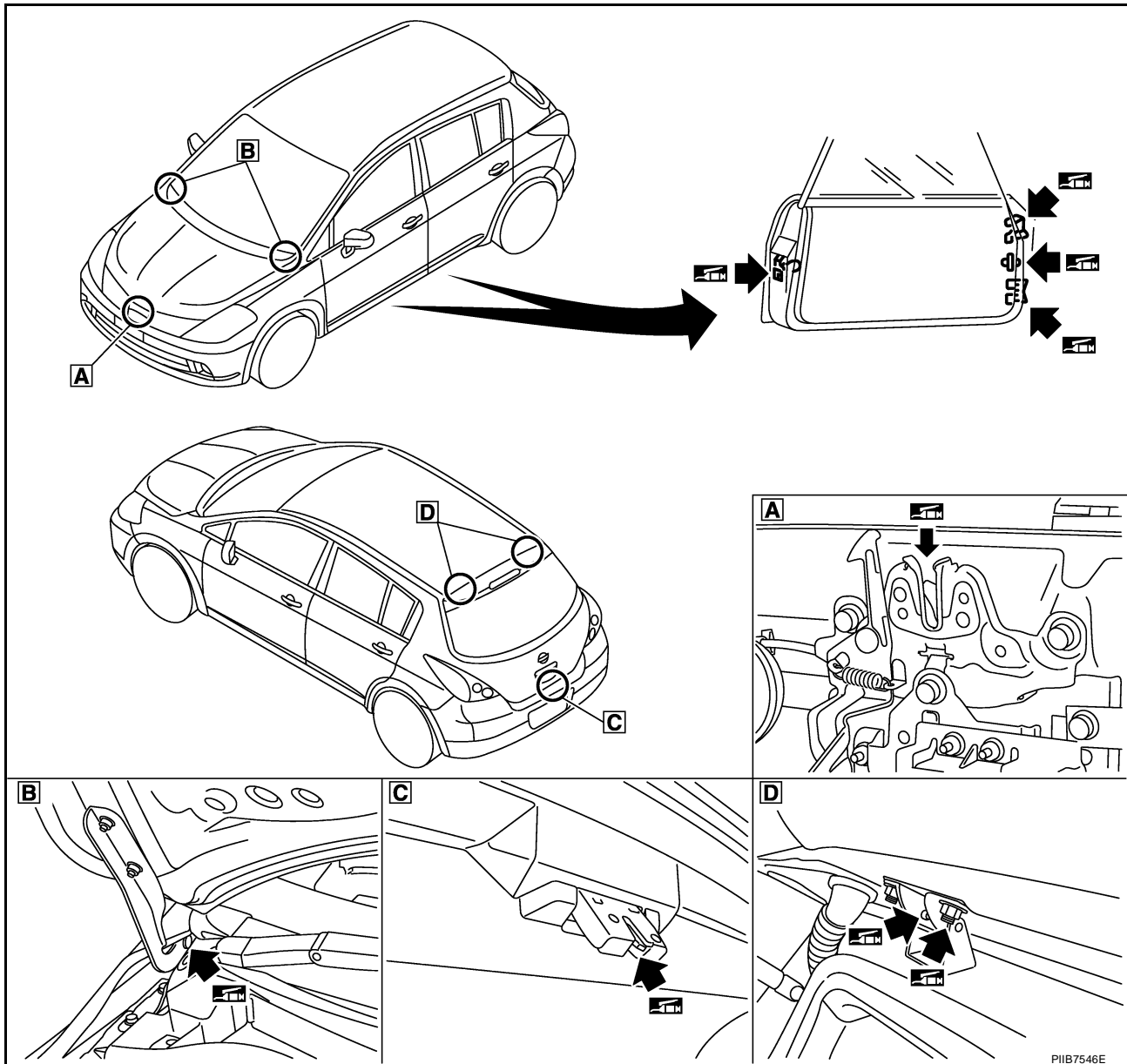

Checking Seat Belts, Buckles, Retractors, Anchors and Adjusters

ELS0022N

Check the seat belt buckles, webbing, retractors, anchors and adjusters. Replace any seat belt assembly as necessary. Refer to [SB-9, "Seat Belt Inspection"](#).

- Check the seat belt anchors for loose bolts, damage, or excessive wear.
- Check the seat belt webbing for any damage, cuts, fraying, or excessive wear.

A
B
C
D
E
F
G
H
I
J
K
MA
M

CHASSIS AND BODY MAINTENANCE

- Check the retractor for smooth operation.
- Check the function of the buckles by inserting the seat belt tongue and checking for proper engagement of the buckle and press the button on the buckle to check for proper release of the seat belt tongue.

CAUTION:

- **After any collision, inspect all seat belt assemblies, including retractors and other attached components, such as the guide rail set. NISSAN recommends replacing all seat belt assemblies in use during a collision, unless they are not damaged and are inspected to confirm they are operating properly after a minor collision.**
Also inspect all seat belt assemblies that are not in use during a collision, and replace any components if damaged or not operating properly. The seat belt pre-tensioner should be replaced even if the seat belts are not in use during a frontal collision where the driver and passenger air bags have been deployed.
- If any component of the seat belt assembly is suspected of being damaged or not operating properly, do not repair the component. Replace the components as an assembly.
- If the seat belt webbing is cut, frayed, or damaged then replace the seat belt assembly.
- Never lubricate the seat belt buckle or tongue.
- When replacing any seat belt assembly always use a Genuine NISSAN seat belt assembly.