

SECTION **SRS**

SUPPLEMENTAL RESTRAINT SYSTEM (SRS)

A
B
C
D
E
F
G
H
I
J
K
L
M

CONTENTS

<p>PRECAUTIONS 3</p> <p> Precautions for Supplemental Restraint System (SRS) “AIR BAG” and “SEAT BELT PRE-TENSIONER” 3</p> <p> Precautions for SRS “AIR BAG” and “SEAT BELT PRE-TENSIONER” Service 3</p> <p> Occupant Classification System Precaution 3</p> <p>SUPPLEMENTAL RESTRAINT SYSTEM (SRS) 4</p> <p> SRS Configuration 4</p> <p> Driver Air Bag Module 5</p> <p> Front Passenger Air Bag Module 5</p> <p> Front Side Air Bag 5</p> <p> Side Curtain Air Bag 5</p> <p> Front Seat Belt Pre-tensioner with Load Limiter 6</p> <p> Occupant Classification System (OCS) 6</p> <p> Direct-connect SRS Component Connectors 8</p> <p>TROUBLE DIAGNOSIS 9</p> <p> Trouble Diagnosis Introduction 9</p> <p> DIAGNOSIS FUNCTION 9</p> <p> HOW TO PERFORM TROUBLE DIAGNOSES FOR QUICK AND ACCURATE REPAIR 9</p> <p> WORK FLOW 10</p> <p> SRS Components Parts Location 11</p> <p> Schematic 12</p> <p> Wiring Diagram — SRS — 13</p> <p> CONSULT-II Function (AIR BAG) 19</p> <p> HOW TO CHANGE BETWEEN SELF-DIAGNOSIS MODE AND USER MODE WITH CONSULT-II 19</p> <p> HOW TO ERASE SELF-DIAGNOSIS RESULTS.. 20</p> <p> Self-Diagnosis Function (Without CONSULT-II) 20</p> <p> HOW TO CHANGE BETWEEN USER MODE AND SELF-DIAGNOSIS MODE WITHOUT CONSULT-II 21</p> <p> HOW TO ERASE SELF-DIAGNOSIS RESULTS.. 21</p> <p> SRS Operation Check 21</p> <p> DIAGNOSTIC PROCEDURE 1 21</p> <p> Trouble Diagnosis With CONSULT-II 23</p> <p> DIAGNOSTIC PROCEDURE 2 23</p>	<p> DIAGNOSTIC PROCEDURE 3 27</p> <p> DIAGNOSTIC PROCEDURE 4 29</p> <p> DIAGNOSTIC PROCEDURE 5 29</p> <p> Trouble Diagnosis Without CONSULT-II 34</p> <p> DIAGNOSTIC PROCEDURE 6 34</p> <p> WARNING LAMP FLASH CODE CHART 35</p> <p> Trouble Diagnosis: “AIR BAG” Warning Lamp Does Not Turn Off 39</p> <p> DIAGNOSTIC PROCEDURE 7 39</p> <p> Trouble Diagnosis: “AIR BAG” Warning Lamp Does Not Turn On 40</p> <p> DIAGNOSTIC PROCEDURE 8 40</p> <p>DRIVER AIR BAG MODULE 41</p> <p> Removal and Installation 41</p> <p> REMOVAL 41</p> <p> INSTALLATION 42</p> <p>SPIRAL CABLE 44</p> <p> Removal and Installation 44</p> <p> REMOVAL 44</p> <p> INSTALLATION 45</p> <p>FRONT PASSENGER AIR BAG MODULE 46</p> <p> Removal and Installation 46</p> <p> REMOVAL 46</p> <p> INSALLATION 46</p> <p>SIDE CURTAIN AIR BAG MODULE 47</p> <p> Components 47</p> <p> Removal and Installation 48</p> <p> REMOVAL 48</p> <p> INSTALLATION 48</p> <p>CRASH ZONE SENSOR 49</p> <p> Removal and Installation 49</p> <p> REMOVAL 49</p> <p> INSTALLATION 49</p> <p>SIDE AIR BAG (SATELLITE) SENSOR 50</p> <p> Removal and Installation 50</p> <p> REMOVAL 50</p> <p> INSTALLATION 50</p> <p>FRONT SEAT BELT PRE-TENSIONER 51</p> <p> Removal and Installation 51</p>
--	---

SRS

DIAGNOSIS SENSOR UNIT	52	SRS INSPECTION (FOR FRONTAL COLLISION)	54
Removal and Installation	52	For Side and Rollover Collision	55
REMOVAL	52	WHEN SRS IS ACTIVATED IN THE SIDE OR	
INSTALLATION	52	ROLLOVER COLLISION	55
ECU DISCRIMINATED NO.	52	WHEN SRS IS NOT ACTIVATED IN THE SIDE	
OCCUPANT CLASSIFICATION SYSTEM CONTROL UNIT	53	OR ROLLOVER COLLISION	55
Removal and Installation	53	SRS INSPECTION (FOR SIDE AND ROLLOVER	
COLLISION DIAGNOSIS	54	COLLISION)	56
For Frontal Collision	54		

PRECAUTIONS

PRECAUTIONS

PFP:00001

Precautions for Supplemental Restraint System (SRS) “AIR BAG” and “SEAT BELT PRE-TENSIONER”

EHS001XL

The Supplemental Restraint System such as “AIR BAG” and “SEAT BELT PRE-TENSIONER”, used along with a front seat belt, helps to reduce the risk or severity of injury to the driver and front passenger for certain types of collision. This system includes seat belt switch inputs and dual stage front air bag modules. The SRS system uses the seat belt switches to determine the front air bag deployment, and may only deploy one front air bag, depending on the severity of a collision and whether the front occupants are belted or unbelted. Information necessary to service the system safely is included in the SRS and SB section of this Service Manual.

WARNING:

- To avoid rendering the SRS inoperative, which could increase the risk of personal injury or death in the event of a collision which would result in air bag inflation, all maintenance must be performed by an authorized NISSAN/INFINITI dealer.
- Improper maintenance, including incorrect removal and installation of the SRS, can lead to personal injury caused by unintentional activation of the system. For removal of Spiral Cable and Air Bag Module, see the SRS section.
- Do not use electrical test equipment on any circuit related to the SRS unless instructed to in this Service Manual. SRS wiring harnesses can be identified by yellow and/or orange harnesses or harness connectors.

Precautions for SRS “AIR BAG” and “SEAT BELT PRE-TENSIONER” Service

EHS001XM

- Do not use electrical test equipment to check SRS circuits unless instructed to in this Service Manual.
- Before servicing the SRS, turn ignition switch OFF, disconnect both battery cables and wait at least 3 minutes.
For approximately 3 minutes after the cables are removed, it is still possible for the air bag and seat belt pre-tensioner to deploy. Therefore, do not work on any SRS connectors or wires until at least 3 minutes have passed.
- The air bag diagnosis sensor unit must always be installed with the arrow mark “←” pointing toward the front of the vehicle for proper operation. Also check air bag diagnosis sensor unit for cracks, deformities or rust before installation and replace as required.
- The spiral cable must be aligned with the neutral position since its rotations are limited. Do not attempt to turn steering wheel or column after removal of steering gear.
- Handle air bag module carefully. Always place driver and front passenger air bag modules with the pad side facing upward and seat mounted front side air bag module standing with the stud bolt side facing down.
- Conduct self-diagnosis to check entire SRS for proper function after replacing any components.
- After air bag inflates, the front instrument panel assembly should be replaced if damaged.
- Do not reuse center pillar upper garnish if removed.

Occupant Classification System Precaution

EHS001XN

Replace control unit and passenger front seat cushion as an assembly.

A
B
C
D
E
F
G
I
J
K
L
M

SRS

SUPPLEMENTAL RESTRAINT SYSTEM (SRS)

SUPPLEMENTAL RESTRAINT SYSTEM (SRS)

PF2:28556

SRS Configuration

EHS001UR

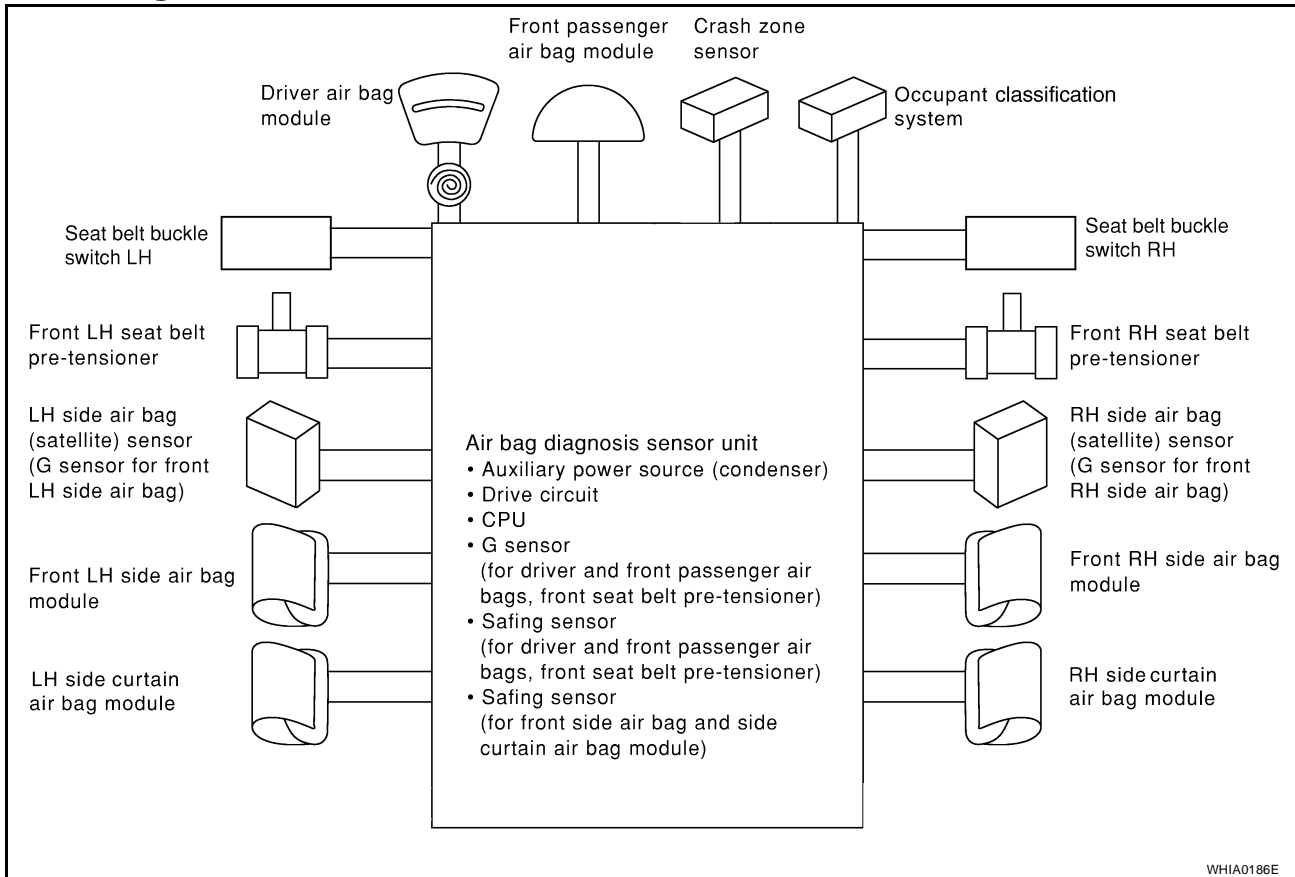

The air bag deploys if the air bag diagnosis sensor unit is activated while the ignition switch is in the ON or START position.

The collision modes for which supplemental restraint systems are activated are different among the SRS systems. For example, the driver air bag module, front passenger air bag module and front seat belt pre-tensioners are activated in a frontal collision but not in a side collision.

SRS configurations for some collision modes are as follows:

SRS configuration	Frontal collision	Left side collision	Right side collision
Driver air bag module	×	—	—
Front passenger air bag module	×	—	—
Front LH seat belt pre-tensioner	×	—	—
Front RH seat belt pre-tensioner	×	—	—
Front LH side air bag module	—	×	—
Front RH side air bag module	—	—	×
LH side curtain air bag module	—	×	—
RH side curtain air bag module	—	—	×

SUPPLEMENTAL RESTRAINT SYSTEM (SRS)

Driver Air Bag Module

EHS001VD

The driver air bag module is dual stage and located in the steering wheel assembly. It operates with the SRS system in a frontal collision exceeding a specified level.

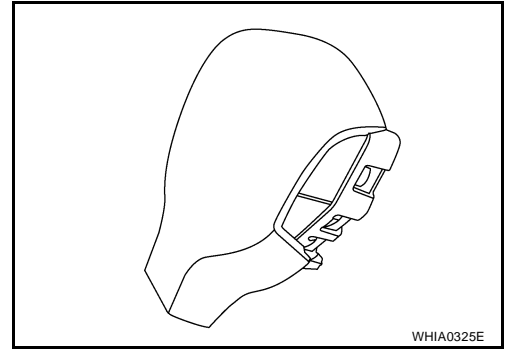

A
B
C
D

Front Passenger Air Bag Module

EHS001VE

The front passenger air bag module is located behind the instrument panel assembly (mounted to the steering member). It operates with the SRS system in a frontal collision exceeding a specified level. Refer to [SRS-6, "Occupant Classification System \(OCS\)"](#) for more information.

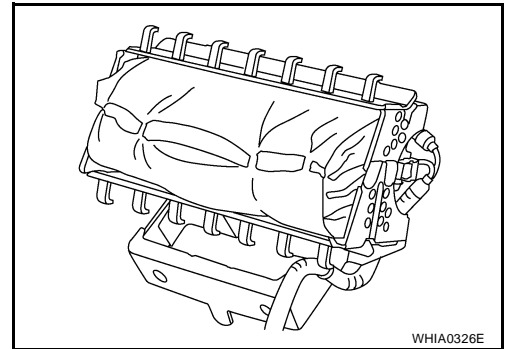

E
F
G

SRS

Front Side Air Bag

EHS001UT

Front side air bag modules are built into the front seatback assemblies. Vehicles with side air bags are equipped with labels as shown.

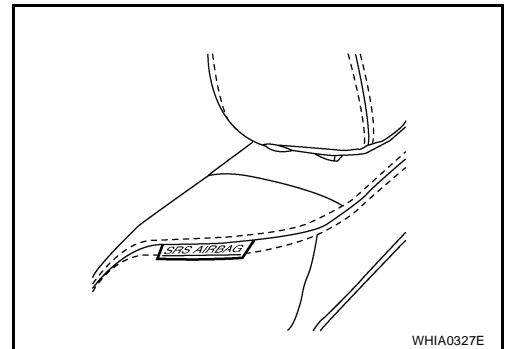

I
J
K
L

Side Curtain Air Bag

EHS001UU

Side curtain air bag modules are located above the vehicle headlining and run from the front to the rear of the vehicle. Vehicles with side curtain air bags are equipped with labels as shown.



M

SUPPLEMENTAL RESTRAINT SYSTEM (SRS)

Front Seat Belt Pre-tensioner with Load Limiter

EHS001US

The seat belt pre-tensioner system with load limiter is installed for both the driver's seat and the front passenger's seat. It operates simultaneously with the SRS air bag system in the event of a frontal collision with an impact exceeding a specified level.

When the frontal collision with an impact exceeding a specified level occurs, seat belt slack resulting from clothing or other factors is immediately taken up by the pre-tensioner. Vehicle passengers are securely restrained.

When passengers in a vehicle are thrown forward in a collision and the restraining force of the seat belt exceeds a specified level, the load limiter permits the specified extension of the seat belt by the twisting of the ELR shaft, and a relaxation of the chest-area seat belt web tension while maintaining force.

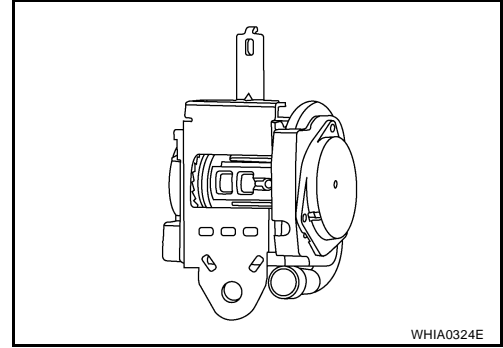

Occupant Classification System (OCS)

EHS001UV

The occupant classification system (OCS) identifies different size occupants, out of position occupants, and detects if child seat is present in the front passenger seat. The OCS receives inputs from the occupant classification system sensor (located under the passenger seat cushion assembly) and belt tension sensor (part of the passenger front seat belt assembly and located at the belt anchor location). Depending on classification of the passenger, the OCS sends a signal to the air bag diagnosis sensor unit. The air bag diagnosis sensor unit uses this signal and the seat belt buckle switch RH signal to determine deployment or non deployment of the front passenger air bag module in the event of a collision. Depending on the signals received, the air bag diagnosis sensor unit can disable the front passenger air bag module completely.

NOTE:

In case of customer concern, CONSULT-II can be used to confirm the passenger air bag status (readiness).

Passenger Air Bag Status Conditions

Front Passenger Seat (Condition)	PASS AIR BAG OFF Indicator (Status)	Passenger Air Bag Status (Readiness)	CONSULT-II Display
Seat occupied	OFF	Active (enabled)	ON
Seat occupied ^{NOTE}	ON	Deactivated (disabled)	OFF
Seat empty	OFF	Deactivated (disabled)	OFF

NOTE:

Passenger does not meet Occupant Classification System specifications for passenger air bag activation.

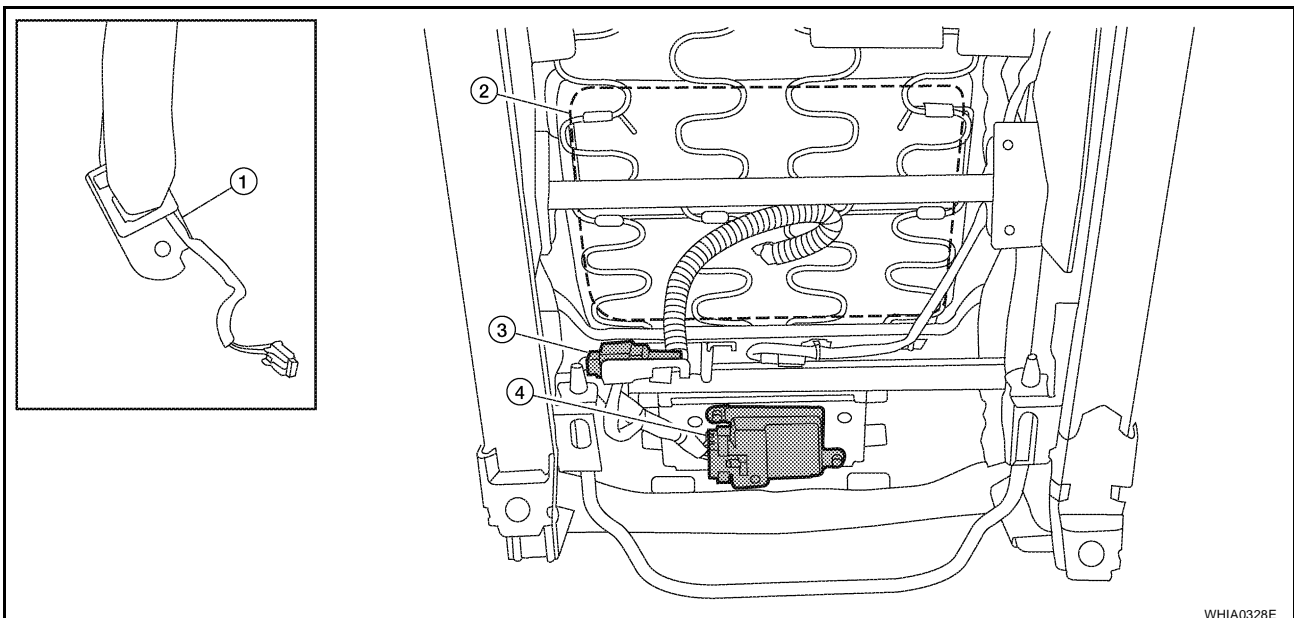

SUPPLEMENTAL RESTRAINT SYSTEM (SRS)

1. Belt tension sensor
2. Occupant classification system bladder
3. Occupant classification system sensor
4. Occupant classification system control unit

A

B

C

D

E

F

G

SRS

I

J

K

L

M

SUPPLEMENTAL RESTRAINT SYSTEM (SRS)

EHS001UW

Direct-connect SRS Component Connectors

The following SRS components use direct-connect style harness connectors.

- Driver air bag module
- Passenger air bag module
- LH side curtain air bag module
- RH side curtain air bag module
- Front LH seat belt pre-tensioner
- Front RH seat belt pre-tensioner

Always pull up to release the locking tab prior to removing connector from SRS component.

Always push down to lock the locking tab after installing connector to SRS component. When locked, the locking tab is level with the connector housing.

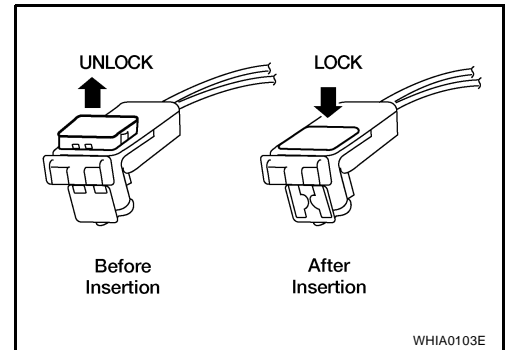

TROUBLE DIAGNOSIS

PFP:00004

TROUBLE DIAGNOSIS

Trouble Diagnosis Introduction

EHS001UX

CAUTION:

- Do not use electrical test equipment on any circuit related to the SRS unless instructed to do so in this Service Manual.
- Do not attempt to repair, splice or modify SRS wiring harnesses. If a harness is damaged, replace it with a new one.
- Keep ground connections clean.

DIAGNOSIS FUNCTION

The SRS self-diagnosis results can be read by using "AIR BAG" warning lamp and/or CONSULT-II. The User mode is exclusively prepared for the customer (driver). This mode warns the driver of a system malfunction through the operation of the "AIR BAG" warning lamp. The Diagnosis mode allows the technician to locate and inspect the malfunctioning part. The mode applications for the "AIR BAG" warning lamp and CONSULT-II are as follows:

	User mode	Diagnosis mode	Display type
"AIR BAG" warning lamp	X	X	ON-OFF operation
CONSULT-II	—	X	Monitoring

HOW TO PERFORM TROUBLE DIAGNOSES FOR QUICK AND ACCURATE REPAIR

A good understanding of the malfunction conditions can make troubleshooting faster and more accurate. In general, each customer feels differently about a malfunction. It is important to fully understand the symptoms or conditions for a customer complaint.

Information From Customer

WHAT - Vehicle model
WHEN - Date, Frequencies
WHERE - Road conditions
HOW - Operating conditions, Symptoms

Preliminary Check

Check that the following parts are in good order.

- Battery (Refer to [SC-4, "How to Handle Battery"](#) .)
- Fuses (Refer to [SRS-12, "Schematic"](#) .)
- System component-to-harness connections

A

B

C

D

E

F

G

SRS

I

J

K

L

M

TROUBLE DIAGNOSIS

WORK FLOW

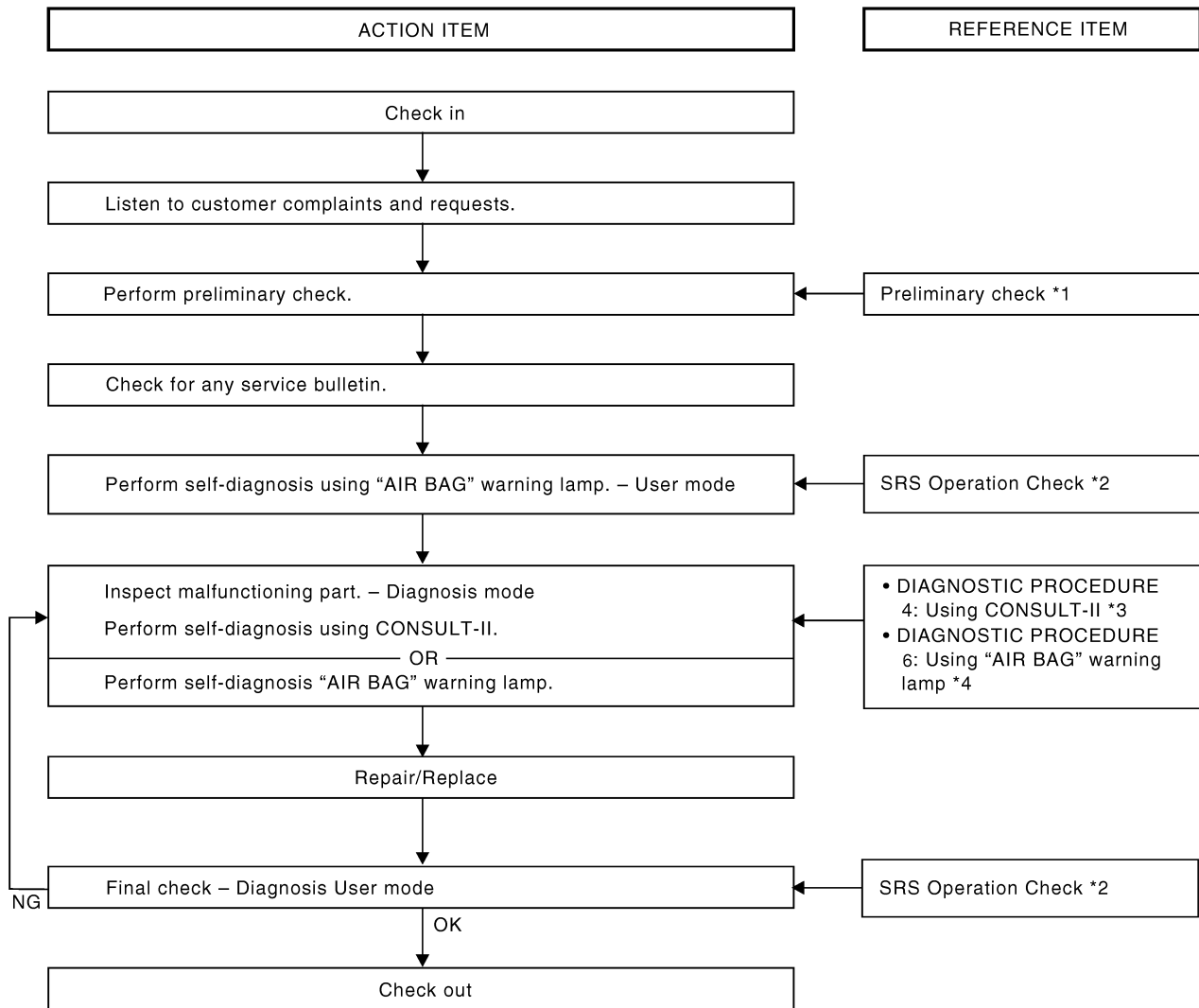

WHIA0098E

*1: [SRS-9](#)

*2: [SRS-21](#)

*3: [SRS-29](#)

*4: [SRS-34](#)

TROUBLE DIAGNOSIS

SRS Components Parts Location

EHS001UY

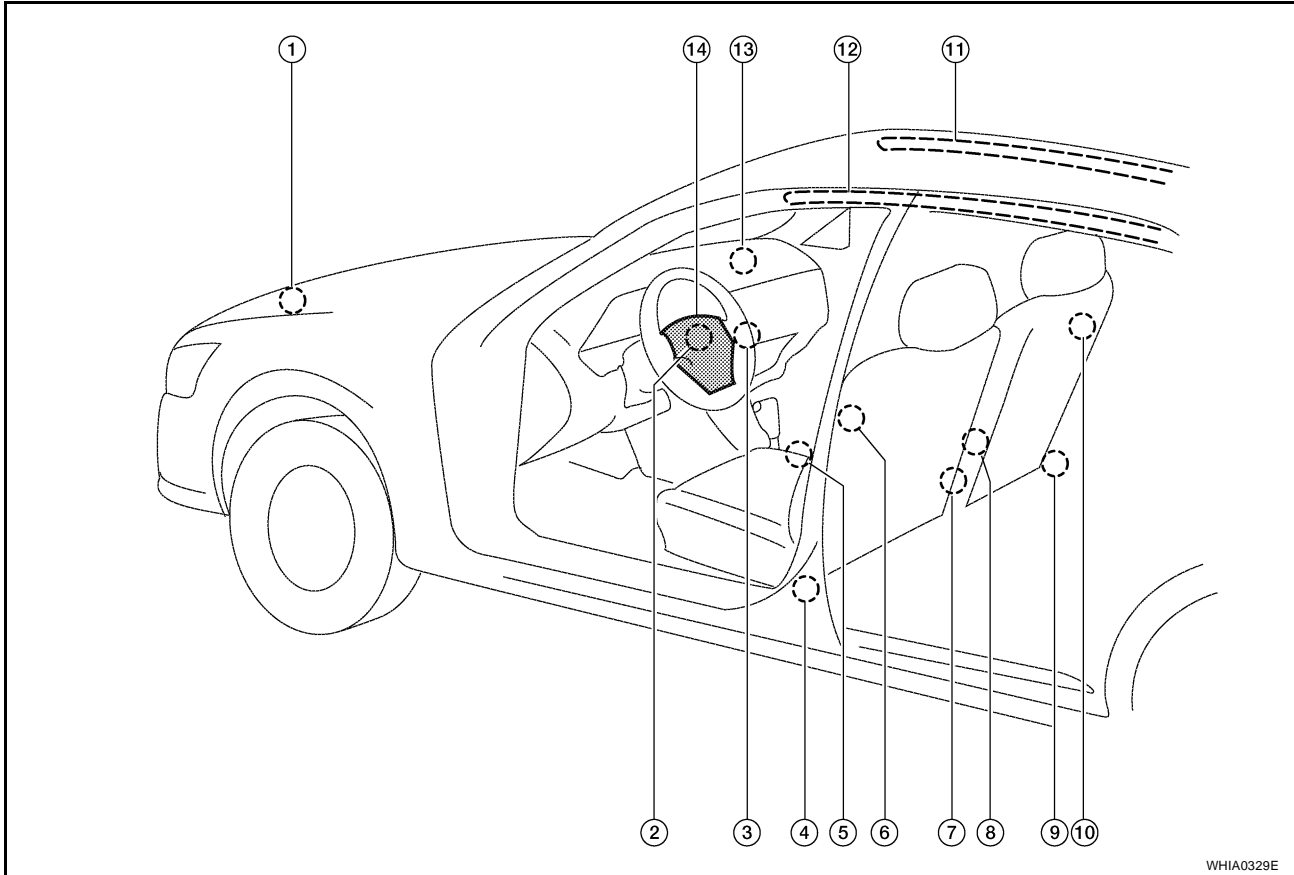

WHIA0329E

- | | | |
|---|---|--|
| 1. Crash zone sensor | 2. Spiral cable | 3. Front passenger air bag off indicator |
| 4. Front LH seat belt pre-tensioner
LH side air bag (satellite) sensor | 5. Air bag diagnosis sensor unit | 6. Front LH side air bag module |
| 7. Seat belt buckle switch (LH)
Seat belt buckle switch (RH) | 8. Occupant classification system control unit
Occupant classification system sensor | 9. Front RH seat belt pre-tensioner
RH side air bag (satellite) sensor
Belt tension sensor |
| 10. Front RH side air bag module | 11. RH side curtain air bag module | 12. LH side curtain air bag module |
| 13. Front passenger air bag module | 14. Driver air bag module | |

TROUBLE DIAGNOSIS

Schematic

EHS001UZ

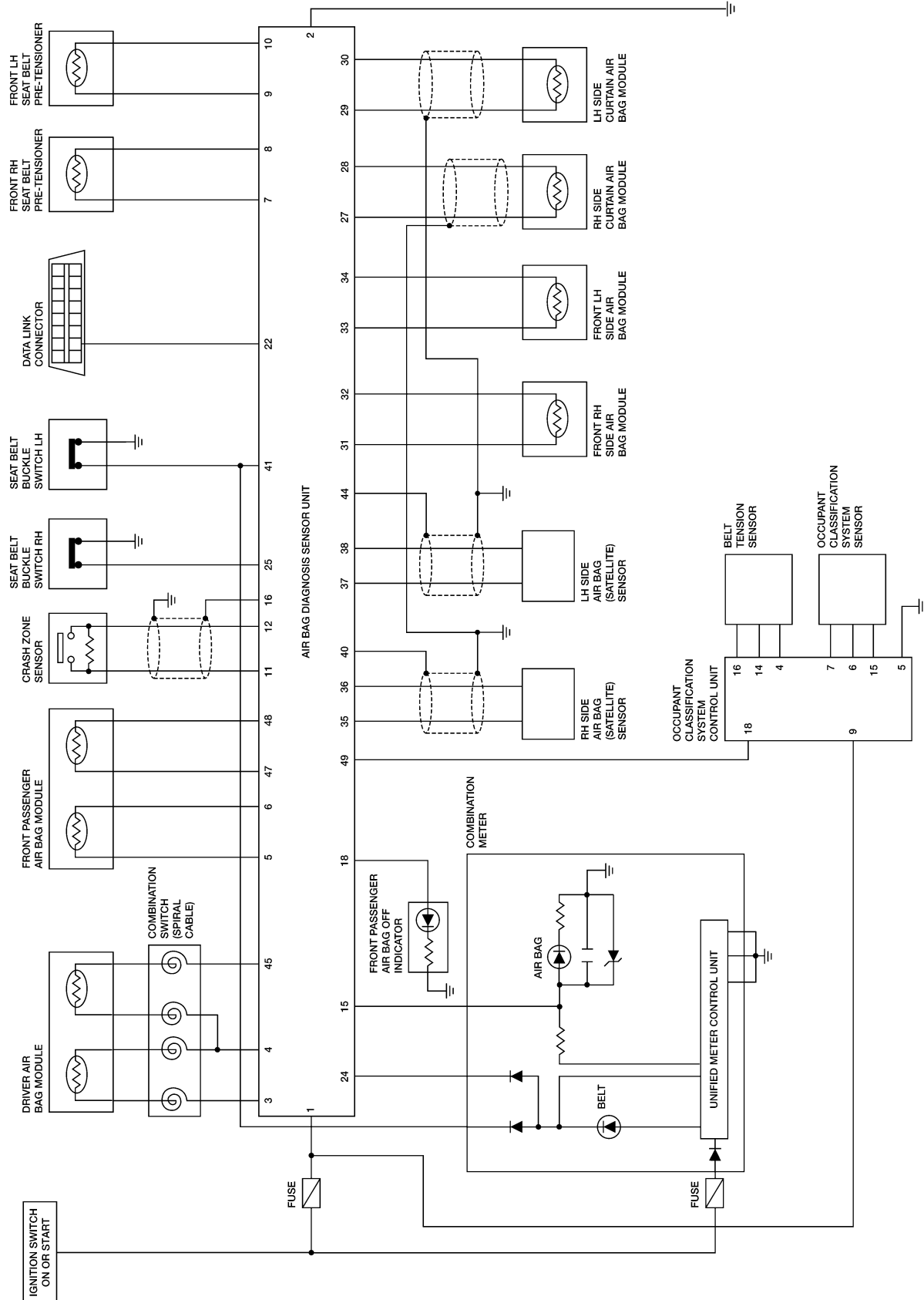

WHWA0296E

TROUBLE DIAGNOSIS

Wiring Diagram — SRS —

EHS001V0

SRS-SRS-01

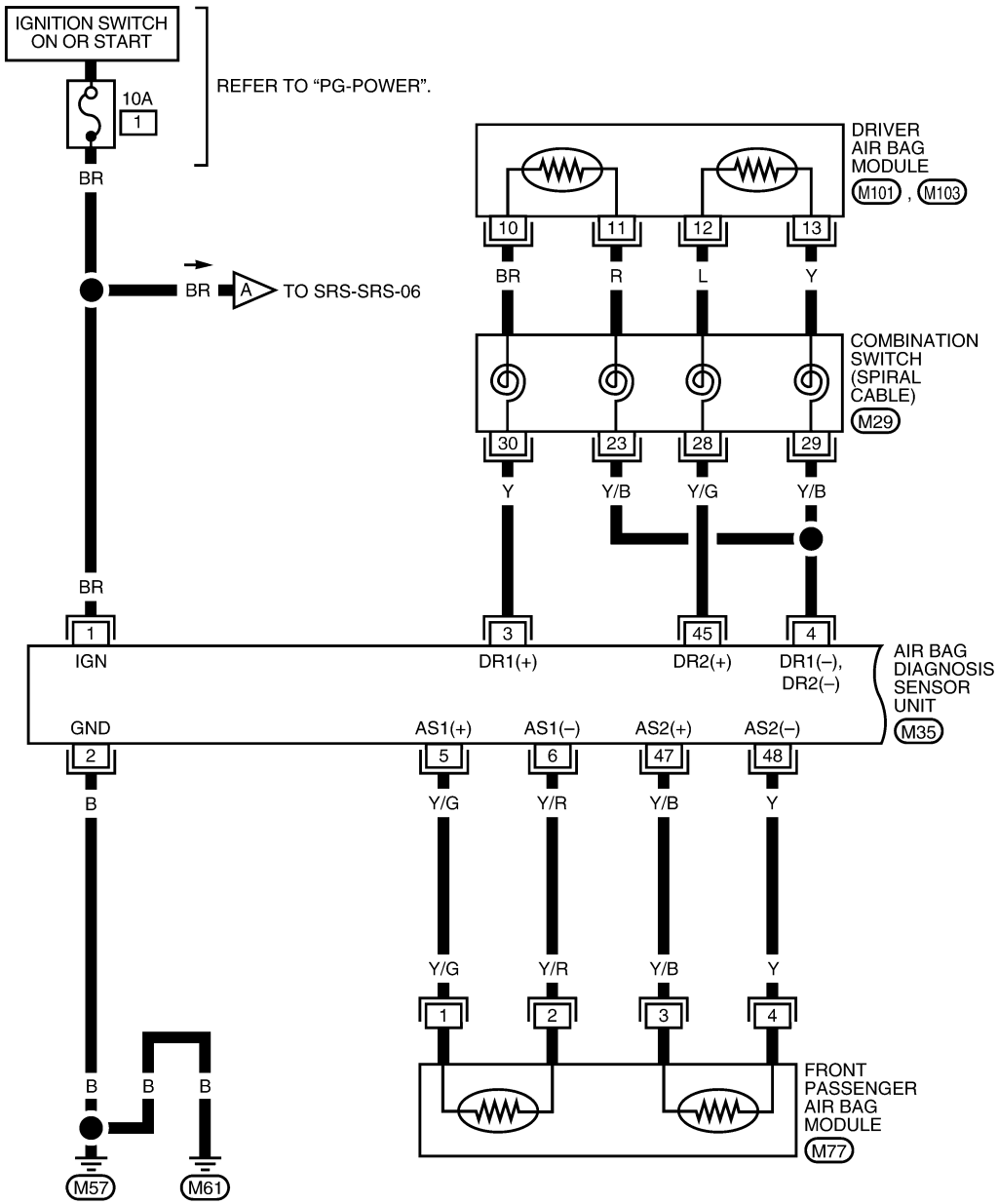

A
B
C
D
E
F
G
SRS
I
J
K
L
M



*: THIS CONNECTOR IS NOT SHOWN IN "HARNESS LAYOUT" OF PG SECTION.

WHWA0297E

TROUBLE DIAGNOSIS

SRS-SRS-02

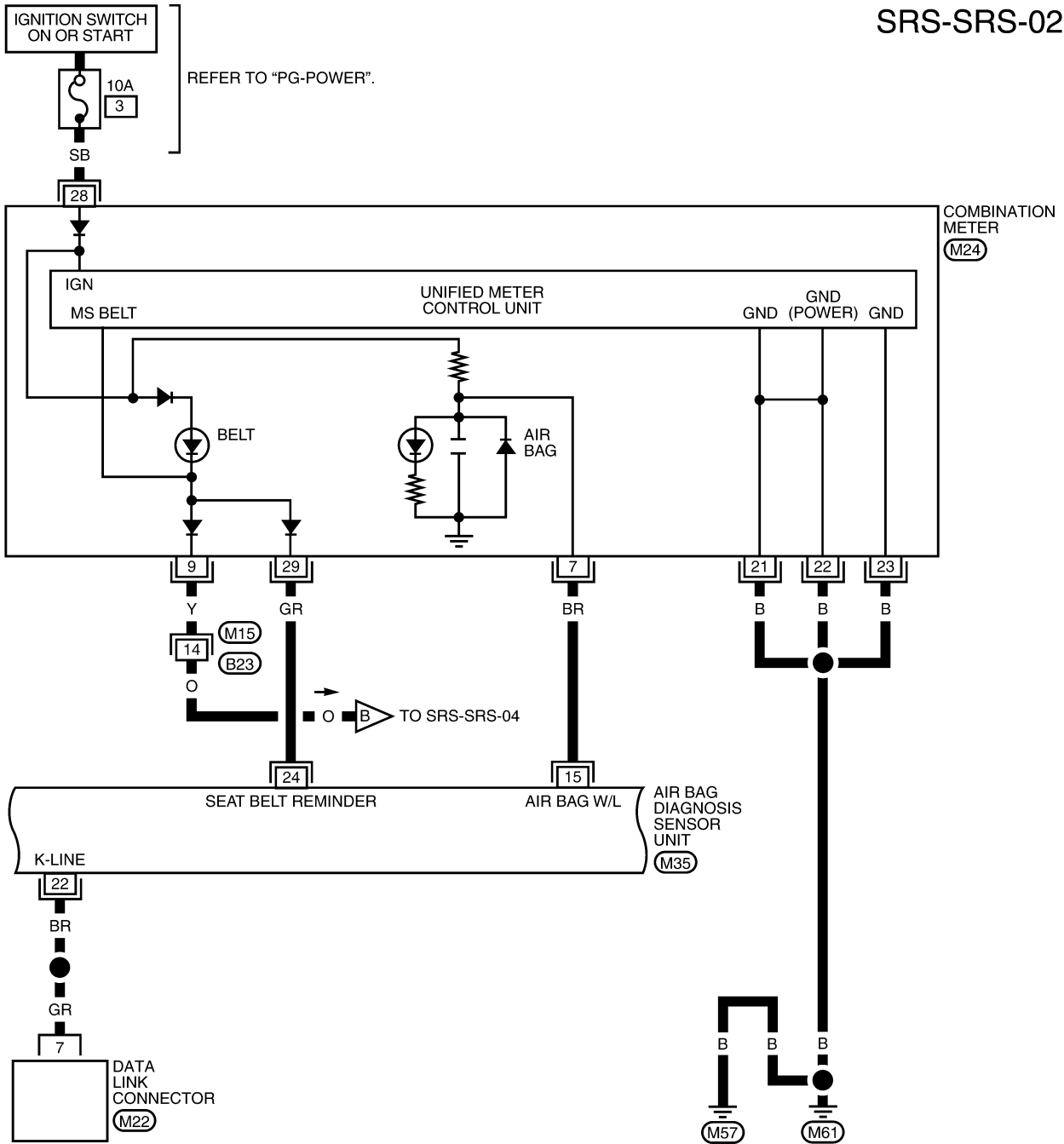

1	2	3	4	5	6	7		
8	9	10	11	12	13	14	15	16

(M15)
W

16	15	14	13	12	11	10	9
8	7	6	5	4	3	2	1

(M22)
W

1	2	3	4	5	6	7	8	9	10	11	12	13	14	15	16	17	18	19	20
21	22	23	24	25	26	27	28	29	30	31	32	33	34	35	36	37	38	39	40

(M24)
W

1	49	24	21						
5	6	4	3	45	47	48	46	11	22
2	18				15	12	16		

(M35)
Y

WHWA0298E

TROUBLE DIAGNOSIS

SRS-SRS-03

A
B
C
D
E
F
G
H
I
J
K
L
M

SRS

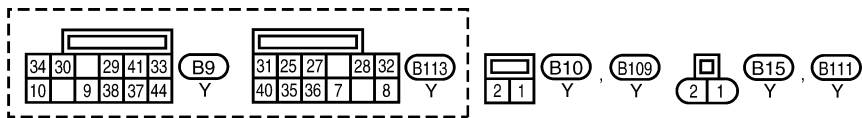
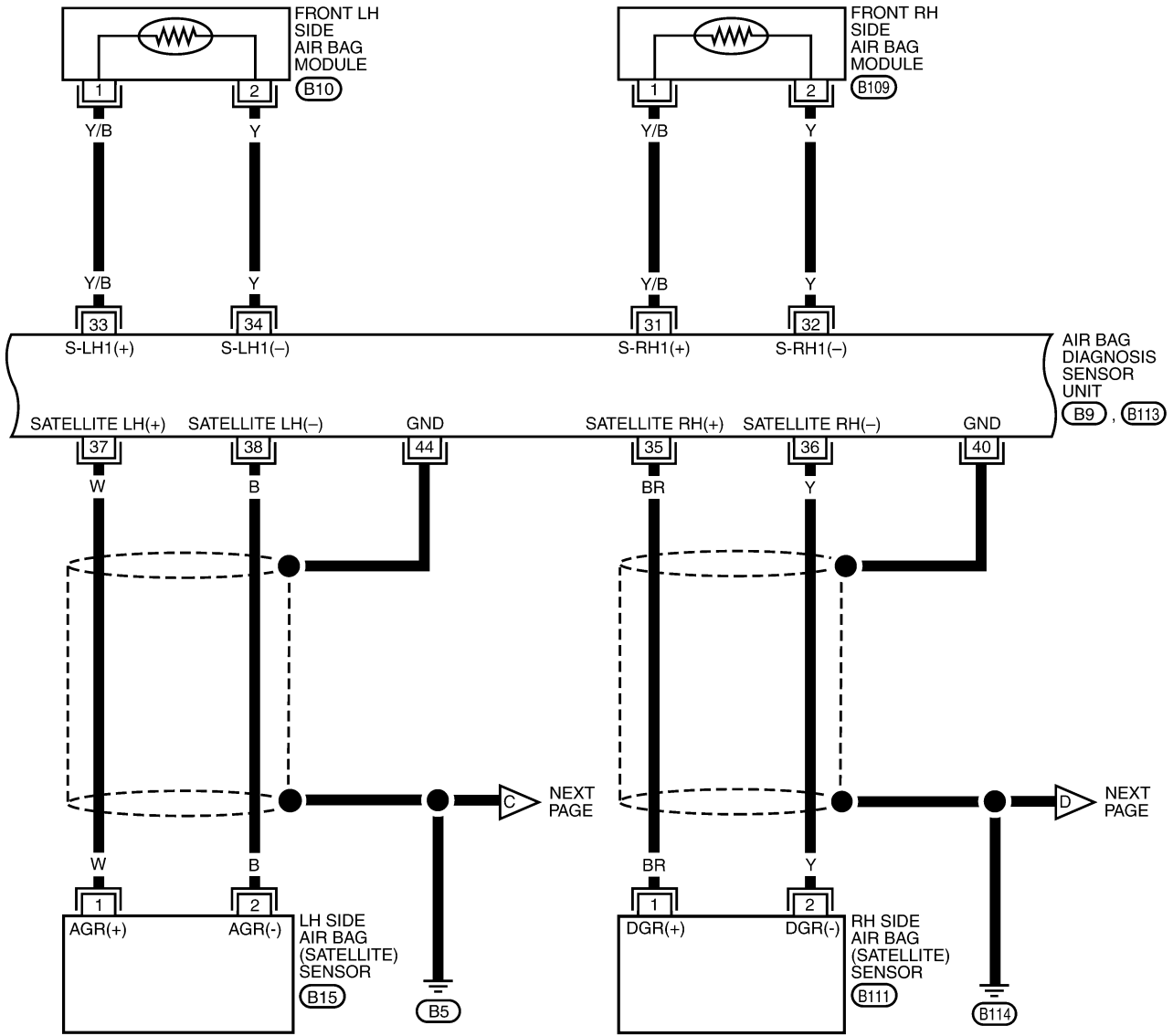

WHWA0299E

TROUBLE DIAGNOSIS

SRS-SRS-04

: WITH HATCHBACK

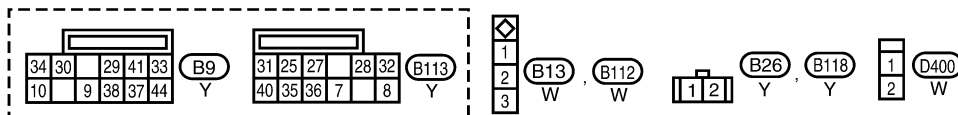
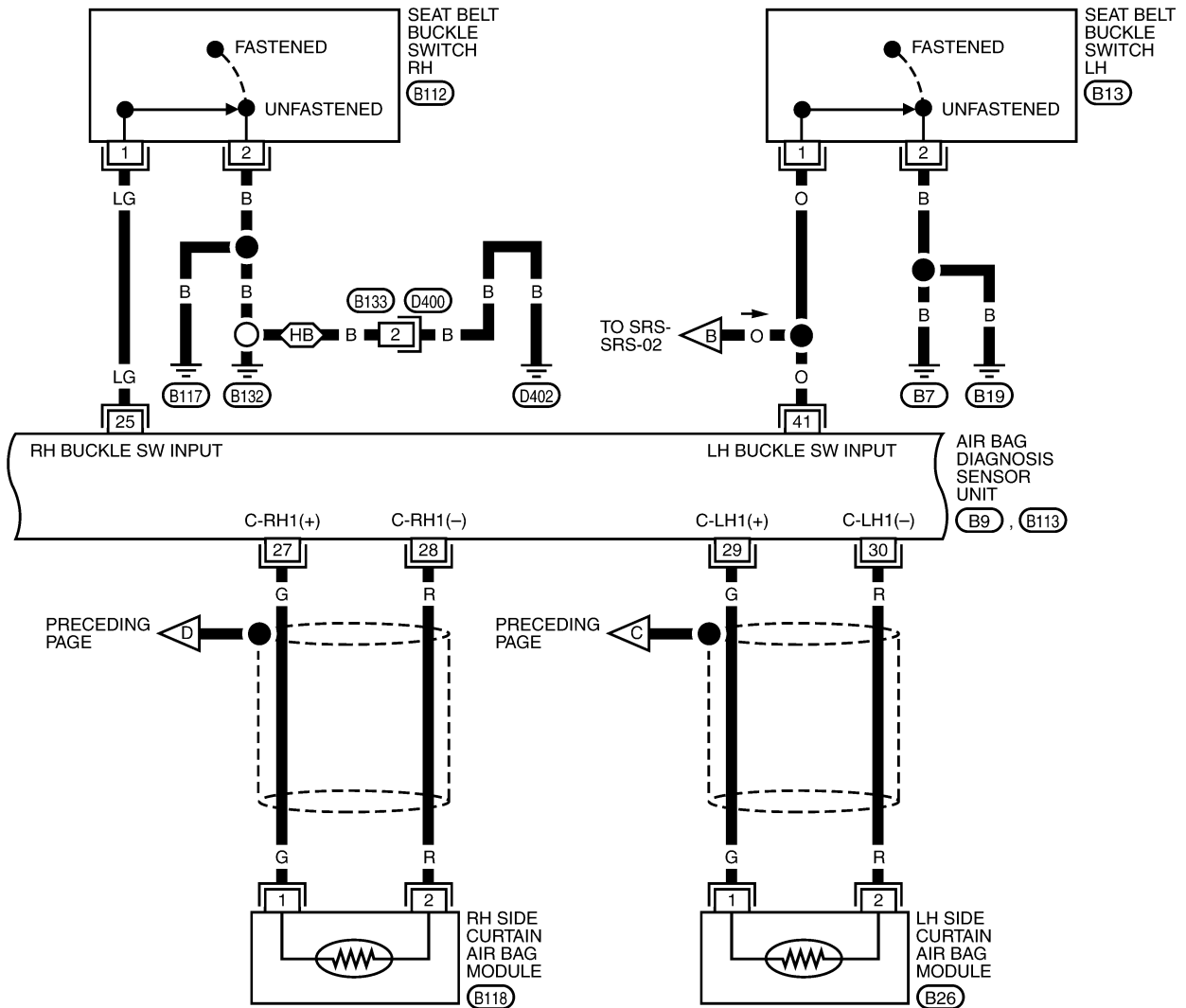

WHWA0348E

TROUBLE DIAGNOSIS

SRS-SRS-05

A
B
C
D
E
F
G
SRS
I
J
K
L
M

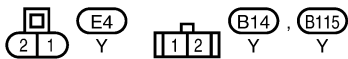
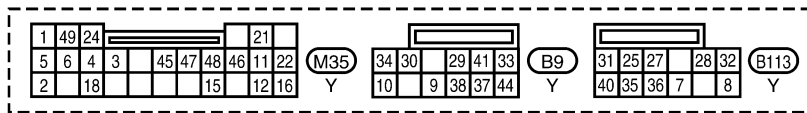
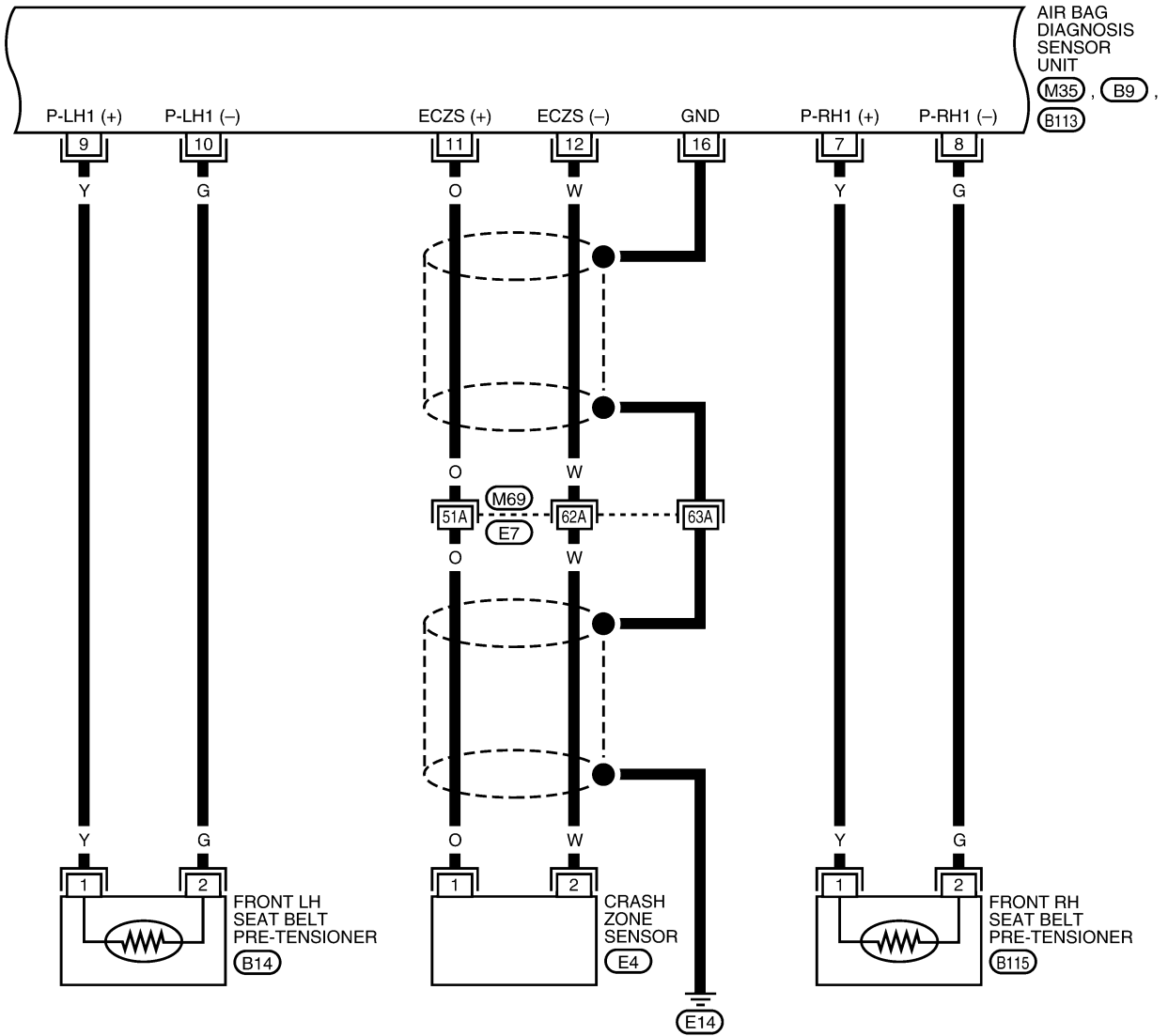

REFER TO THE FOLLOWING.
M69 - SUPER MULTIPLE JUNCTION (SMJ)

WHWA0301E

TROUBLE DIAGNOSIS

SRS-SRS-06

HB : WITH HATCHBACK

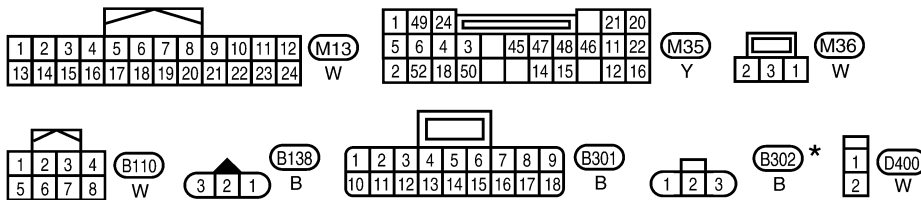
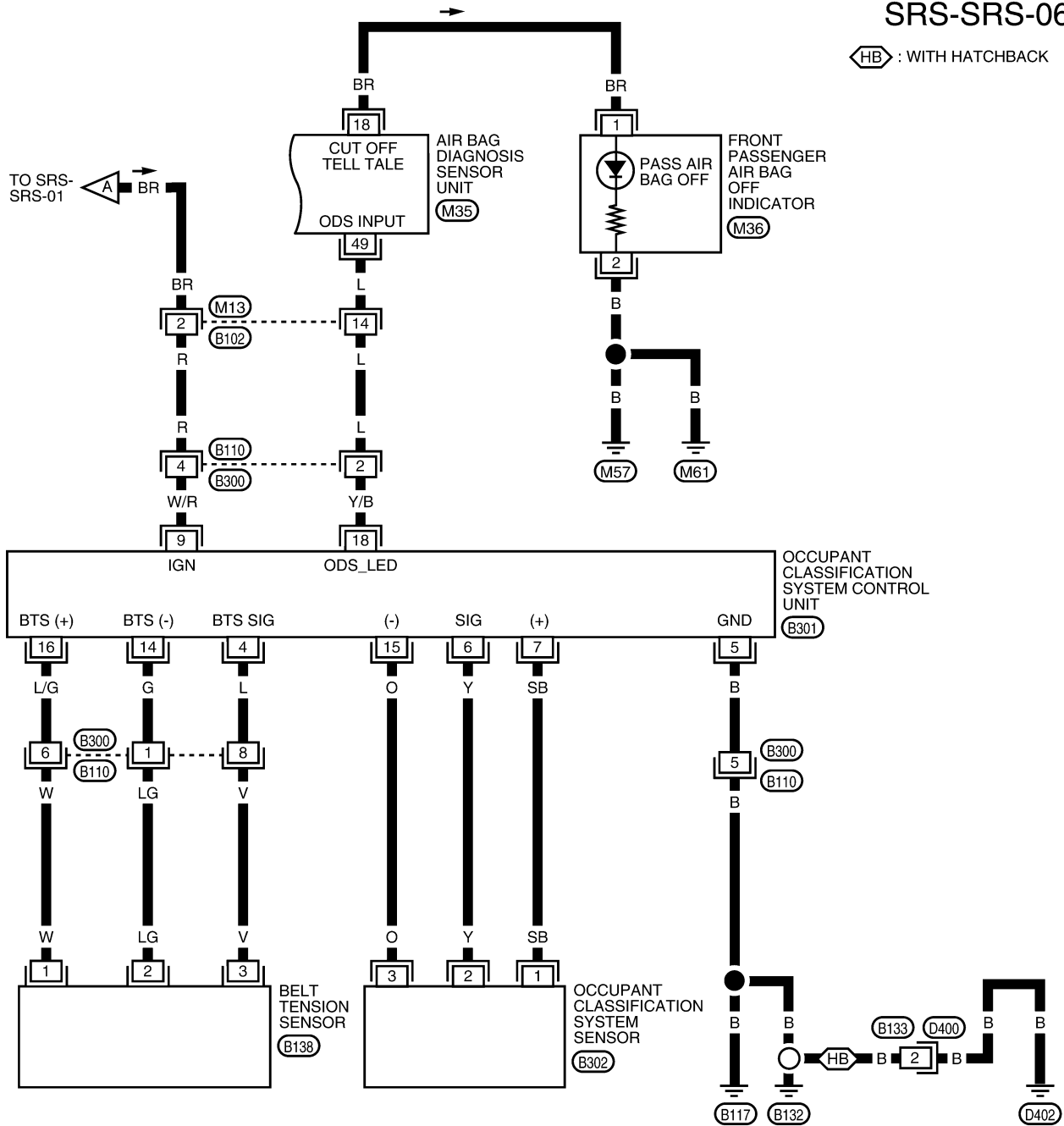

*: THIS CONNECTOR IS NOT SHOWN IN "HARNES LAYOUT" OF PG SECTION.

WHWA0349E

TROUBLE DIAGNOSIS

CONSULT-II Function (AIR BAG)

EHS001V1

CONSULT-II can display each diagnostic item using the diagnostic test modes shown following.

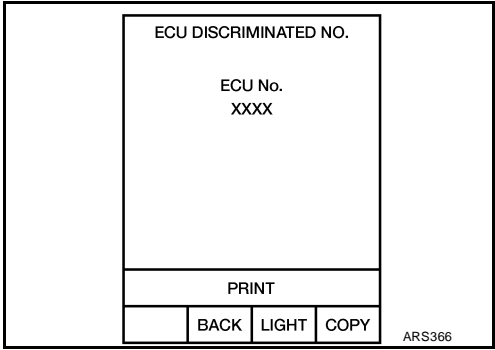
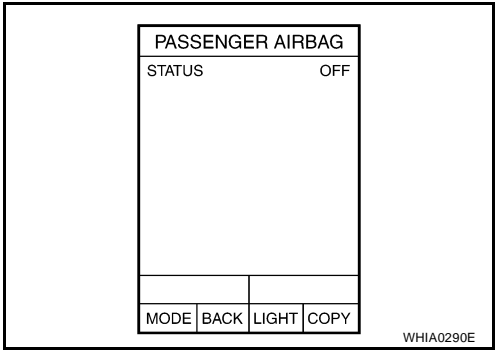
AIR BAG diagnostic mode	Description
SELF-DIAG [CURRENT]	A current Self-diagnosis result is displayed on the CONSULT-II screen in real time. This refers to a malfunctioning part requiring replacement.
SELF-DIAG [PAST]	Diagnosis results previously stored in the memory are displayed on the CONSULT-II screen. The stored results will remain until the memory is erased.
TROUBLE DIAG RECORD	With TROUBLE DIAG RECORD, diagnosis results previously erased by a reset operation can be displayed on the CONSULT-II screen.
ECU DISCRIMINATED NO.	<p>The air bag diagnosis sensor unit for each vehicle model is assigned with its own, individual classification number. This number will be displayed on the CONSULT-II screen, as shown. When replacing the air bag diagnosis sensor unit, refer to the part number for the compatibility. After installation, replacement with a correct unit can be checked by confirming this classification number on the CONSULT-II screen.</p> <p>The air bag diagnosis sensor unit discriminated number assigned is F636.</p> 
PASSENGER AIR BAG	<p>The STATUS (readiness) of the front passenger air bag module is displayed. The STATUS displayed (ON/OFF) depends on the signals supplied to the occupant classification system control module and air bag diagnosis sensor unit. Refer to SRS-6. "Occupant Classification System (OCS)" for more information.</p> 

A
B
C
D
E
F
G

SRS

I
J

HOW TO CHANGE BETWEEN SELF-DIAGNOSIS MODE AND USER MODE WITH CONSULT-II

From User Mode to Diagnosis Mode

After selecting "AIR BAG" on the "SELECT SYSTEM" screen, User mode automatically changes to Diagnosis mode.

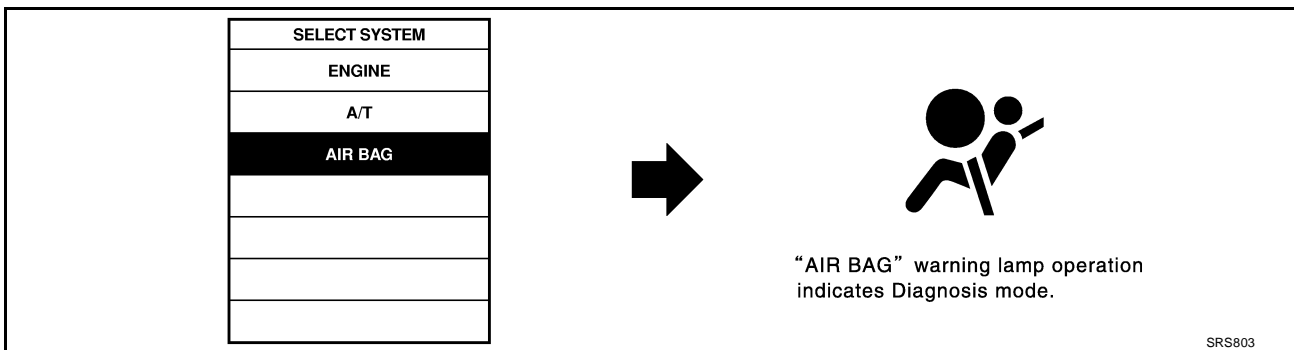

M

From Diagnosis Mode to User Mode

To return to User mode from Diagnosis mode, touch "BACK" key of CONSULT-II until "SELECT SYSTEM" appears, Diagnosis mode automatically changes to User mode.

TROUBLE DIAGNOSIS

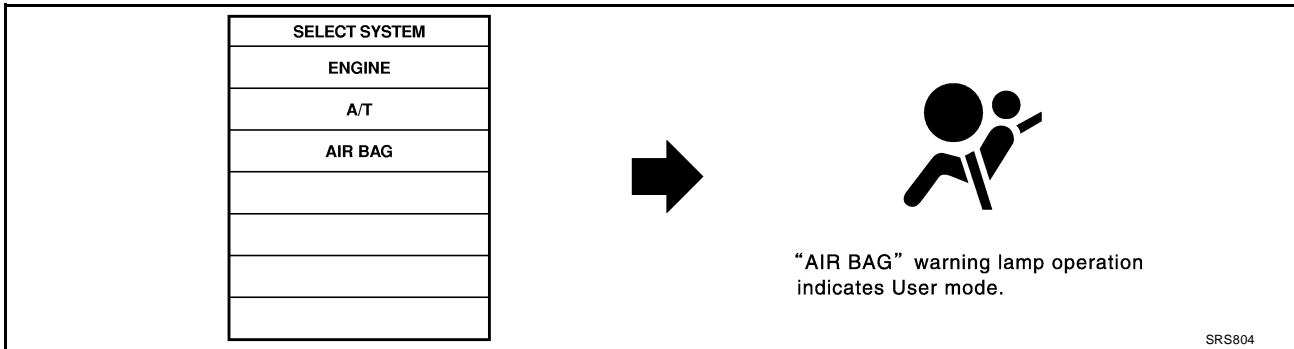

HOW TO ERASE SELF-DIAGNOSIS RESULTS

NOTE:

If the memory in “SELF-DIAG [PAST]” is not erased, User mode will continue to show the system malfunction by the operation of the warning lamp even if the malfunction is repaired completely.

- “SELF-DIAG [CURRENT]”

A current self-diagnosis result is displayed on the CONSULT-II screen in real time. After the malfunction is repaired completely, no malfunction is detected on “SELF-DIAG [CURRENT]”.

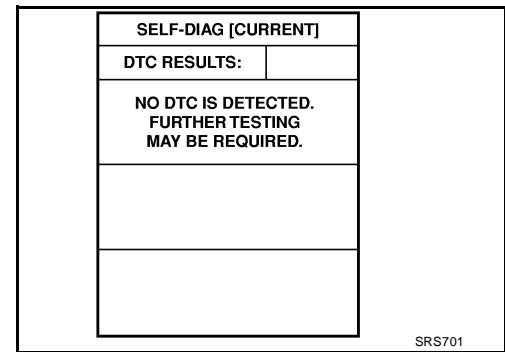

- “SELF-DIAG [PAST]”

Return to the “SELF-DIAG [CURRENT]” CONSULT-II screen by touching “BACK” key of CONSULT-II and select “SELF-DIAG [CURRENT]” in SELECT DIAG MODE. Touch “ERASE” in “SELF-DIAG [CURRENT]” mode.

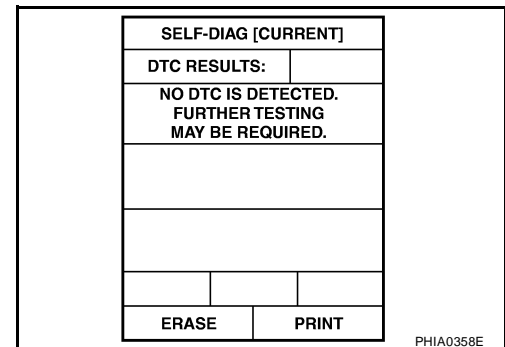

- “TROUBLE DIAG RECORD”

The memory of “TROUBLE DIAG RECORD” cannot be erased.

Self-Diagnosis Function (Without CONSULT-II)

EHS001V2

The reading of these results is accomplished using one of two modes — “User mode” and “Diagnosis mode”.

TROUBLE DIAGNOSIS

HOW TO CHANGE BETWEEN USER MODE AND SELF-DIAGNOSIS MODE WITHOUT CONSULT-II

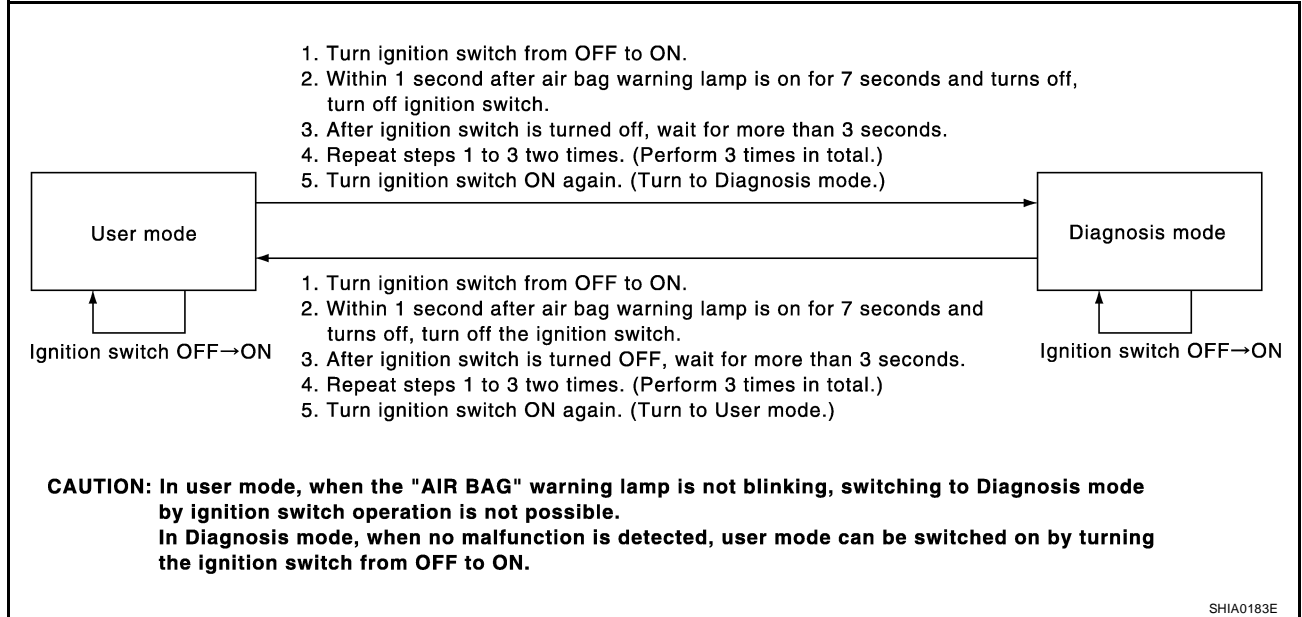

HOW TO ERASE SELF-DIAGNOSIS RESULTS

After a malfunction is repaired, turn the ignition switch OFF for at least one second, then back ON. Diagnosis mode returns to the User mode. At that time, the self-diagnostic result is cleared.

SRS Operation Check DIAGNOSTIC PROCEDURE 1

EHS001V3

Checking SRS Operation Using "AIR BAG" Warning Lamp—User Mode

1. Turn the ignition switch from OFF to ON, and check that the air bag warning lamp blinks.
2. Compare the SRS air bag warning lamp blinking pattern with the examples.

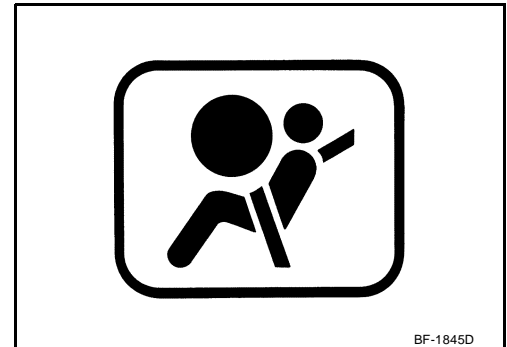

TROUBLE DIAGNOSIS

Air bag warning lamp examples

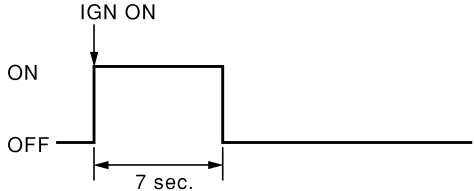
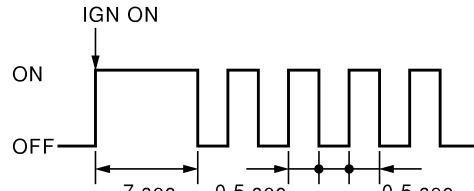
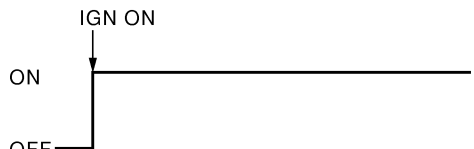
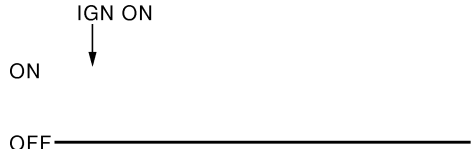
"AIR BAG" warning lamp operation-User mode-	SRS condition	Reference item
 <p style="text-align: right; font-size: small;">SHIA0011E</p>	<ul style="list-style-type: none"> ● No malfunction is detected. ● No further action is necessary. 	—
 <p style="text-align: right; font-size: small;">SHIA0012E</p>	<ul style="list-style-type: none"> ● The system is malfunctioning and needs to be repaired as indicated. 	<p>Go to SRS-23, "DIAGNOSTIC PROCEDURE 2" with CONSULT-II or SRS-34, "DIAGNOSTIC PROCEDURE 6" without CONSULT-II.</p>
 <p style="text-align: right; font-size: small;">SHIA0013E</p>	<ul style="list-style-type: none"> ● Air bag is deployed. ● Seat belt pre-tensioner is deployed. ● Air bag diagnosis sensor unit is malfunctioning. ● Air bag power supply circuit is malfunctioning. ● Air bag warning lamp circuit is malfunctioning. 	<p>Go to SRS-54, "COLLISION DIAGNOSIS" .</p> <p>Go to SRS-39, "Trouble Diagnosis: "AIR BAG" Warning Lamp Does Not Turn Off" .</p>
 <p style="text-align: right; font-size: small;">SHIA0014E</p>	<ul style="list-style-type: none"> ● Air bag diagnosis sensor unit is malfunctioning. ● Air bag warning lamp circuit is malfunctioning. 	<p>Go to SRS-40, "Trouble Diagnosis: "AIR BAG" Warning Lamp Does Not Turn On" .</p>

TROUBLE DIAGNOSIS

EHS001V4

Trouble Diagnosis With CONSULT-II DIAGNOSTIC PROCEDURE 2

Refer to [GI-38, "CONSULT-II Start Procedure"](#) .
Diagnostic code is displayed on "SELF-DIAG [CURRENT]".

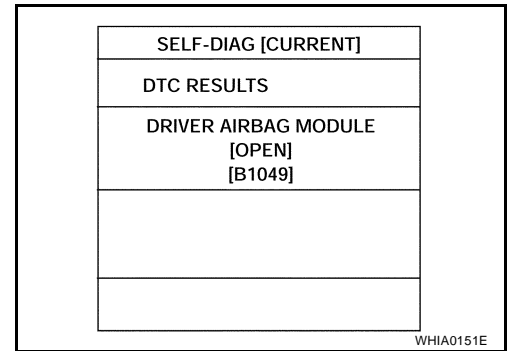

If no malfunction is detected on "SELF-DIAG [CURRENT]", but malfunction is detected in "SRS Operation Check", the following cases may exist:

- "SELF-DIAG [PAST]" memory might not be erased.
- The SRS system malfunctions intermittently.

Refer to [SRS-29, "DIAGNOSTIC PROCEDURE 4"](#)

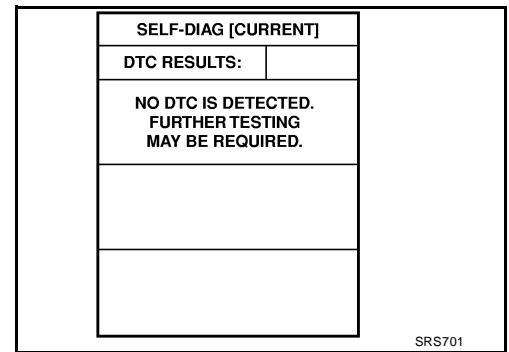

A
B
C
D
E
F
G

SRS

CONSULT-II Diagnostic Code Chart ("SELF-DIAG [CURRENT]")

Diagnostic item	Explanation		Repair order Recheck SRS at each replacement
NO DTC IS DETECTED	Malfunction is indicated by the "AIR BAG" warning lamp in User mode.	Low battery voltage (Less than 9V)	1. Go to SC-4, "BATTERY" 2. Go to SRS-27, "DIAGNOSTIC PROCEDURE 3" .
		"SELF-DIAG [PAST]" memory might not be erased.	Go to SRS-29, "DIAGNOSTIC PROCEDURE 4" .
		Intermittent malfunction has been detected in the past.	Go to SRS-29, "DIAGNOSTIC PROCEDURE 5" .
	No malfunction is detected in User mode.		—
DRIVER AIRBAG MODULE [OPEN] [B1049] or [B1054]	Driver air bag module circuit is open (including the spiral cable).		1. Visually check the wiring harness connection. 2. Replace the harness if it has visible damage. 3. Replace driver air bag module. 4. Replace the spiral cable. 5. Replace the air bag diagnosis sensor unit. 6. Replace the related harness.
DRIVER AIRBAG MODULE [VB-SHORT] [B1050] or [B1055]	Driver air bag module circuit is shorted to some power supply circuit (including the spiral cable).		
DRIVER AIRBAG MODULE [GND-SHORT] [B1051] or [B1056]	Driver air bag module circuit is shorted to ground (including the spiral cable).		
DRIVER AIRBAG MODULE [SHORT] [B1052] or [B1057]	Driver air bag module circuits are shorted to each other.		

I
J
K
L
M

TROUBLE DIAGNOSIS

Diagnostic item	Explanation	Repair order Recheck SRS at each replacement
ASSIST A/B MODULE [OPEN] [B1065] or [B1070]	Front passenger air bag module circuit is open.	<ol style="list-style-type: none"> 1. Visually check the wiring harness connection. 2. Replace the harness if it has visible damage. 3. Replace front passenger air bag module. 4. Replace the air bag diagnosis sensor unit. 5. Replace the related harness.
ASSIST A/B MODULE [VB-SHORT] [B1066] or [B1071]	Front passenger air bag module circuit is shorted to some power supply circuit.	
ASSIST A/B MODULE [GND-SHORT] [B1067] or [B1072]	Front passenger air bag module circuit is shorted to ground.	
ASSIST A/B MODULE [SHORT] [B1068] or [B1073]	Front passenger air bag module circuits are shorted to each other.	
CRASH ZONE SEN [UNIT FAIL] [B1033] or [B1034] CRASH ZONE SEN [COMM FAIL] [B1035]	Crash zone sensor	<ol style="list-style-type: none"> 1. Visually check the wiring harness connection. 2. Replace the harness if it has visible damage. 3. Replace the crash zone sensor. 4. Replace the air bag diagnosis sensor unit. 5. Replace the related harness.
SIDE MODULE LH [OPEN] [B1134]	Front LH side air bag module circuit is open.	<ol style="list-style-type: none"> 1. Visually check the wiring harness connection. 2. Replace the harness if it has visible damage. 3. Replace front LH seat back assembly (front LH side air bag module). 4. Replace the air bag diagnosis sensor unit. 5. Replace the related harness.
SIDE MODULE LH [VB-SHORT] [B1135]	Front LH side air bag module circuit is shorted to some power supply circuit.	
SIDE MODULE LH [GND-SHORT] [B1136]	Front LH side air bag module circuit is shorted to ground.	
SIDE MODULE LH [SHORT] [B1137]	Front LH side air bag module circuits are shorted to each other.	
SIDE MODULE RH [OPEN] [B1129]	Front RH side air bag module circuit is open.	<ol style="list-style-type: none"> 1. Visually check the wiring harness connection. 2. Replace the harness if it has visible damage. 3. Replace front RH seat back assembly (front RH side air bag module). 4. Replace the air bag diagnosis sensor unit. 5. Replace the related harness.
SIDE MODULE RH [VB-SHORT] [B1130]	Front RH side air bag module circuit is shorted to some power supply circuit.	
SIDE MODULE RH [GND-SHORT] [B1131]	Front RH side air bag module circuit is shorted to ground.	
SIDE MODULE RH [SHORT] [B1132]	Front RH side air bag module circuits are shorted to each other.	
SATELLITE SENS LH [UNIT FAIL] [B1118] or [B1119] SATELLITE SENS LH [COMM FAIL] [B1120]	LH side air bag (satellite) sensor	<ol style="list-style-type: none"> 1. Visually check the wiring harness connection. 2. Replace the harness if it has visible damage. 3. Replace the LH side air bag (satellite) sensor. 4. Replace the air bag diagnosis sensor unit. 5. Replace the related harness.

TROUBLE DIAGNOSIS

Diagnostic item	Explanation	Repair order Recheck SRS at each replacement	
SATELLITE SENS RH [UNIT FAIL] [B1113] or [B1114] SATELLITE SENS RH [COMM FAIL] [B1115]	RH side air bag (satellite) sensor	<ol style="list-style-type: none"> 1. Visually check the wiring harness connection. 2. Replace the harness if it has visible damage. 3. Replace the RH side air bag (satellite) sensor. 4. Replace the air bag diagnosis sensor unit. 5. Replace the related harness. 	A B C
PRE-TEN FRONT LH [OPEN] [B1086]	The circuit for front LH seat belt pre-tensioner is open.	<ol style="list-style-type: none"> 1. Visually check the wiring harness connections. 2. Replace the harness if it has visible damage. 	D
PRE-TEN FRONT LH [VB-SHORT] [B1087]	The circuit for front LH seat belt pre-tensioner is shorted to some power supply circuit.	<ol style="list-style-type: none"> 3. Replace front LH seat belt pre-tensioner. 	E
PRE-TEN FRONT LH [GND-SHORT] [B1088]	The circuit for front LH seat belt pre-tensioner is shorted to ground.	<ol style="list-style-type: none"> 4. Replace the air bag diagnosis sensor unit. 	F
PRE-TEN FRONT LH [SHORT] [B1089]	The circuits for the front LH seat belt pre-tensioner are shorted to each other.	<ol style="list-style-type: none"> 5. Replace the related harness. 	G
PRE-TEN FRONT RH [OPEN] [B1081]	The circuit for front RH seat belt pre-tensioner is open.	<ol style="list-style-type: none"> 1. Visually check the wiring harness connections. 	SRS
PRE-TEN FRONT RH [VB-SHORT] [B1082]	The circuit for front RH seat belt pre-tensioner is shorted to some power supply circuit.	<ol style="list-style-type: none"> 2. Replace the harness if it has visible damage. 3. Replace front RH seat belt pre-tensioner. 	I
PRE-TEN FRONT RH [GND-SHORT] [B1083]	The circuit for front RH seat belt pre-tensioner is shorted to ground.	<ol style="list-style-type: none"> 4. Replace the air bag diagnosis sensor unit. 	J
PRE-TEN FRONT RH [SHORT] [B1084]	The circuits for the front RH seat belt pre-tensioner are shorted to each other.	<ol style="list-style-type: none"> 5. Replace the related harness. 	K
CURTAIN MODULE LH [OPEN] [B1150]	The LH side curtain air bag module circuit is open.	<ol style="list-style-type: none"> 1. Visually check the wiring harness connection. 	L
CURTAIN MODULE LH [VB-SHORT] [B1151]	The LH side curtain air bag module circuit is shorted to some power supply circuits.	<ol style="list-style-type: none"> 2. Replace the harness if it has visible damage. 3. Replace LH side curtain air bag module. 	M
CURTAIN MODULE LH [GND-SHORT] [B1152]	The LH side curtain air bag module circuit is shorted to ground.	<ol style="list-style-type: none"> 4. Replace the air bag diagnosis sensor unit. 	
CURTAIN MODULE LH [SHORT] [B1153]	The circuits for the LH side curtain air bag module are shorted to each other.	<ol style="list-style-type: none"> 5. Replace the related harness. 	

TROUBLE DIAGNOSIS

Diagnostic item	Explanation	Repair order Recheck SRS at each replacement
CURTAIN MODULE RH [OPEN] [B1145]	The RH side curtain air bag module circuit is open.	<ol style="list-style-type: none"> 1. Visually check the wiring harness connection. 2. Replace the harness if it has visible damage. 3. Replace RH side curtain air bag module. 4. Replace the air bag diagnosis sensor unit. 5. Replace the related harness.
CURTAIN MODULE RH [VB-SHORT] [B1146]	The RH side curtain air bag module circuit is shorted to some power supply circuits.	
CURTAIN MODULE RH [GND-SHORT] [B1147]	The RH side curtain air bag module circuit is shorted to ground.	
CURTAIN MODULE RH [SHORT] [B1148]	The circuits for the RH side curtain air bag module are shorted to each other.	
CONTROL UNIT [B1XXX]	Air bag diagnosis sensor unit is malfunctioning.	<ol style="list-style-type: none"> 1. Visually check the wiring harness connection. 2. Replace the air bag diagnosis sensor unit.
OCCUPANT SENS C/U [UNIT FAIL] [B1017], [B1020] or [B1021]	Occupant classification system is malfunctioning.	<ol style="list-style-type: none"> 1. Replace RH front seat cushion/ occupant classification system control unit assembly.
OCCUPANT SENS C/U [COMM FAIL] [B1022]	Communication between the occupant classification system control unit and air bag diagnosis sensor unit is interrupted.	<ol style="list-style-type: none"> 1. Visually check the wiring harness connection. 2. Replace the harness if it has visible damage. 3. Replace RH front seat cushion/ occupant classification system control unit assembly. 4. Replace the air bag diagnosis sensor unit. 5. Replace the related harness.
OCCUPANT SENS [UNIT FAIL] [B1018]	Occupant classification sensor is malfunctioning.	<ol style="list-style-type: none"> 1. Replace RH front seat cushion/ occupant classification system control unit assembly.
BELT TENSION SENS [UNIT FAIL] [B1019]	Belt tension sensor is malfunctioning.	<ol style="list-style-type: none"> 1. Visually check the wiring harness connection. 2. Replace the harness if it has visible damage. 3. Replace RH front seat belt assembly. 4. Replace RH front seat cushion/ occupant classification system control unit assembly.
PASS A/B INDCTR CKT [B1023]	Front passenger air bag off indicator is malfunctioning.	<ol style="list-style-type: none"> 1. Visually check the wiring harness connection. 2. Replace the harness if it has visible damage. 3. Replace front passenger air bag off indicator. 4. Replace the air bag diagnosis sensor unit. 5. Replace the related harness.

TROUBLE DIAGNOSIS

Diagnostic item	Explanation	Repair order Recheck SRS at each replacement
FRONTAL COLLISION DETECTION [B1209]	Driver and front passenger air bag modules are deployed.	Refer to SRS-54, "COLLISION DIAGNOSIS" .
SIDE COLLISION DETECTION [B1210]	Side or curtain air bag modules are deployed.	

NOTE:

Follow the procedures in numerical order when performing repairs. Confirm whether the repair has been successful using air bag warning lamp or CONSULT-II after each repair. If malfunction is still observed, proceed to the next step. When malfunction has been eliminated, further repair work is not required.

DIAGNOSTIC PROCEDURE 3

Final Check of SRS Using CONSULT-II—Diagnosis Mode

Refer to [GI-38, "CONSULT-II Start Procedure"](#) .

- If no DTC is detected on "SELF-DIAG [CURRENT]", repair of SRS is completed. Go to step 2.
If any DTC is detected on "SELF-DIAG [CURRENT]", the malfunctioning part has not been repaired completely or another malfunctioning part is being detected. Go to [SRS-23, "DIAGNOSTIC PROCEDURE 2"](#) .

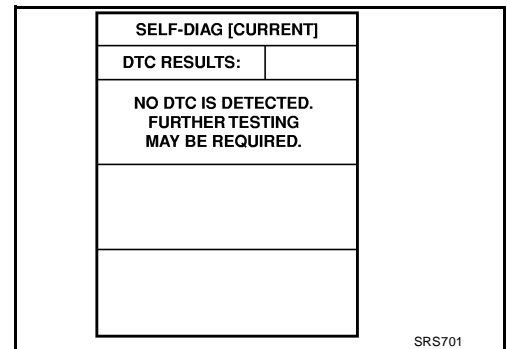

- Touch "ERASE".

NOTE:

Touch "ERASE" to clear the memory of the malfunction ("SELF-DIAG [PAST]").

If the memory of the malfunction in "SELF-DIAG [PAST]" is not erased, the User mode shows the system malfunction by the operation of the warning lamp even if the malfunction is repaired completely.

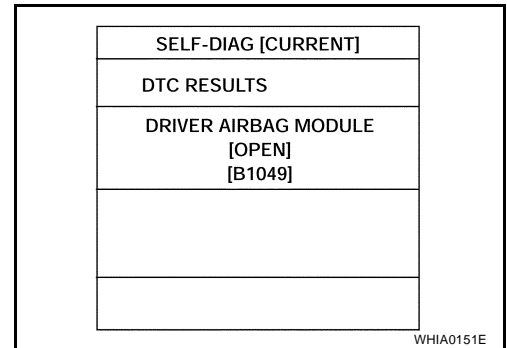

- Touch "BACK" key of CONSULT-II to "SELECT DIAG MODE" screen. Touch "SELF-DIAG [PAST]".

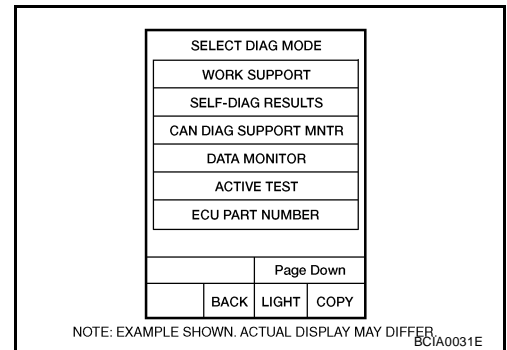

TROUBLE DIAGNOSIS

4. Check that no malfunction is detected on "SELF-DIAG [PAST]".
5. Touch "BACK" key of CONSULT-II until "SELECT SYSTEM" appears in order to return to User mode from Diagnosis mode.
6. Turn ignition switch OFF then turn off and disconnect CONSULT-II.
7. Go to [SRS-21, "Checking SRS Operation Using "AIR BAG" Warning Lamp—User Mode"](#) .

SELF-DIAG [PAST]	
DTC RESULTS:	
NO DTC IS DETECTED. FURTHER TESTING MAY BE REQUIRED.	

SRS702

TROUBLE DIAGNOSIS

DIAGNOSTIC PROCEDURE 4

Check SRS Repair History

1. CONSIDER POSSIBILITY THAT SELF-DIAGNOSTIC RESULT WAS NOT ERASED AFTER REPAIR

Check repair history of the SRS.

Have any previous repairs been made to the SRS?

- Yes >> Self-diagnostic result "SELF-DIAG [PAST]" (previously stored in the memory) might not be erased after repair. Go to [SRS-27, "DIAGNOSTIC PROCEDURE 3"](#) .
- No >> Go to [SRS-23, "DIAGNOSTIC PROCEDURE 2"](#) .

DIAGNOSTIC PROCEDURE 5

Check SRS Intermittent Malfunction Using CONSULT-II—Diagnosis Mode

Refer to [GI-38, "CONSULT-II Start Procedure"](#) .

1. If diagnostic codes are displayed on "SELF-DIAG [PAST]", go to step 4.

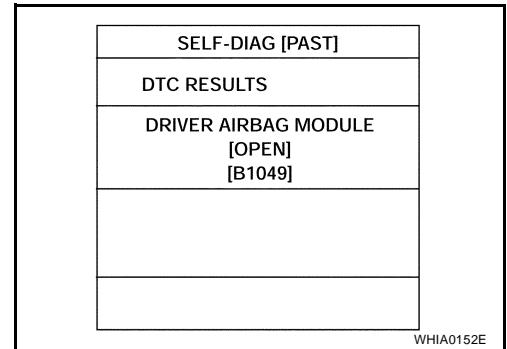

If no malfunction is detected on "SELF-DIAG [PAST]", touch "BACK" and go back to "SELECT DIAG MODE".

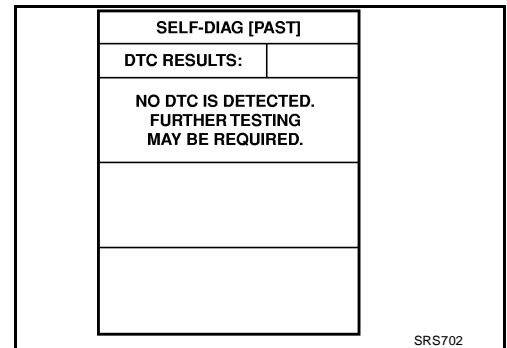

2. Touch "TROUBLE DIAG RECORD".

NOTE:

With "TROUBLE DIAG RECORD", diagnosis results previously erased by a reset operation can be displayed.

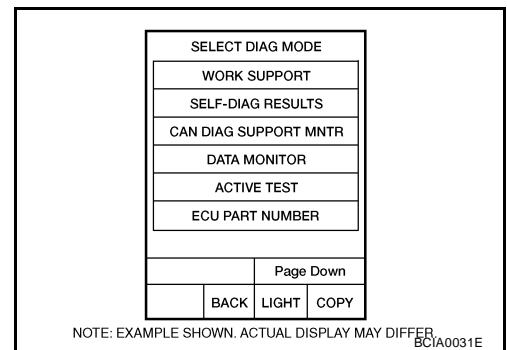

TROUBLE DIAGNOSIS

3. Diagnostic code is displayed on "TROUBLE DIAG RECORD".
4. Touch "PRINT".
5. Compare diagnostic codes to [SRS-30, "CONSULT-II Diagnostic Code Chart \("SELF-DIAG \[PAST\]" or "TROUBLE DIAG RECORD"\)"](#) .
6. Touch "BACK" key of CONSULT-II until "SELECT SYSTEM" appears.
7. Turn ignition switch OFF, then turn off and disconnect CONSULT-II, and both battery cables.
8. Repair the system as outlined by the "Repair order" in "Intermittent Malfunction Diagnostic Code Chart", that corresponds to the self-diagnostic result. For replacement procedure of component parts, refer to the Removal and Installation procedure for the appropriate component.
9. Go to [SRS-27, "DIAGNOSTIC PROCEDURE 3"](#) , for final checking.

TROUBLE DIAG RECORD
DTC RESULTS
DRIVER AIRBAG MODULE [OPEN] [B1049]

WHIA0153E

CONSULT-II Diagnostic Code Chart ("SELF-DIAG [PAST]" or "TROUBLE DIAG RECORD")

Diagnostic item	Explanation	Repair order Recheck SRS at each replacement
NO DTC IS DETECTED	When malfunction is indicated by the "AIR BAG" warning lamp in User mode.	<ul style="list-style-type: none"> ● Low battery voltage (Less than 9V) ● Self-diagnostic result "SELF-DIAG [PAST]" (previously stored in the memory) might not be erased after repair. ● Intermittent malfunction has been detected in the past.
	<ul style="list-style-type: none"> ● No malfunction is detected. 	—
DRIVER AIRBAG MODULE [OPEN] [B1049] or [B1054]	Driver air bag module circuit is open (including the spiral cable).	1. Visually check the wiring harness connection. 2. Replace the harness if it has visible damage. 3. Replace driver air bag module. 4. Replace the spiral cable. 5. Replace the air bag diagnosis sensor unit. 6. Replace the related harness.
DRIVER AIRBAG MODULE [VB-SHORT] [B1050] or [B1055]	Driver air bag module circuit is shorted to some power supply circuit (including the spiral cable).	
DRIVER AIRBAG MODULE [GND-SHORT] [B1051] or [B1056]	Driver air bag module circuit is shorted to ground (including the spiral cable).	
DRIVER AIRBAG MODULE [SHORT] [B1052] or [B1057]	Driver air bag module circuits are shorted to each other.	
ASSIST A/B MODULE [OPEN] [B1065] or [B1070]	Front passenger air bag module circuit is open.	1. Visually check the wiring harness connection. 2. Replace the harness if it has visible damage. 3. Replace front passenger air bag module. 4. Replace the air bag diagnosis sensor unit. 5. Replace the related harness.
ASSIST A/B MODULE [VB-SHORT] [B1066] or [B1071]	Front passenger air bag module circuit is shorted to some power supply circuit.	
ASSIST A/B MODULE [GND-SHORT] [B1067] or [B1072]	Front passenger air bag module circuit is shorted to ground.	
ASSIST A/B MODULE [SHORT] [B1068] or [B1073]	Front passenger air bag module circuits are shorted to each other.	

TROUBLE DIAGNOSIS

Diagnostic item	Explanation	Repair order Recheck SRS at each replacement	
CRASH ZONE SEN [UNIT FAIL] [B1033] or [B1034] CRASH ZONE SEN [COMM FAIL] [B1035]	Crash zone sensor	1. Visually check the wiring harness connection. 2. Replace the harness if it has visible damage. 3. Replace the crash zone sensor. 4. Replace the air bag diagnosis sensor unit. 5. Replace the related harness.	A B C
SIDE MODULE LH [OPEN] [B1134]	Front LH side air bag module circuit is open.	1. Visually check the wiring harness connection. 2. Replace the harness if it has visible damage.	D
SIDE MODULE LH [VB-SHORT] [B1135]	Front LH side air bag module circuit is shorted to some power supply circuit.	3. Replace front LH seat back assembly (front LH side air bag module).	E
SIDE MODULE LH [GND-SHORT] [B1136]	Front LH side air bag module circuit is shorted to ground.	4. Replace the air bag diagnosis sensor unit. 5. Replace the related harness.	F
SIDE MODULE LH [SHORT] [B1137]	Front LH side air bag module circuits are shorted to each other.		G
SIDE MODULE RH [OPEN] [B1129]	Front RH side air bag module circuit is open.	1. Visually check the wiring harness connection. 2. Replace the harness if it has visible damage.	SRS
SIDE MODULE RH [VB-SHORT] [B1130]	Front RH side air bag module circuit is shorted to some power supply circuit.	3. Replace front RH seat back assembly (front RH side air bag module).	I
SIDE MODULE RH [GND-SHORT] [B1131]	Front RH side air bag module circuit is shorted to ground.	4. Replace the air bag diagnosis sensor unit. 5. Replace the related harness.	J
SIDE MODULE RH [SHORT] [B1132]	Front RH side air bag module circuits are shorted to each other.		K
SATELLITE SENS LH [UNIT FAIL] [B1118] or [B1119] SATELLITE SENS LH [COMM FAIL] [B1120]	LH side air bag (satellite) sensor	1. Visually check the wiring harness connection. 2. Replace the harness if it has visible damage. 3. Replace the LH side air bag (satellite) sensor. 4. Replace the air bag diagnosis sensor unit. 5. Replace the related harness.	L M
SATELLITE SENS RH [UNIT FAIL] [B1113] or [B1114] SATELLITE SENS RH [COMM FAIL] [B1115]	RH side air bag (satellite) sensor	1. Visually check the wiring harness connection. 2. Replace the harness if it has visible damage. 3. Replace the RH side air bag (satellite) sensor. 4. Replace the air bag diagnosis sensor unit. 5. Replace the related harness.	

TROUBLE DIAGNOSIS

Diagnostic item	Explanation	Repair order Recheck SRS at each replacement
PRE-TEN FRONT LH [OPEN] [B1086]	The circuit for front LH seat belt pre-tensioner is open.	<ol style="list-style-type: none"> 1. Visually check the wiring harness connections. 2. Replace the harness if it has visible damage. 3. Replace front LH seat belt pre-tensioner. 4. Replace the air bag diagnosis sensor unit. 5. Replace the related harness.
PRE-TEN FRONT LH [VB-SHORT] [B1087]	The circuit for front LH seat belt pre-tensioner is shorted to some power supply circuit.	
PRE-TEN FRONT LH [GND-SHORT] [B1088]	The circuit for front LH seat belt pre-tensioner is shorted to ground.	
PRE-TEN FRONT LH [SHORT] [B1089]	The circuits for the front LH seat belt pre-tensioner are shorted to each other.	
PRE-TEN FRONT RH [OPEN] [B1081]	The circuit for front RH seat belt pre-tensioner is open.	<ol style="list-style-type: none"> 1. Visually check the wiring harness connections. 2. Replace the harness if it has visible damage. 3. Replace front RH seat belt pre-tensioner. 4. Replace the air bag diagnosis sensor unit. 5. Replace the related harness.
PRE-TEN FRONT RH [VB-SHORT] [B1082]	The circuit for front RH seat belt pre-tensioner is shorted to some power supply circuit.	
PRE-TEN FRONT RH [GND-SHORT] [B1083]	The circuit for front RH seat belt pre-tensioner is shorted to ground.	
PRE-TEN FRONT RH [SHORT] [B1084]	The circuits for the front RH seat belt pre-tensioner are shorted to each other.	
CURTAIN MODULE LH [OPEN] [B1150]	The LH side curtain air bag module circuit is open.	<ol style="list-style-type: none"> 1. Visually check the wiring harness connection. 2. Replace the harness if it has visible damage. 3. Replace LH side curtain air bag module. 4. Replace the air bag diagnosis sensor unit. 5. Replace the related harness.
CURTAIN MODULE LH [VB-SHORT] [B1151]	The LH side curtain air bag module circuit is shorted to some power supply circuits.	
CURTAIN MODULE LH [GND-SHORT] [B1152]	The LH side curtain air bag module circuit is shorted to ground.	
CURTAIN MODULE LH [SHORT] [B1153]	The circuits for the LH side curtain air bag module are shorted to each other.	
CURTAIN MODULE RH [OPEN] [B1145]	The RH side curtain air bag module circuit is open.	<ol style="list-style-type: none"> 1. Visually check the wiring harness connection. 2. Replace the harness if it has visible damage. 3. Replace RH side curtain air bag module. 4. Replace the air bag diagnosis sensor unit. 5. Replace the related harness.
CURTAIN MODULE RH [VB-SHORT] [B1146]	The RH side curtain air bag module circuit is shorted to some power supply circuits.	
CURTAIN MODULE RH [GND-SHORT] [B1147]	The RH side curtain air bag module circuit is shorted to ground.	
CURTAIN MODULE RH [SHORT] [B1148]	The circuits for the RH side curtain air bag module are shorted to each other.	
CONTROL UNIT [B1XXX]	Air bag diagnosis sensor unit is malfunctioning.	<ol style="list-style-type: none"> 1. Visually check the wiring harness connection. 2. Replace the air bag diagnosis sensor unit.
OCCUPANT SENS C/U [UNIT FAIL] [B1017], [B1020] or [B1021]	Occupant classification system is malfunctioning.	<ol style="list-style-type: none"> 1. Replace RH front seat cushion/occupant classification system control unit assembly.

TROUBLE DIAGNOSIS

Diagnostic item	Explanation	Repair order Recheck SRS at each replacement	A
OCCUPANT SENS C/U [COMM FAIL] [B1022]	Communication between the occupant classification system control unit and air bag diagnosis sensor unit is interrupted.	<ol style="list-style-type: none"> 1. Visually check the wiring harness connection. 2. Replace the harness if it has visible damage. 3. Replace RH front seat cushion/ occupant classification system control unit assembly. 4. Replace the air bag diagnosis sensor unit. 5. Replace the related harness. 	B C D
OCCUPANT SENS [UNIT FAIL] [B1018]	Occupant classification sensor is malfunctioning.	<ol style="list-style-type: none"> 1. Replace RH front seat cushion/ occupant classification system control unit assembly. 	E
BELT TENSION SENS [UNIT FAIL] [B1019]	Belt tension sensor is malfunctioning.	<ol style="list-style-type: none"> 1. Visually check the wiring harness connection. 2. Replace the harness if it has visible damage. 3. Replace RH front seat belt assembly. 4. Replace RH front seat cushion/ occupant classification system control unit assembly. 	F G
PASS A/B INDCTR CKT [B1023]	Front passenger air bag off indicator is malfunctioning.	<ol style="list-style-type: none"> 1. Visually check the wiring harness connection. 2. Replace the harness if it has visible damage. 3. Replace front passenger air bag off indicator. 4. Replace the air bag diagnosis sensor unit. 5. Replace the related harness. 	SRS I J
FRONTAL COLLISION DETECTION [B1209]	Driver and front passenger air bag modules are deployed.	Refer to SRS-54, "COLLISION DIAGNOSIS" .	K
SIDE COLLISION DETECTION [B1210]	Side or curtain air bag modules are deployed.		L

NOTE:

Follow the procedures in numerical order when performing repairs. Confirm whether the repair has been successful using air bag warning lamp or CONSULT-II after each repair. If malfunction is still observed, proceed to the next step. When malfunction has been eliminated, further repair work is not required.

TROUBLE DIAGNOSIS

Trouble Diagnosis Without CONSULT-II

EHS001V5

DIAGNOSTIC PROCEDURE 6

Inspect SRS Malfunction Using "AIR BAG" Warning Lamp—Diagnosis Mode

NOTE:

SRS will not enter Diagnosis mode if no malfunction is detected in User mode.

1. Turn ignition switch ON.
2. After "AIR BAG" warning lamp lights for 7 seconds, turn ignition switch OFF within 1 second.
3. Wait more than 3 seconds.
4. Repeat steps 1 to 3 two times.
5. Turn ignition switch ON.

SRS is now in Diagnosis mode.

"AIR BAG" warning lamp operates in Diagnosis mode according to the Warning Lamp Flash Code Chart:

TROUBLE DIAGNOSIS

WARNING LAMP FLASH CODE CHART

<Diagnosis results (previously stored in the memory) might not be erased after repair or intermittent malfunctions have been detected in the past.>

Flash pattern	Repair order
<p>a through b are repeated.</p>	<p>1. Go to DIAGNOSTIC PROCEDURES 2 and 3.</p>

SHIA0026E

<Driver air bag module>	
Flash pattern	Repair order
<p>a through d are repeated. d: Two flashes indicate malfunctioning driver air bag module circuits.</p>	<ol style="list-style-type: none"> 1. Visually check the wiring harness connection. 2. Replace the harness if it has visible damage. 3. Replace the spiral cable. 4. Replace driver air bag module. 5. Replace the air bag diagnosis sensor unit. 6. Replace the related harness.

WHIA00260E

<Air bag diagnosis sensor unit>	
Flash pattern	Repair order
<p>a through d are repeated. d: Seven flashes indicate malfunctioning diagnosis sensor unit circuit.</p>	<ol style="list-style-type: none"> 1. Visually check the wiring harness connections. 2. Replace the harness if it has visible damage. 3. Replace the air bag diagnosis sensor unit. 4. Replace the related harness.

WHIA0198E

<Front passenger air bag module>	
Flash pattern	Repair order
<p>a through d are repeated. d: Eight flashes indicate malfunctioning front passenger air bag module circuit.</p>	<ol style="list-style-type: none"> 1. Visually check the wiring harness connection. 2. Replace the harness if it has visible damage. 3. Replace front passenger air bag module. 4. Replace the air bag diagnosis sensor unit. 5. Replace the related harness.

WHIA0261E

TROUBLE DIAGNOSIS

<Crash zone sensor>	
<p>Flash pattern</p> <p>a through d are repeated. d: Six flashes indicate malfunctioning crash zone sensor circuit.</p>	<p>Repair order</p> <ol style="list-style-type: none"> 1. Visually check the wiring harness connection. 2. Replace the harness if it has visible damage. 3. Replace the crash zone sensor. 4. Replace the air bag diagnosis sensor unit. 5. Replace the related harness.
WHIA0200E	

<Front RH seat belt pre-tensioner>	
<p>Flash pattern</p> <p>a through d are repeated. d: One flash indicates malfunctioning front RH seat belt pre-tensioner circuit.</p>	<p>Repair order</p> <ol style="list-style-type: none"> 1. Visually check the wiring harness connections. 2. Replace the harness if it has visible damage. 3. Replace front RH seat belt pre-tensioner. 4. Replace the air bag diagnosis sensor unit. 5. Replace the related harness.
WHIA0262E	

<Front LH seat belt pre-tensioner>	
<p>Flash pattern</p> <p>a through d are repeated. d: Three flashes indicate malfunctioning front LH seat belt pre-tensioner circuit.</p>	<p>Repair order</p> <ol style="list-style-type: none"> 1. Visually check the wiring harness connections. 2. Replace the harness if it has visible damage. 3. Replace front LH seat belt pre-tensioner. 4. Replace the air bag diagnosis sensor unit. 5. Replace the related harness.
WHIA0263E	

<RH side air bag (Satellite) sensor>	
<p>Flash pattern</p> <p>a through f are repeated. f: Three flashes indicate malfunctioning RH side air bag (Satellite) sensor circuit.</p>	<p>Repair order</p> <ol style="list-style-type: none"> 1. Visually check the wiring harness connection. 2. Replace the harness if it has visible damage. 3. Replace the RH side air bag (Satellite) sensor. 4. Replace the air bag diagnosis sensor unit. 5. Replace the related harness.
WHIA0203E	

TROUBLE DIAGNOSIS

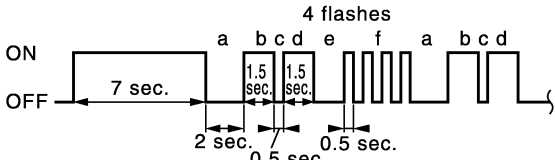
<LH side air bag (Satellite) sensor>	
Flash pattern	Repair order
<p>a through f are repeated. f: Four flashes indicate malfunctioning LH side air bag (Satellite) sensor.</p> 	<ol style="list-style-type: none"> 1. Visually check the wiring harness connection. 2. Replace the harness if it has visible damage. 3. Replace the LH side air bag (Satellite) sensor. 4. Replace the air bag diagnosis sensor unit. 5. Replace the related harness.

WHIA0204E

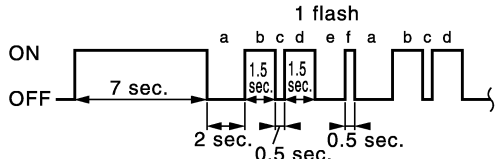
<Front RH side air bag module>	
Flash pattern	Repair order
<p>a through f are repeated. f: One flash indicate malfunctioning front RH side air bag module circuit.</p> 	<ol style="list-style-type: none"> 1. Visually check the wiring harness connection. 2. Replace the harness if it has visible damage. 3. Replace front RH seat back assembly. 4. Replace the air bag diagnosis sensor unit. 5. Replace the related harness.

WHIA0264E

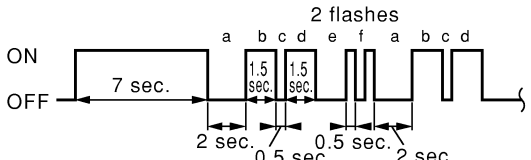
<Front LH side air bag module>	
Flash pattern	Repair order
<p>a through f are repeated. f: Two flashes indicate malfunctioning front LH side air bag module circuit.</p> 	<ol style="list-style-type: none"> 1. Visually check the wiring harness connection. 2. Replace the harness if it has visible damage. 3. Replace front LH seat back assembly. 4. Replace the air bag diagnosis sensor unit. 5. Replace the related harness.

WHIA0265E

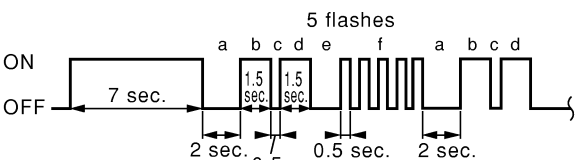
<RH side curtain air bag module>	
Flash pattern	Repair order
<p>a through f are repeated. f: Five flashes indicate malfunctioning RH side curtain air bag module circuit.</p> 	<ol style="list-style-type: none"> 1. Visually check the wiring harness connection. 2. Replace the harness if it has visible damage. 3. Replace RH side curtain air bag module. 4. Replace the air bag diagnosis sensor unit. 5. Replace the related harness.

WHIA0266E

A
B
C
D
E
F
G
I
J
K
L
M

SRS

TROUBLE DIAGNOSIS

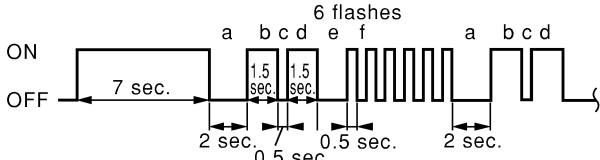
<LH side curtain air bag module>	
Flash pattern	Repair order
<p>a through f are repeated. f: Six flashes indicate malfunctioning LH side curtain air bag module circuit.</p> 	<ol style="list-style-type: none"> 1. Visually check the wiring harness connection. 2. Replace the harness if it has visible damage. 3. Replace LH side curtain air bag module. 4. Replace the air bag diagnosis sensor unit. 5. Replace the related harness.

WHIA0267E

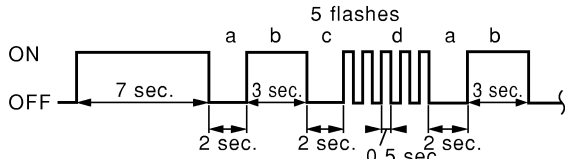
<Occupant classification system>	
Flash pattern	Repair order
<p>a through d are repeated. d: Five flashes indicate malfunctioning occupant classification system control unit.</p> 	<ol style="list-style-type: none"> 1. Visually check the wiring harness connection. 2. Replace the harness if it has visible damage. 3. Replace the RH front seat cushion occupant classification system control unit assembly. 4. Replace the air bag diagnosis sensor unit.

WHIA0211E

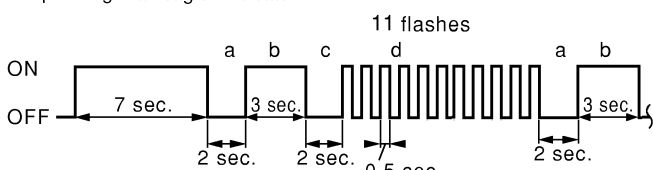
<Front passenger air bag off indicator>	
Flash pattern	Repair order
<p>a through d are repeated. d: Eleven flashes indicate malfunctioning front passenger air bag off indicator.</p> 	<ol style="list-style-type: none"> 1. Visually check the wiring harness connection. 2. Replace the harness if it has visible damage. 3. Replace front passenger air bag off indicator. 4. Replace the air bag diagnosis sensor unit. 5. Replace the related harness.

WHIA0212E

TROUBLE DIAGNOSIS

EHS001V6

Trouble Diagnosis: "AIR BAG" Warning Lamp Does Not Turn Off DIAGNOSTIC PROCEDURE 7

1. CHECK CONDITION OF AIR BAG MODULE

Inspect for any deployed air bag modules or seat belt pre-tensioners.

Are any air bag modules or seat belt pre-tensioners deployed?

- Yes >> Refer to [SRS-54, "COLLISION DIAGNOSIS"](#) .
- No >> GO TO 2.

2. CHECK THE AIR BAG FUSE

Check 10A fuse [No. 1, located in the fuse block (J/B)].

Refer to [PG-4, "POWER SUPPLY ROUTING CIRCUIT"](#) .

OK or NG

- OK >> GO TO 4.
- NG >> GO TO 3.

3. CHECK AIR BAG FUSE AGAIN

Replace 10A fuse [No. 1, located in the fuse block (J/B)] and turn ignition switch ON.

Does the fuse blow again?

- Yes >> Repair harness.
- No >> Inspection End.

4. CHECK AIR BAG DIAGNOSIS SENSOR UNIT



Connect CONSULT-II and touch "START".

Is "AIR BAG" displayed on CONSULT-II?

- Yes >> GO TO 5.
- No >> Visually inspect the air bag diagnosis sensor unit harness connections. If the connections are OK, replace the air bag diagnosis sensor unit. Refer to [SRS-52, "Removal and Installation"](#) .

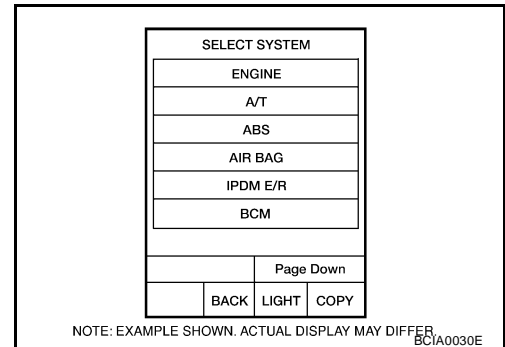

5. CHECK HARNESS CONNECTION

Check for loose connections between the combination meter and the air bag diagnosis sensor unit.

OK or NG

- OK >> Replace air bag diagnosis sensor unit. Refer to [SRS-52, "Removal and Installation"](#) .
- NG >> Properly connect the combination meter and air bag diagnosis sensor unit harness connectors. If "AIR BAG" warning lamp still does not turn off, replace the wiring harness.

TROUBLE DIAGNOSIS

EHS001V7

Trouble Diagnosis: "AIR BAG" Warning Lamp Does Not Turn On DIAGNOSTIC PROCEDURE 8

1. CHECK METER FUSE

Check the 10A fuse [No. 13, located in the fuse block (J/B)] .
Refer to [PG-4, "POWER SUPPLY ROUTING CIRCUIT"](#) .

OK or NG

OK >> GO TO 3.
NG >> GO TO 2.

2. REPLACE METER FUSE AND CHECK AGAIN

Replace 10A fuse [No. 13, located in the fuse block (J/B)] and turn ignition switch ON.

Does the fuse blow again?

Yes >> Replace harness.
No >> Inspection End.

3. CHECK HARNESS CONNECTIONS BETWEEN AIR BAG DIAGNOSIS SENSOR UNIT AND COMBINATION METER

Inspect the harness and connectors between the air bag diagnosis sensor unit and the combination meter.

Do the harness or connectors have any visible damage?

Yes >> Replace harness.
No >> GO TO 4.

4. CHECK COMBINATION METER

Disconnect the air bag diagnosis sensor unit harness connectors and turn ignition switch ON.

Does "AIR BAG" warning lamp turn on?

Yes >> Replace the air bag diagnosis sensor unit. Refer to [SRS-52, "Removal and Installation"](#) .
No >> Replace the combination meter. Refer to [IP-19, "COMBINATION METER"](#) .

DRIVER AIR BAG MODULE

PFP:K8510

DRIVER AIR BAG MODULE

Removal and Installation

EHS001UD

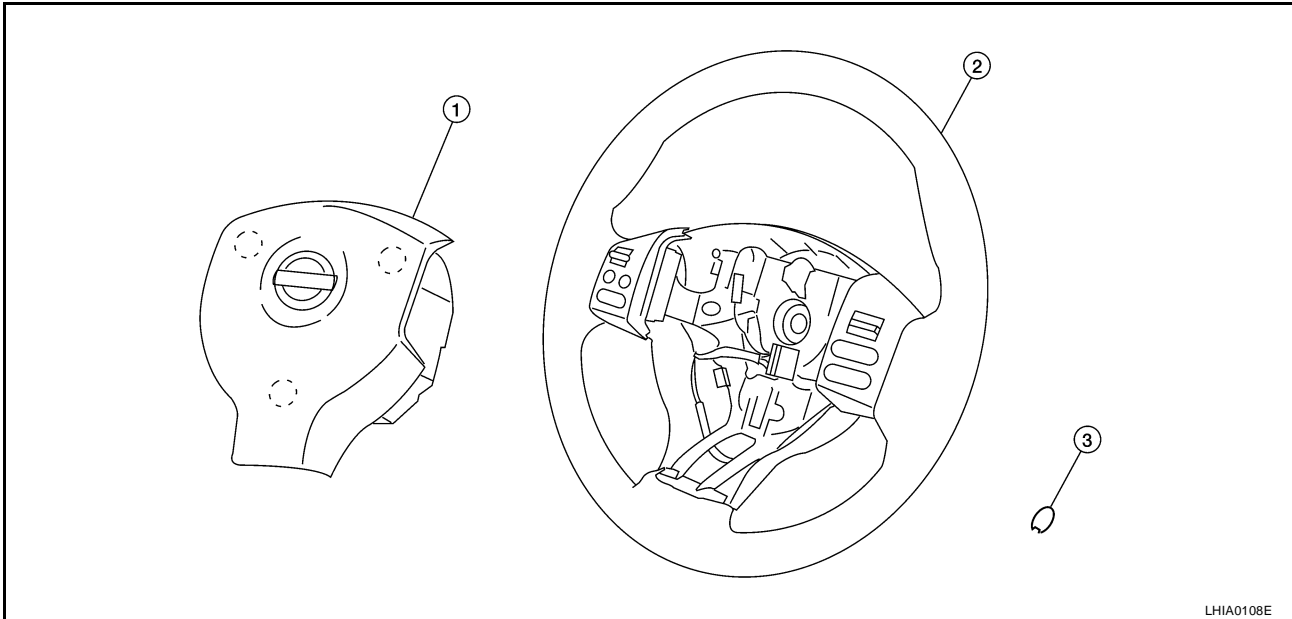

LHIA0108E

1. Driver air bag module

2. Steering wheel

3. Cover

○ Pawl

A
B
C
D
E
F
G

SRS

REMOVAL

WARNING:

- When servicing the SRS, do not work from directly in front of air bag module.
- Always place air bag module with pad side facing upward.

CAUTION:

- Before servicing the SRS, turn ignition switch OFF, disconnect both battery cables, then wait at least 3 minutes.
- Do not attempt to repair or replace damaged direct-connect SRS component connectors. If a driver air bag direct-connect harness connector is damaged, the spiral cable must be replaced.
- Do not insert any foreign objects (screwdriver, etc.) into air bag module or harness connectors.
- Do not disassemble air bag module.
- Do not expose the air bag module to temperatures exceeding 90°C (194°F).
- Replace the air bag module if it has been dropped or sustained an impact.
- Do not allow oil, grease or water to come in contact with the air bag module.

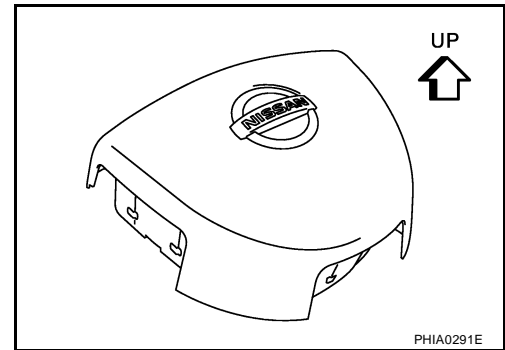

PHIA0291E

I
J
K
L
M



WHIA0321E

1. Disconnect the negative and positive battery cables, then wait at least 3 minutes.
2. Remove the covers RH/LH.

DRIVER AIR BAG MODULE

3. Place the steering wheel in the straight ahead position.
4. Release the driver air bag module retaining clips RH/LH.
 - Insert suitable 4mm - 6mm blunt tool (A) through LH access hole on back side of steering wheel (1) and contact retaining clip.

CAUTION:

Do not use sharp edged objects such as screwdrivers to release driver air bag module from steering wheel, SRS components may be unintentionally damaged.

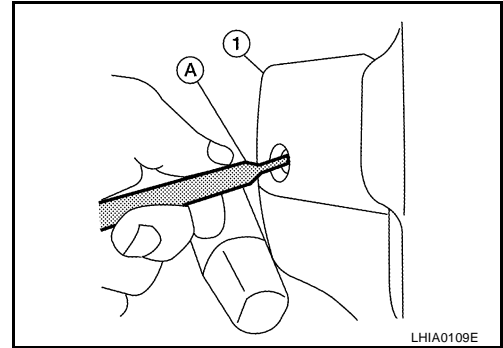

- Press tool inward with sufficient force on retaining clip (1) to release LH pawl of driver air bag module from steering wheel.
- Repeat for RH pawl of driver air bag module from steering wheel.
- Tilt top edge away from steering wheel, then lift upward releasing lower pawl of driver air bag module from steering wheel.

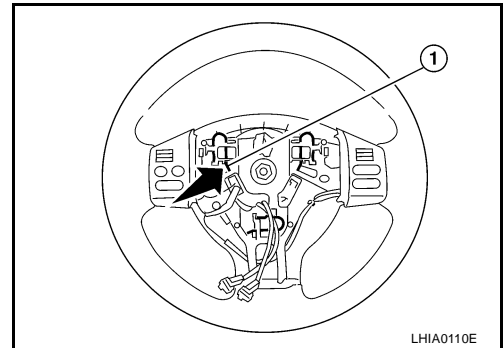

5. Disconnect driver air bag module connectors (1) and horn connector (2).

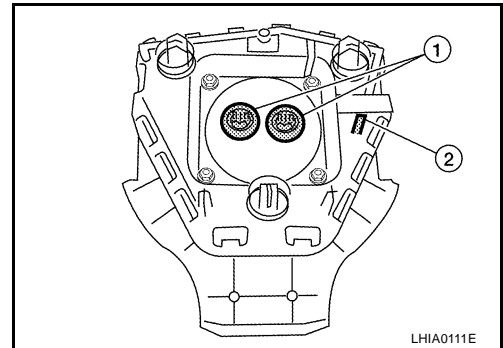

- For removal/installation of the direct-connect SRS connectors, refer to [SRS-8, "Direct-connect SRS Component Connectors"](#) .

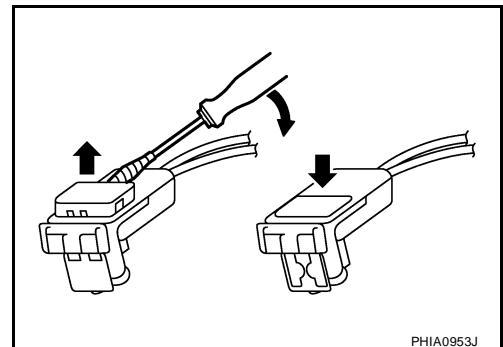

INSTALLATION

Installation is in the reverse order of removal.

- For removal/installation of the direct-connect SRS connectors, refer to [SRS-8, "Direct-connect SRS Component Connectors"](#) .
- If driver air bag module is being replaced due to deployment, spiral cable must also be replaced. Refer to [SRS-44, "SPIRAL CABLE"](#) .
- After the work is completed, perform self-diagnosis to check that no malfunction is detected. Refer to [SRS-21, "SRS Operation Check"](#) .

DRIVER AIR BAG MODULE

CAUTION:

- Make sure driver air bag module harness (1) is routed properly to avoid SRS component damage during installation.

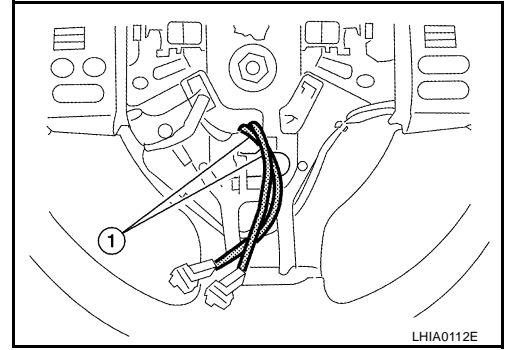

A
B
C
D
E
F
G
I
J
K
L
M

SRS

SPIRAL CABLE

PFP:25554

SPIRAL CABLE

Removal and Installation

EHS001UE

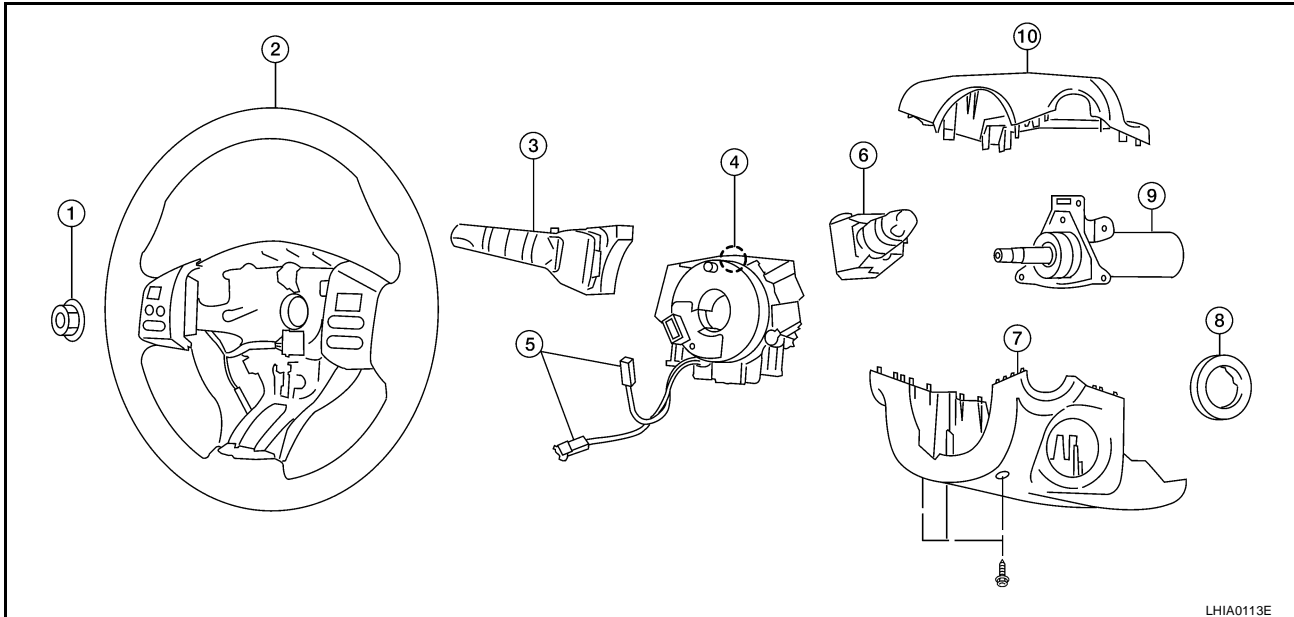

- | | | |
|---|-------------------------------------|------------------------------------|
| 1. Nut, refer to PS-6, "STEERING WHEEL" | 2. Steering wheel | 3. Lighting and turn signal switch |
| 4. Spiral cable | 5. Driver air bag module connectors | 6. Wiper and washer switch |
| 7. Column cover lower | 8. Steering lock escutcheon | 9. Steering column assembly |
| 10. Column cover upper | ○ Pawl | |

REMOVAL

WARNING:

When servicing the SRS, do not work from directly in front of air bag module.

CAUTION:

- Before servicing the SRS, turn ignition switch OFF, disconnect both battery cables and wait at least 3 minutes.
 - Do not tap or bump the steering wheel.
 - Do not disassemble the spiral cable.
 - Do not allow oil, grease or water to come in contact with the spiral cable.
 - Replace the spiral cable if it has been dropped or sustained an impact.
 - With the steering linkage disconnected, the spiral cable may snap by turning the steering wheel beyond the limited number of turns. The spiral cable can be turned counterclockwise about 2.5 turns from the neutral position.
1. Disconnect the negative and positive battery cables, then wait at least 3 minutes.
 2. Set the front wheels to the straight-ahead/neutral position.
 3. Remove the steering wheel. Refer to [PS-6, "STEERING WHEEL"](#).
 4. Remove the column cover upper and lower.

SPIRAL CABLE

5. Disconnect wiper and washer switch connector (1). Then while pressing tabs (2), pull wiper and washer switch away from spiral cable to remove.

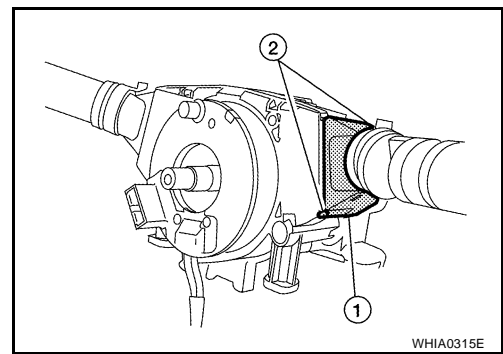

6. Disconnect lighting and turn signal switch connector (1). Then while pressing tabs (2), pull lighting and turn signal switch toward driver door to remove.
7. Remove the screws, then release the tab at the top and pull the spiral cable away from the steering column assembly.
8. Disconnect spiral cable connectors.

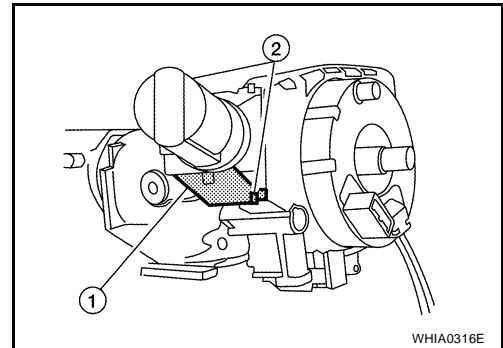

INSTALLATION

Installation is in the reverse order of removal.

- Align spiral cable correctly when installing steering wheel, refer to [PS-6, "STEERING WHEEL"](#) . Make sure spiral cable alignment and centering marks (B) are matched and in the neutral position. The neutral position is detected by turning left 2.6 revolutions from the right end position, ending with the locating pin (A) at the top. Place steering wheel in straight ahead position, then install it with the locating pin hole (C) directly over spiral cable locating pin.
- After the work is completed, perform self-diagnosis to make sure no malfunction is detected. Refer to [SRS-21, "SRS Operation Check"](#) .

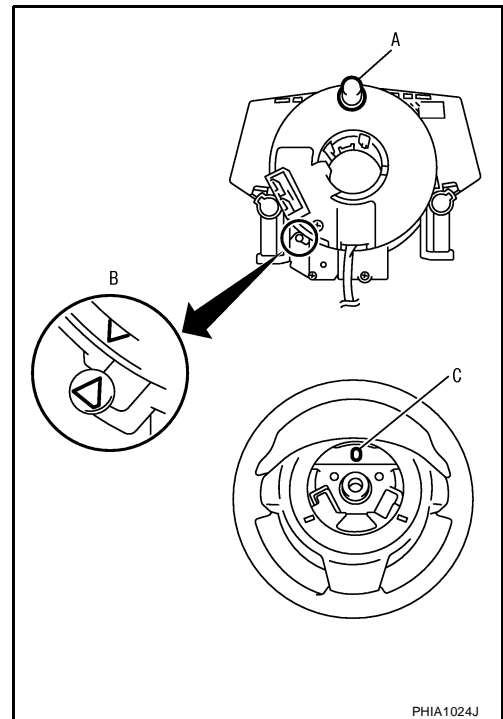

FRONT PASSENGER AIR BAG MODULE

PPF:K8515

FRONT PASSENGER AIR BAG MODULE

Removal and Installation REMOVAL

EHS001UF

WARNING:

- When servicing the SRS, do not work from directly in front of air bag module.
- Always place front passenger air bag module with pad side facing upward.

CAUTION:

- Before servicing SRS, turn the ignition switch OFF, disconnect both battery cables and wait at least 3 minutes.
- Do not use old bolts after removal; replace with new bolts.
- Do not insert any foreign objects (screwdriver, etc.) into air bag module or harness connectors.
- Do not disassemble air bag module.
- Do not expose the front passenger air bag module to temperatures exceeding 90°C (194°F).
- Replace the front passenger air bag module if it has been dropped or sustained an impact.
- Do not allow oil, grease or water to come in contact with the front passenger air bag module.



1. Disconnect the negative and positive battery cables, then wait at least 3 minutes.
2. Remove the side ventilator assembly (right). Refer to [IP-10, "INSTRUMENT PANEL ASSEMBLY"](#).
3. Disconnect front passenger air bag module connector (1) and remove the upper instrument panel assembly bolts (2).
←: Vehicle front
4. Remove the front passenger air bag module bolts (3) from the steering member.

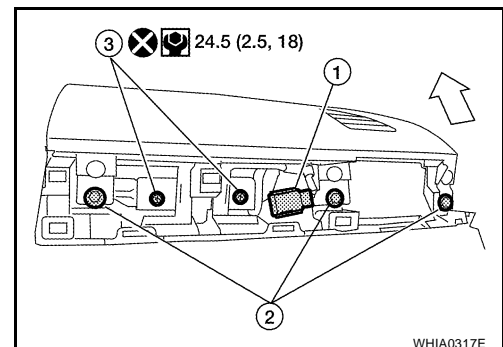

5. Release the pawls and remove the front passenger air bag module (1) from the upper instrument panel assembly (2).

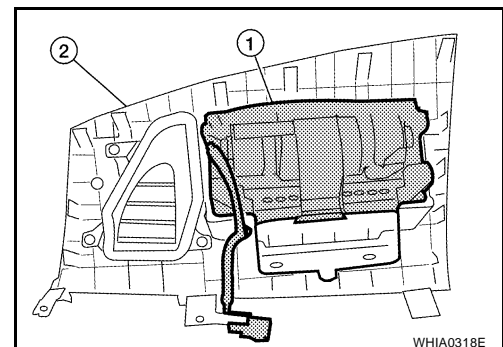

INSALLATION

Installation is in the reverse order of removal.

- After the work is completed, perform self-diagnosis to check that no malfunction is detected. Refer to [SRS-21, "SRS Operation Check"](#).

SIDE CURTAIN AIR BAG MODULE

SIDE CURTAIN AIR BAG MODULE

PF9:985P0

Components

EHS0027H

Hatchback Models

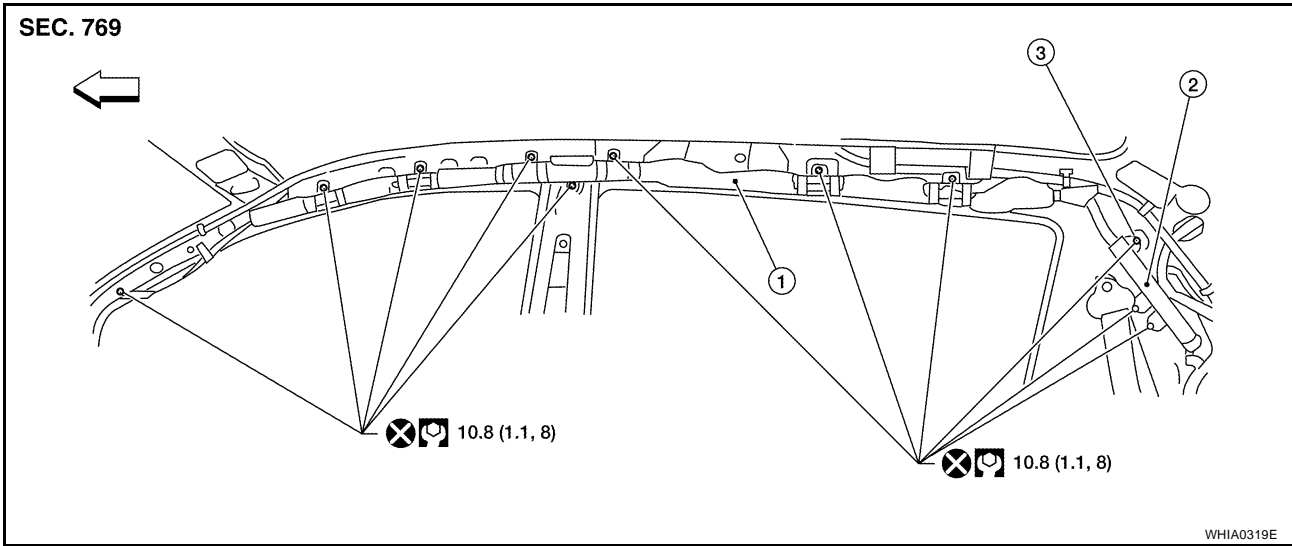

- 1. Side curtain air bag module
 - 2. Inflator
 - 3. Ground bolt
- ← Vehicle front

Sedan Models

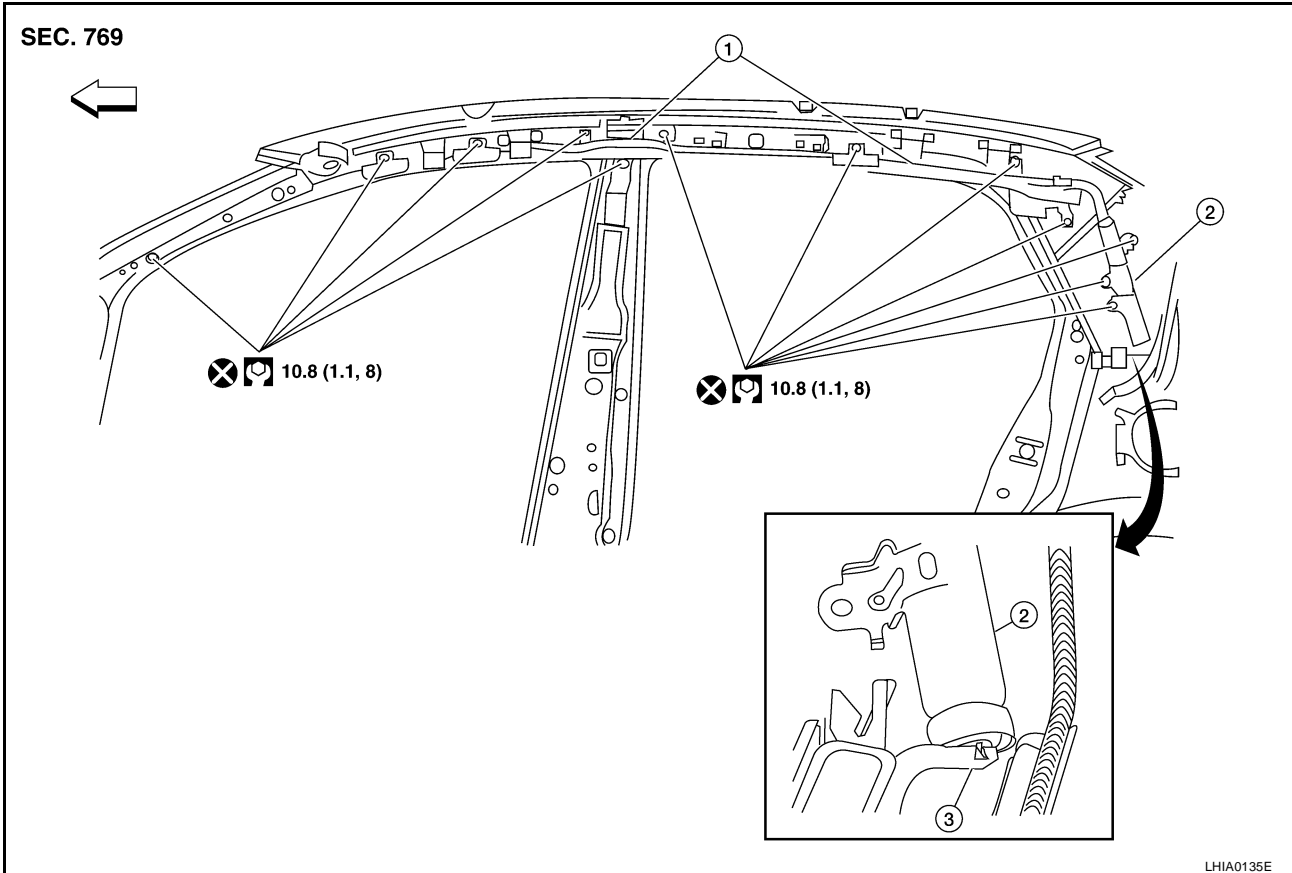

- 1. Side curtain air bag module
 - 2. Inflator
 - 3. Side air bag module connector
- ← Vehicle front

A
B
C
D
E
F
G
I
J
K
L
M

SRS

SIDE CURTAIN AIR BAG MODULE

EHS001UG

Removal and Installation

REMOVAL

WARNING:

- When servicing the SRS, do not work from directly in front of air bag module.
- Always place the curtain air bag module with deployment side facing upward.
- Do not reuse center pillar upper garnish if removed.

CAUTION:

- Before servicing SRS, turn the ignition switch OFF, disconnect both battery cables and wait at least 3 minutes.
- Do not use old bolts after removal; replace with new bolts.
- Do not insert any foreign objects (screwdriver, etc.) into air bag module or harness connectors.
- Do not disassemble air bag module.
- Do not expose the side curtain air bag module to temperatures exceeding 90°C (194°F).
- Replace the side curtain air bag module if it has been dropped or sustained an impact.
- Do not allow oil, grease or water to come in contact with the side curtain air bag module.
- Do not attempt to repair or replace damaged direct-connect SRS component connectors. If a direct-connect harness connector is damaged, the harness must be replaced.



1. Disconnect both the negative and positive battery cables, then wait at least 3 minutes.
2. Remove the headlining. Refer to [EI-46, "HEADLINING"](#).
3. Disconnect side curtain air bag module connector.

NOTE:

For removal/installation of the direct-connect SRS connectors, refer to [SRS-8, "Direct-connect SRS Component Connectors"](#).

4. Remove the bolts in order starting at the rear, then remove the side curtain air bag module.

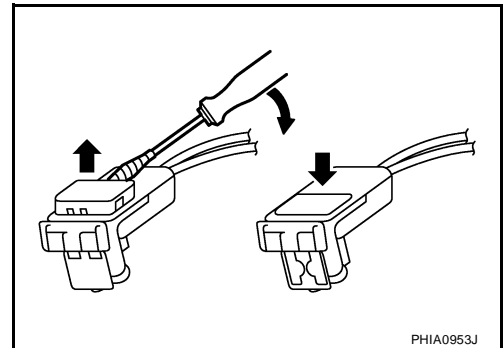

INSTALLATION

Installation is in the reverse order of removal.

- For removal/installation of the direct-connect SRS connectors, refer to [SRS-8, "Direct-connect SRS Component Connectors"](#).
- After replacement of side curtain air bag module, perform self-diagnosis to check that no malfunction is detected. Refer to [SRS-21, "SRS Operation Check"](#).

CRASH ZONE SENSOR

PFP:98531

CRASH ZONE SENSOR

Removal and Installation REMOVAL

EHS001UH

CAUTION:

- Before servicing the SRS, turn ignition switch OFF, disconnect both battery cables and wait at least 3 minutes.
- Do not disassemble the crash zone sensor.
- Do not use old nuts after removal; replace with new nuts.
- Replace the crash zone sensor if it has been dropped or sustained an impact.
- Check crash zone sensor to make sure it is free of deformities, dents, cracks or rust. If it shows any visible signs of damage, replace it with a new one.



1. Disconnect both the negative and positive battery cables, then wait at least 3 minutes.
2. Remove upper radiator cover and front grille, refer to [EI-21, "FRONT GRILLE"](#) .
3. Disconnect crash zone sensor harness connector (1).
4. Remove the nuts (2) and remove the crash zone sensor (3).

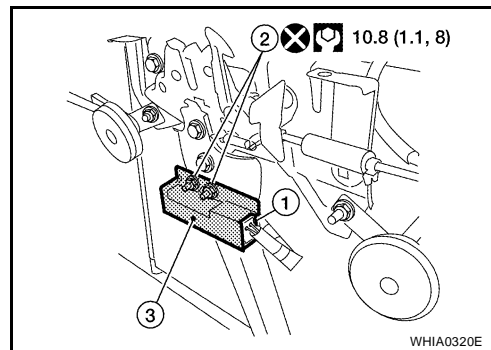

INSTALLATION

Installation is in the reverse order of removal.

- After the work is completed, perform self-diagnosis to check that no malfunction is detected. Refer to [SRS-21, "SRS Operation Check"](#) .

SIDE AIR BAG (SATELLITE) SENSOR

PF9:98830

EHS001UI

SIDE AIR BAG (SATELLITE) SENSOR

Removal and Installation REMOVAL

WARNING:

Do not reuse center pillar upper garnish if removed.

CAUTION:

- Before servicing the SRS, turn ignition switch OFF, disconnect both battery cables and wait at least 3 minutes.
- Do not disassemble the side air bag (satellite) sensor.
- Do not use old nuts after removal; replace with new nuts.
- Replace the side air bag (satellite) sensor if it has been dropped or sustained an impact.
- Check side air bag (satellite) sensor to make sure it is free of deformities, dents, cracks or rust. If it shows any visible signs of damage, replace it with a new one.



1. Disconnect both the negative and positive battery cables, then wait at least 3 minutes.
2. Remove the front seat belt retractor. Refer to [SB-3, "Removal and Installation of Front Seat Belt"](#) .
3. Remove the nuts (1) and remove side air bag (satellite) sensor (2).
⇐: Vehicle front
4. Disconnect the side air bag (satellite) sensor harness connector (3).

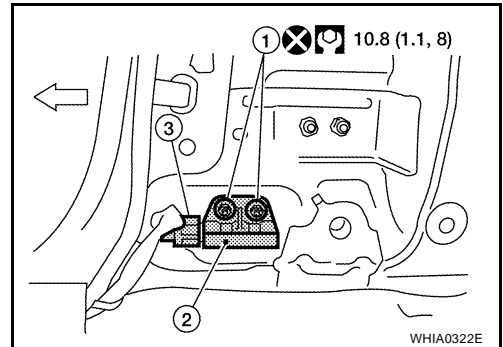

INSTALLATION

Installation is in the reverse order of removal.

- After the work is completed, perform self-diagnosis to make sure no malfunction is detected. Refer to [SRS-21, "SRS Operation Check"](#) .

FRONT SEAT BELT PRE-TENSIONER

FRONT SEAT BELT PRE-TENSIONER

PFP:86884

Removal and Installation

EHS001UJ

For removal and installation procedures, refer to [SB-3, "Removal and Installation of Front Seat Belt"](#) .

A

B

C

D

E

F

G

SRS

I

J

K

L

M

DIAGNOSIS SENSOR UNIT

PFP:28556

EHS001UK

DIAGNOSIS SENSOR UNIT

Removal and Installation REMOVAL

WARNING:

Before disconnecting diagnosis sensor unit harness connector(s), be sure to disconnect harness connectors from air bag modules and front seat belt pre-tensioner to prevent deployment by static electricity.

CAUTION:

- Before servicing the SRS, turn the ignition switch OFF, disconnect both battery cables and wait at least 3 minutes.
- Do not disassemble diagnosis sensor unit.
- Do not use old bolts; replace with new bolts.
- Replace the diagnosis sensor unit if it has been dropped or sustained an impact.
- Check diagnosis sensor unit bracket to make sure it is free of deformities, dents, cracks or rust. If it shows any visible signs of damage, replace with new one.
- The diagnosis sensor unit must always be installed with the arrow mark "←" pointing toward the front of the vehicle for proper operation.

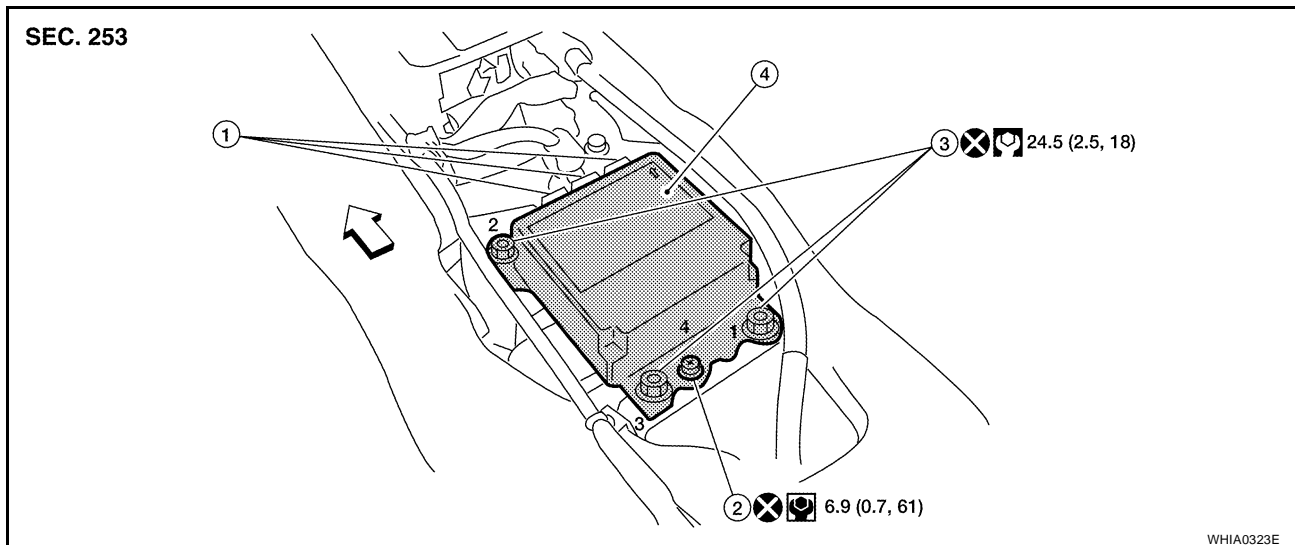

- | | | |
|-------------------------------------|-----------------|---------|
| 1. Diagnosis sensor unit connectors | 2. Ground Bolt | 3. Bolt |
| 4. Diagnosis sensor unit | ← Vehicle front | |

1. Disconnect the negative and positive battery cables, then wait at least 3 minutes.
2. Disconnect the harness connectors for each air bag module and seat belt pre-tensioner. Refer to [SRS-41, "DRIVER AIR BAG MODULE"](#) , [SRS-46, "FRONT PASSENGER AIR BAG MODULE"](#) , [SRS-47, "SIDE CURTAIN AIR BAG MODULE"](#) , [SRS-51, "FRONT SEAT BELT PRE-TENSIONER"](#) .
3. Remove center console assembly. Refer to [IP-10, "INSTRUMENT PANEL ASSEMBLY"](#) .
4. Disconnect diagnosis sensor unit connectors.
5. Remove the bolts and the ground bolt, then remove the diagnosis sensor unit.

INSTALLATION

Installation is in the reverse order of removal.

- The diagnosis sensor unit must always be installed with the arrow mark "←" pointing toward the front of the vehicle.
- Follow the tightening sequence 1,2,3,4 as shown.
- After the work is completed, perform self-diagnosis to check that no malfunction is detected. Refer to [SRS-21, "SRS Operation Check"](#) .

ECU DISCRIMINATED NO.

After replacing the diagnosis sensor unit, confirm that the diagnosis sensor unit identification is correct for the vehicle as equipped. Refer to [SRS-19, "CONSULT-II Function \(AIR BAG\)"](#) .

OCCUPANT CLASSIFICATION SYSTEM CONTROL UNIT

OCCUPANT CLASSIFICATION SYSTEM CONTROL UNIT

PFP:98852

Removal and Installation

EHS001VA

The occupant classification system control unit, occupant classification system sensor, and bladder are an integral part of the front passenger seat cushion and are replaced as an assembly. Refer to [SE-10, "FRONT SEAT"](#) to remove the seat, and [SE-12, "SEAT CUSHION TRIM AND PAD"](#) to replace the seat cushion.

A
B
C
D
E
F
G
I
J
K
L
M

SRS

COLLISION DIAGNOSIS

PFP:00015

EHS001VB

COLLISION DIAGNOSIS

For Frontal Collision

Check the SRS components using the following table.

- After the work is completed, perform self-diagnosis to check that no malfunction is detected. Refer to [SRS-21, "SRS Operation Check"](#).

SRS INSPECTION (FOR FRONTAL COLLISION)

Part	SRS is activated	SRS is NOT activated
Driver air bag module	If the driver air bag has deployed: REPLACE Install with new fasteners.	If the driver air bag has NOT been activated: 1. Remove driver air bag module. Check harness cover and connectors for damage, terminals for deformities, and harness for binding. 2. Install driver air bag module into the steering wheel to check fit and alignment with the wheel. 3. If no damage is found, reinstall with new fasteners. 4. If damaged— REPLACE . Install driver air bag modules with new fasteners.
Front passenger air bag module	If the front passenger air bag has deployed: REPLACE Install with new fasteners.	If the front passenger air bag has NOT been activated: 1. Remove front passenger air bag module. Check harness cover and connectors for damage, terminals for deformities, and harness for binding. 2. Install front passenger air bag module into the instrument panel to check fit with the instrument panel. 3. If no damage is found, reinstall with new fasteners. 4. If damaged— REPLACE . Install front passenger air bag modules with new fasteners.
Crash zone sensor	If any of the front air bags or seat belt pre-tensioners* have been activated: REPLACE the crash zone sensor and bracket with new fasteners. *: Confirm seat belt pre-tensioner activation using CONSULT-II only.	If the front air bags or seat belt pre-tensioners have NOT been activated: 1. Remove the crash zone sensor. Check harness connectors for damage, terminals for deformities, and harness for binding. 2. Check for visible signs of damage (dents, cracks, deformation) of the crash zone sensor and bracket. 3. Install the crash zone sensor to check fit. 4. If no damage is found, reinstall with new fasteners. 5. If damaged— REPLACE the crash zone sensor and bracket with new fasteners.
Seat belt pre-tensioner assemblies (All applicable locations: buckle, reel, lap outer)	If either the driver or passenger seat belt pre-tensioner* has been activated: REPLACE all seat belt pre-tensioner assemblies with new fasteners. *: Confirm seat belt pre-tensioner activation using CONSULT-II only.	If the pre-tensioners have NOT been activated: 1. Remove seat belt pre-tensioners. Check harness cover and connectors for damage, terminals for deformities, and harness for binding. 2. Check belts for damage and anchors for loose mounting. 3. Check retractor for smooth operation. 4. Check seat belt adjuster for damage. 5. Check for deformities of the center pillar inner. 6. If the center pillar inner has no damage, REPLACE the seat belt pre-tensioner assembly. 7. If no damage is found, reinstall seat belt pre-tensioner assembly. 8. If damaged— REPLACE . Install the seat belt pre-tensioners with new fasteners.
Diagnosis sensor unit	If any of the SRS components have been activated: REPLACE the diagnosis sensor unit. Install with new fasteners.	If none of the SRS components have been activated: 1. Check case for dents, cracks or deformities. 2. Check connectors for damage, and terminals for deformities. 3. If no damage is found, reinstall with new fasteners. 4. If damaged— REPLACE . Install diagnosis sensor unit with new fasteners.

COLLISION DIAGNOSIS

Part	SRS is activated	SRS is NOT activated
Steering wheel	<ol style="list-style-type: none"> 1. Visually check steering wheel for deformities. 2. Check harness (built into steering wheel) and connectors for damage, and terminals for deformities. 3. Install driver air bag module into the steering wheel to check fit and alignment with the wheel. 4. Check steering wheel for excessive free play. 5. If no damage is found, reinstall. 6. If damaged—REPLACE. 	
Spiral cable	If the driver front air bag has deployed: REPLACE the spiral cable.	If the driver front air bag has not deployed: <ol style="list-style-type: none"> 1. Visually check spiral cable and combination switch for damage. 2. Check connectors and protective tape for damage. 3. Check steering wheel for noise, binding or heavy operation. 4. If no damage is found, reinstall. 5. If damaged—REPLACE.
Occupant classification system (Passenger seat)	<ol style="list-style-type: none"> 1. Remove passenger seat. 2. Check control unit case for dents, cracks or deformities. 3. Check connectors and pressure sensor tube for damage, and terminals for deformities. 4. Check seat frame and cushion pan for dents or deformities. 5. If no damage is found, reinstall seat with new fasteners. 6. If damaged — REPLACE seat cushion assembly with new fasteners. 	
Harness and connectors	<ol style="list-style-type: none"> 1. Check connectors for poor connection, damage, and terminals for deformities. 2. Check harness for binding, chafing, cuts, or deformities. 3. If no damage is found, reinstall the harness and connectors. 4. If damaged—REPLACE the damaged harness. Do not attempt to repair, splice or modify any SRS harness. 	
Instrument panel	If the passenger front air bag has deployed: REPLACE the instrument panel assembly.	If the passenger front air bag has NOT deployed: <ol style="list-style-type: none"> 1. Visually check instrument panel for damage. 2. If no damage is found, reinstall the instrument panel. 3. If damaged—REPLACE the instrument panel.

A

B

C

D

E

F

G

SRS

I

J

For Side and Rollover Collision

EHS001VC

Check the SRS components using the following table.

- After the work is completed, perform self-diagnosis to check that no malfunction is detected. Refer to [SRS-21, "SRS Operation Check"](#) .

WHEN SRS IS ACTIVATED IN THE SIDE OR ROLLOVER COLLISION

1. Replace the following components:
 - Front seat back assembly (on the side on which side air bag is activated)
 - Diagnosis sensor unit
 - (LH or RH) side air bag (satellite) sensor (on the side on which side air bag is activated)
2. Check the SRS components and the related parts using the following table.
 - Replace any SRS components and the related parts showing visible signs of damage (dents, cracks, deformation).
3. Conduct self-diagnosis using CONSULT-II and "AIR BAG" warning lamp. Refer to [SRS-21, "SRS Operation Check"](#) for details. Ensure entire SRS operates properly.

WHEN SRS IS NOT ACTIVATED IN THE SIDE OR ROLLOVER COLLISION

1. Check the SRS components and the related parts using the following table.
 - If the front seat back assembly is damaged, the front seat back assembly must be replaced.
2. Conduct self-diagnosis using CONSULT-II and "AIR BAG" warning lamp. Refer to [SRS-21, "SRS Operation Check"](#) for details. Ensure entire SRS operates properly.

COLLISION DIAGNOSIS

SRS INSPECTION (FOR SIDE AND ROLLOVER COLLISION)

Part	SRS is activated	SRS is NOT activated
LH side curtain air bag module	If the LH side curtain air bag has deployed: REPLACE the LH side curtain air bag module. (Repair the center pillar inner, etc. before installing new one if damaged.)	If the LH side curtain air bag has NOT deployed: <ol style="list-style-type: none"> 1. Check for visible signs of damage (dents, tears, deformation) of the center pillar on the collision side. 2. If damaged—Remove the LH side curtain air bag module. 3. Check for visible signs of damaged (tears etc.) of the LH side curtain air bag module. 4. Check harness and connectors for damage, and terminals for deformities. 5. If no damage is found, reinstall the LH side curtain air bag module with new fasteners. 6. If damaged—REPLACE the LH side curtain air bag module with new fasteners.
RH side curtain air bag module	If the RH side curtain air bag has deployed: REPLACE the RH side curtain air bag module. (Repair the center pillar inner, etc. before installing new one if damaged.)	If the RH side curtain air bag has NOT deployed: <ol style="list-style-type: none"> 1. Check for visible signs of damage (dents, tears, deformation) of the center pillar on the collision side. 2. If damaged—Remove the RH side curtain air bag module. 3. Check for visible signs of damaged (tears etc.) of the RH side curtain air bag module. 4. Check harness and connectors for damage, and terminals for deformities. 5. If no damage is found, reinstall the RH side curtain air bag module with new fasteners. 6. If damaged—REPLACE the RH side curtain air bag module with new fasteners.
Front LH side air bag module	If the front LH side air bag has deployed: REPLACE front LH seatback assembly.	If the front LH side air bag has NOT deployed: <ol style="list-style-type: none"> 1. Check for visible signs of damage (dents, tears, deformation) of the seat back on the collision side. 2. Check harness and connectors for damage, and terminals for deformities. 3. If damaged—REPLACE the front LH seatback assembly.
Front RH side air bag module	If the front RH side air bag has deployed: REPLACE front RH seatback assembly.	If the front RH side air bag has NOT deployed: <ol style="list-style-type: none"> 1. Check for visible signs of damage (dents, tears, deformation) of the seat back on the collision side. 2. Check harness and connectors for damage, and terminals for deformities. 3. If damaged—REPLACE the front RH seatback assembly.
(LH or RH) side air bag (satellite) sensor	If any of the SRS components have deployed: REPLACE the side air bag (satellite) sensor on the collision side with new fasteners. (Repair the center pillar inner, etc. before installing new one if damaged.)	If none of the SRS components have been activated: <ol style="list-style-type: none"> 1. Remove the side air bag (satellite) sensor on the collision side. Check harness connectors for damage, terminals for deformities, and harness for binding. 2. Check for visible signs of damage (dents, cracks, deformation) of the side air bag (satellite) sensor. 3. Install the side air bag (satellite) sensor to check fit. 4. If no damage is found, reinstall the side air bag (satellite) sensor with new fasteners. 5. If damaged—REPLACE the side air bag (satellite) sensor with new fasteners.
Diagnosis sensor unit	If any of the SRS components have deployed: REPLACE the diagnosis sensor unit with new fasteners.	If none of the SRS components have been activated: <ol style="list-style-type: none"> 1. Check case and bracket for dents, cracks or deformities. 2. Check connectors for damage, and terminals for deformities. 3. If no damage is found, reinstall the diagnosis sensor unit with new fasteners. 4. If damaged—REPLACE the diagnosis sensor unit with new fasteners.

COLLISION DIAGNOSIS

Part	SRS is activated	SRS is NOT activated	
Seat belt pre-tensioner assemblies (All applicable locations: buckle, reel, lap outer)	If either the driver or passenger seat belt pre-tensioner* has been activated: REPLACE all seat belt pre-tensioner assemblies with new fasteners. *: Confirm seat belt pre-tensioner activation using CONSULT-II only.	If the pre-tensioners have NOT been activated: 1. Remove seat belt pre-tensioners. Check harness cover and connectors for damage, terminals for deformities, and harness for binding. 2. Check belts for damage and anchors for loose mounting. 3. Check retractor for smooth operation. 4. Check seat belt adjuster for damage. 5. Check for deformities of the center pillar inner. 6. If the center pillar inner has no damage, REPLACE the seat belt pre-tensioner assembly. 7. If no damage is found, reinstall seat belt pre-tensioner assembly. 8. If damaged—REPLACE. Install the seat belt pre-tensioners with new fasteners.	A B C D
Seat (with front side air bag)	If either the front LH or front RH side air bag modules has been deployed: REPLACE front seat-back assembly on the deployed side.	If the front LH or front RH side air bag modules have NOT deployed: 1. Visually check the seat on the collision side. 2. Remove the seat on the collision side and check the following for damage and deformities. – Harness, connectors and terminals – Frame and recliner (for front and rear seat), and also adjuster and slides (for front seat) 3. If no damage is found, reinstall the seat. 4. If damaged—REPLACE the damaged seat parts using new fasteners. If the front seat back is damaged, the front seat back assembly must be replaced.	E F G
Center inner pillar	1. Check the center inner pillar on the collision side for damage (dents, cracks, deformation). 2. If damaged—REPAIR the center inner pillar.		SRS
Trim/headlining	1. Check for visible signs of damage (dents, cracks, deformation) of the interior trim on the collision side. 2. If damaged—REPLACE the damaged trim parts.		I

A
B
C
D
E
F
G
I
J
K
L
M

COLLISION DIAGNOSIS
