

WT
SECTION
ROAD WHEELS & TIRES

A
B
C
D

WT

CONTENTS

<p>PRECAUTIONS 2</p> <p style="padding-left: 20px;">Precautions for Supplemental Restraint System (SRS) "AIR BAG" and "SEAT BELT PRE-TENSIONER" 2</p> <p>PREPARATION 3</p> <p style="padding-left: 20px;">Special Service Tool 3</p> <p style="padding-left: 20px;">Commercial Service Tools 3</p> <p>NOISE, VIBRATION AND HARSHNESS (NVH)</p> <p>TROUBLESHOOTING 4</p> <p style="padding-left: 20px;">NVH Troubleshooting Chart 4</p> <p>ROAD WHEEL 5</p> <p style="padding-left: 20px;">Inspection 5</p> <p style="padding-left: 40px;">ALUMINUM WHEEL 5</p> <p style="padding-left: 40px;">STEEL WHEEL 5</p> <p>ROAD WHEEL TIRE ASSEMBLY 6</p> <p style="padding-left: 20px;">Balancing Wheels 6</p> <p style="padding-left: 20px;">Rotation 6</p> <p>TIRE PRESSURE MONITORING SYSTEM 7</p> <p style="padding-left: 20px;">System Components 7</p> <p style="padding-left: 20px;">System Description 7</p> <p style="padding-left: 40px;">BODY CONTROL MODULE (BCM) 7</p> <p style="padding-left: 40px;">TRANSMITTER 8</p> <p style="padding-left: 40px;">REMOTE KEYLESS ENTRY RECEIVER 8</p> <p style="padding-left: 40px;">COMBINATION METER 8</p> <p>CAN COMMUNICATION 9</p> <p style="padding-left: 20px;">System Description 9</p> <p>TROUBLE DIAGNOSES 10</p> <p style="padding-left: 20px;">Wiring Diagram — T/WARN — 10</p> <p style="padding-left: 20px;">Terminals and Reference Values for BCM 11</p> <p style="padding-left: 20px;">ID Registration Procedure 11</p> <p style="padding-left: 40px;">ID REGISTRATION WITH TRANSMITTER ACTIVATION TOOL 11</p> <p style="padding-left: 40px;">ID REGISTRATION WITHOUT TRANSMITTER ACTIVATION TOOL 12</p> <p style="padding-left: 20px;">Transmitter Wake Up Operation 13</p> <p style="padding-left: 20px;">CONSULT-II Function (BCM) 14</p> <p style="padding-left: 20px;">How to Perform Trouble Diagnosis for Quick and</p>	<p style="padding-left: 20px;">Accurate Repair 15</p> <p style="padding-left: 20px;">INTRODUCTION 15</p> <p style="padding-left: 20px;">WORK FLOW 15</p> <p style="padding-left: 20px;">Preliminary Check 16</p> <p style="padding-left: 20px;">Self-Diagnosis 16</p> <p style="padding-left: 40px;">DESCRIPTION 16</p> <p style="padding-left: 40px;">FUNCTION 16</p> <p style="padding-left: 20px;">Flash Code/Symptom Chart 19</p> <p>TROUBLE DIAGNOSIS FOR SELF-DIAGNOSTIC ITEMS 20</p> <p style="padding-left: 20px;">Data From Transmitter Not Being Received 20</p> <p style="padding-left: 40px;">MALFUNCTION CODE NO. 21, 22, 23 OR 24 (DTC C1708, C1709, C1710 OR C1711) 20</p> <p style="padding-left: 20px;">Transmitter Malfunction 20</p> <p style="padding-left: 40px;">MALFUNCTION CODE NO. 31, 32, 33, 34, 41, 42, 43, 44, 45, 46, 47 OR 48 20</p> <p style="padding-left: 20px;">Transmitter Pressure Malfunction 21</p> <p style="padding-left: 40px;">MALFUNCTION CODE NO. 35, 36, 37 OR 38 ... 21</p> <p style="padding-left: 20px;">Vehicle Speed Signal 22</p> <p style="padding-left: 40px;">MALFUNCTION CODE NO. 52 (DTC C1729) ... 22</p> <p>TROUBLE DIAGNOSIS FOR SYMPTOMS 23</p> <p style="padding-left: 20px;">Low Tire Pressure Warning Lamp Does Not Come On When Ignition Switch Is Turned On. 23</p> <p style="padding-left: 20px;">Low Tire Pressure Warning Lamp Stays On When Ignition Switch Is Turned On 23</p> <p style="padding-left: 20px;">Low Tire Pressure Warning Lamp Flashes When Ignition Switch Is Turned On. 25</p> <p style="padding-left: 20px;">Hazard Warning Lamps Flash When Ignition Switch Is Turned On 26</p> <p style="padding-left: 20px;">ID Registration Cannot Be Completed 26</p> <p>REMOVAL AND INSTALLATION 27</p> <p style="padding-left: 20px;">Transmitter (Pressure Sensor) 27</p> <p style="padding-left: 40px;">REMOVAL 27</p> <p style="padding-left: 40px;">INSTALLATION 27</p> <p>SERVICE DATA AND SPECIFICATIONS (SDS) 29</p> <p style="padding-left: 20px;">Road Wheel 29</p> <p style="padding-left: 20px;">Tire 29</p>
---	--

F
G
H
I
J
K
L
M

PRECAUTIONS

PRECAUTIONS

PF0:00001

Precautions for Supplemental Restraint System (SRS) “AIR BAG” and “SEAT BELT PRE-TENSIONER”

EES002ES

The Supplemental Restraint System such as “AIR BAG” and “SEAT BELT PRE-TENSIONER”, used along with a front seat belt, helps to reduce the risk or severity of injury to the driver and front passenger for certain types of collision. This system includes seat belt switch inputs and dual stage front air bag modules. The SRS system uses the seat belt switches to determine the front air bag deployment, and may only deploy one front air bag, depending on the severity of a collision and whether the front occupants are belted or unbelted. Information necessary to service the system safely is included in the SRS and SB section of this Service Manual.

WARNING:

- **To avoid rendering the SRS inoperative, which could increase the risk of personal injury or death in the event of a collision which would result in air bag inflation, all maintenance must be performed by an authorized NISSAN/INFINITI dealer.**
- **Improper maintenance, including incorrect removal and installation of the SRS, can lead to personal injury caused by unintentional activation of the system. For removal of Spiral Cable and Air Bag Module, see the SRS section.**
- **Do not use electrical test equipment on any circuit related to the SRS unless instructed to in this Service Manual. SRS wiring harnesses can be identified by yellow and/or orange harnesses or harness connectors.**

PREPARATION

PREPARATION

PFP:00002

Special Service Tool

EES002ET

The actual shapes of Kent-Moore tools may differ from those of special service tools illustrated here.

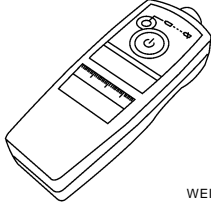
Tool number (Kent-Moore No.) Tool name	Description
KV991B1000 (J-45295) Transmitter activation tool	 WEIA0144E <ul style="list-style-type: none"> ● Transmitter wake up operation ● ID registration procedure

Commercial Service Tools

EES002EF

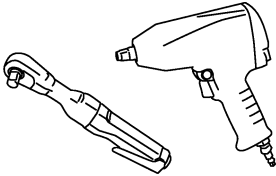
Tool name	Description
Power tool	 PBIC0190E <p>Removing wheel nuts</p>

NOISE, VIBRATION AND HARSHNESS (NVH) TROUBLESHOOTING

NOISE, VIBRATION AND HARSHNESS (NVH) TROUBLESHOOTING

PF0:00003

NVH Troubleshooting Chart

EES002D6

Use the chart below to help you find the cause of the symptom. If necessary, repair or replace these parts.

Symptom		Possible cause and SUSPECTED PARTS										Reference page						
		Improper installation, looseness	Out-of-round	Imbalance	Incorrect tire pressure	Uneven tire wear	Deformation or damage	Non-uniformity	Incorrect tire size	FRONT AXLE AND FRONT SUSPENSION	REAR AXLE AND REAR SUSPENSION	TIRES	ROAD WHEELS	DRIVE SHAFT	BRAKE	STEERING		
Noise	TIRES	×	×	×	×	×	×	×		×	×						FAX-5	
		×	×	×	×	×	×		×	×		×					WT-5	
					×				×	×	×							WT-6
		×	×	×	×	×	×	×	×	×	×							WT-29
	ROAD WHEEL	×	×	×	×	×	×		×	×	×		×					—
		×	×	×			×						×					—
		×	×	×			×						×					—
		×	×	×			×						×					—
																	FAX-4, "NVH Troubleshooting Chart", FSU-5, "NVH Troubleshooting Chart"	
																	RAX-3, "NVH Troubleshooting Chart", RSU-4, "NVH Troubleshooting Chart"	
																	Refer to TIRES in this chart	
																	Refer to ROAD WHEEL in this chart	
																	FAX-4, "NVH Troubleshooting Chart"	
																	BR-5, "NVH Troubleshooting Chart"	
																	PS-5, "NVH Trouble Shooting Chart"	

×: Applicable

ROAD WHEEL

PFP:40300

EES002D7

ROAD WHEEL

Inspection ALUMINUM WHEEL

1. Check tires for wear and improper inflation.
2. Check wheels for deformation, cracks and other damage. If deformed, remove wheel and check wheel runout.
 - a. Remove tire from aluminum wheel and mount on a tire balance machine.
 - b. Set dial indicator as shown.

Wheel runout : Refer to [WT-29, "Road Wheel"](#)
(Dial indicator value) .

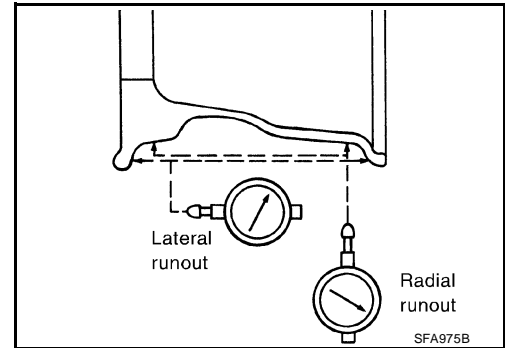

STEEL WHEEL

1. Check tires for wear and improper inflation.
2. Check wheels for deformation, cracks and other damage. If deformed, remove wheel and check wheel runout.
 - a. Remove tire from steel wheel and mount on a tire balance machine.
 - b. Set two dial indicators as shown.
 - c. Set each dial indicator to 0.
 - d. Rotate wheel and check dial indicators at several points around the circumference of the wheel.
 - e. Calculate runout at each point as shown.

$$\text{Radial runout} = (A+B)/2$$

$$\text{Lateral runout} = (C+D)/2$$

- f. Select maximum positive runout value and the maximum negative value. Add the two values to determine total runout. In case a positive or negative value is not available, use the maximum value (negative or positive) for total runout. If the total runout value exceeds the limit, replace steel wheel.

Wheel runout : Refer to [WT-29, "Road Wheel"](#) .

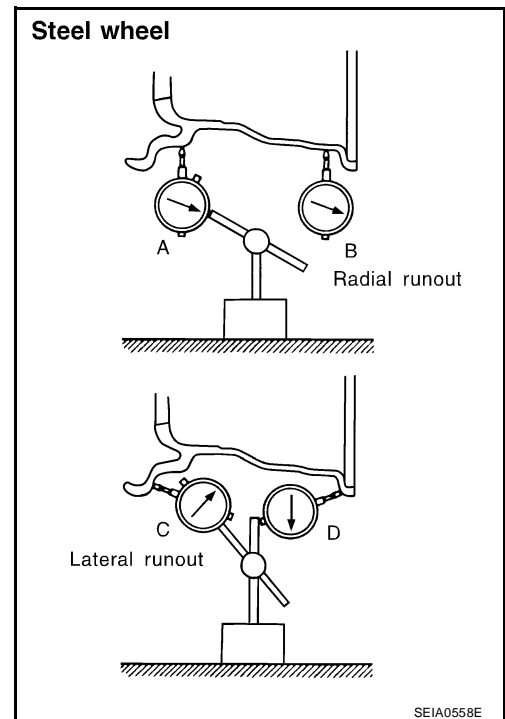

ROAD WHEEL TIRE ASSEMBLY

ROAD WHEEL TIRE ASSEMBLY

PFP:40300

Balancing Wheels

EES002D8

Adjust wheel balance using road wheel center.

CAUTION:

- Be careful not to scratch the road wheel during removal.
- Use clip-on type wheel balance weights only.

Wheel balance (Maximum allowable unbalance):

Maximum allowable unbalance	Dynamic (At rim flange)	Less than 5 g (0.18 oz) (one side)
	Static (At rim flange)	Less than 10 g (0.35 oz)

Rotation

EES002D9

- Follow the maintenance schedule for tire rotation service intervals. Refer to [MA-7, "PERIODIC MAINTENANCE"](#).
- Do not include the T-type spare tire when rotating tires.

CAUTION:

- When installing wheels, tighten them diagonally by dividing the work two to three times in order to prevent the wheels from developing any distortion.
- Be careful not to tighten wheel nut at torque exceeding the specification to prevent damage of disc rotor.

Wheel nut : 113 N·m (12 kg·m, 83 ft·lb)

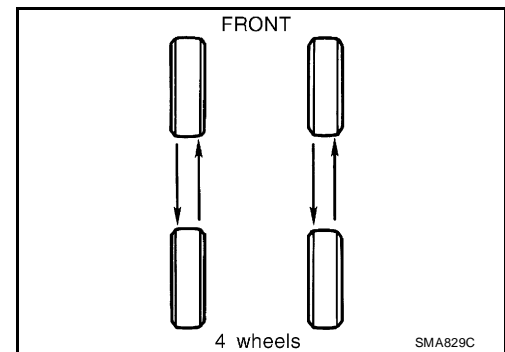

TIRE PRESSURE MONITORING SYSTEM

TIRE PRESSURE MONITORING SYSTEM

PF:40300

System Components

EES002FF

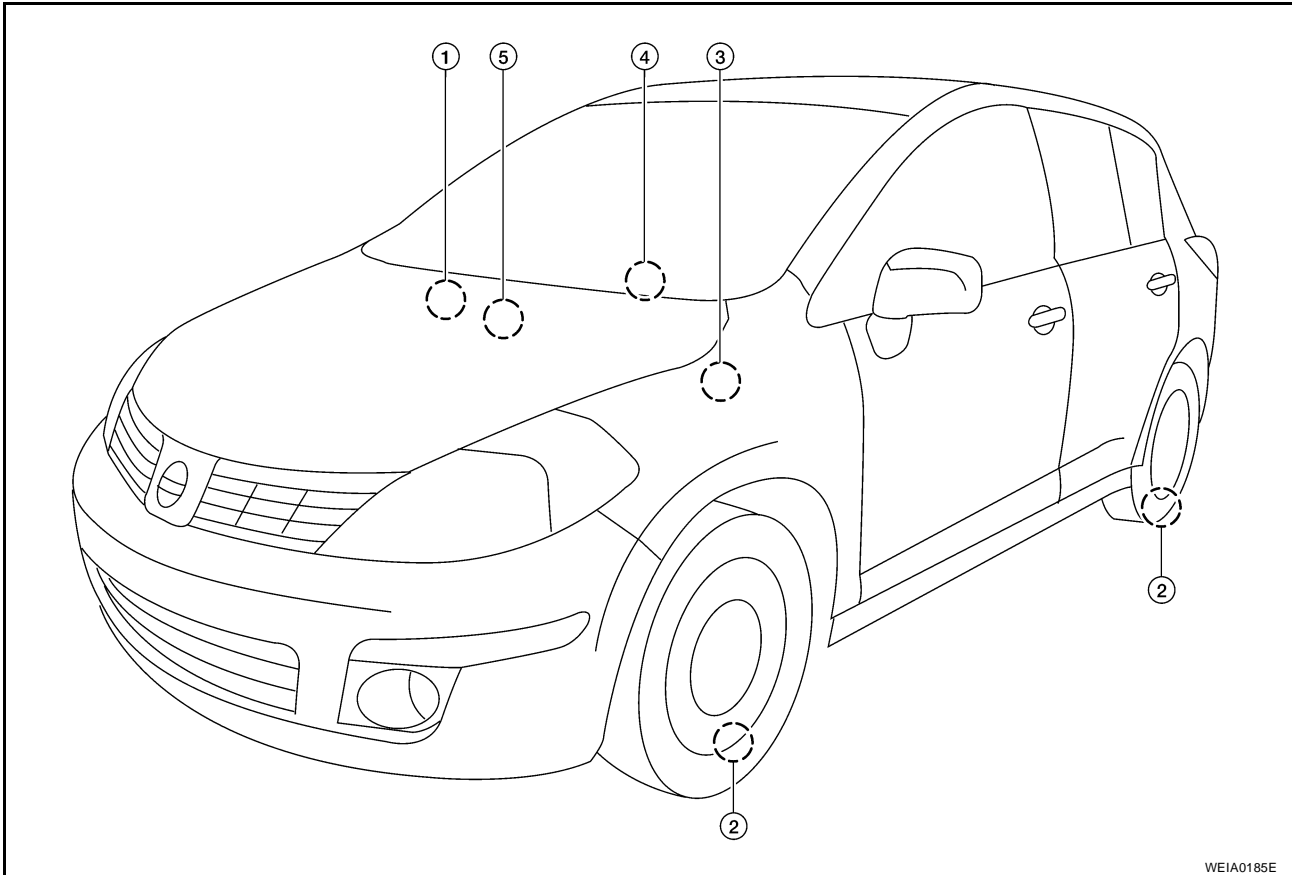

WEIA0185E

- | | | |
|-----------------------------|---|---|
| 1. BCM
M18, M20 | 2. Transmitters | 3. Tire pressure warning check connector
M39 |
| 4. Combination meter
M24 | 5. Remote keyless entry receiver
M23 | |

System Description BODY CONTROL MODULE (BCM)

EES002FG

The BCM is shown with the glove box removed. The BCM reads the air pressure signal received by the remote keyless entry receiver, and controls the low tire pressure warning lamp as shown below. It also has a self-diagnosis function to detect a system malfunction.

Condition	Low tire pressure warning lamp
System normal	On for 1 second after ignition ON
Tire less than 193 kPa (2.0 kg/cm ² , 28 psi) [Flat tire]	ON
Tire pressure monitoring system malfunction	After key ON, flashes once per second for 1 minute, then stays ON

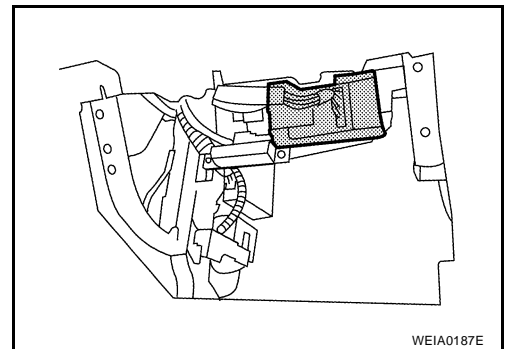

WEIA0187E

TIRE PRESSURE MONITORING SYSTEM

TRANSMITTER

A sensor-transmitter integrated with a valve is installed in each wheel, and transmits a detected air pressure signal in the form of a radio wave. The radio signal is received by the remote keyless entry receiver.

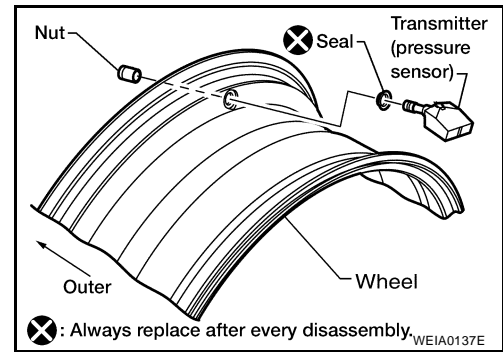

REMOTE KEYLESS ENTRY RECEIVER

The remote keyless entry receiver is shown with the glove box removed. The remote keyless entry receiver receives the air pressure signal transmitted by the transmitter in each wheel.

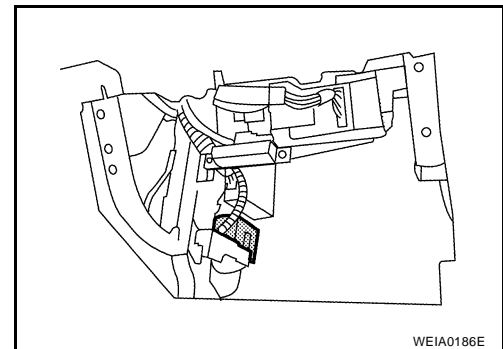

COMBINATION METER

The combination meter receives tire pressure status from the BCM using CAN communication. When a low tire pressure condition is sensed by the BCM, the combination meter low tire pressure warning lamp is activated.

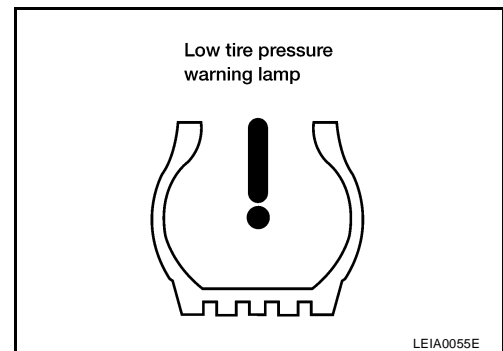

CAN COMMUNICATION

CAN COMMUNICATION

PFP:23710

System Description

EES002EU

Refer to [LAN-4, "SYSTEM DESCRIPTION"](#) .

A

B

C

D

WT

F

G

H

I

J

K

L

M

TROUBLE DIAGNOSES

PFP:00004

TROUBLE DIAGNOSES

Wiring Diagram — T/WARN —

EES002EW

WT-T/WARN-01

— — — : DATA LINE

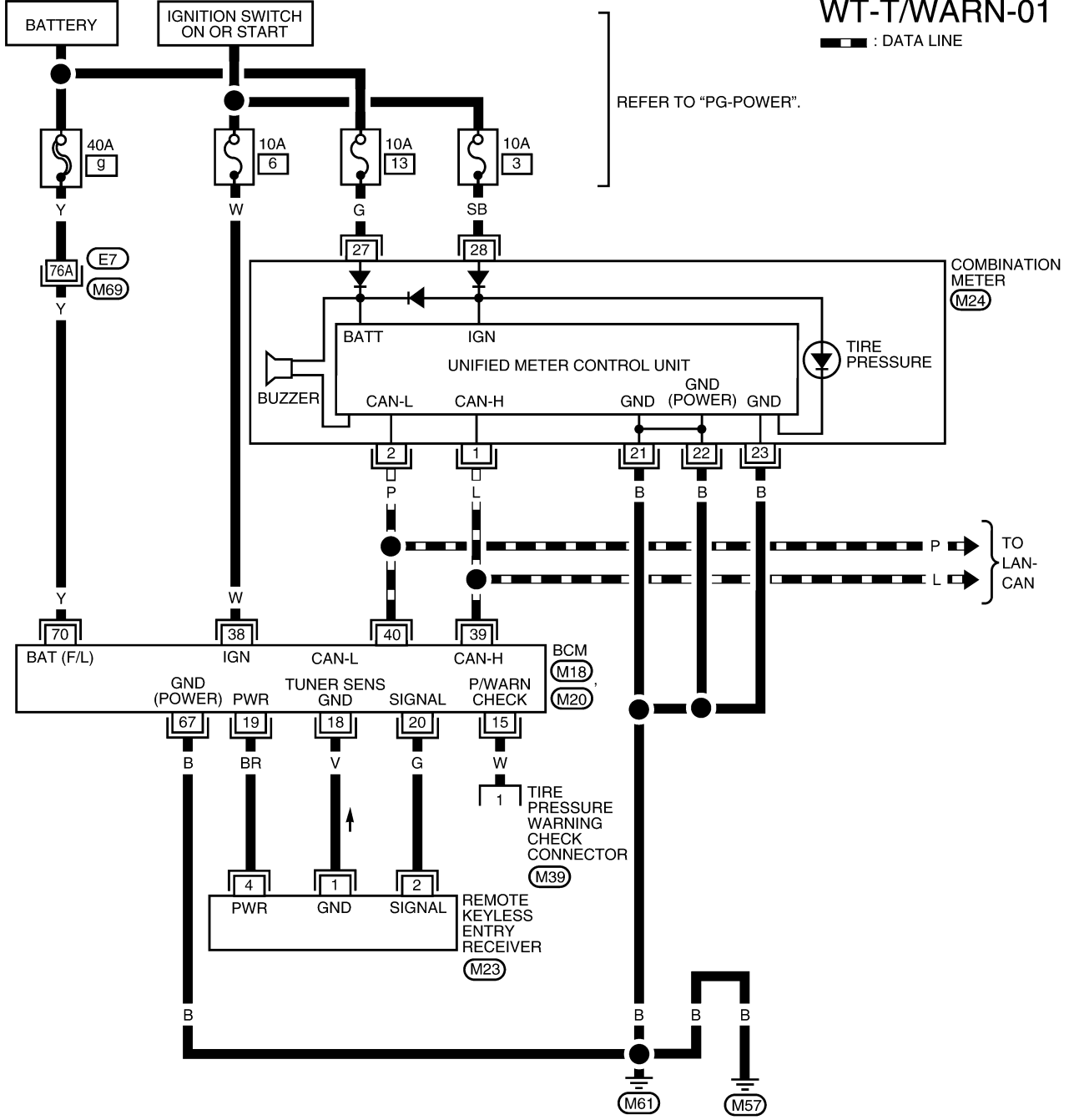

REFER TO "PG-POWER".

COMBINATION METER (M24)

TO LAN-CAN

TIRE PRESSURE WARNING CHECK CONNECTOR (M39)

BCM (M18), (M20)

REMOTE KEYLESS ENTRY RECEIVER (M23)

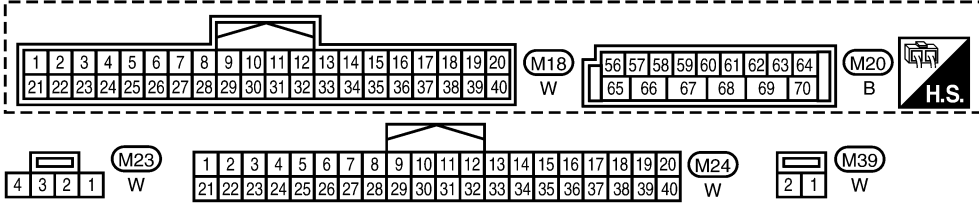

REFER TO THE FOLLOWING.
 (M69) - SUPER MULTIPLE JUNCTION (SMJ)



WEWA0068E

TROUBLE DIAGNOSES

Terminals and Reference Values for BCM

EES002EX

Refer to [BCS-13, "Terminals and Reference Values for BCM"](#) .

ID Registration Procedure

EES002EY

ID REGISTRATION WITH TRANSMITTER ACTIVATION TOOL

NOTE:

This procedure must be done after replacement of a low tire pressure warning transmitter or BCM. New replacement transmitters are provided "asleep" and must first be "woken up" using Transmitter Activation Tool J-45295 before ID registration can be performed.

1. Connect CONSULT-II. Refer to [GI-38, "CONSULT-II Start Procedure"](#) .
2. Select "AIR PRESSURE MONITOR" on "SELECT TEST ITEM" screen.
3. Select "WORK SUPPORT" on "SELECT DIAG MODE" screen, and select "ID REGIST".

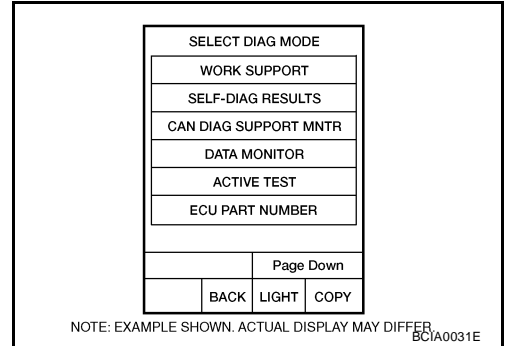

4. Push the transmitter activation tool against the tire near the front left transmitter. Press the button for 5 seconds.

Tool number : (J-45295)

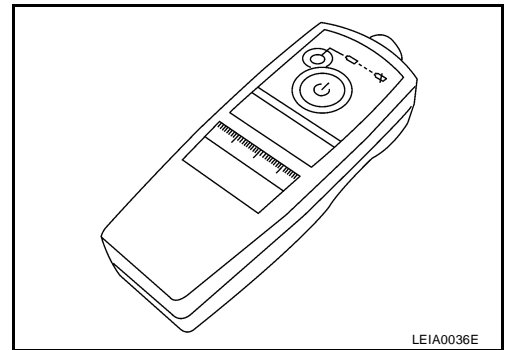

5. Register the IDs in order from FR LH, FR RH, RR RH and RR LH. When ID registration of each wheel has been completed, a buzzer sounds and the hazard warning lamps flash.

Activation tire position	Buzzer	Hazard warning lamp	CONSULT-II
1 Front LH	Once	2 times flashing	"YET" ↓ "DONE"
2 Front RH	2 times		
3 Rear RH	3 times		
4 Rear LH	4 times		

6. After completing all ID registrations, press "END" to complete the procedure.

NOTE:

Be sure to register the IDs in order from FR LH, FR RH, RR RH, to RR LH, or the self-diagnostic results display will not function properly.

TROUBLE DIAGNOSES

ID REGISTRATION WITHOUT TRANSMITTER ACTIVATION TOOL

NOTE:

This procedure must be done after replacement of a low tire pressure warning transmitter or BCM. New replacement transmitters are provided "asleep" and must first be "woken up" using Transmitter Activation Tool J-45295 before ID registration can be performed.

1. Connect CONSULT-II. Refer to [GI-38, "CONSULT-II Start Procedure"](#) .
2. Select "AIR PRESSURE MONITOR" on "SELECT TEST ITEM" screen.
3. Select "WORK SUPPORT" on "SELECT DIAG MODE" screen, and select "ID REGIST".
4. Adjust the tire pressure to the values shown in the table below and drive the vehicle at 15 km/h (9.4 MPH) or more for a few minutes.

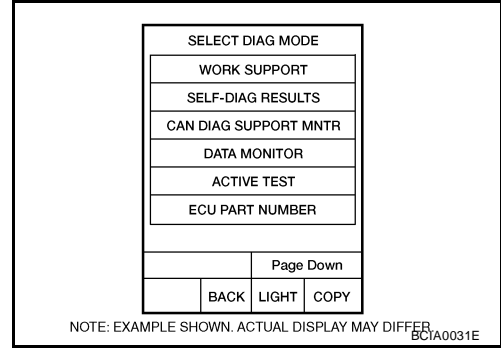

Tire position	Tire pressure kPa (kg/cm ² , psi)
Front – Left	250 (2.5, 36)
Front – Right	230 (2.3, 33)
Rear – Right	210 (2.1, 30)
Rear – Left	190 (1.9, 27)

5. After completing all ID registrations, press "END" to complete the procedure.

Activation tire position	CONSULT-II
Front LH	"YET" ↓ "DONE"
Front RH	
Rear RH	
Rear LH	

6. Inflate all tires to proper pressure. Refer to [WT-29, "Tire"](#) .

TROUBLE DIAGNOSES

EES002EZ

Transmitter Wake Up Operation

NOTE:

This procedure must be done after replacement of a low tire pressure warning transmitter or BCM. New replacement transmitters are provided "asleep" and must first be "woken up" using Transmitter Activation Tool J-45295 before ID registration can be performed.

1. Turn ignition switch ON. Push the transmitter activation tool against the tire near the front left transmitter. Press the button for 5 seconds. The hazard warning lamps flash per the diagram below.

Tool number : (J-45295)

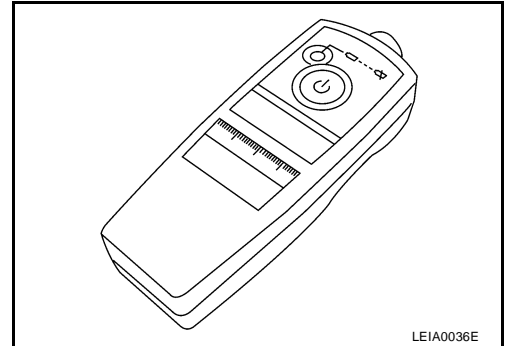

2. Repeat this procedure for each tire in the following order: FL, FR, RR, RL.
3. When the BCM finishes assigning each tire ID, the BCM flashes the hazard warning lamps and sends flashing indicator status by CAN according to the following time chart.

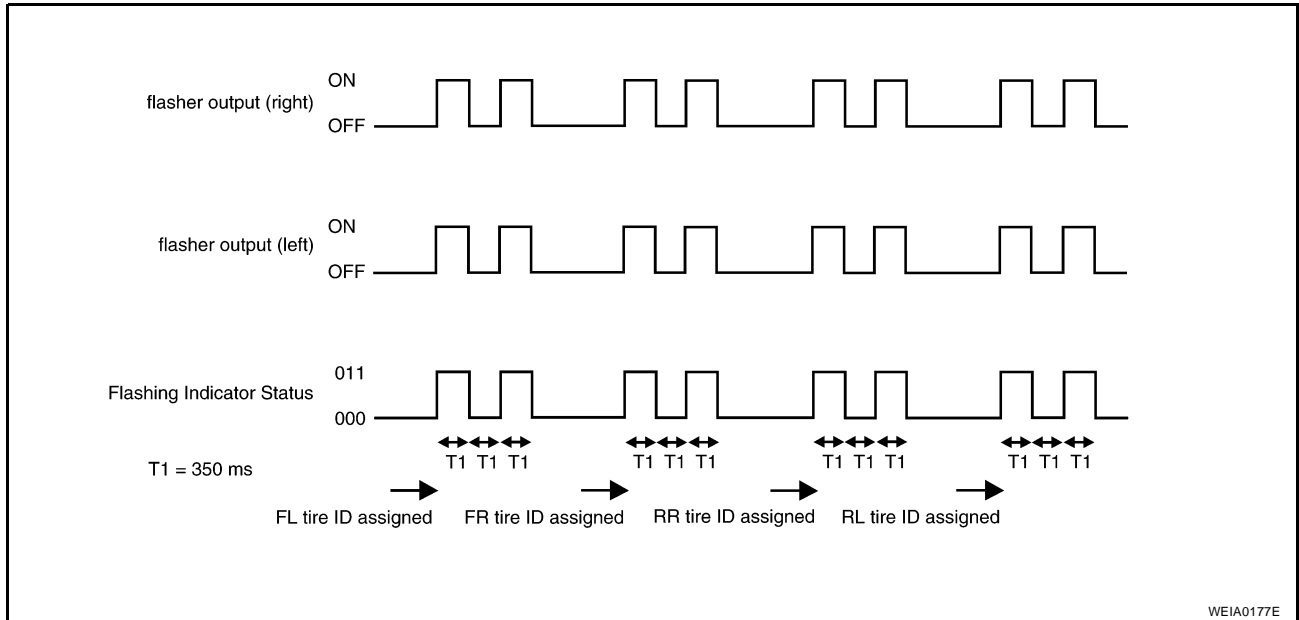

4. After completing wake up of all transmitters, make sure low tire pressure warning lamp goes out.

TROUBLE DIAGNOSES

CONSULT-II Function (BCM)

EES002F0

CONSULT-II can display each diagnostic item using the diagnostic test modes shown following.

BCM diagnostic test item	Diagnostic mode	Description
Inspection by part	WORK SUPPORT	Supports inspections and adjustments. Commands are transmitted to the BCM for setting the status suitable for required operation, input/output signals are received from the BCM and received data is displayed.
	DATA MONITOR	Displays BCM input/output data in real time.
	ACTIVE TEST	Operation of electrical loads can be checked by sending drive signal to them.
	SELF-DIAG RESULTS	Displays BCM self-diagnosis results.
	CAN DIAG SUPPORT MNTR	The result of transmit/receive diagnosis of CAN communication can be read.
	ECU PART NUMBER	BCM part number can be read.
	CONFIGURATION	Performs BCM configuration read/write functions.

TROUBLE DIAGNOSES

How to Perform Trouble Diagnosis for Quick and Accurate Repair

EES002F3

INTRODUCTION

- Before troubleshooting, verify customer complaints.
- If a vehicle malfunction is difficult to reproduce, harnesses, harness connectors or terminals may be malfunctioning. Hold and shake these parts to make sure they are securely connected.
- When using a circuit tester to measure voltage or resistance of each circuit, be careful not to damage or deform connector terminals.

WORK FLOW

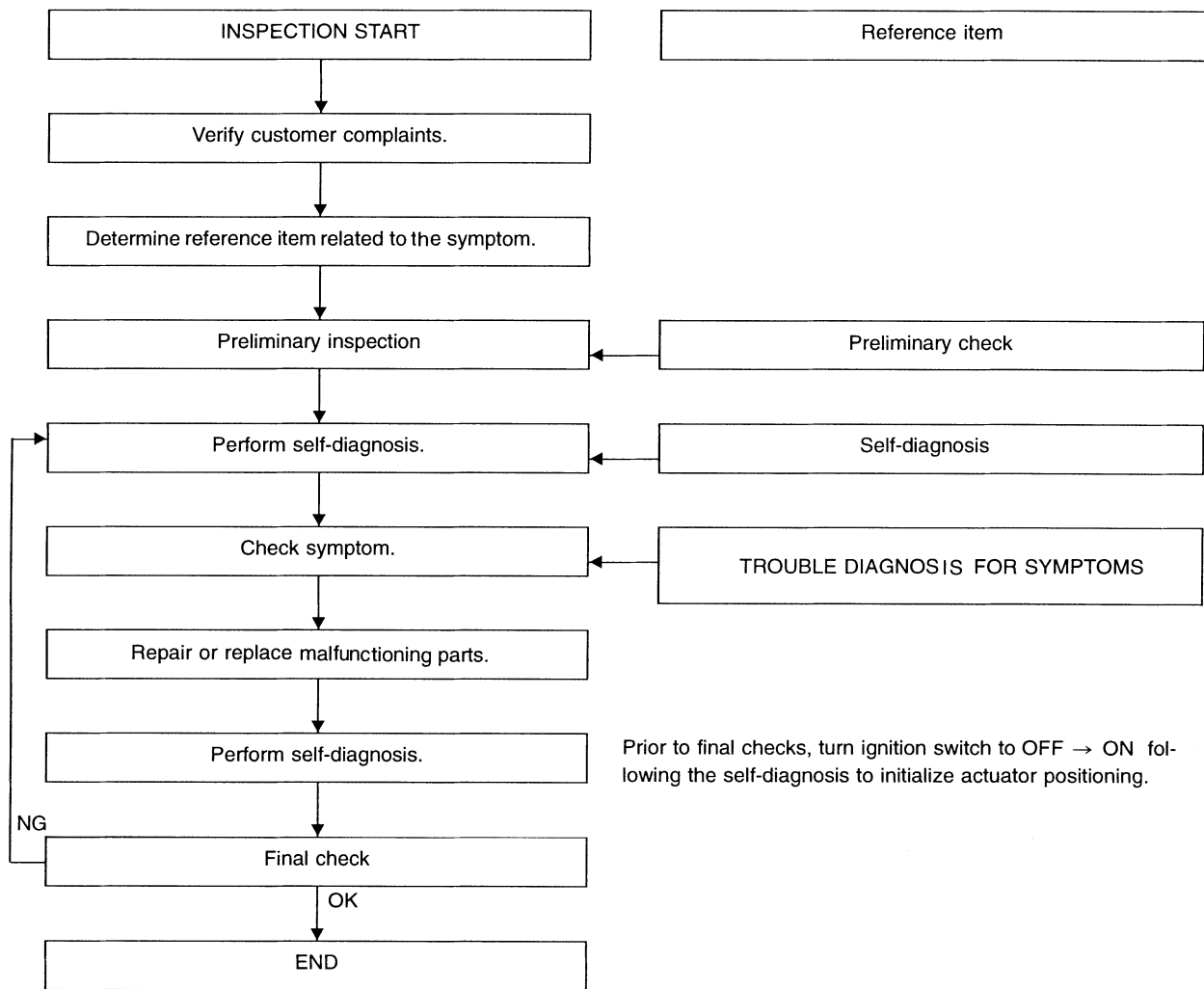

Preliminary check :

[WT-16](#)

Self-diagnosis :

[WT-16](#)

Trouble diagnosis for symptoms :

[WT-23](#)

SEIA0100E

TROUBLE DIAGNOSES

EES002F4

Preliminary Check

BASIC INSPECTION

1. CHECK ALL TIRE PRESSURES

Check all tire pressures. Refer to [WT-29, "Tire"](#) .

OK or NG

- OK >> GO TO 2.
- NG >> Adjust tire pressure to specified value.

2. CHECK LOW TIRE PRESSURE WARNING LAMP ACTIVATION

Check low tire pressure warning lamp activation.

Does warning lamp activate for 1 second when ignition switch is turned ON?

- YES >> GO TO 3.
- NO >> GO TO [WT-23, "Low Tire Pressure Warning Lamp Does Not Come On When Ignition Switch Is Turned On."](#) .

3. CHECK BCM CONNECTOR

1. Disconnect BCM harness connector.
2. Check terminals for damage or loose connection.
3. Reconnect harness connector.

OK or NG

- OK >> GO TO 4.
- NG >> Repair or replace damaged parts.

4. CHECK TRANSMITTER ACTIVATION TOOL

Check transmitter activation tool battery.

OK or NG

- OK >> Carry out self-diagnosis.
- NG >> Replace battery in transmitter activation tool.

Self-Diagnosis

EES002F1

DESCRIPTION

During driving, the tire pressure monitoring system receives the signal transmitted from the transmitter installed in each wheel, and turns on the low tire pressure warning lamp when the tire pressure becomes low. The control unit (BCM) for this system has pressure judgement and self-diagnosis functions.

FUNCTION

When the tire pressure monitoring system detects low inflation pressure or an internal malfunction, the low tire pressure warning lamp in the combination meter comes on. The malfunction location is indicated by the low tire pressure warning lamp flashing and the buzzer sounding.

CONSULT-II Application to Tire Pressure Monitoring System

ITEM	SELF-DIAGNOSTIC RESULTS	DATA MONITOR
Front - Left transmitter	×	×
Front - Right transmitter	×	×
Rear - Left transmitter	×	×
Rear - Right transmitter	×	×
Warning lamp	—	×
Vehicle speed	×	×
Buzzer (in combination meter)	—	×
CAN Communication	×	×

× : Applicable

TROUBLE DIAGNOSES

– : Not applicable

A

B

C

D

WT

F

G

H

I

J

K

L

M

TROUBLE DIAGNOSES

Self-Diagnostic Results Mode

Diagnostic item		Diagnostic item is detected when ...	Reference page
Program card UED06A or earlier	Program card UED06B or later		
FLAT - TIRE - FL [C1704] FLAT - TIRE - FR [C1705] FLAT - TIRE - RR [C1706] FLAT - TIRE - RL [C1707]	LOW - PRESSURE - FL [C1704] LOW - PRESSURE - FR [C1705] LOW - PRESSURE - RR [C1706] LOW - PRESSURE - RL [C1707]	FL tire pressure 193 kPa (2.0 kg/cm ² , 28 psi) or less FR tire pressure 193 kPa (2.0 kg/cm ² , 28 psi) or less RR tire pressure 193 kPa (2.0 kg/cm ² , 28 psi) or less RL tire pressure 193 kPa (2.0 kg/cm ² , 28 psi) or less	—
[NO-DATA] - FL [C1708] [NO-DATA] - FR [C1709] [NO-DATA] - RR [C1710] [NO-DATA] - RL [C1711]		Data from FL transmitter cannot be received. Data from FR transmitter cannot be received. Data from RR transmitter cannot be received. Data from RL transmitter cannot be received.	WT-20
[CHECKSUM- ERR] - FL [CHECKSUM- ERR] - FR [CHECKSUM- ERR] - RR [CHECKSUM- ERR] - RL		Checksum data from FL transmitter is malfunctioning. Checksum data from FR transmitter is malfunctioning. Checksum data from RR transmitter is malfunctioning. Checksum data from RL transmitter is malfunctioning.	WT-20
[PRESSDATA- ERR] - FL [PRESSDATA- ERR] - FR [PRESSDATA- ERR] - RR [PRESSDATA- ERR] - RL		Air pressure data from FL transmitter is malfunctioning. Air pressure data from FR transmitter is malfunctioning. Air pressure data from RR transmitter is malfunctioning. Air pressure data from RL transmitter is malfunctioning.	WT-21
[CODE- ERR] - FL [CODE- ERR] - FR [CODE- ERR] - RR [CODE- ERR] - RL		Function code data from FL transmitter is malfunctioning. Function code data from FR transmitter is malfunctioning. Function code data from RR transmitter is malfunctioning. Function code data from RL transmitter is malfunctioning.	WT-20
[BATT - VOLT - LOW] - FL [BATT - VOLT - LOW] - FR [BATT - VOLT - LOW] - RR [BATT - VOLT - LOW] - RL		Battery voltage of FL transmitter drops. Battery voltage of FR transmitter drops. Battery voltage of RR transmitter drops. Battery voltage of RL transmitter drops.	WT-20
VHCL_SPEED_SIG_ERR [C1729]		Vehicle speed signal is in error.	WT-22

NOTE:

Before performing the self-diagnosis, be sure to register the ID or else the actual malfunction location may be different from that displayed on CONSULT-II.

Data Monitor Mode

MONITOR	CONDITION	SPECIFICATION
VHCL SPEED	Drive vehicle.	Vehicle speed (km/h or MPH)
AIR PRESS FL AIR PRESS FR AIR PRESS RR AIR PRESS RL	<ul style="list-style-type: none"> ● Drive vehicle for a few minutes. <li style="text-align: center;">or ● Ignition switch ON and activation tool is transmitting activation signals. 	Tire pressure (kPa or psi)
ID REGST FL1 ID REGST FR1 ID REGST RR1 ID REGST RL1	Ignition switch ON	Registration ID: DONE No registration ID: YET
WARNING LAMP		Low tire pressure warning lamp on: ON Low tire pressure warning lamp off: OFF
BUZZER		Buzzer in combination meter on: ON Buzzer in combination meter off: OFF

NOTE:

Before performing the self-diagnosis, be sure to register the ID, or the actual malfunction location may be different from that displayed on CONSULT-II.

TROUBLE DIAGNOSES

Flash Code/Symptom Chart

EES002F2

A
B
C
D
WT
F
G
H
I
J
K
L
M

Flash Code or Symptom	Malfunction part	Reference page
15 16 17 18	FL tire pressure drops to 193 kPa (2.0 kg/cm ² , 28 psi) or less FR tire pressure drops to 193 kPa (2.0 kg/cm ² , 28 psi) or less RR tire pressure drops to 193 kPa (2.0 kg/cm ² , 28 psi) or less RL tire pressure drops to 193 kPa (2.0 kg/cm ² , 28 psi) or less	—
21 22 23 24	Transmitter no data (FL) Transmitter no data (FR) Transmitter no data (RR) Transmitter no data (RL)	WT-20
31 32 33 34	Transmitter checksum error (FL) Transmitter checksum error (FR) Transmitter checksum error (RR) Transmitter checksum error (RL)	WT-20
35 36 37 38	Transmitter pressure data error (FL) Transmitter pressure data error (FR) Transmitter pressure data error (RR) Transmitter pressure data error (RL)	WT-21
41 42 43 44	Transmitter function code error (FL) Transmitter function code error (FR) Transmitter function code error (RR) Transmitter function code error (RL)	WT-20
45 46 47 48	Transmitter battery voltage low (FL) Transmitter battery voltage low (FR) Transmitter battery voltage low (RR) Transmitter battery voltage low (RL)	WT-20
52	Vehicle speed signal	WT-22
Low tire pressure warning lamp does not come on when ignition switch is turned on.	<ul style="list-style-type: none"> ● Fuse or combination meter ● BCM connector or circuit ● BCM 	WT-23
Low tire pressure warning lamp stays on when ignition switch is turned on.	<ul style="list-style-type: none"> ● Combination meter ● BCM connector or circuit ● BCM 	WT-23
Low tire pressure warning lamp flashes when ignition switch is turned on.	<ul style="list-style-type: none"> ● BCM harness connector or circuit ● BCM ● Transmitter's mode off ● ID registration not completed yet 	WT-25
Hazard warning lamps flash when ignition switch is turned on.	<ul style="list-style-type: none"> ● BCM harness connector or circuit ● BCM 	WT-26
ID registration cannot be completed.	<ul style="list-style-type: none"> ● Transmitter ● Remote keyless entry receiver harness connector or circuit ● Remote keyless entry receiver ● BCM harness connector or circuit ● BCM 	WT-26

TROUBLE DIAGNOSIS FOR SELF-DIAGNOSTIC ITEMS

TROUBLE DIAGNOSIS FOR SELF-DIAGNOSTIC ITEMS

PF0:0000

Data From Transmitter Not Being Received MALFUNCTION CODE NO. 21, 22, 23 OR 24 (DTC C1708, C1709, C1710 OR C1711)

EES002F5

1. CHECK BCM

Drive for several minutes. Check all tire pressures with CONSULT-II.

Are all tire pressures displayed as 0 kPa?

- YES >> GO TO 2.
- NO >> GO TO 3.

2. CHECK REMOTE KEYLESS ENTRY RECEIVER CONNECTOR

Check remote keyless entry receiver connector for damage or loose connections.

OK or NG

- OK >> Replace BCM, then GO TO 3. Refer to [BCS-27, "Removal and Installation of BCM"](#) .
- NG >> Repair or replace remote keyless entry receiver connector.

3. PERFORM ID REGISTRATION

Carry out ID registration of all transmitters. Refer to [WT-11, "ID Registration Procedure"](#) .

Is there a tire that cannot register ID?

- YES >> Replace transmitter of the tire, then GO TO 5. Refer to [WT-27, "Transmitter \(Pressure Sensor\)"](#) .
- NO >> GO TO 4.

4. DRIVE VEHICLE

1. Drive at a speed of 40 km/h (25 MPH) or more for several minutes without stopping.
2. Check all tire pressures with CONSULT-II within 15 minutes after vehicle speed becomes 17 km/h (11 MPH).

Does "DATA MONITOR ITEM" display tire pressure as normal without any warning lamp?

- YES >> Inspection End.
- NO >> GO TO 5.

5. ID REGISTRATION AND VEHICLE DRIVING

1. Carry out ID registration of all transmitters. Refer to [WT-11, "ID Registration Procedure"](#) .
2. Drive at a speed of 40 km/h (25 MPH) or more for 3 minutes, and then drive the vehicle at any speed for 10 minutes.
3. Check all tire pressures with CONSULT-II within 5 minutes.

Does "DATA MONITOR ITEM" display tire pressure as normal without any warning lamp?

- YES >> Inspection End.
- NO >> GO TO the inspection applicable to DTC.

Transmitter Malfunction MALFUNCTION CODE NO. 31, 32, 33, 34, 41, 42, 43, 44, 45, 46, 47 OR 48

EES002F6

1. PERFORM ID REGISTRATION

1. Carry out ID registration of all transmitters. Refer to [WT-11, "ID Registration Procedure"](#) .
2. Drive at a speed of 40 km/h (25 MPH) or more for 3 minutes, and then drive the vehicle at any speed for 10 minutes.

>> GO TO 2.

TROUBLE DIAGNOSIS FOR SELF-DIAGNOSTIC ITEMS

2. REPLACE TRANSMITTER

1. Check low tire pressure warning lamp again for flashing, replace malfunctioning transmitter. Refer to [WT-27, "Transmitter \(Pressure Sensor\)"](#) .
 2. Carry out ID registration of all transmitters. Refer to [WT-11, "ID Registration Procedure"](#) .
- Can ID registration of all transmitters be completed?

YES >> GO TO 3.

NO >> GO TO [WT-20, "Data From Transmitter Not Being Received"](#) .

3. DRIVE VEHICLE

1. Drive at a speed of 40 km/h (25 MPH) or more for 3 minutes, and then drive the vehicle at any speed for 10 minutes.
2. Check all tire pressures with CONSULT-II within 5 minutes.

Does "DATA MONITOR ITEM" display tire pressure as normal without any warning lamp?

YES >> Inspection End.

NO >> Replace malfunctioning transmitter, and perform Step 3 again. Refer to [WT-27, "Transmitter \(Pressure Sensor\)"](#) .

Transmitter Pressure Malfunction MALFUNCTION CODE NO. 35, 36, 37 OR 38

EES002F7

1. CHECK ALL TIRE PRESSURES

Check all tire pressures. Refer to [WT-29, "Tire"](#) .

Are there any tires with pressure of 64 psi or more?

YES >> Adjust tire pressure to specified value.

NO >> GO TO 2.

2. ID REGISTRATION AND VEHICLE DRIVING

1. Carry out ID registration of all transmitters. Refer to [WT-11, "ID Registration Procedure"](#) .
2. Drive at a speed of 40 km/h (25 MPH) or more for several minutes without stopping.
3. Check all tire pressures with CONSULT-II within 15 minutes after vehicle speed becomes 17 km/h (11 MPH).

Does "DATA MONITOR ITEM" display 64 psi or more?

YES >> Replace transmitter. Refer to [WT-27, "Transmitter \(Pressure Sensor\)"](#) . GO TO 3.

NO >> GO TO 3.

3. ID REGISTRATION AND VEHICLE DRIVING

1. Carry out ID registration of all transmitters. Refer to [WT-11, "ID Registration Procedure"](#) .
2. Drive at a speed of 40 km/h (25 MPH) or more for 3 minutes, and then drive the vehicle at any speed for 10 minutes.
3. Check all tire pressures with CONSULT-II within 5 minutes.

Does "DATA MONITOR ITEM" display tire pressure as normal without any warning lamp?

YES >> Inspection End.

NO >> GO TO the inspection applicable to DTC.

TROUBLE DIAGNOSIS FOR SELF-DIAGNOSTIC ITEMS

Vehicle Speed Signal MALFUNCTION CODE NO. 52 (DTC C1729)

EES002F8

1. SELF-DIAGNOSTIC RESULT CHECK

Using CONSULT-II, check display contents in self-diagnostic results.

Is "CAN COMM CIRCUIT" displayed in the self-diagnosis display items?

- YES >> Malfunction in CAN communication system. GO TO [LAN-44, "TROUBLE DIAGNOSIS"](#) .
- NO >> GO TO 2.

2. CHECK BCM

Perform BCM diagnosis. Refer to [BCS-19, "CONSULT-II Function \(BCM\)"](#) .

Inspection results OK?

- OK >> Perform Vehicle Speed Sensor Inspection. Refer to [EC-427, "Diagnostic Procedure"](#) .
- NG >> Replace BCM. Refer to [BCS-27, "Removal and Installation of BCM"](#) .

TROUBLE DIAGNOSIS FOR SYMPTOMS

TROUBLE DIAGNOSIS FOR SYMPTOMS

PF0:0007

Low Tire Pressure Warning Lamp Does Not Come On When Ignition Switch Is Turned On.

EES002F9

DIAGNOSTIC PROCEDURE

1. SELF-DIAGNOSTIC RESULT CHECK

Using CONSULT-II, check display contents in self-diagnostic results.

Is "CAN COMM CIRCUIT" displayed in the self-diagnosis display items?

- YES >> Malfunction in CAN communication system. GO TO [LAN-44, "TROUBLE DIAGNOSIS"](#) .
- NO >> GO TO 2.

2. CHECK COMBINATION METER

Check combination meter operation. Refer to [DI-13, "Self-Diagnosis Mode of Combination Meter"](#) .

Inspection results OK?

- OK >> GO TO 3.
- NG >> Replace combination meter. Refer to [IP-19, "COMBINATION METER"](#) .

3. CHECK LOW TIRE PRESSURE WARNING LAMP

Disconnect BCM harness connector.

Does the low tire pressure warning lamp activate?

- YES >> Replace BCM. Refer to [BCS-27, "Removal and Installation of BCM"](#) .
- NO >> Check combination meter operation. Refer to [DI-13, "Self-Diagnosis Mode of Combination Meter"](#)

Low Tire Pressure Warning Lamp Stays On When Ignition Switch Is Turned On

EES002FA

DIAGNOSTIC PROCEDURE

1. CHECK BCM CONNECTORS

1. Turn ignition switch OFF.
2. Disconnect BCM harness connectors M18 and M20.
3. Check terminals for damage or loose connections.

Inspection results OK?

- OK >> GO TO 2.
- NG >> Repair or replace damaged parts.

2. CHECK BCM POWER SUPPLY CIRCUIT (BAT)

Check voltage between BCM harness connector M20 terminal 70 and ground.

Terminals		Voltage (Approx.)
(+)	(-)	
Connector	Terminal	Ground
M20	70	Battery voltage

OK or NG

- OK >> GO TO 3.
- NG >> Check BCM power supply circuit for open or short.

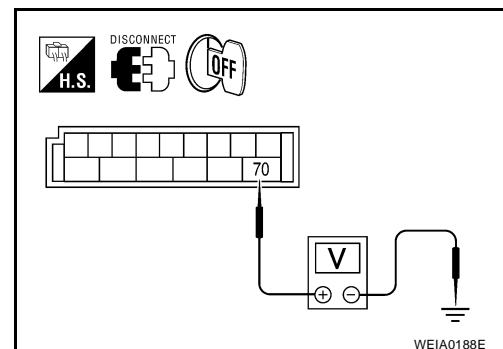

TROUBLE DIAGNOSIS FOR SYMPTOMS

3. CHECK BCM POWER SUPPLY CIRCUIT (IGN)

1. Turn ignition switch ON.
2. Check voltage between BCM harness connector M18 terminal 38 and ground.

Terminals		Voltage (Approx.)
(+)	(-)	
Connector	Terminal	Ground
M18	38	

OK or NG

- OK >> GO TO 4.
 NG >> Check BCM power supply circuit for open or short.

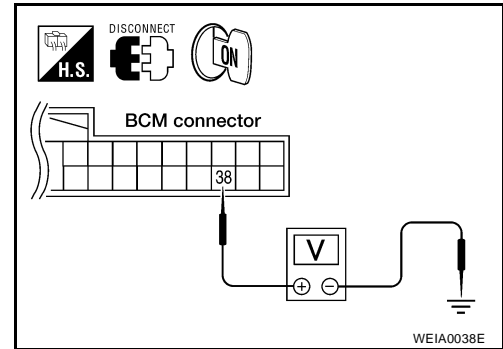

4. CHECK BCM GROUND CIRCUIT

1. Turn ignition switch OFF.
2. Check continuity between BCM harness connector M20 terminal 67 and ground.

Terminals		Continuity
(+)	(-)	
Connector	Terminal	Ground
M20	67	

OK or NG

- OK >> Replace BCM. Refer to [BCS-27, "Removal and Installation of BCM"](#) .
 NG >> Repair BCM ground circuit.

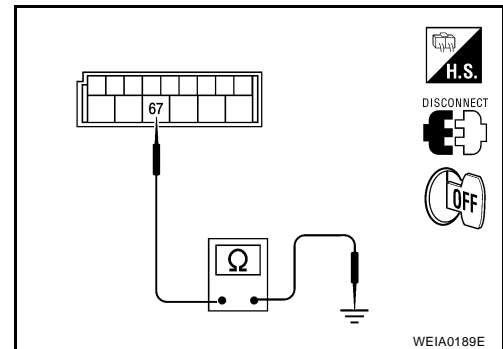

TROUBLE DIAGNOSIS FOR SYMPTOMS

Low Tire Pressure Warning Lamp Flashes When Ignition Switch Is Turned On.

EES002FB

NOTE:

If low tire pressure warning lamp flashes as shown, the system is normal.

Flash Mode A

- This mode shows transmitter status is OFF-mode. Carry out transmitter wake up operation. Refer to [WT-13, "Transmitter Wake Up Operation"](#) .

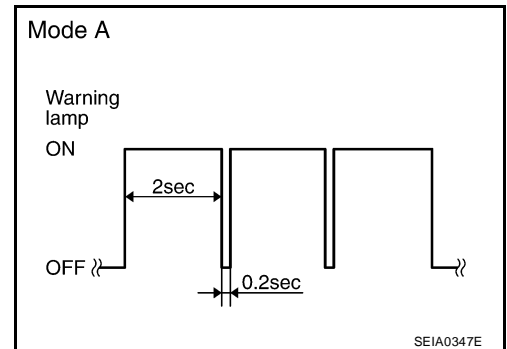

DIAGNOSTIC PROCEDURE

1. CHECK BCM CONNECTORS

1. Turn ignition switch OFF.
2. Disconnect BCM harness connectors M18 and M20.
3. Check terminals for damage or loose connections.

Inspection results OK?

- OK >> GO TO 2.
NG >> Repair or replace damaged parts.

2. CHECK TIRE PRESSURE WARNING CHECK CONNECTOR CIRCUIT

Check continuity between BCM harness connector M18 terminal 15 and check connector M39 terminal 1.

Continuity should exist.

OK or NG

- OK >> Replace BCM. Refer to [BCS-27, "Removal and Installation of BCM"](#) .
NG >> Repair or replace harness connector.

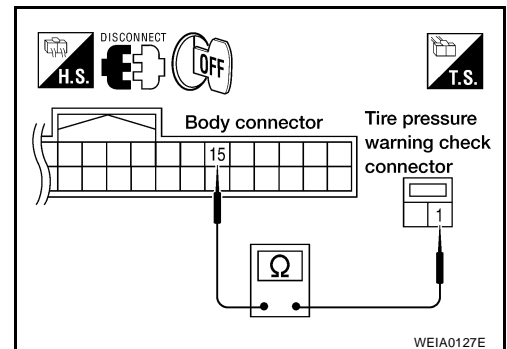

TROUBLE DIAGNOSIS FOR SYMPTOMS

Hazard Warning Lamps Flash When Ignition Switch Is Turned On

EES002FC

DIAGNOSTIC PROCEDURE

1. CHECK BCM GROUND CIRCUIT

1. Turn ignition switch OFF.
2. Disconnect BCM harness connector M20.
3. Check continuity between BCM harness connector M20 terminal 67 and ground.

Terminals		Continuity
(+)	(-)	
Connector	Terminal	Ground
M20	67	Yes

OK or NG

- OK >> Replace BCM. Refer to [BCS-27, "Removal and Installation of BCM"](#) .
- NG >> Repair BCM ground circuit.

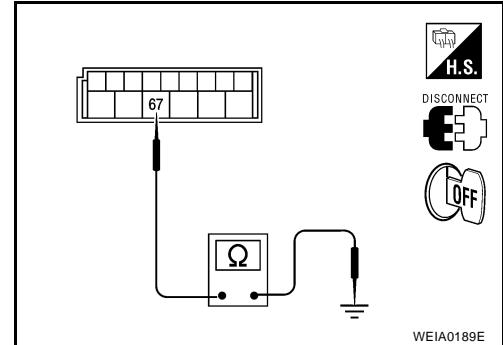

ID Registration Cannot Be Completed

EES002FE

DIAGNOSTIC PROCEDURE

1. PERFORM ID REGISTRATION OF ALL TRANSMITTERS

Carry out ID registration of all transmitters. Refer to [WT-11, "ID Registration Procedure"](#) .

Can ID registration of all transmitters be completed?

- YES >> Inspection End.
- NO >> GO TO [WT-20, "Data From Transmitter Not Being Received"](#) .

REMOVAL AND INSTALLATION

PFP:00000

EES002EG

REMOVAL AND INSTALLATION

Transmitter (Pressure Sensor) REMOVAL

1. Remove wheel and tire using power tool.
2. Deflate tire. Unscrew transmitter retaining nut and allow transmitter to fall into tire.
3. Gently bounce tire so that transmitter falls to bottom of tire. Place wheel and tire assembly on tire changing machine and break both tire beads. Ensure that the transmitter remains at the bottom of the tire while breaking the bead.

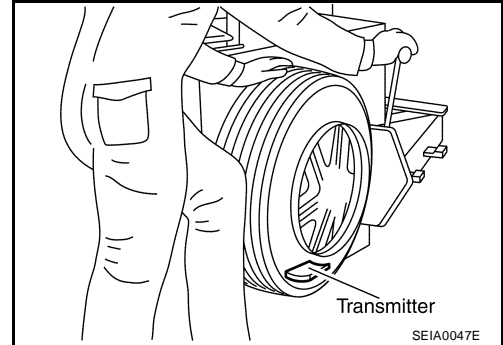

4. Turn tire so that valve hole is at bottom, and gently bounce the tire to ensure transmitter is near valve hole. Carefully lift tire onto turntable and position valve hole (and transmitter) 270 degrees from mounting/dismounting head.
5. Lubricate tire well, and remove top side of tire. Reach inside the tire and remove the transmitter.
6. Remove the second side of the tire as normal.

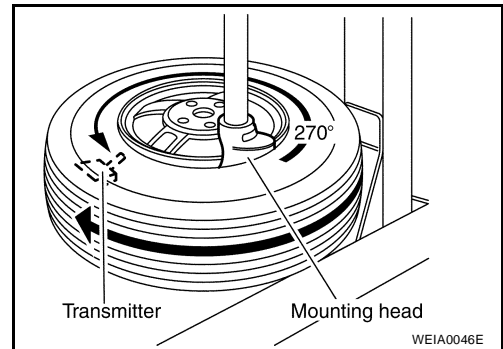

INSTALLATION

1. Place first side of tire onto rim.

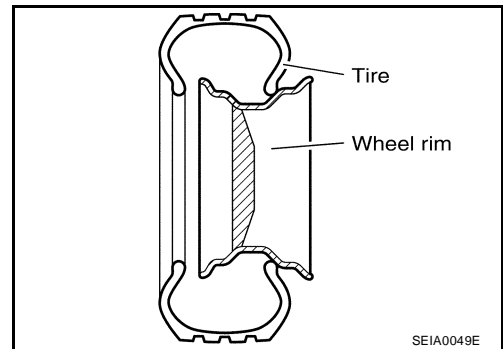

2. Apply suitable silicone lubricant to new transmitter seal then install seal on transmitter. Refer to [MA-11, "RECOMMENDED FLUIDS AND LUBRICANTS"](#).

NOTE:

Always replace the seal after every disassembly.

3. Mount transmitter on rim and tighten nut.

NOTE:

Make sure no burrs exist in the valve stem hole of the wheel.

Transmitter nut : 8.0 N·m (0.82 kg·m, 71 in·lb)

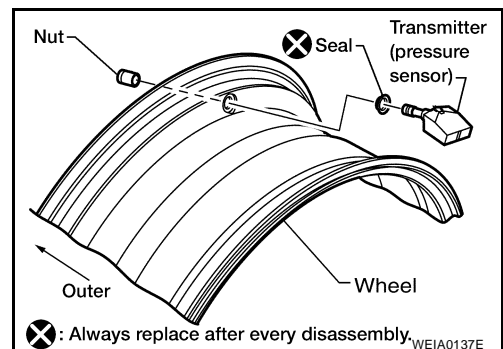

REMOVAL AND INSTALLATION

- Place wheel on turntable of tire machine. Ensure that transmitter is 270 degrees from mounting/dismounting head.

NOTE:

Do not touch transmitter with mounting head.

- Lubricate tire well, and install second side of tire as normal. Ensure that tire does not rotate relative to rim.
- Inflate tire and balance the wheel and tire assembly. Refer to [WT-6, "Balancing Wheels"](#) .
- Install wheel and tire assembly in appropriate wheel position on vehicle. Refer to [WT-6, "Rotation"](#) .

NOTE:

If replacing the transmitter, then transmitter wake up operation must be performed. Refer to [WT-13, "Transmitter Wake Up Operation"](#) .

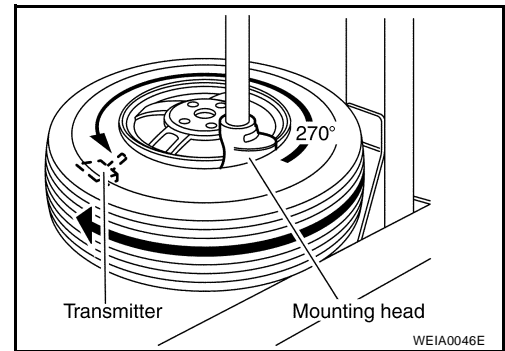

SERVICE DATA AND SPECIFICATIONS (SDS)

SERVICE DATA AND SPECIFICATIONS (SDS)

PF0:00030

Road Wheel

EES002DA

Standard item		Allowable	
		Aluminum	Steel
Maximum radial runout limit	Lateral deflection	Less than 0.3 mm (0.012 in)	Less than 0.5 mm (0.020 in)
	Radial deflection	Less than 0.3 mm (0.012 in)	Less than 0.8 mm (0.031 in)
Maximum allowable unbalance	Dynamic (At rim flange)	Less than 5 g (0.18 oz) (one side)	
	Static (At rim flange)	Less than 10 g (0.35 oz)	

Tire

EES002DB

Unit: kPa (kg/cm² , psi)

Tire size/speed rating	Air pressure		
	Conventional tire		Spare tire
	Front wheel	Rear wheel	
P185/65R15 86H	230 (2.3, 33)	230 (2.3, 33)	—
T125/70*15	—	—	420 (4.2, 60)

*: D or R depending on manufacturer.

SERVICE DATA AND SPECIFICATIONS (SDS)
