

SECTION **BCS**

BODY CONTROL SYSTEM

A
B
C
D
E
F
G
H
I
J
L
M
N
O
P

CONTENTS

SERVICE INFORMATION	2	BCM Terminal Arrangement	10
PRECAUTIONS	2	Terminal and Reference Value for BCM	11
Precaution for Supplemental Restraint System (SRS) "AIR BAG" and "SEAT BELT PRE-TEN- SIONER"	2	BCM Power Supply and Ground Circuit Inspection	15
BCM (BODY CONTROL MODULE)	3	CONSULT-III Function (BCM)	16
System Description	3	CAN Communication Inspection Using CON- SULT-III (Self-Diagnosis)	17
CAN Communication System Description	7	Configuration	17
Schematic	8	Removal and Installation of BCM	18

BCS

PRECAUTIONS

< SERVICE INFORMATION >

SERVICE INFORMATION

PRECAUTIONS

Precaution for Supplemental Restraint System (SRS) "AIR BAG" and "SEAT BELT PRE-TENSIONER"

INFOID:000000001704583

The Supplemental Restraint System such as "AIR BAG" and "SEAT BELT PRE-TENSIONER", used along with a front seat belt, helps to reduce the risk or severity of injury to the driver and front passenger for certain types of collision. This system includes seat belt switch inputs and dual stage front air bag modules. The SRS system uses the seat belt switches to determine the front air bag deployment, and may only deploy one front air bag, depending on the severity of a collision and whether the front occupants are belted or unbelted. Information necessary to service the system safely is included in the SR and SB section of this Service Manual.

WARNING:

- **To avoid rendering the SRS inoperative, which could increase the risk of personal injury or death in the event of a collision which would result in air bag inflation, all maintenance must be performed by an authorized NISSAN/INFINITI dealer.**
- **Improper maintenance, including incorrect removal and installation of the SRS, can lead to personal injury caused by unintentional activation of the system. For removal of Spiral Cable and Air Bag Module, see the SR section.**
- **Do not use electrical test equipment on any circuit related to the SRS unless instructed to in this Service Manual. SRS wiring harnesses can be identified by yellow and/or orange harnesses or harness connectors.**

BCM (BODY CONTROL MODULE)

< SERVICE INFORMATION >

BCM (BODY CONTROL MODULE)

System Description

INFOID:000000001704584

BCM (body control module) controls the operation of various electrical units installed on the vehicle.

BCM FUNCTION

BCM has a combination switch reading function for reading the operation of combination switches (light, wiper, washer, turn signal) in addition to the function for controlling the operation of various electrical components. Also, it functions as an interface that receives signals from the front air control, and sends signals to ECM using CAN communication.

COMBINATION SWITCH READING FUNCTION

1. Description

- BCM reads combination switch (light, wiper) status, and controls various electrical components according to the results.
- BCM reads information of a maximum of 20 switches by combining five output terminals (OUTPUT 1-5) and five input terminals (INPUT 1-5).

2. Operation description

- BCM activates transistors of output terminals (OUTPUT 1-5) periodically and allows current to flow in turn.
- If any (1 or more) of the switches are turned ON, circuit of output terminals (OUTPUT 1-5) and input terminals (INPUT 1-5) becomes active.
- At this time, transistors of output terminals (OUTPUT 1-5) are activated to allow current to flow. When voltage of input terminals (INPUT 1-5) corresponding to that switch changes, interface in BCM detects voltage change and BCM determines that switch is ON.

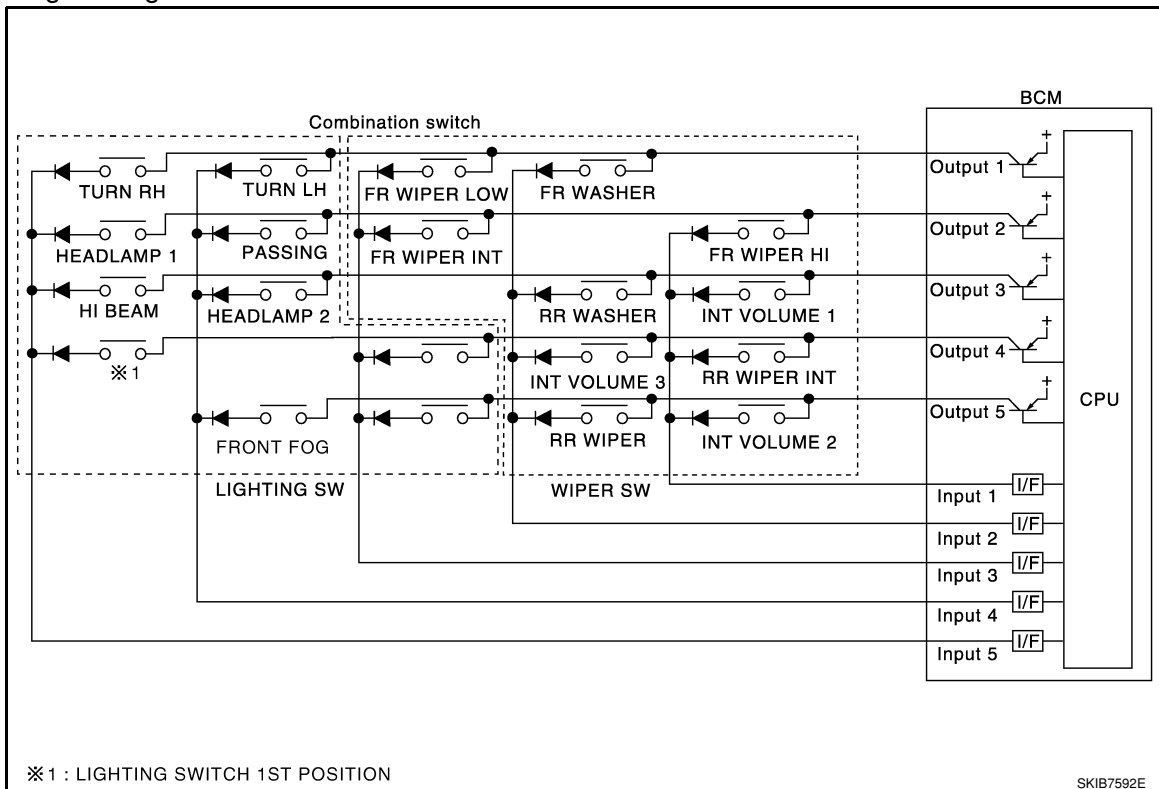

3. BCM - Operation table of combination switch

- BCM reads operation status of combination switch by the combination shown in the following table.

BCM (BODY CONTROL MODULE)

< SERVICE INFORMATION >

	COMB SW OUTPUT 1		COMB SW OUTPUT 2		COMB SW OUTPUT 3		COMB SW OUTPUT 4		COMB SW OUTPUT 5	
	ON	OFF	ON	OFF	ON	OFF	ON	OFF	ON	OFF
COMB SW INPUT 1	—	—	FRONT WIPER HI ON	FRONT WIPER HI OFF	INT VOLUME 1 ON	INT VOLUME 1 OFF	RR WIPER INT ON	RR WIPER INT OFF	INT VOLUME 2 ON	INT VOLUME 2 OFF
COMB SW INPUT 2	FRONT WASHER ON	FRONT WASHER OFF	—	—	RR WASHER ON	RR WASHER OFF	INT VOLUME 3 ON	INT VOLUME 3 OFF	RR WIPER ON	RR WIPER OFF
COMB SW INPUT 3	FRONT WIPER LO ON	FRONT WIPER LO OFF	FRONT WIPER INT ON	FRONT WIPER INT OFF	—	—	—	—	—	—
COMB SW INPUT 4	TURN LH ON	TURN LH OFF	PASSING ON	PASSING OFF	HEAD-LAMP 2 ON	HEAD-LAMP 2 OFF	—	—	FRONT FOG ON	FRONT FOG OFF
COMB SW INPUT 5	TURN RH ON	TURN RH OFF	HEAD-LAMP 1 ON	HEAD-LAMP 1 OFF	HI BEAM ON	HI BEAM OFF	LIGHTING SW (1ST) ON	LIGHTING SW (1ST) OFF	—	—

SKIB7614E

NOTE:

Headlamp has a dual system switch.

- Example operation: (When lighting switch 1st position is turned ON)
 - When lighting switch 1st position is turned ON, contact in combination switch turns ON. At this time if OUTPUT 4 transistor is activated, BCM detects that voltage changes in INPUT 5.
 - When OUTPUT 4 transistor is ON, BCM detects that voltage changes in INPUT 5, and judges lighting switch 1st position is ON. Then BCM sends tail lamp ON signal to IPDM E/R using CAN communication.
 - When OUTPUT 4 transistor is activated again, BCM detects that voltage changes in INPUT 5 and recognizes that lighting switch 1st position is continuously ON.

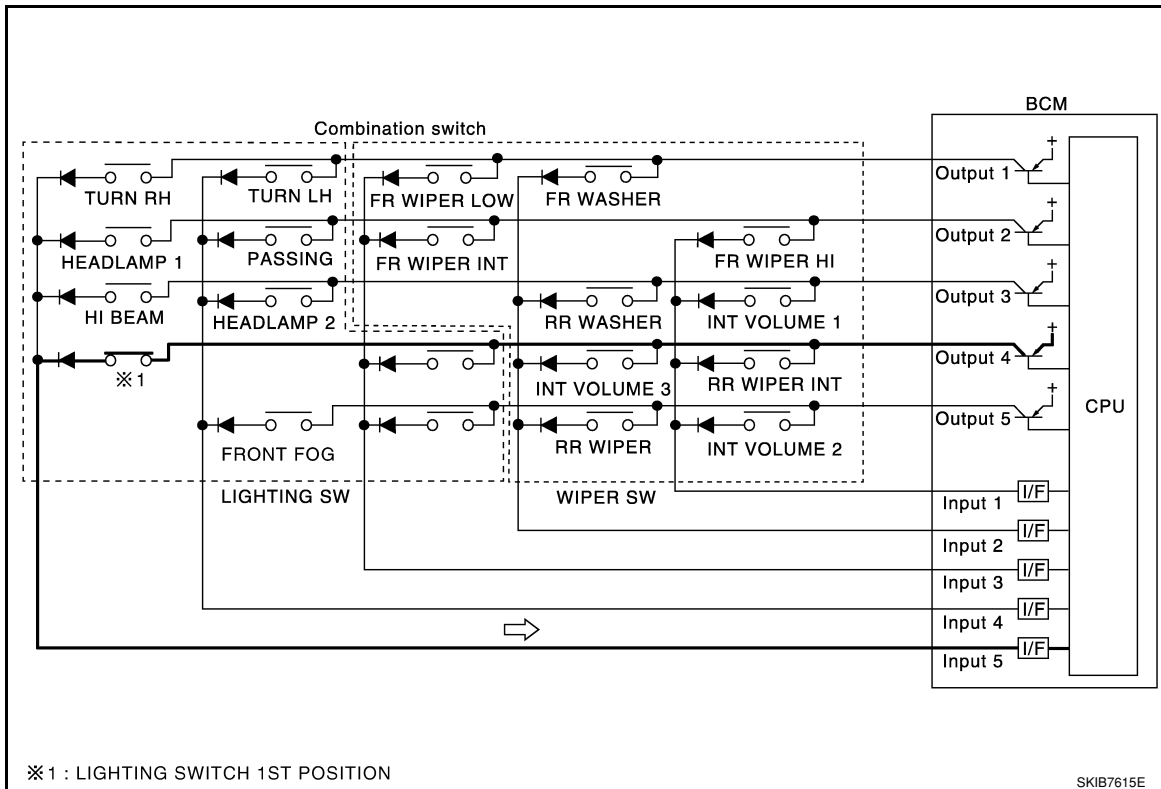

SKIB7615E

NOTE:

Each OUTPUT terminal transistor is activated at 10ms intervals. Therefore, after a switch is turned ON, electrical loads are activated with a time delay. But this time delay is so short that it cannot be noticed.

- Operation mode
 - Combination switch reading function has operation modes as follows:

BCM (BODY CONTROL MODULE)

< SERVICE INFORMATION >

Normal status

- When BCM is not in sleep status, OUTPUT terminals (1-5) each turn ON-OFF every 10ms.

Sleep status

- When BCM is in sleep mode, transistors of OUTPUT 1 and 5 stop the output, and BCM enters low-current-consumption mode. OUTPUTS (2, 3, and 4) turn ON-OFF at 60ms intervals, and receives lighting switch input only.

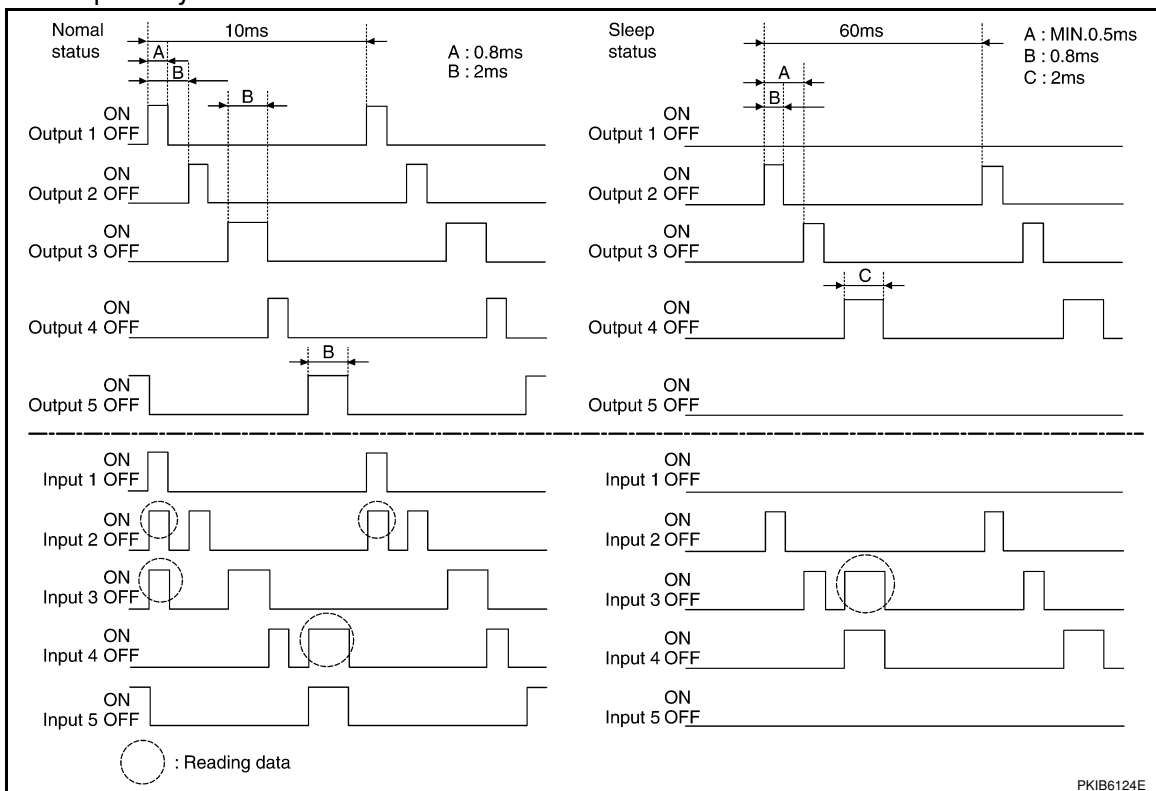

CAN COMMUNICATION CONTROL

CAN communication allows a high rate of information through the two communication lines (CAN-L, CAN-H) connecting the various control units in the system. Each control unit transmits/receives data, but selectively reads required data only.

BCM STATUS CONTROL

BCM changes its status depending on the operation status in order to save power consumption.

- CAN communication status
 - With ignition switch ON, CAN communicates with other control units normally.
 - Control by BCM is being operated properly.
 - When ignition switch is OFF, switching to sleep mode is possible.
 - Even when ignition switch is OFF, if CAN communication with IPDM E/R and combination meter is active, CAN communication status is active.
- Sleep transient status
 - This status shuts down CAN communication when ignition switch is turned OFF.
 - It transmits sleep request signal to IPDM E/R and combination meter.
 - Two seconds after CAN communication of all control units stops, CAN communication switches to inactive status.
- CAN communication inactive status
 - With ignition switch OFF, CAN communication is not active.
 - With ignition switch OFF, control performed only by BCM is active.
 - Three seconds after CAN communication of all control units stops, CAN communication switches to inactive status.
- Sleep status
 - BCM is activated with low current consumption mode.
 - CAN communication is not active.

BCM (BODY CONTROL MODULE)

< SERVICE INFORMATION >

- When CAN communication operation is detected, it switches to CAN communication status.
- When a state of the following switches changes, it switches to CAN communication state:
 - Ignition switch
 - Key switch (without Intelligent Key)
 - Key switch and ignition knob switch (with Intelligent Key)
 - Hazard switch
 - Door lock/unlock switch
 - Front door switch (LH, RH)
 - Rear door switch (LH, RH)
 - Back door lock assembly (Hatchback)
 - Trunk key cylinder switch (Sedan)
 - Trunk lamp switch and trunk release solenoid (Sedan)
 - Combination switch (passing, lighting switch 1st position, front fog lamp)
 - Keyfob (lock/unlock signal)
 - Front door key cylinder switch LH
- When control performed only by BCM is required by switch, it shifts to CAN communication inactive mode.
- Status of combination switch reading function is changed.

SYSTEMS CONTROLLED BY BCM DIRECTLY

- Power door lock system. Refer to [BL-22](#) .
- Remote keyless entry system. Refer to [BL-51](#) .
- Power window system. Refer to [GW-18](#) . ^{NOTE}
- Sunroof system. Refer to [RF-10](#) . ^{NOTE}
- Room lamp timer. Refer to [LT-89](#) .
- Rear wiper and washer system. Refer to [WW-24](#) .

NOTE:

Power supply only. No system control.

SYSTEMS CONTROLLED BY BCM AND IPDM E/R

- Panic system. Refer to [BL-51](#) .
- Vehicle security (theft warning) system. Refer to [BL-187](#) .
- NVIS(NATS) system. Refer to [BL-210](#) .
- Headlamp, tail lamp and battery saver control systems. Refer to [LT-72](#) , [LT-4](#) or [LT-25](#) .
- Front fog lamp. Refer to [LT-39](#) .
- Front wiper and washer system. Refer to [WW-3](#) .
- Rear window defogger system. Refer to [GW-49](#) .

SYSTEMS CONTROLLED BY BCM AND COMBINATION METER

- Warning chime. Refer to [DI-41](#) .
- Turn signal and hazard warning lamps. Refer to [LT-48](#) .

SYSTEMS CONTROLLED BY BCM AND INTELLIGENT KEY UNIT

- Intelligent Key system. Refer to [BL-74](#) .

MAJOR COMPONENTS AND CONTROL SYSTEM

System	Input	Output
Remote keyless entry system	Remote keyless entry receiver (keyfob)	<ul style="list-style-type: none"> • All door locking actuators • Turn signal lamp (LH, RH) • Combination meter (turn signal lamp)
Intelligent Key system	Intelligent Key unit	<ul style="list-style-type: none"> • All door locking actuators • Turn signal lamp (LH, RH) • Combination meter (turn signal lamp)
Power door lock system	Front power door lock/unlock switch (LH, RH)	All door locking actuators
Power supply (IGN/RAP) to power window	Ignition retained power supply	Power supply to power window and sunroof system
Power supply (BAT) to power window	Battery power supply	Power supply to power window and sunroof system

BCM (BODY CONTROL MODULE)

< SERVICE INFORMATION >

System	Input	Output	
Panic alarm	<ul style="list-style-type: none"> • Key switch • Keyfob 	IPDM E/R	A
Vehicle security system	<ul style="list-style-type: none"> • All door switches • Keyfob • Door lock/unlock switch • Trunk key cylinder switch (Sedan) • Front door key cylinder switch LH 	<ul style="list-style-type: none"> • IPDM/ER • Security indicator lamp 	B C
Battery saver control	<ul style="list-style-type: none"> • Ignition switch • Combination switch 	IPDM E/R	D
Headlamp	Combination switch	IPDM E/R	
Tail lamp	Combination switch	IPDM E/R	E
Front fog lamp	Combination switch	IPDM E/R	
Turn signal lamp	Combination switch	<ul style="list-style-type: none"> • Turn signal lamp • Combination meter 	F
Hazard lamp	Hazard switch	<ul style="list-style-type: none"> • Turn signal lamp • Combination meter 	
Room lamp timer	<ul style="list-style-type: none"> • Key switch • Keyfob • Main power window and door lock/unlock switch • Front door switch LH • All door switch 	Interior room lamp	G H
Back door switch signal (Hatchback)	Back door lock assembly	Luggage room lamp	
Back door lock signal (Hatchback)	Back door lock assembly	Back door opener	I
Trunk lamp switch signal	Trunk lamp switch and trunk release solenoid	Luggage room lamp	
Trunk lid opener signal	Trunk lamp switch and trunk release solenoid	Trunk lid opener	J
Key warning chime	<ul style="list-style-type: none"> • Key switch • Front door switch LH 	Combination meter (warning buzzer)	K
Light warning chime	<ul style="list-style-type: none"> • Combination switch • Key switch • Front door switch LH 	Combination meter (warning buzzer)	L
Seat belt warning chime	<ul style="list-style-type: none"> • Seat belt buckle switch LH • Ignition switch 	Combination meter (warning buzzer)	
Front wiper and washer system	<ul style="list-style-type: none"> • Combination switch • Ignition switch 	IPDM E/R	M
Rear window defogger	Rear window defogger switch	IPDM E/R	
Rear wiper and washer system	<ul style="list-style-type: none"> • Combination switch • Ignition switch 	Rear wiper motor	N
A/C switch signal	Front air control	ECM	
Blower fan switch signal	Front air control	ECM	O
A/C indicator signal	Front air control	A/C indicator	
Low tire pressure warning system	Remote keyless entry receiver	Combination meter	P

CAN Communication System Description

INFOID:000000001704585

Refer to [LAN-6. "System Description"](#).

BCM (BODY CONTROL MODULE)

< SERVICE INFORMATION >

Schematic

INFOID:000000001704586

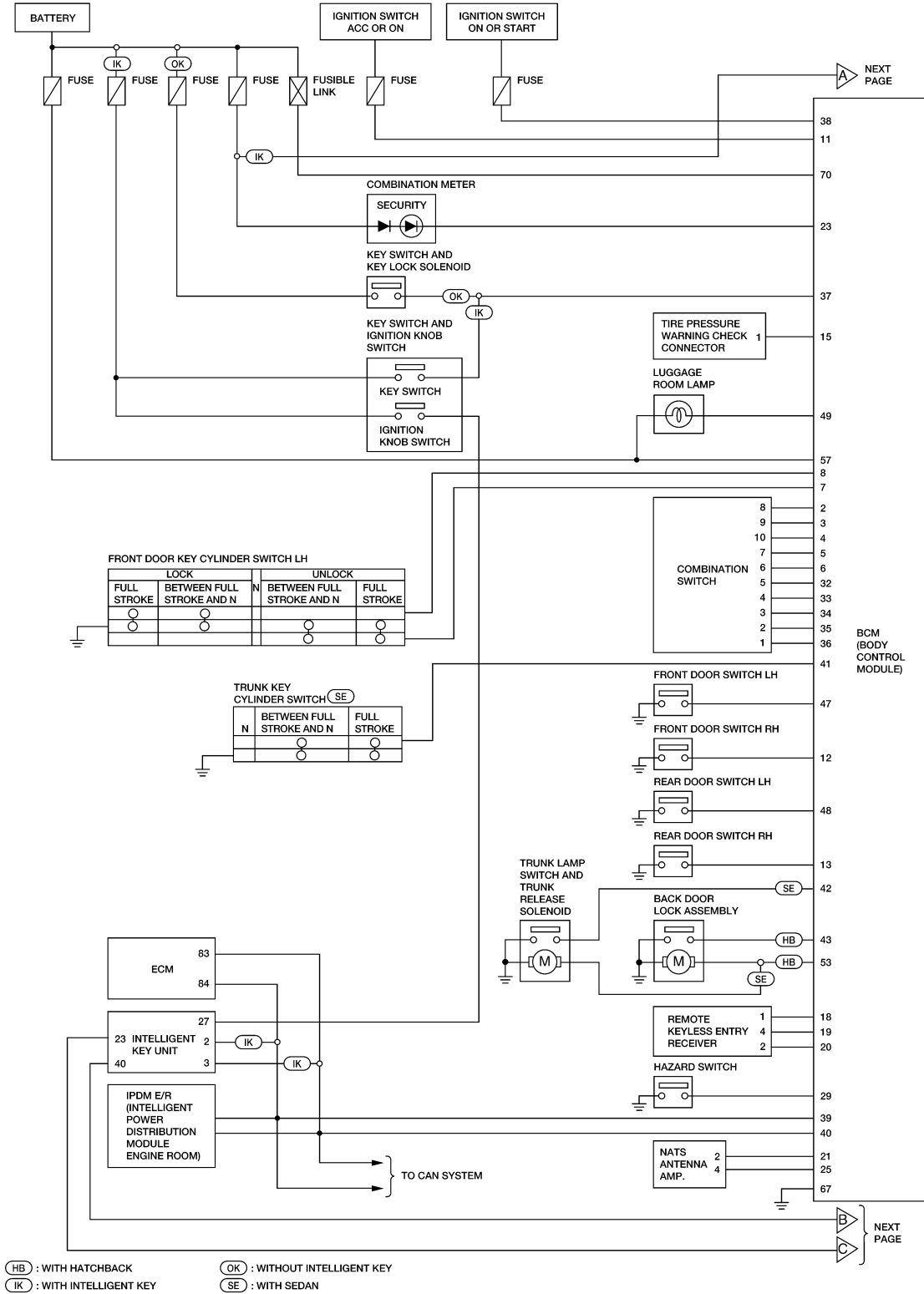

ALMWA0121Gf

BCM (BODY CONTROL MODULE)

< SERVICE INFORMATION >

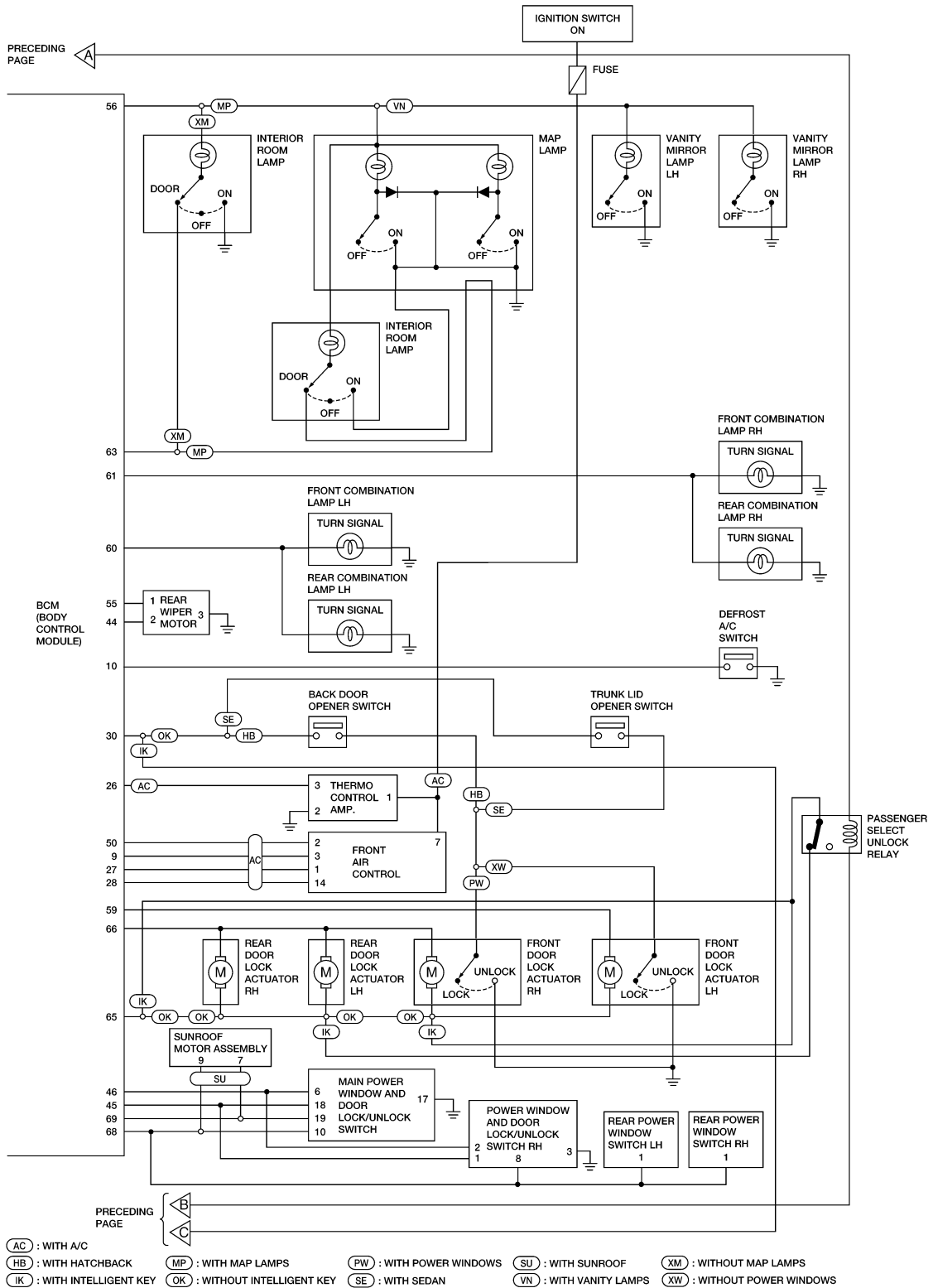

A
B
C
D
E
F
G
H
I
J
K
L
M
N
O
P

BCS

ALMWA0122GE

BCM (BODY CONTROL MODULE)

< SERVICE INFORMATION >

BCM Terminal Arrangement

INFOID:000000001704587

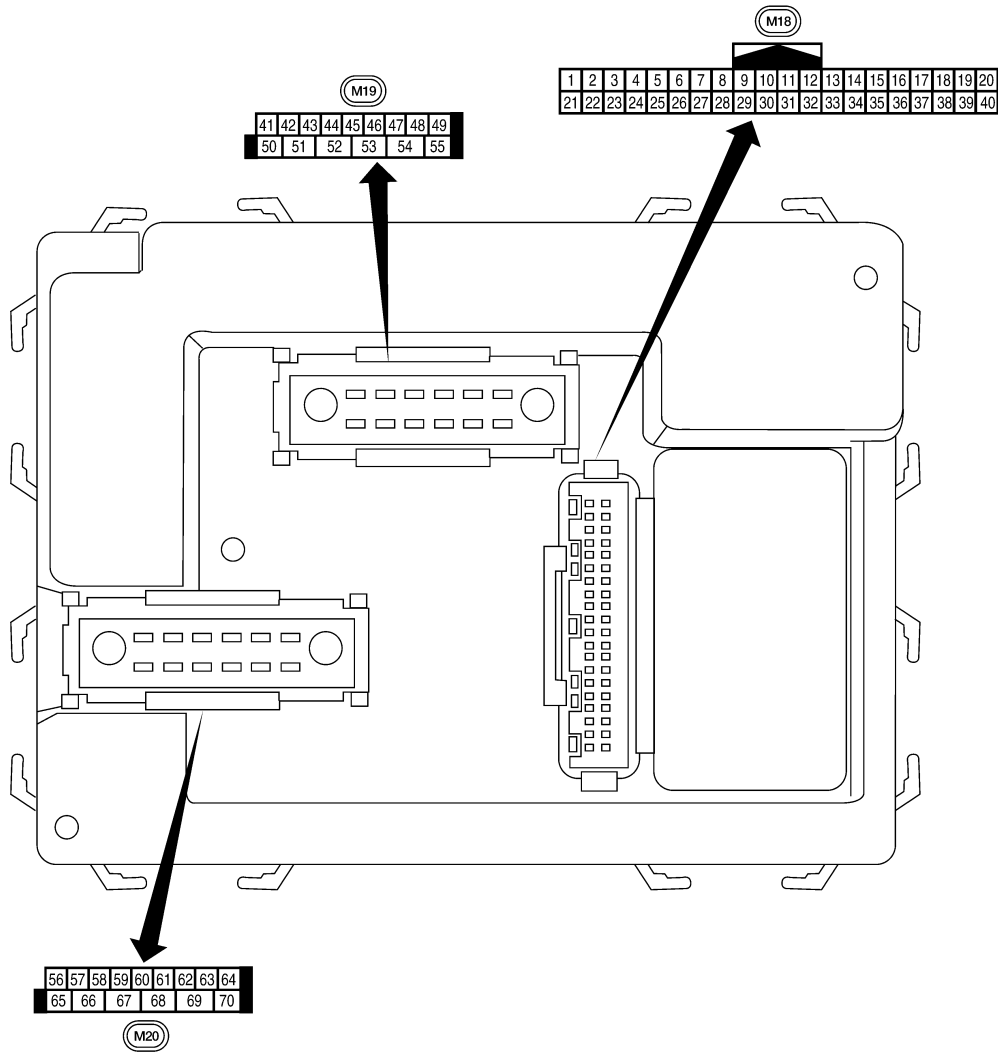

LIA2443E

BCM (BODY CONTROL MODULE)

< SERVICE INFORMATION >

Terminal and Reference Value for BCM

INFOID:000000001704588

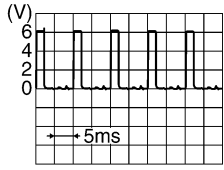
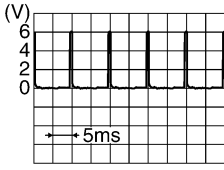
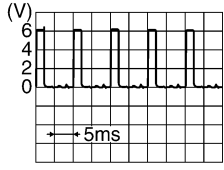
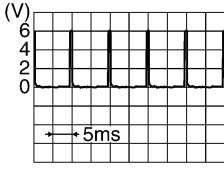
Terminal	Wire color	Signal name	Signal input/output	Measuring condition		Reference value or waveform (Approx.)
				Ignition switch	Operation or condition	
2	BR	Combination switch input 5	Input	ON	Lighting, turn, wiper OFF Wiper dial position 4	 <p style="text-align: right;">SKIA5291E</p>
3	GR	Combination switch input 4	Input	ON	Lighting, turn, wiper OFF Wiper dial position 4	 <p style="text-align: right;">SKIA5292E</p>
4	L	Combination switch input 3	Input	ON	Lighting, turn, wiper OFF Wiper dial position 4	 <p style="text-align: right;">SKIA5291E</p>
5	G	Combination switch input 2	Input	ON	Lighting, turn, wiper OFF Wiper dial position 4	 <p style="text-align: right;">SKIA5292E</p>
6	V	Combination switch input 1				
7	BR	Front door key cylinder switch LH (unlock)	Input	OFF	ON (open, 2nd turn)	Momentary 1.5V
8	Y	Front door key cylinder switch LH (lock)			On (open)	Momentary 1.5V
9	W	Rear window defogger switch	Input	ON	Rear window defogger switch ON	0V
					Rear window defogger switch OFF	5V
11	L	Ignition switch (ACC or ON)	Input	ACC or ON	Ignition switch ACC or ON	Battery voltage
12	SB	Front door switch RH	Input	OFF	ON (open)	0V
					OFF (closed)	Battery voltage
13	GR	Rear door switch RH	Input	OFF	ON (open)	0V
					OFF (closed)	Battery voltage
15	W	Tire pressure warning check connector	Input	OFF	—	5V

A

B

C

D

E

F

G

H

I

J

BCS

L

M

N

O

P

BCM (BODY CONTROL MODULE)

< SERVICE INFORMATION >

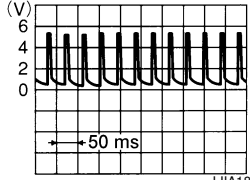
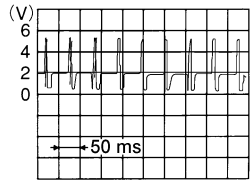
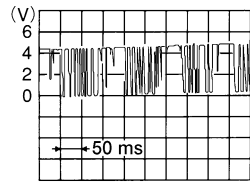
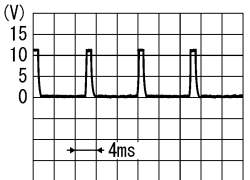
Terminal	Wire color	Signal name	Signal input/output	Measuring condition		Reference value or waveform (Approx.)
				Ignition switch	Operation or condition	
18	V	Remote keyless entry receiver (ground)	Output	OFF	—	0V
19	BR	Remote keyless entry receiver (power supply)	Output	OFF	Ignition switch OFF	 LIA1893E
20	G	Remote keyless entry receiver signal (signal)	Input	OFF	Stand-by (keyfob buttons released)	 LIA1894E
					When remote keyless entry receiver receives signal from keyfob (keyfob buttons pressed)	 LIA1895E
21	P	NATS antenna amp.	Input/Output	OFF → ON	Ignition switch (OFF → ON)	Just after turning ignition switch ON: Pointer of tester should move for approx. 1 second, then return to battery voltage.
23	R	Security indicator lamp	Output	OFF	Goes OFF → illuminates (Every 2.4 seconds)	Battery voltage → 0V
25	LG	NATS antenna amp.	Input/Output	OFF → ON	Ignition switch (OFF → ON)	Just after turning ignition switch ON: Pointer of tester should move for approx. 1 second, then return to battery voltage.
26	GR	Thermo control amp.	Input	ON	A/C switch ON	 ZJIA0719J
27	O	Compressor ON signal	Input	ON	A/C switch OFF	5V
					A/C switch ON	0V
28	P	Front blower monitor	Input	ON	Front blower motor OFF	Battery voltage
					Front blower motor ON	0V
29	L	Hazard switch	Input	OFF	ON	0V
					OFF	5V

BCM (BODY CONTROL MODULE)

< SERVICE INFORMATION >

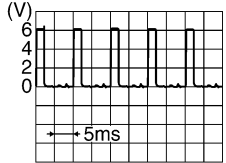
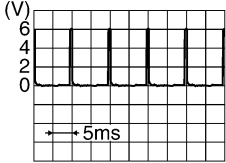
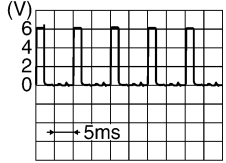
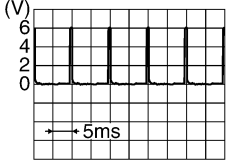
Terminal	Wire color	Signal name	Signal input/output	Measuring condition		Reference value or waveform (Approx.)
				Ignition switch	Operation or condition	
30*1	V	Back door/trunk output	Output	—	Back door open (switch closed)	0V
					Back door closed (switch open)	5V
30*2	V	Back door opener switch	Input	—	All doors locked (SW OFF)	Battery voltage
					All doors unlocked (SW ON)	0V
30*3	V	Trunk lid opener switch	Input	—	All doors locked (SW OFF)	Battery voltage
					All doors unlocked (SW ON)	0V
32	LG	Combination switch output 5	Output	ON	Lighting, turn, wiper OFF Wiper dial position 4	 <p style="text-align: right; font-size: small;">SKIA5291E</p>
33	Y	Combination switch output 4	Output	ON	Lighting, turn, wiper OFF Wiper dial position 4	 <p style="text-align: right; font-size: small;">SKIA5292E</p>
34	V	Combination switch output 3	Output	ON	Lighting, turn, wiper OFF Wiper dial position 4	 <p style="text-align: right; font-size: small;">SKIA5291E</p>
35	R	Combination switch output 2	Output	ON	Lighting, turn, wiper OFF Wiper dial position 4	 <p style="text-align: right; font-size: small;">SKIA5292E</p>
36	P	Combination switch output 1				
37	G	Key switch	Input	OFF	Key inserted	Battery voltage
					Key removed	0V
38	W	Ignition switch (ON)	Input	ON	—	Battery voltage
39	L	CAN-H	—	—	—	—
40	P	CAN-L	—	—	—	—
41*5	W	Trunk key cylinder switch	Input	—	ON (Full unlock position)	0V
					OFF (Neutral position)	5V
42	Y	Trunk lamp switch	Input	OFF	ON (trunk open)	0V
					OFF (trunk closed)	Battery voltage
43	R	Back door switch	Input	OFF	ON (open)	0V
					OFF (closed)	Battery voltage

A
B
C
D
E
F
G
H
I
J
L
M
N
O
P

BCS

BCM (BODY CONTROL MODULE)

< SERVICE INFORMATION >

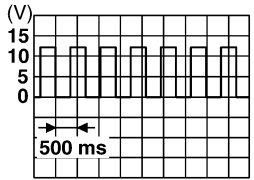
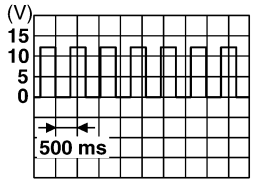
Terminal	Wire color	Signal name	Signal input/output	Measuring condition		Reference value or waveform (Approx.)	
				Ignition switch	Operation or condition		
44	LG	Rear wiper auto stop	Input	ON	Rear wiper operating	0	
					Rear wiper stopped	Battery	
45	GR	Lock switch	Input	OFF	ON (lock)	0V	
					OFF	Battery voltage	
46	L	Unlock switch	Input	OFF	ON (unlock)	0V	
					OFF	Battery voltage	
47	BR	Front door switch LH	Input	OFF	ON (open)	0V	
					OFF (closed)	Battery voltage	
48	O	Rear door switch LH	Input	OFF	ON (open)	0V	
					OFF (closed)	Battery voltage	
49	P	Luggage room lamp	Output	OFF	Any door open (ON)	0V	
					All doors closed (OFF)	Battery voltage	
50	SB	A/C indicator	Output	ON	A/C OFF	0	
					A/C ON	Battery voltage	
53 ^{*4}	R	Back door lock assembly (actuator)	Output	OFF	Back door (open)	Battery voltage	
53 ^{*5}	R	Trunk lamp switch and trunk release solenoid	Output	OFF	Trunk lid (open)	Battery voltage	
55	V	Rear wiper motor output	Output	ON	OFF	0	
					ON	Battery voltage	
56	R	Battery saver output	Output	OFF	30 minutes after ignition switch is turned OFF	0V	
				ON	—	Battery voltage	
57	LG	Battery power supply	Input	OFF	—	Battery voltage	
59	G	Front door lock actuator LH (unlock)	Output	OFF	OFF (neutral)	0V	
					ON (unlock)	Battery voltage	
60	V	Turn signal (left)	Output	ON	Turn left ON		
61	W	Turn signal (right)	Output	ON	Turn right ON		
63	BR	Interior room lamp	Output	OFF	Any door switch	ON (open)	0V
					OFF (closed)	Battery voltage	
65	SB	All door lock actuators (lock)	Output	OFF	OFF (neutral)	0V	
					ON (lock)	Battery voltage	

BCM (BODY CONTROL MODULE)

< SERVICE INFORMATION >

Terminal	Wire color	Signal name	Signal input/output	Measuring condition		Reference value or waveform (Approx.)
				Ignition switch	Operation or condition	
66	G	Front door lock actuator RH, rear door lock actuators LH/RH (unlock)	Output	OFF	OFF (neutral)	0V
					ON (unlock)	Battery voltage
67	B	Ground	Input	ON	—	0V
68	L	Power window power supply (RAP)	Output	—	Ignition switch ON	Battery voltage
					Within 45 seconds after ignition switch OFF	Battery voltage
					More than 45 seconds after ignition switch OFF	0V
					When front door LH or RH is open or power window timer operates	0V
69	P	Battery power supply	Output	OFF	—	Battery voltage
70	Y	Battery power supply	Input	OFF	—	Battery voltage

*1: With Intelligent Key

*2: Hatchback without Intelligent Key

*3: Sedan without Intelligent Key

*4: Hatchback

*5: Sedan

BCM Power Supply and Ground Circuit Inspection

INFOID:000000001704589

1. CHECK FUSES AND FUSIBLE LINK

- Check 40A fusible link (letter **g**, located in the fuse and fusible link box).
- Check 10A fuses [No. 6, 8 and 20, located in the fuse block (J/B)].

OK or NG

OK >> GO TO 2.

NG >> If fuse is blown, be sure to eliminate cause of malfunction before installing new fuse. Refer to [PG-3](#).

2. CHECK BCM POWER SUPPLY CIRCUIT

1. Turn ignition switch OFF.
2. Disconnect BCM.
3. Check voltage between BCM connectors and ground.

Connector	Terminals		Power source	Condition	Voltage (V) (Approx.)
	(+)	(-)			
M18	11	Ground	ACC power supply	Ignition switch ACC or ON	Battery voltage
	38	Ground	Ignition power supply	Ignition switch ON or START	Battery voltage
M20	57	Ground	Battery power supply	Ignition switch OFF	Battery voltage
	70	Ground	Battery power supply	Ignition switch OFF	Battery voltage

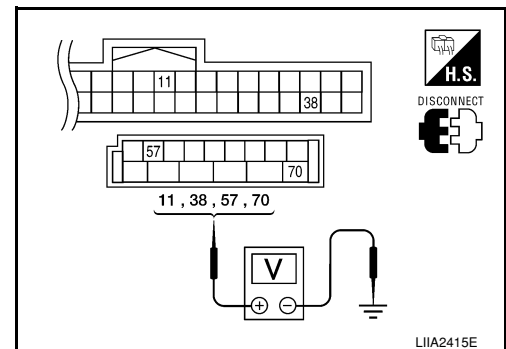

OK or NG

BCM (BODY CONTROL MODULE)

< SERVICE INFORMATION >

- OK >> GO TO 3.
 NG >> Repair or replace the harness.

3. CHECK GROUND CIRCUIT

Check continuity between BCM connector M20 terminal 67 and ground.

67 - Ground : Continuity should exist.

OK or NG

- OK >> Power supply and ground circuit is OK.
 NG >> Repair or replace harness.

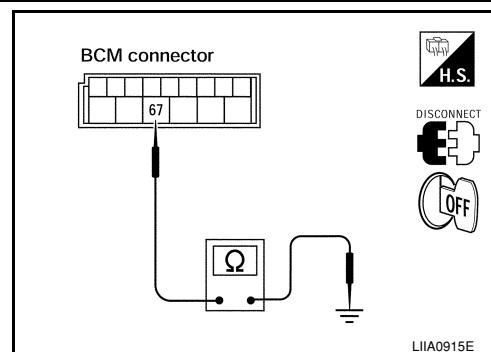

CONSULT-III Function (BCM)

INFOID:000000001704590

CONSULT-III can display each diagnostic item using the diagnostic test modes shown following.

BCM diagnostic test item	Diagnostic mode	Content
Inspection by part	WORK SUPPORT	Supports inspections and adjustments. Commands are transmitted to the BCM for setting the status suitable for required operation, input/output signals are received from the BCM and received data is displayed.
	DATA MONITOR	Displays BCM input/output data in real time.
	ACTIVE TEST	Operation of electrical loads can be checked by sending drive signal to them.
	SELF-DIAG RESULTS	Displays BCM self-diagnosis results.
	CAN DIAG SUPPORT MNTR	The results of transmit/receive diagnosis of CAN communication can be read.
	ECU PART NUMBER	BCM part number can be read.
	CONFIGURATION	Performs BCM configuration read/write functions.

ITEMS OF EACH PART

NOTE:

CONSULT-III will only display systems the vehicle possesses.

System and item	CONSULT-III display	Diagnostic test mode (Inspection by part)						
		WORK SUPPORT	SELF-DIAG RESULTS	CAN DIAG SUPPORT MNTR	DATA MONITOR	ECU PART NUMBER	ACTIVE TEST	CONFIGURATION
BCM	BCM	×	×	×		×		×
Power door lock system	DOOR LOCK	×			×		×	
Rear defogger	REAR DEFOGGER				×		×	
Warning chime	BUZZER				×		×	
Room lamp timer	INT LAMP	×			×		×	
Remote keyless entry system	MULTI REMOTE ENT	×			×		×	
Headlamp	HEAD LAMP	×			×		×	
Wiper	WIPER	×			×		×	
Turn signal lamp Hazard lamp	FLASHER				×		×	

BCM (BODY CONTROL MODULE)

< SERVICE INFORMATION >

System and item	CONSULT-III display	Diagnostic test mode (Inspection by part)						
		WORK SUPPORT	SELF-DIAG RESULTS	CAN DIAG SUPPORT MNTR	DATA MONITOR	ECU PART NUMBER	ACTIVE TEST	CONFIGURATION
Blower fan switch signal Air conditioner switch signal	AIR CONDITIONER				×			
Intelligent Key	INTELLIGENT KEY				×			
Combination switch	COMB SW				×			
NVIS (NATS)	IMMU				×		×	
Interior lamp battery saver	BATTERY SAVER	×			×		×	
Back door/Trunk	TRUNK				×		×	
Theft alarm	THEFT ALARM	×			×		×	
Retained accessory power control	RETAINED PWR	×			×		×	
Oil pressure switch	SIGNAL BUFFER				×		×	
Low tire pressure monitor	AIR PRESSURE MONITOR	×	×		×		×	
Panic alarm	PANIC ALARM						×	

WORK SUPPORT

Display Item List

Item	Description
RESET SETTING VALUE	Return a value set with WORK SUPPORT of each system to a default value in factory shipment.

CAN Communication Inspection Using CONSULT-III (Self-Diagnosis)

INFOID:000000001704591

1. SELF-DIAGNOSTIC RESULT CHECK

1. Connect CONSULT-III and select "BCM" on "SELECT SYSTEM" screen.
2. Select "BCM" on "SELECT TEST ITEM" screen, and select "SELF-DIAG RESULTS".
3. Check display content in self-diagnostic results.

CONSULT-III display code	Diagnosis item
U1000	INITIAL DIAG
	TRANSMIT DIAG
	ECM
	IPDM E/R
	METER/M&A
	I-KEY

Contents displayed

No malfunction>>Inspection End

Malfunction in CAN communication system>>After printing the monitor items, go to "CAN System". Refer to [LAN-15. "Trouble Diagnosis Flow Chart"](#).

Configuration

INFOID:000000001806223

DESCRIPTION

CONFIGURATION has three functions as follows:

- READ CONFIGURATION is the function to read (extract) vehicle configuration of current BCM.

BCM (BODY CONTROL MODULE)

< SERVICE INFORMATION >

- WRITE CONFIGURATION-Manual selection is the function to select and write vehicle configuration on BCM manually.
- WRITE CONFIGURATION-Config file is the function to write vehicle configuration with the data extracted from current BCM.
- For READ CONFIGURATION and WRITE CONFIGURATION-Config file, refer to CONSULT-III Operation Manual.
- For WRITE CONFIGURATION-Manual selection using the following flow chart, identify the correct model and configuration list. Confirm and/or change setting value for each item according to the configuration list. Depending on CONSULT-III software version being used, some or all of the write configuration items shown in the following configuration lists may be displayed. If an item does not appear on the CONSULT-III WRITE CONFIGURATION-Manual selection screen(s), then it is an auto setting item and it cannot be manually set or changed.

NOTE:

Confirm vehicle model on IDENTIFICATION PLATE. Refer to [GI-43, "Model Variation"](#).

ITEM	SET VAL
KEYLESS ENTRY	WITH ⇔ WITHOUT
I-KEY	WITH ⇔ WITHOUT
DTRL	WITH ⇔ WITHOUT
THEFT ALARM	WITH ⇔ WITHOUT

CAUTION:

- When replacing BCM, you must perform WRITE CONFIGURATION with CONSULT-III.
- Complete the procedure of WRITE CONFIGURATION in order.
- If you set incorrect WRITE CONFIGURATION, incidents will occur.
- Configuration is different for each vehicle model. Confirm configuration of each vehicle model.

Removal and Installation of BCM

INFOID:000000001704593

REMOVAL

1. Remove the glove box. Refer to [IP-11, "Removal and Installation"](#).
2. Remove the BCM screws, disconnect the connectors and remove the BCM (1).

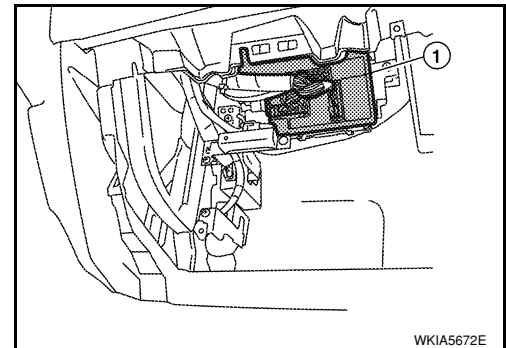

WKIA5672E

INSTALLATION

Installation is in the reverse order of removal.

NOTE:

- When replacing BCM, it must be configured. Refer to [BCS-17, "Configuration"](#).
- When replacing BCM, perform initialization of NATS system and registration of all NATS ignition key IDs. Refer to [BL-210](#).
- When replacing BCM, if new BCM does not come with keyfobs attached, all existing keyfobs must be re-registered.