

# SECTION **BL**

## BODY, LOCK & SECURITY SYSTEM

A  
B  
C  
D  
E  
F  
G  
H  
I  
J  
K  
L  
M

### CONTENTS

<b>PRECAUTIONS</b> .....	<b>4</b>	<b>INPUT</b> .....	<b>17</b>
Precautions for Supplemental Restraint System (SRS) "AIR BAG" and "SEAT BELT PRE-TENSIONER" .....	4	<b>OUTPUT</b> .....	18
Precautions for work .....	4	<b>OPERATION</b> .....	19
<b>PREPARATION</b> .....	<b>5</b>	Schematic .....	20
Special service tool .....	5	Wiring Diagram — D/LOCK — .....	21
Commercial Service Tool .....	5	Terminals and Reference Value for BCM .....	25
<b>SQUEAK AND RATTLE TROUBLE DIAGNOSES</b> .....	<b>6</b>	Work Flow .....	25
Work Flow .....	6	CONSULT-II Function (BCM) .....	26
CUSTOMER INTERVIEW .....	6	CONSULT-II INSPECTION PROCEDURE .....	26
DUPLICATE THE NOISE AND TEST DRIVE .....	7	WORK SUPPORT .....	27
CHECK RELATED SERVICE BULLETINS .....	7	DATA MONITOR .....	27
LOCATE THE NOISE AND IDENTIFY THE ROOT CAUSE .....	7	ACTIVE TEST .....	27
REPAIR THE CAUSE .....	7	Trouble Diagnoses Symptom Chart .....	28
CONFIRM THE REPAIR .....	8	BCM Power Supply and Ground Circuit Check .....	28
Generic Squeak and Rattle Troubleshooting .....	8	Door Switch Check .....	29
INSTRUMENT PANEL .....	8	Key Switch (Insert) Check .....	32
CENTER CONSOLE .....	8	Door Lock/Unlock Switch Check .....	33
DOORS .....	8	Front Door Lock Assembly LH (Actuator) Check ...	36
TRUNK .....	9	Front Door Lock Actuator RH Check .....	37
SUNROOF/HEADLINING .....	9	Back Door Lock Actuator and Rear Door Lock Actuator RH/LH Check .....	38
OVERHEAD CONSOLE (FRONT AND REAR).....	9	FrontDoorLockAssemblyLH(KeyCylinderSwitch) Check .....	39
SEATS .....	9	Back Door Key Cylinder Switch Check .....	41
UNDERHOOD .....	9	<b>REMOTE KEYLESS ENTRY SYSTEM</b> .....	<b>43</b>
Diagnostic Worksheet .....	10	Component Parts and Harness Connector Location..	43
<b>HOOD</b> .....	<b>12</b>	System Description .....	44
Fitting Adjustment .....	12	INPUTS .....	44
CLEARANCE AND SURFACE HEIGHT ADJUSTMENT .....	12	OPERATED PROCEDURE .....	44
HOOD LOCK ADJUSTMENT .....	13	CAN Communication System Description .....	46
Removal and Installation of Hood Assembly .....	13	Schematic .....	47
Removal and Installation of Hood Lock Control ...	14	Wiring Diagram — KEYLES — .....	48
REMOVAL .....	14	Terminals and Reference Value for BCM .....	51
INSTALLATION .....	14	Terminals and Reference Value for IPDM E/R .....	51
Hood Lock Control Inspection .....	15	CONSULT-II Function (BCM) .....	51
<b>POWER DOOR LOCK SYSTEM</b> .....	<b>16</b>	CONSULT-II Inspection Procedure .....	51
Component Parts and Harness Connector Location..	16	"MULTI REMOTE ENT" .....	51
System Description .....	16	CONSULT-II Application Items .....	52
		"MULTI REMOTE ENT" .....	52
		Trouble Diagnosis Procedure .....	55

**BL**

Pre-Diagnosis Inspection .....	55	Component Structure .....	97
BCMPowerSupplyAndGroundCircuit		Removal and Installation .....	97
INSPECTION .....	55	REMOVAL .....	97
Trouble Diagnoses .....	55	INSTALLATION .....	99
SYMPTOM CHART .....	55	Disassembly and Assembly .....	99
Key Switch (Insert) Check .....	57	DOOR KEY CYLINDER ASSEMBLY .....	99
Door Switch Check .....	58	<b>REAR DOOR LOCK .....</b>	<b>100</b>
Keyfob Battery and Function Check .....	60	Component Structure .....	100
Remote Keyless Entry Receiver System Check ....	61	Removal and Installation .....	100
ACC Power Check .....	63	REMOVAL .....	100
IPDM E/R Operation Check .....	63	INSTALLATION .....	100
Check Hazard Function .....	64	<b>BACK DOOR LOCK .....</b>	<b>101</b>
Check Horn Function .....	64	Component Structure .....	101
Check Headlamp Function .....	64	<b>NVIS(NISSAN VEHICLE IMMOBILIZER SYSTEM-</b>	
Check Room Lamp Illumination Function .....	64	<b>NATS) .....</b>	<b>102</b>
ID Code Entry Procedure .....	65	Component Parts and Harness Connector Location	102
KEYFOB ID SET UP WITH CONSULT-II .....	65	System Description .....	103
KEYFOB ID SET UP WITHOUT CONSULT-II ....	67	System Composition .....	103
Keyfob Battery Replacement .....	68	ECM Re-communicating Function .....	104
<b>VEHICLE SECURITY (THEFT WARNING) SYSTEM.. 69</b>		Wiring Diagram — NATS — .....	105
Component Parts and Harness Connector Location..	69	Terminals and Reference Value for BCM .....	107
System Description .....	70	CONSULT-II .....	107
DESCRIPTION .....	70	CONSULT-II INSPECTION PROCEDURE .....	107
POWER SUPPLY AND GROUND CIRCUIT .....	70	CONSULT-II DIAGNOSTIC TEST MODE FUNC-	
INITIAL CONDITION TO ACTIVATE THE SYS-		TION .....	108
TEM .....	71	HOW TO READ SELF-DIAGNOSTIC RESULTS.	108
VEHICLE SECURITY SYSTEM ALARM OPER-		NVIS (NATS) SELF-DIAGNOSTIC RESULTS	
ATION .....	71	ITEM CHART .....	109
VEHICLE SECURITY SYSTEM DEACTIVATION..	71	Work Flow .....	110
PANIC ALARM OPERATION .....	71	Trouble Diagnoses .....	111
CAN Communication System Description .....	72	SYMPTOM MATRIX CHART 1 .....	111
Schematic .....	73	SYMPTOM MATRIX CHART 2 .....	112
Wiring Diagram — VEHSEC — .....	74	DIAGNOSTIC SYSTEM DIAGRAM .....	112
Terminals and Reference Value for BCM .....	79	Diagnostic Procedure 1 .....	113
Terminals and Reference Value for IPDM E/R .....	79	Diagnostic Procedure 2 .....	114
CONSULT-II Function (BCM) .....	79	Diagnostic Procedure 3 .....	115
CONSULT-II INSPECTION PROCEDURE .....	79	Diagnostic Procedure 4 .....	116
CONSULT-II APPLICATION ITEM .....	80	Diagnostic Procedure 5 .....	117
Trouble Diagnosis .....	81	Diagnostic Procedure 6 .....	120
WORK FLOW .....	81	How to Replace NATS Antenna Amp. ....	121
Preliminary Check .....	82	<b>CAB AND REAR BODY .....</b>	<b>122</b>
Symptom Chart .....	83	Body Mounting .....	122
Diagnostic Procedure 1 .....	84	<b>BODY REPAIR .....</b>	<b>123</b>
Diagnostic Procedure 2 .....	87	Body Exterior Paint Color .....	123
Diagnostic Procedure 3 .....	88	Body Component Parts .....	124
Diagnostic Procedure 4 .....	91	UNDERBODY COMPONENT PARTS .....	124
Diagnostic Procedure 5 .....	91	BODY COMPONENT PARTS .....	126
Diagnostic Procedure 6 .....	91	FRAME COMPONENT PARTS .....	128
<b>DOOR .....</b>	<b>92</b>	Corrosion Protection .....	130
Fitting Adjustment .....	92	DESCRIPTION .....	130
FRONT DOOR .....	92	ANTI-CORROSIVE WAX .....	131
REAR DOOR .....	92	UNDERCOATING .....	132
BACK DOOR .....	93	Body Sealing .....	133
STRIKER ADJUSTMENT .....	94	DESCRIPTION .....	133
Removal and Installation .....	94	Body Construction .....	136
FRONT DOOR .....	94	BODY CONSTRUCTION .....	136
REAR DOOR .....	95	Body Alignment .....	137
BACK DOOR .....	95	BODY CENTER MARKS .....	137
<b>FRONT DOOR LOCK .....</b>	<b>97</b>	PANEL PARTS MATCHING MARKS .....	138

DESCRIPTION .....	139	FILL PROCEDURES .....	156
ENGINE COMPARTMENT .....	140	Replacement Operations .....	157
UNDERBODY .....	142	DESCRIPTION .....	157
PASSENGER COMPARTMENT .....	145	HOODLEDGE .....	160
REAR BODY .....	149	FRONT PILLAR .....	162
Handling Precautions for Plastics .....	151	CENTER PILLAR .....	163
HANDLING PRECAUTIONS FOR PLASTICS ..	151	OUTER SILL .....	165
LOCATION OF PLASTIC PARTS .....	152	REAR FENDER .....	166
Precautions in Repairing High Strength Steel .....	154	REAR FENDER EXTENSION .....	167
HIGH STRENGTH STEEL (HSS) USED IN NIS-		MAIN BACK PILLAR .....	168
SAN VEHICLES .....	154	REAR FLOOR REAR .....	169
Foam Repair .....	156	REAR CROSSMEMBER .....	170
URETHANE FOAM APPLICATIONS .....	156	CRUSH HORN .....	172

A  
B  
C  
D  
E  
F  
G  
H  
J  
K  
L  
M

**BL**

# PRECAUTIONS

## PRECAUTIONS

PF0:00001

### Precautions for Supplemental Restraint System (SRS) “AIR BAG” and “SEAT BELT PRE-TENSIONER”

EIS0063D

The Supplemental Restraint System such as “AIR BAG” and “SEAT BELT PRE-TENSIONER”, used along with a front seat belt, helps to reduce the risk or severity of injury to the driver and front passenger for certain types of collision. This system includes seat belt switch inputs and dual stage front air bag modules. The SRS system uses the seat belt switches to determine the front air bag deployment, and may only deploy one front air bag, depending on the severity of a collision and whether the front occupants are belted or unbelted. Information necessary to service the system safely is included in the SRS and SB section of this Service Manual.

#### **WARNING:**

- To avoid rendering the SRS inoperative, which could increase the risk of personal injury or death in the event of a collision which would result in air bag inflation, all maintenance must be performed by an authorized NISSAN/INFINITI dealer.
- Improper maintenance, including incorrect removal and installation of the SRS, can lead to personal injury caused by unintentional activation of the system. For removal of Spiral Cable and Air Bag Module, see the SRS section.
- Do not use electrical test equipment on any circuit related to the SRS unless instructed to in this Service Manual. SRS wiring harnesses can be identified by yellow and/or orange harnesses or harness connectors.

#### Precautions for work

EIS0063E

- After removing and installing the opening/closing parts, be sure to carry out fitting adjustments to check their operation.
- Check the lubrication level, damage, and wear of each part. If necessary, grease or replace it.

# PREPARATION

## PREPARATION

PPF:00002

### Special service tool

EIS0063G

The actual shapes of Kent-Moore tools may differ from those of special service tools illustrated here.

Tool number (Kent-Moore No.) Tool name	Description
— (J-39570) Chassis ear	Locating the noise
— (J-43980) NISSAN Squeak and Rattle Kit	Repairing the cause of noise
— (J-43241) Remote Keyless Entry Tester	Testing keyfobs

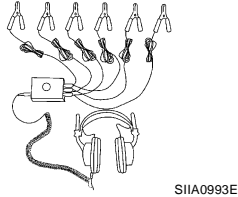

SIIA0993E

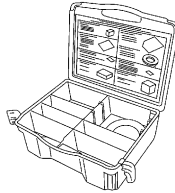

SIIA0994E

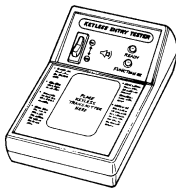

LEL946A

## Commercial Service Tool

EIS0063H

(Kent-Moore No.) Tool name	Description
(J-39565) Engine ear	Locating the noise

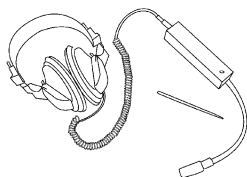

SIIA0995E

A  
B  
C  
D  
E  
F  
G  
H  
BL  
J  
K  
L  
M

# SQUEAK AND RATTLE TROUBLE DIAGNOSES

## SQUEAK AND RATTLE TROUBLE DIAGNOSES

PF0:0000

### Work Flow

EIS0063I

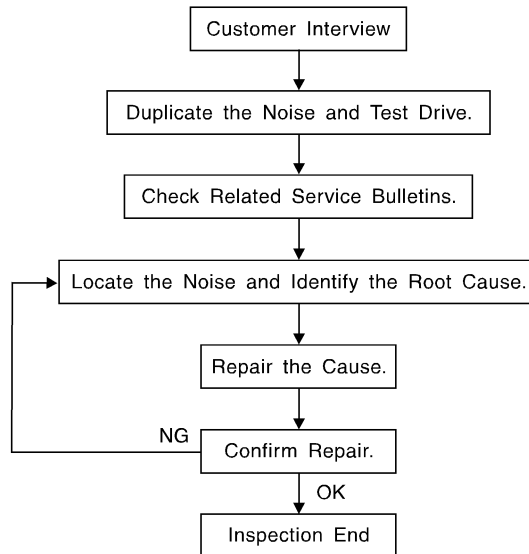

SBT842

### CUSTOMER INTERVIEW

Interview the customer if possible, to determine the conditions that exist when the noise occurs. Use the Diagnostic Worksheet during the interview to document the facts and conditions when the noise occurs and any customer's comments; refer to [GW-9, "Diagnostic Worksheet"](#). This information is necessary to duplicate the conditions that exist when the noise occurs.

- The customer may not be able to provide a detailed description or the location of the noise. Attempt to obtain all the facts and conditions that exist when the noise occurs (or does not occur).
- If there is more than one noise in the vehicle, be sure to diagnose and repair the noise that the customer is concerned about. This can be accomplished by test driving the vehicle with the customer.
- After identifying the type of noise, isolate the noise in terms of its characteristics. The noise characteristics are provided so the customer, service adviser and technician are all speaking the same language when defining the noise.
- Squeak —(Like tennis shoes on a clean floor)  
Squeak characteristics include the light contact/fast movement/brought on by road conditions/hard surfaces = higher pitch noise/softer surfaces = lower pitch noises/edge to surface = chirping.
- Creak—(Like walking on an old wooden floor)  
Creak characteristics include firm contact/slow movement/twisting with a rotational movement/pitch dependent on materials/often brought on by activity.
- Rattle—(Like shaking a baby rattle)  
Rattle characteristics include the fast repeated contact/vibration or similar movement/loose parts/missing clip or fastener/incorrect clearance.
- Knock —(Like a knock on a door)  
Knock characteristics include hollow sounding/sometimes repeating/often brought on by driver action.
- Tick—(Like a clock second hand)  
Tick characteristics include gentle contacting of light materials/loose components/can be caused by driver action or road conditions.
- Thump—(Heavy, muffled knock noise)  
Thump characteristics include softer knock/dead sound often brought on by activity.
- Buzz—(Like a bumble bee)  
Buzz characteristics include high frequency rattle/firm contact.
- Often the degree of acceptable noise level will vary depending upon the person. A noise that you may judge as acceptable may be very irritating to the customer.
- Weather conditions, especially humidity and temperature, may have a great effect on noise level.

# SQUEAK AND RATTLE TROUBLE DIAGNOSES

## DUPLICATE THE NOISE AND TEST DRIVE

If possible, drive the vehicle with the customer until the noise is duplicated. Note any additional information on the Diagnostic Worksheet regarding the conditions or location of the noise. This information can be used to duplicate the same conditions when you confirm the repair.

If the noise can be duplicated easily during the test drive, to help identify the source of the noise, try to duplicate the noise with the vehicle stopped by doing one or all of the following:

- 1) Close a door.
  - 2) Tap or push/pull around the area where the noise appears to be coming from.
  - 3) Rev the engine.
  - 4) Use a floor jack to recreate vehicle "twist".
  - 5) At idle, apply engine load (electrical load, half-clutch on M/T model, drive position on A/T model).
  - 6) Raise the vehicle on a hoist and hit a tire with a rubber hammer.
- Drive the vehicle and attempt to duplicate the conditions the customer states exist when the noise occurs.
  - If it is difficult to duplicate the noise, drive the vehicle slowly on an undulating or rough road to stress the vehicle body.

## CHECK RELATED SERVICE BULLETINS

After verifying the customer concern or symptom, check ASIST for Technical Service Bulletins (TSBs) related to that concern or symptom.

If a TSB relates to the symptom, follow the procedure to repair the noise.

## LOCATE THE NOISE AND IDENTIFY THE ROOT CAUSE

1. Narrow down the noise to a general area. To help pinpoint the source of the noise, use a listening tool (Chassis Ear: J-39570, Engine Ear: J-39565 and mechanic's stethoscope).
2. Narrow down the noise to a more specific area and identify the cause of the noise by:
  - removing the components in the area that you suspect the noise is coming from. Do not use too much force when removing clips and fasteners, otherwise clips and fasteners can be broken or lost during the repair, resulting in the creation of new noise.
  - tapping or pushing/pulling the component that you suspect is causing the noise. Do not tap or push/pull the component with excessive force, otherwise the noise will be eliminated only temporarily.
  - feeling for a vibration with your hand by touching the component(s) that you suspect is (are) causing the noise.
  - placing a piece of paper between components that you suspect are causing the noise.
  - looking for loose components and contact marks.  
Refer to [GW-7, "Generic Squeak and Rattle Troubleshooting"](#).

## REPAIR THE CAUSE

- If the cause is a loose component, tighten the component securely.
- If the cause is insufficient clearance between components:
  - separate components by repositioning or loosening and retightening the component, if possible.
  - insulate components with a suitable insulator such as urethane pads, foam blocks, felt cloth tape or urethane tape. A NISSAN Squeak and Rattle Kit (J-43980) is available through your authorized NISSAN Parts Department.

### CAUTION:

**Do not use excessive force as many components are constructed of plastic and may be damaged.**

**Always check with the Parts Department for the latest parts information.**

**The following materials are contained in the NISSAN Squeak and Rattle Kit (J-43980). Each item can be ordered separately as needed.**

**URETHANE PADS [1.5 mm (0.059 in) thick]**

**Insulates connectors, harness, etc.**

**76268-9E005: 100×135 mm (3.94×5.31 in)/76884-71L01: 60×85 mm (2.36×3.35 in)/76884-71L02: 15×25 mm (0.59×0.98 in)**

**INSULATOR (Foam blocks)**

**Insulates components from contact. Can be used to fill space behind a panel.**

**73982-9E000: 45 mm (1.77 in) thick, 50×50 mm (1.97×1.97 in)/73982-50Y00: 10 mm (0.39 in) thick, 50×50 mm (1.97×1.97 in)**

**INSULATOR (Light foam block)**

# SQUEAK AND RATTLE TROUBLE DIAGNOSES

**80845-71L00: 30 mm (1.18 in) thick, 30×50 mm (1.18×1.97 in)**

## **FELT CLOTH TAPE**

Used to insulate where movement does not occur. Ideal for instrument panel applications.

**68370-4B000: 15×25 mm (0.59×0.98 in) pad/68239-13E00: 5 mm (0.20 in) wide tape roll.** The following materials not found in the kit can also be used to repair squeaks and rattles.

## **UHMW (TEFLON) TAPE**

Insulates where slight movement is present. Ideal for instrument panel applications.

## **SILICONE GREASE**

Used instead of UHMW tape that will be visible or not fit.

**Note: Will only last a few months.**

## **SILICONE SPRAY**

Use when grease cannot be applied.

## **DUCT TAPE**

Use to eliminate movement.

## **CONFIRM THE REPAIR**

Confirm that the cause of a noise is repaired by test driving the vehicle. Operate the vehicle under the same conditions as when the noise originally occurred. Refer to the notes on the Diagnostic Worksheet.

## **Generic Squeak and Rattle Troubleshooting**

E/S0063J

Refer to Table of Contents for specific component removal and installation information.

## **INSTRUMENT PANEL**

Most incidents are caused by contact and movement between:

1. The cluster lid A and instrument panel
2. Acrylic lens and combination meter housing
3. Instrument panel to front pillar garnish
4. Instrument panel to windshield
5. Instrument panel mounting pins
6. Wiring harnesses behind the combination meter
7. A/C defroster duct and duct joint

These incidents can usually be located by tapping or moving the components to duplicate the noise or by pressing on the components while driving to stop the noise. Most of these incidents can be repaired by applying felt cloth tape or silicone spray (in hard to reach areas). Urethane pads can be used to insulate wiring harness.

### **CAUTION:**

**Do not use silicone spray to isolate a squeak or rattle. If you saturate the area with silicone, you will not be able to recheck the repair.**

## **CENTER CONSOLE**

Components to pay attention to include:

1. Shifter assembly cover to finisher
2. A/C control unit and cluster lid C
3. Wiring harnesses behind audio and A/C control unit

The instrument panel repair and isolation procedures also apply to the center console.

## **DOORS**

Pay attention to the:

1. Finisher and inner panel making a slapping noise
2. Inside handle escutcheon to door finisher
3. Wiring harnesses tapping
4. Door striker out of alignment causing a popping noise on starts and stops

Tapping or moving the components or pressing on them while driving to duplicate the conditions can isolate many of these incidents. You can usually insulate the areas with felt cloth tape or insulator foam blocks from the NISSAN Squeak and Rattle Kit (J-43980) to repair the noise.



# SQUEAK AND RATTLE TROUBLE DIAGNOSES

## TRUNK

Trunk noises are often caused by a loose jack or loose items put into the trunk by the owner. In addition look for:

1. Trunk lid bumpers out of adjustment
2. Trunk lid striker out of adjustment
3. The trunk lid torsion bars knocking together
4. A loose license plate or bracket

Most of these incidents can be repaired by adjusting, securing or insulating the item(s) or component(s) causing the noise.

## SUNROOF/HEADLINING

Noises in the sunroof/headlining area can often be traced to one of the following:

1. Sunroof lid, rail, linkage or seals making a rattle or light knocking noise
2. Sun visor shaft shaking in the holder
3. Front or rear windshield touching headliner and squeaking

Again, pressing on the components to stop the noise while duplicating the conditions can isolate most of these incidents. Repairs usually consist of insulating with felt cloth tape.

## OVERHEAD CONSOLE (FRONT AND REAR)

Overhead console noises are often caused by the console panel clips not being engaged correctly. Most of these incidents are repaired by pushing up on the console at the clip locations until the clips engage.

In addition look for:

1. Loose harness or harness connectors.
2. Front console map/reading lamp lense loose.
3. Loose screws at console attachment points.

## SEATS

When isolating seat noise it's important to note the position the seat is in and the load placed on the seat when the noise is present. These conditions should be duplicated when verifying and isolating the cause of the noise.

Cause of seat noise include:

1. Headrest rods and holder
2. A squeak between the seat pad cushion and frame
3. The rear seatback lock and bracket

These noises can be isolated by moving or pressing on the suspected components while duplicating the conditions under which the noise occurs. Most of these incidents can be repaired by repositioning the component or applying urethane tape to the contact area.

## UNDERHOOD

Some interior noise may be caused by components under the hood or on the engine wall. The noise is then transmitted into the passenger compartment.

Causes of transmitted underhood noise include:

1. Any component mounted to the engine wall
2. Components that pass through the engine wall
3. Engine wall mounts and connectors
4. Loose radiator mounting pins
5. Hood bumpers out of adjustment
6. Hood striker out of adjustment

These noises can be difficult to isolate since they cannot be reached from the interior of the vehicle. The best method is to secure, move or insulate one component at a time and test drive the vehicle. Also, engine RPM or load can be changed to isolate the noise. Repairs can usually be made by moving, adjusting, securing, or insulating the component causing the noise.

A

B

C

D

E

F

G

H

BL

J

K

L

M

# SQUEAK AND RATTLE TROUBLE DIAGNOSES

## Diagnostic Worksheet

EIS0063K



### SQUEAK & RATTLE DIAGNOSTIC WORKSHEET

Dear Nissan Customer:

We are concerned about your satisfaction with your Nissan vehicle. Repairing a squeak or rattle sometimes can be very difficult. To help us fix your Nissan right the first time, please take a moment to note the area of the vehicle where the squeak or rattle occurs and under what conditions. You may be asked to take a test drive with a service advisor or technician to ensure we confirm the noise you are hearing.

#### I. WHERE DOES THE NOISE COME FROM? (circle the area of the vehicle)

The illustrations are for reference only, and may not reflect the actual configuration of your vehicle.

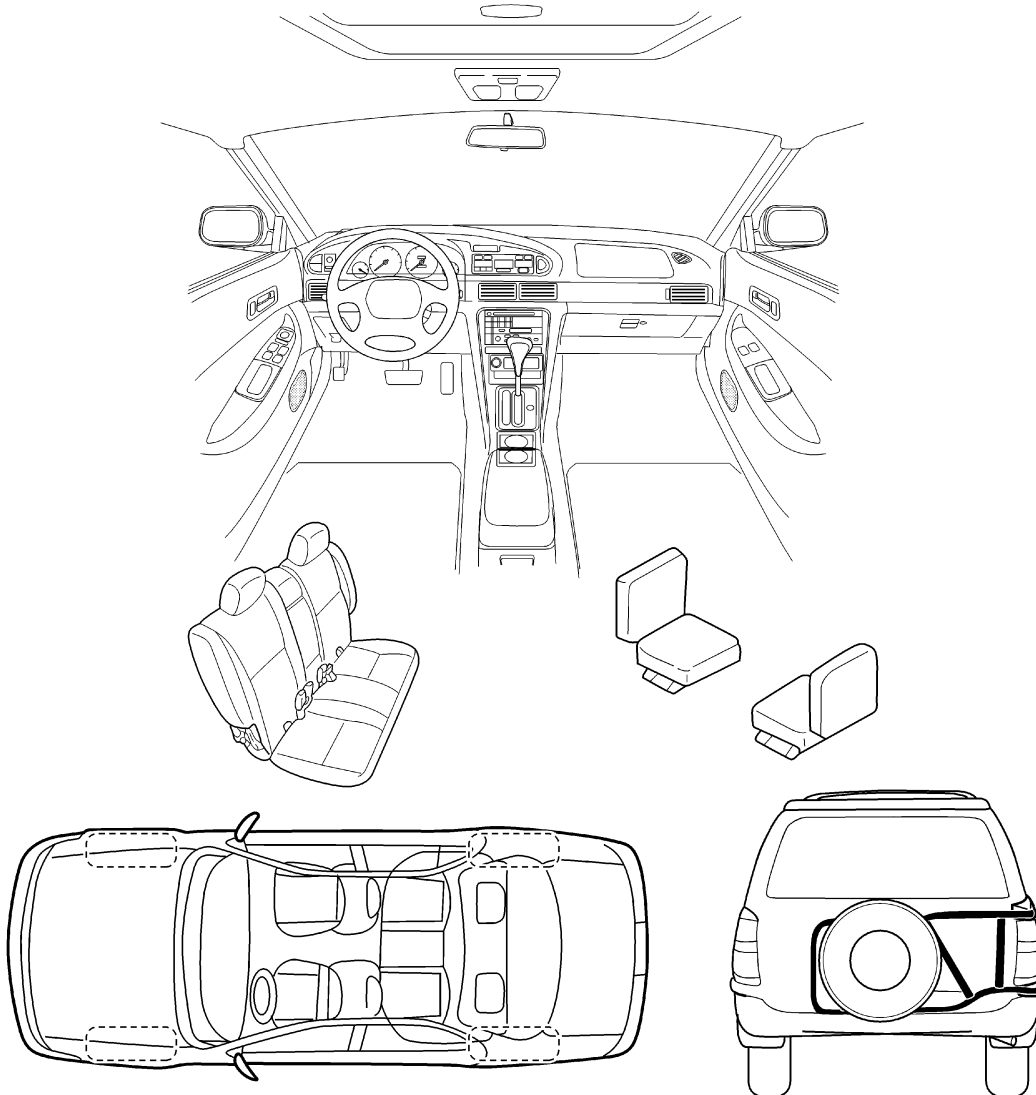

Continue to the back of the worksheet and briefly describe the location of the noise or rattle. In addition, please indicate the conditions which are present when the noise occurs.

LIWA0276E

# SQUEAK AND RATTLE TROUBLE DIAGNOSES

## SQUEAK & RATTLE DIAGNOSTIC WORKSHEET- page 2

Briefly describe the location where the noise occurs:

---

---

---

### II. WHEN DOES IT OCCUR? (check the boxes that apply)

- |  |   |
|--|---|
| <input type="checkbox"/> anytime                             | <input type="checkbox"/> after sitting out in the sun |
| <input type="checkbox"/> 1 <sup>st</sup> time in the morning | <input type="checkbox"/> when it is raining or wet    |
| <input type="checkbox"/> only when it is cold outside        | <input type="checkbox"/> dry or dusty conditions      |
| <input type="checkbox"/> only when it is hot outside         | <input type="checkbox"/> other: _____                 |

### III. WHEN DRIVING:

- through driveways
- over rough roads
- over speed bumps
- only at about \_\_\_\_ mph
- on acceleration
- coming to a stop
- on turns : left, right or either (circle)
- with passengers or cargo
- other: \_\_\_\_\_
- after driving \_\_\_\_ miles or \_\_\_\_ minutes

### IV. WHAT TYPE OF NOISE?

- squeak (like tennis shoes on a clean floor)
- creak (like walking on an old wooden floor)
- rattle (like shaking a baby rattle)
- knock (like a knock on a door)
- tick (like a clock second hand)
- thump (heavy, muffled knock noise)
- buzz (like a bumble bee)

### TO BE COMPLETED BY DEALERSHIP PERSONNEL

#### Test Drive Notes:

---

---

	<u>YES</u>	<u>NO</u>	Initials of person <u>performing</u>
Vehicle test driven with customer	<input type="checkbox"/>	<input type="checkbox"/>	_____
- Noise verified on test drive	<input type="checkbox"/>	<input type="checkbox"/>	_____
- Noise source located and repaired	<input type="checkbox"/>	<input type="checkbox"/>	_____
- Follow up test drive performed to confirm repair	<input type="checkbox"/>	<input type="checkbox"/>	_____

VIN: \_\_\_\_\_ Customer Name: \_\_\_\_\_

W.O. #: \_\_\_\_\_ Date: \_\_\_\_\_

SBT844

**This form must be attached to Work Order**

# HOOD

PFP:F5100

EIS0063L

## HOOD

### Fitting Adjustment

SEC.650

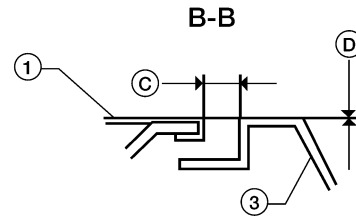
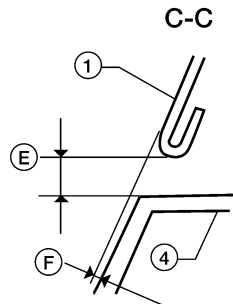
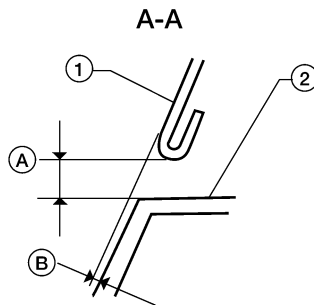
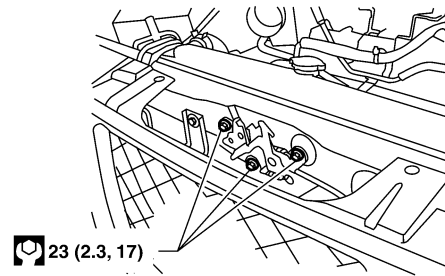
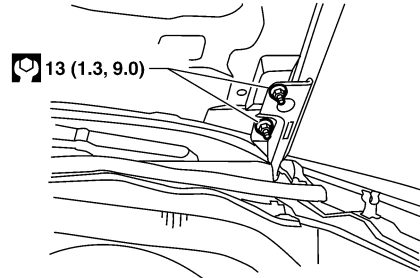
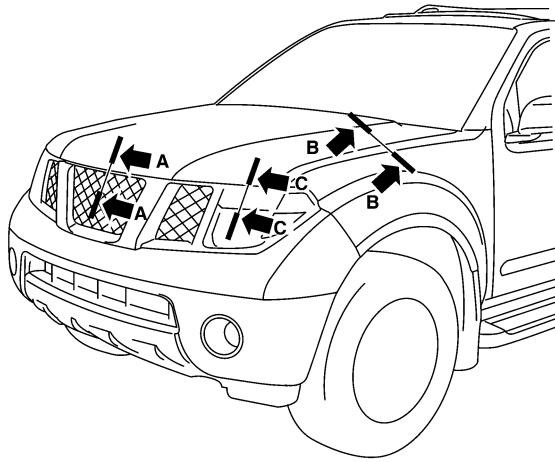

- |                      |                     |                     |
|----------------------|---------------------|---------------------|
| 1. Hood              | 2. Front grille     | 3. Front fender     |
| 4. Headlamp assembly | A. 6.0 mm (0.24 in) | B. 0.7 mm (0.03 in) |
| C. 4.5 mm (0.18 in)  | D. 0.0 mm (0.0 in)  | E. 6.0 mm (0.24 in) |
| F. 0.7 mm (0.03 in)  |                     |                     |

W1IA0774E

### CLEARANCE AND SURFACE HEIGHT ADJUSTMENT

1. Remove the front grille. Refer to [EI-16, "FRONT GRILLE"](#).
2. Loosen the hood lock and adjust the height by rotating the rubber bumpers until the surface height of the hood becomes 1 mm (0.04 in) lower than the fender.
3. Engage the hood striker and temporarily tighten.
4. Check the lock and striker for looseness.

# HOOD

5. Tighten the bolts to specification.
6. Adjust the surface height of the hood according to the fitting standard dimension by rotating right and left rubber bumpers.
7. Install the front grille. Refer to [EI-16, "FRONT GRILLE"](#).

## HOOD LOCK ADJUSTMENT

1. Remove the front grille. Refer to [EI-16, "FRONT GRILLE"](#).
2. Move the hood lock to the left or right so that striker center is vertically aligned with hood lock center (when viewed from vehicle front).
3. Make sure the secondary latch is properly engaged with the secondary striker with hood's own weight by dropping it from approx. 200 mm (7.87 in) height or by pressing it lightly approx. 3 kg (29 N, 7lb).

### CAUTION:

**Do not drop the hood from 300 mm (11.81 in) height or higher.**

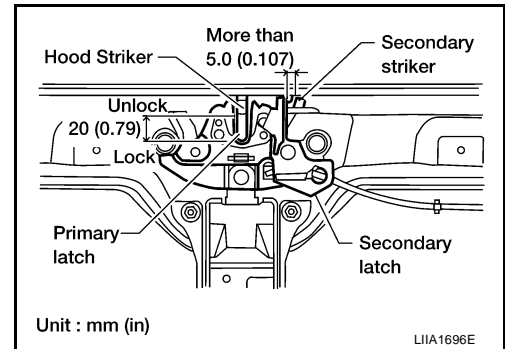

4. After adjusting hood lock, tighten the lock bolts to the specified torque.
5. Install the front grille. Refer to [EI-16, "FRONT GRILLE"](#).

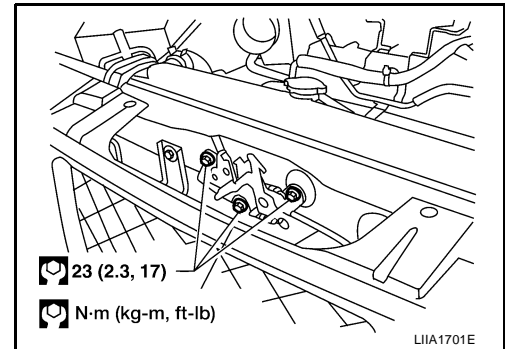

## Removal and Installation of Hood Assembly

EIS0063M

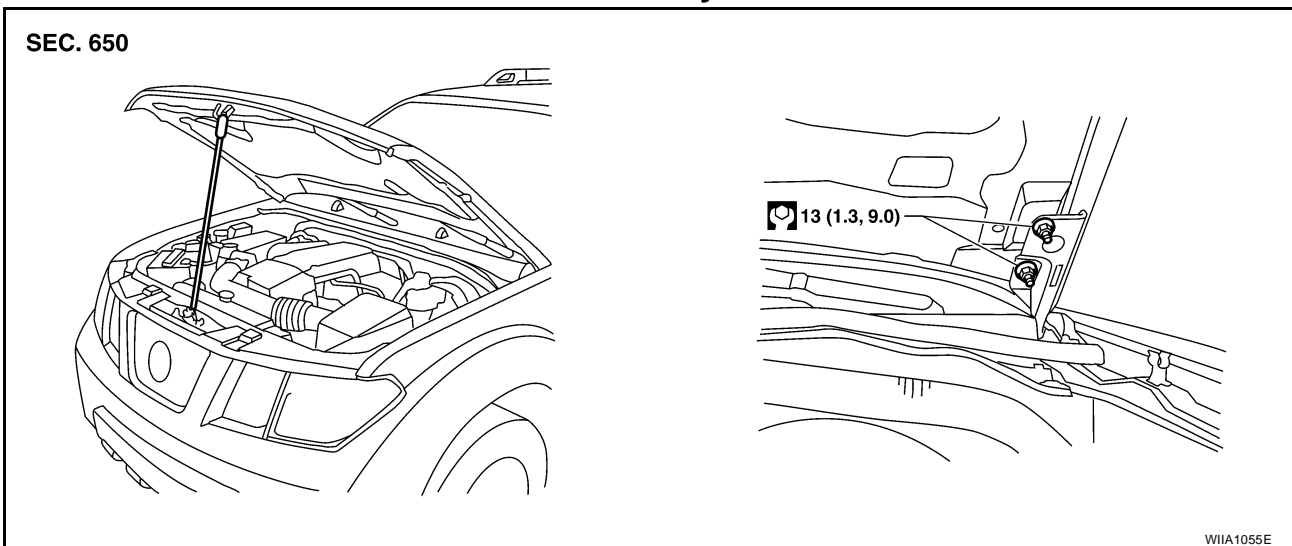

1. Support the hood assembly with a suitable tool to prevent it from falling.
2. Remove the hinge nuts from the hood to remove the hood assembly.

### CAUTION:

**Operate with two workers, because of its heavy weight.**

3. Installation is in the reverse order of removal.

# HOOD

## Removal and Installation of Hood Lock Control

EIS0063N

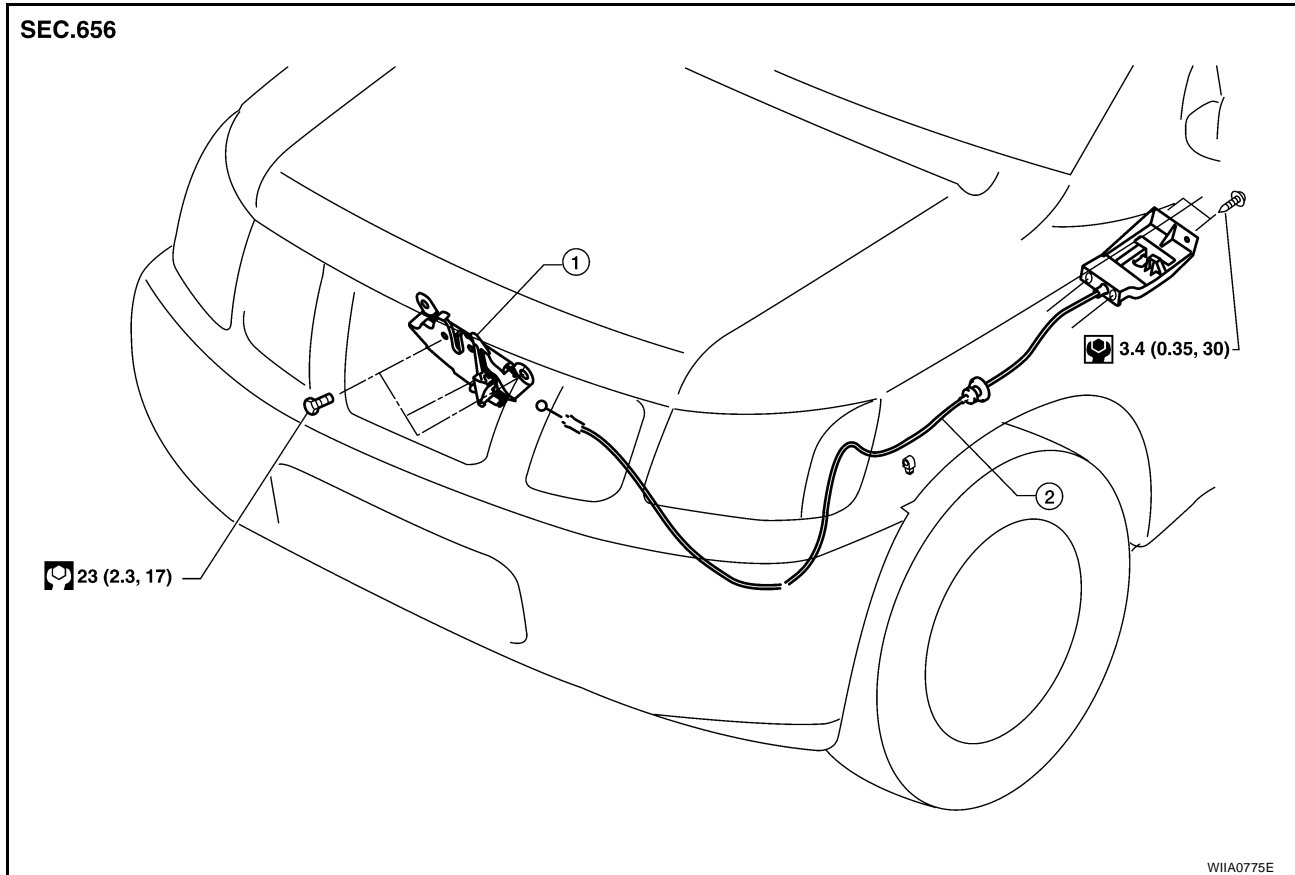

1. Hood lock assembly

2. Hood lock cable

### REMOVAL

1. Remove the front grill. Refer to [EI-16, "FRONT GRILLE"](#) .
2. Remove the front fender protector (LH). Refer to [EI-19, "FENDER PROTECTOR"](#) .
3. Disconnect the hood lock cable from the hood lock, and unclip it from the radiator core support upper and hood ledge.
4. Remove the bolts, and the hood release handle.
5. Separate the grommet from the lower dash panel. Pull the hood lock cable out through the passenger compartment.

#### **CAUTION:**

**While pulling, be careful not to damage the outside of the hood lock cable.**

### INSTALLATION

1. Pull the hood lock cable through the lower dash panel hole into the engine room.

# HOOD

Be careful not to bend the cable too much, keep the radius 100mm (3.94 in) or more.

2. Make sure the cable is not offset from the grommet, and push the grommet into the lower dash panel hole securely.
3. Install the hood release handle.
4. Apply sealant around the grommet at \* mark.

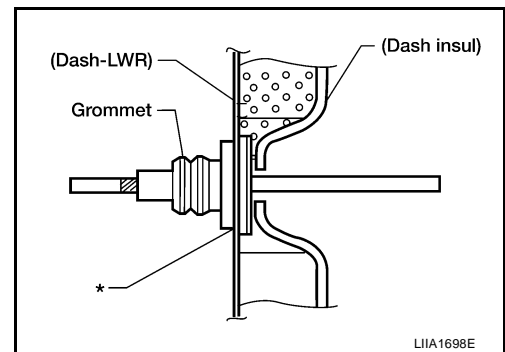

5. Install the cable securely to the lock.
6. Adjust the hood lock. Refer to [BL-13, "HOOD LOCK ADJUSTMENT"](#).



## Hood Lock Control Inspection

### CAUTION:

If the hood lock cable is bent or deformed, replace it.

1. Remove the front grille. Refer to [EI-16, "FRONT GRILLE"](#).
2. Make sure the secondary latch is properly engaged with the secondary striker with hood's own weight by dropping it from approx. 200 mm (7.87 in) height.
3. While operating the hood opener, carefully make sure the front end of the hood is raised by approx. 20 mm (0.79 in). Also make sure the hood opener returns to the original position.

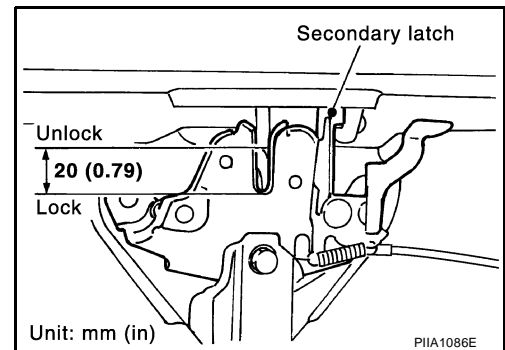

4. Check the hood lock lubrication condition. If necessary, apply "body grease" to the points as shown.
5. Install the front grille. Refer to [EI-16, "FRONT GRILLE"](#).

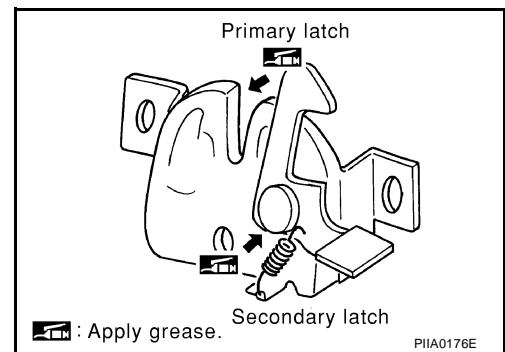

# POWER DOOR LOCK SYSTEM

## POWER DOOR LOCK SYSTEM

PFP:24814

### Component Parts and Harness Connector Location

EIS006BM

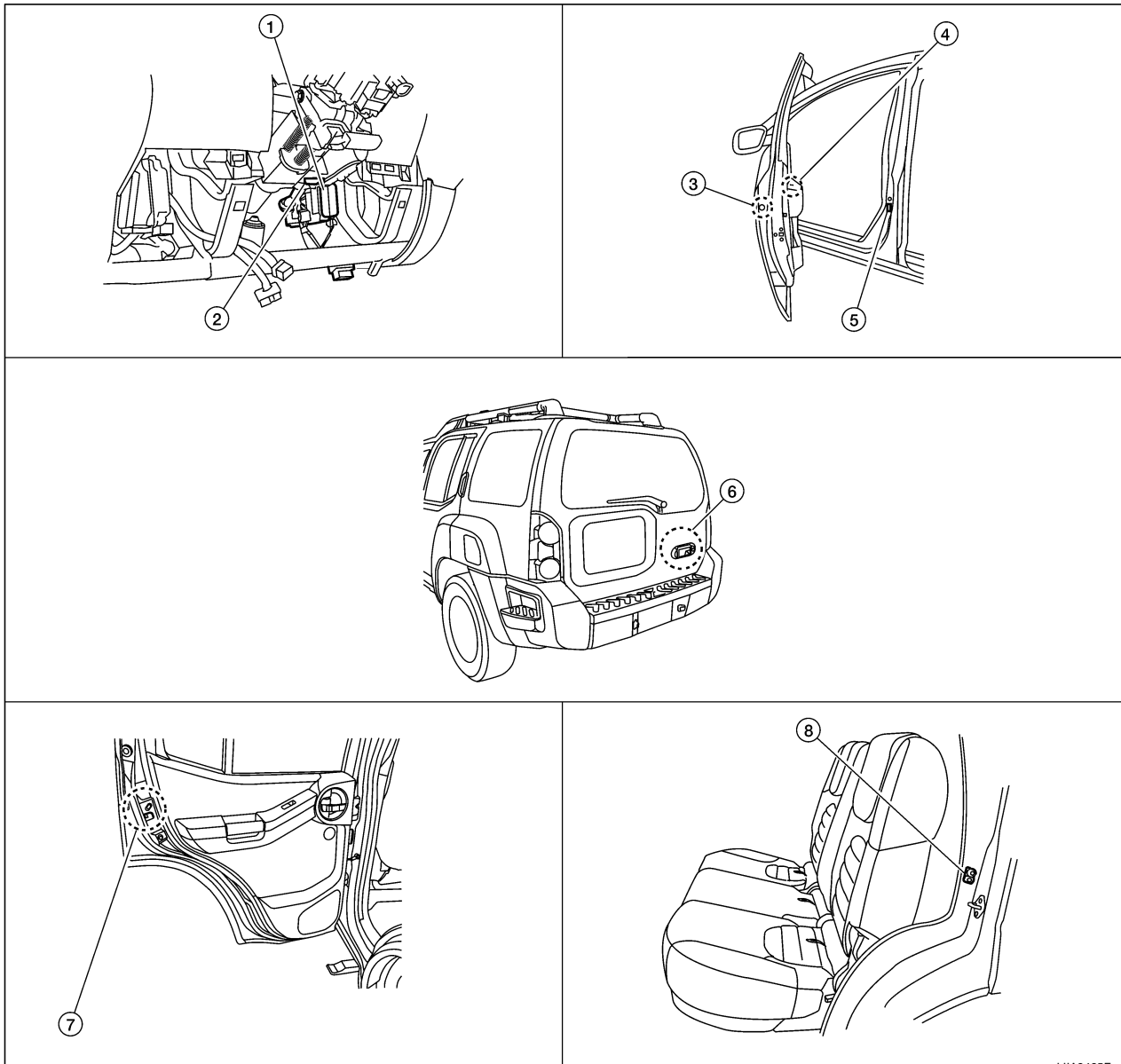

L1A2425E

- |   |  |  |
|---|--|--|
| 1. BCM M18, M19, M20<br>(view with instrument lower panel LH removed)                                   | 2. Key switch M27                        | 3. Front door lock assembly LH (key cylinder switch) D14<br>Front door lock actuator RH D114   |
| 4. Main power window and door lock/unlock switch D7<br>Power window and door lock/unlock switch RH D105 | 5. Front door switch<br>LH B8<br>RH B108 | 6. Back door switch D502<br>Back door key cylinder switch D505<br>Back door lock actuator D508 |
| 7. Rear door lock actuator<br>LH D205<br>RH D305  | 8. Rear door switch<br>LH B18<br>RH B116 |  |

### System Description

EIS006BN

Power is supplied at all times

- through 50A fusible link (letter **g**, located in the fuse and fusible link box)
- to BCM (body control module) terminal 70 and
- through 10A fuse (No. 25, located in the fuse and fusible link box)
- to key switch terminal 2



# POWER DOOR LOCK SYSTEM

- through 10A fuse [No. 18, located in the fuse block (J/B)]
- to BCM terminal 57.

Ground is supplied to terminal 67 of BCM through body grounds M57, M61 and M79.

## INPUT

With the key in the ignition key cylinder, power is supplied

- through key switch terminal 1
- to BCM terminal 37.

With front door LH open, ground is supplied

- to BCM terminal 47
- through front door switch LH terminal 2
- through front door switch LH case ground.

With front door RH open, ground is supplied

- to BCM terminal 12
- through front door switch RH terminal 2
- through front door switch RH case ground.

With rear door LH open, ground is supplied

- to BCM terminal 48
- through rear door switch LH terminal 2
- through rear door switch LH case ground.

With rear door RH open, ground is supplied

- to BCM terminal 13
- through rear door switch RH terminal 2
- through rear door switch RH case ground.

With back door open, ground is supplied

- to BCM terminal 43
- through back door switch terminal 3
- through back door switch terminal 1
- through body grounds D406 and D652.

With the key inserted in the key cylinder LH and turned to LOCK, ground is supplied

- to BCM terminal 8
- through front door lock assembly LH (key cylinder switch) terminal 5
- through front door lock assembly LH (key cylinder switch) terminal 4
- through body grounds M57, M61 and M79.

With the key inserted in the key cylinder LH and turned to UNLOCK, ground is supplied

- to BCM terminal 7
- through front door lock assembly LH (key cylinder switch) terminal 3
- through front door lock assembly (key cylinder switch) LH terminal 4
- through body grounds M57, M61 and M79.

With the key inserted in the back door key cylinder and turned to LOCK, ground is supplied

- to BCM terminal 8
- through back door key cylinder switch terminal 1
- through back door key cylinder switch terminal 2
- through body grounds D406 and D652.

With the key inserted in the back door key cylinder and turned to UNLOCK, ground is supplied

- to BCM terminal 7
- through back door key cylinder switch terminal 3
- through back door key cylinder switch terminal 2
- through body grounds D406 and D652.

A

B

C

D

E

F

G

H

BL

J

K

L

M

# POWER DOOR LOCK SYSTEM

---

With the main power window and door lock/unlock switch pressed to LOCK, ground is supplied

- to BCM terminal 45
- through main power window and door lock/unlock switch terminal 10
- through main power window and door lock/unlock switch terminal 14
- through body grounds M57, M61 and M79.

With the power window and door lock/unlock switch RH pressed to LOCK, ground is supplied

- to BCM terminal 45
- through power window and door lock/unlock switch RH terminal 1
- through power window and door lock/unlock switch RH terminal 3
- through body grounds M57, M61 and M79.

With the main power window and door lock/unlock switch pressed to UNLOCK, ground is supplied

- to BCM terminal 46
- through main power window and door lock/unlock switch terminal 11
- through main power window and door lock/unlock switch terminal 14
- through body grounds M57, M61 and M79.

With the power window and door lock/unlock switch RH pressed to UNLOCK, ground is supplied

- to BCM terminal 46
- through power window and door lock/unlock switch RH terminal 2
- through power window and door lock/unlock switch RH terminal 3
- through body grounds M57, M61 and M79.

## OUTPUT

### Unlock

Ground is supplied

- to front door lock assembly LH (actuator) terminal 1, front door lock actuator RH terminal 2, rear door lock actuator LH and RH terminal 2 and back door lock actuator terminal 2
- through BCM terminal 65.

### FRONT DOOR LH

Power is supplied

- to front door lock assembly LH (actuator) terminal 2 and
- through BCM terminal 59.

### FRONT DOOR RH

Power is supplied

- to front door lock actuator RH terminal 1
- through BCM terminal 66.

### REAR DOOR LH AND RH

Power is supplied

- to rear door lock actuator LH and RH terminal 1
- through BCM terminal 66.

### BACK DOOR

Power is supplied

- to back door lock actuator terminal 4
- through BCM terminal 66.

With power and ground applied as described, the doors are unlocked.

### Lock

Ground is supplied

- to front door lock assembly LH (actuator) terminal 2
- through BCM terminal 59 and
- to front door lock actuator RH terminal 1, rear door lock actuator LH and RH terminal 1 and back door lock actuator terminal 4

# POWER DOOR LOCK SYSTEM

- through BCM terminal 66.

Power is supplied

- to front door lock assembly LH (actuator) terminal 1
- front door lock actuator RH terminal 2
- rear door lock actuator LH and RH terminal 2
- back door lock actuator terminal 2
- through BCM terminal 65.

With power and ground applied as described, the doors are locked.

## OPERATION

- The main power window and door lock/unlock switch on front door LH trim and door lock/unlock switch RH on front door RH trim can lock and unlock all doors.
- With the key inserted in the front door key cylinder LH or back door key cylinder, turning it to LOCK locks all doors; turning it to UNLOCK once unlocks the front door LH; turning it to UNLOCK again within 5 seconds of the first unlock operation unlocks all other doors [signal from door key cylinder switch (part of front door lock assembly LH)].

## Key Reminder

When performing a door locking operation using either the main power window and door lock/unlock switch or the power window and door lock/unlock switch RH, all the doors will lock and then will immediately unlock if

- the key switch is in INSERTED position (key is in ignition key cylinder) and
- the ignition switch is in the OFF position and
- any door is open.

A

B

C

D

E

F

G

H

BL

J

K

L

M

# POWER DOOR LOCK SYSTEM

## Schematic

EIS006B0

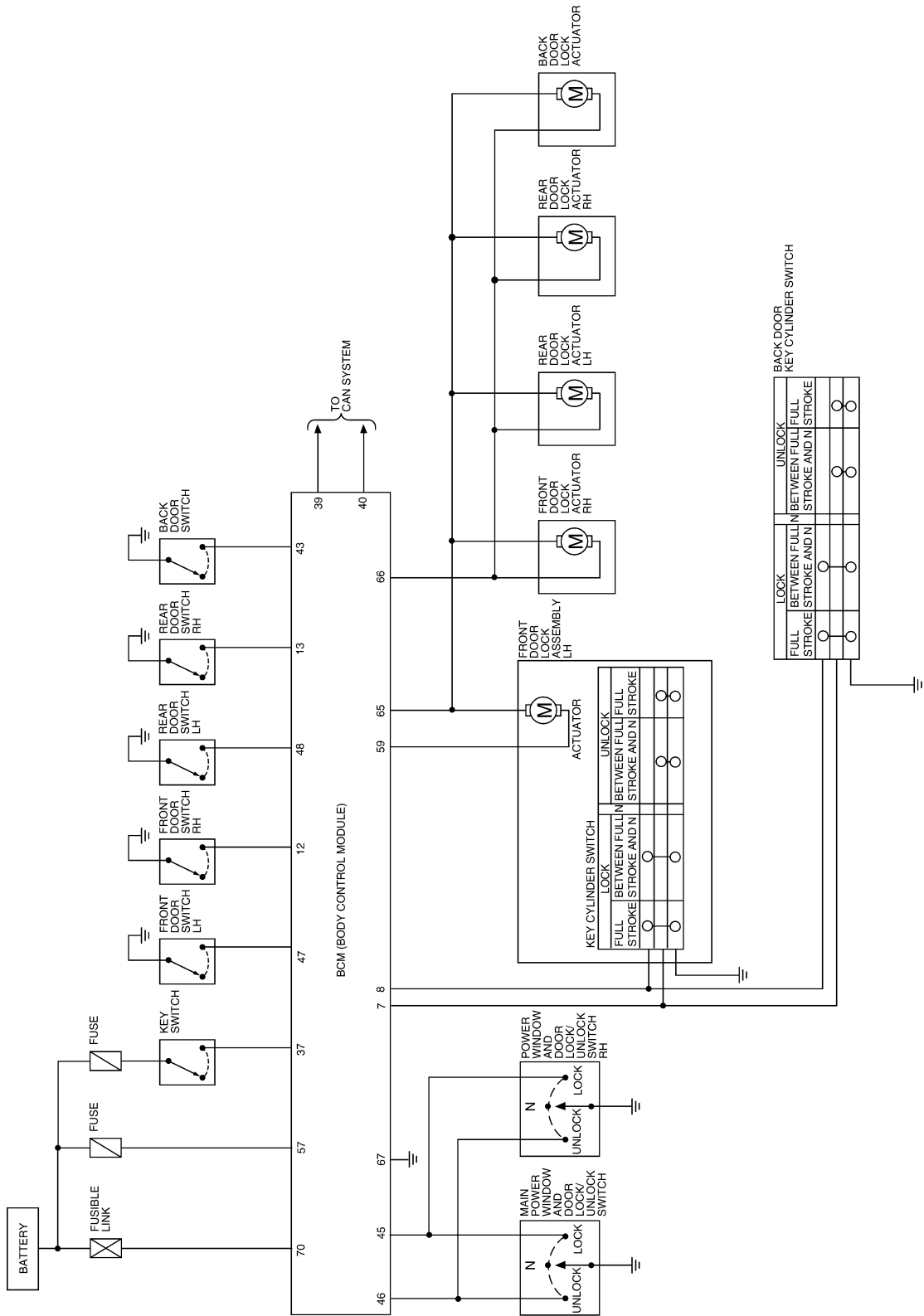

WIWA1686E

# POWER DOOR LOCK SYSTEM

## Wiring Diagram — D/LOCK —

EIS006BP

### BL-D/LOCK-01

▬ : DATA LINE

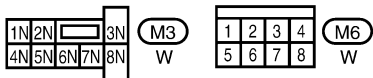
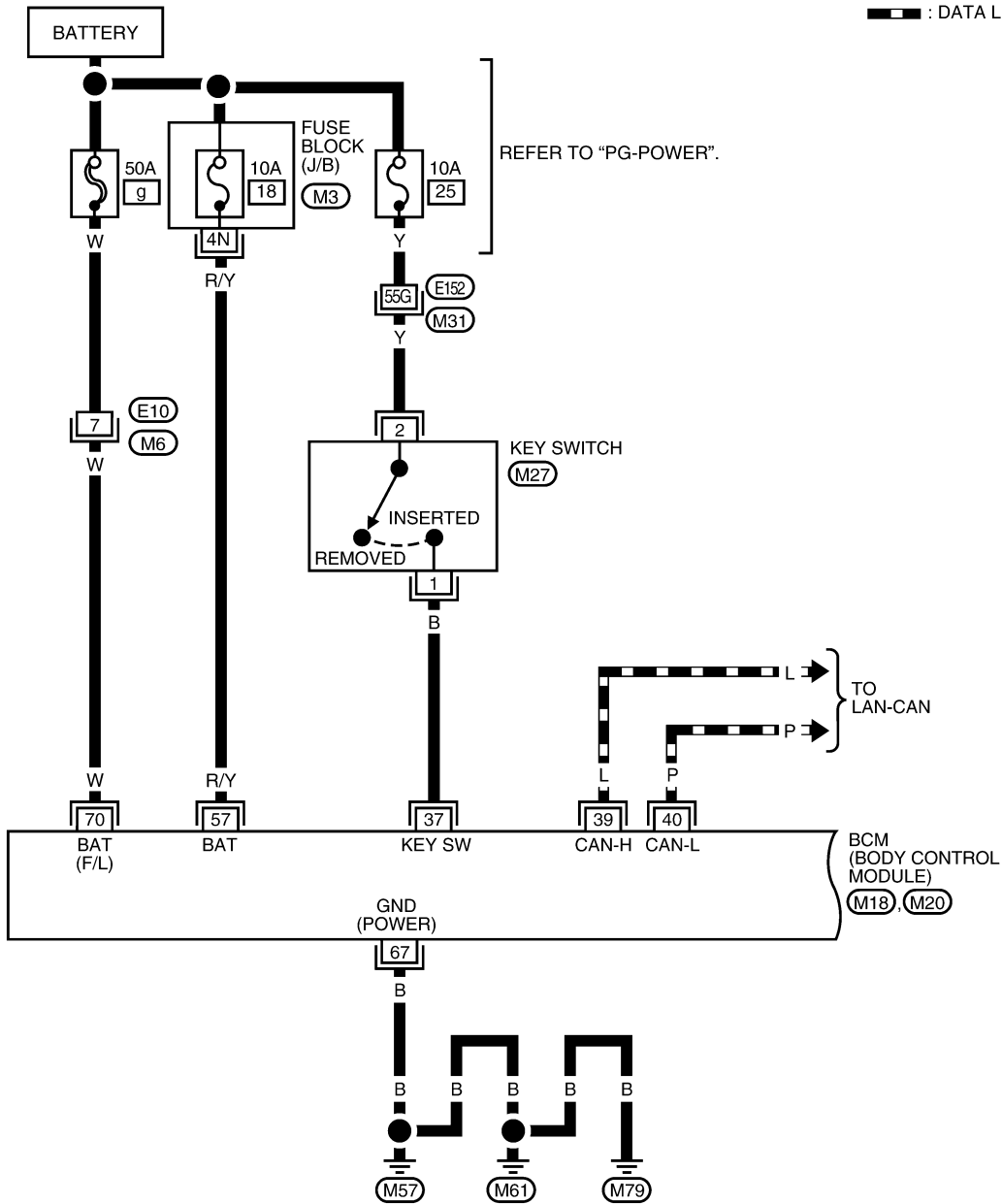

REFER TO THE FOLLOWING.  
 (M31) - SUPER MULTIPLE JUNCTION (SMJ)

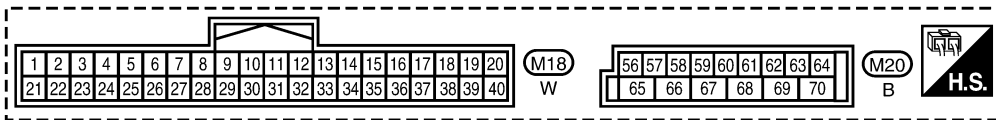

WIWA1687E

# POWER DOOR LOCK SYSTEM

BL-D/LOCK-02

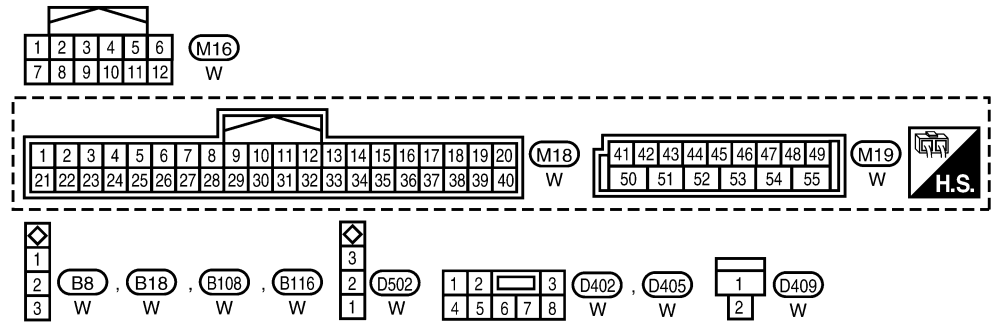
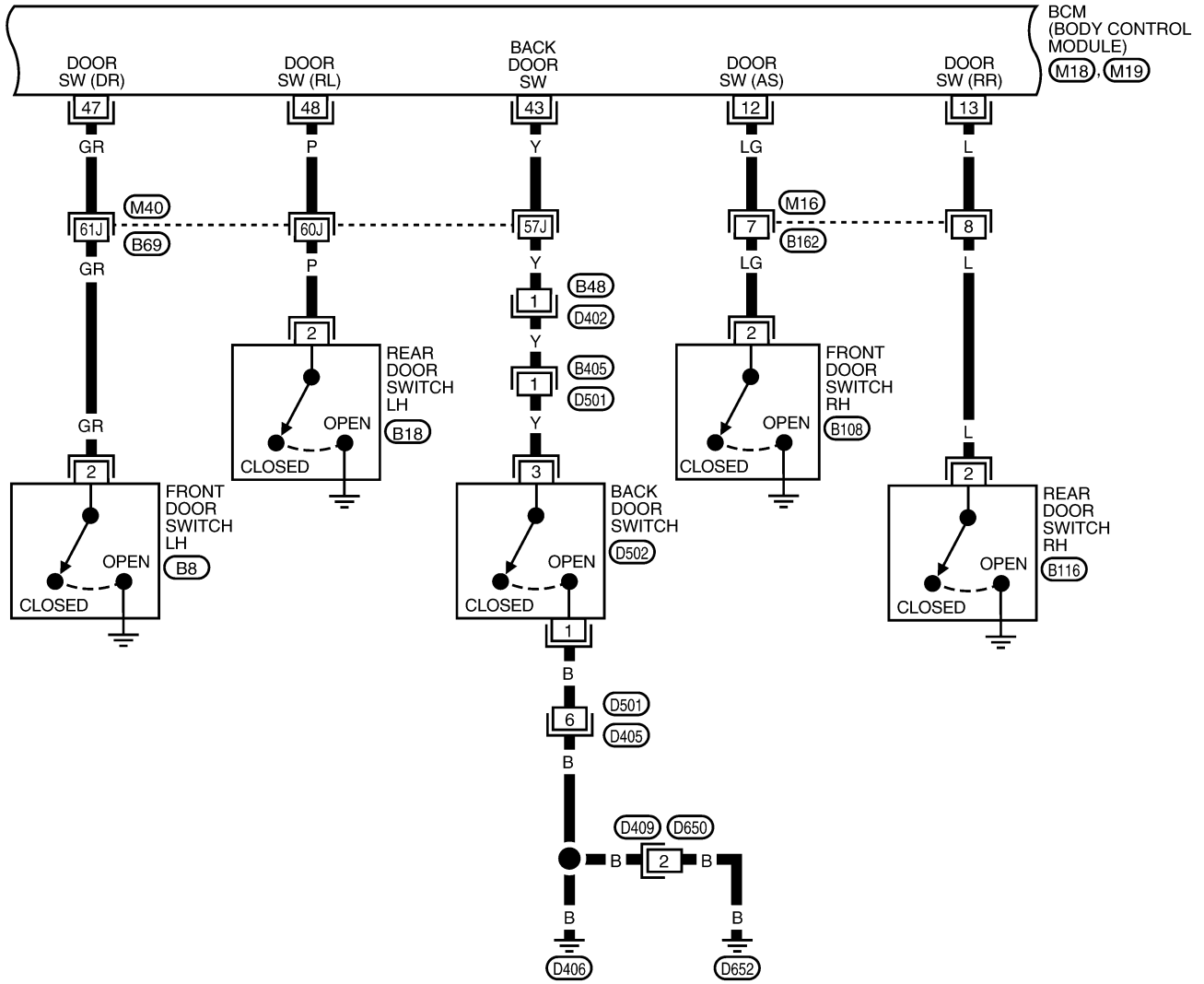

REFER TO THE FOLLOWING.  
 (M40) - SUPER MULTIPLE JUNCTION (SMJ)

WIWA0815E

# POWER DOOR LOCK SYSTEM

BL-D/LOCK-03

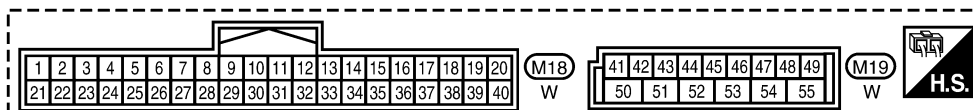
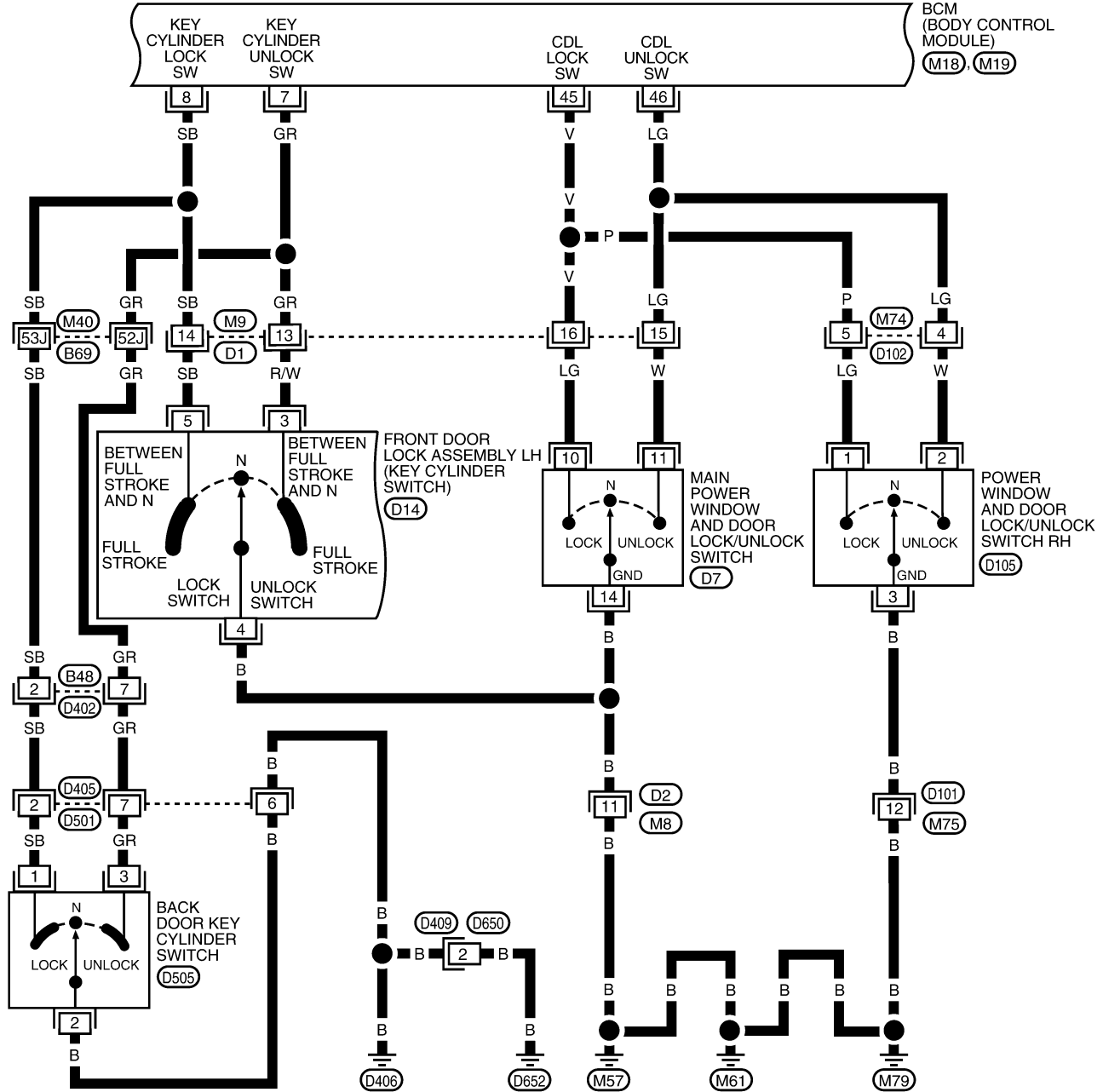

REFER TO THE FOLLOWING.  
 (M40) - SUPER MULTIPLE JUNCTION (SMJ)

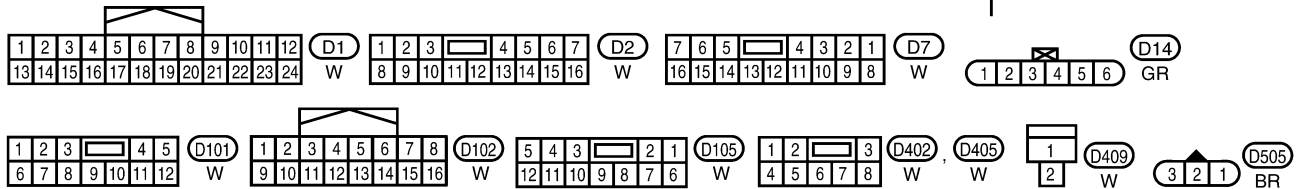

WIWA0816E

# POWER DOOR LOCK SYSTEM

BL-D/LOCK-04

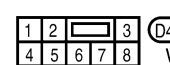
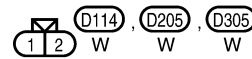
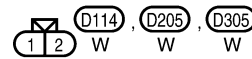
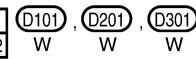
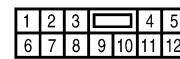
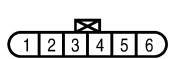
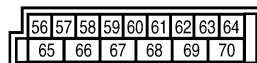
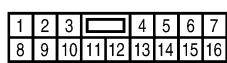
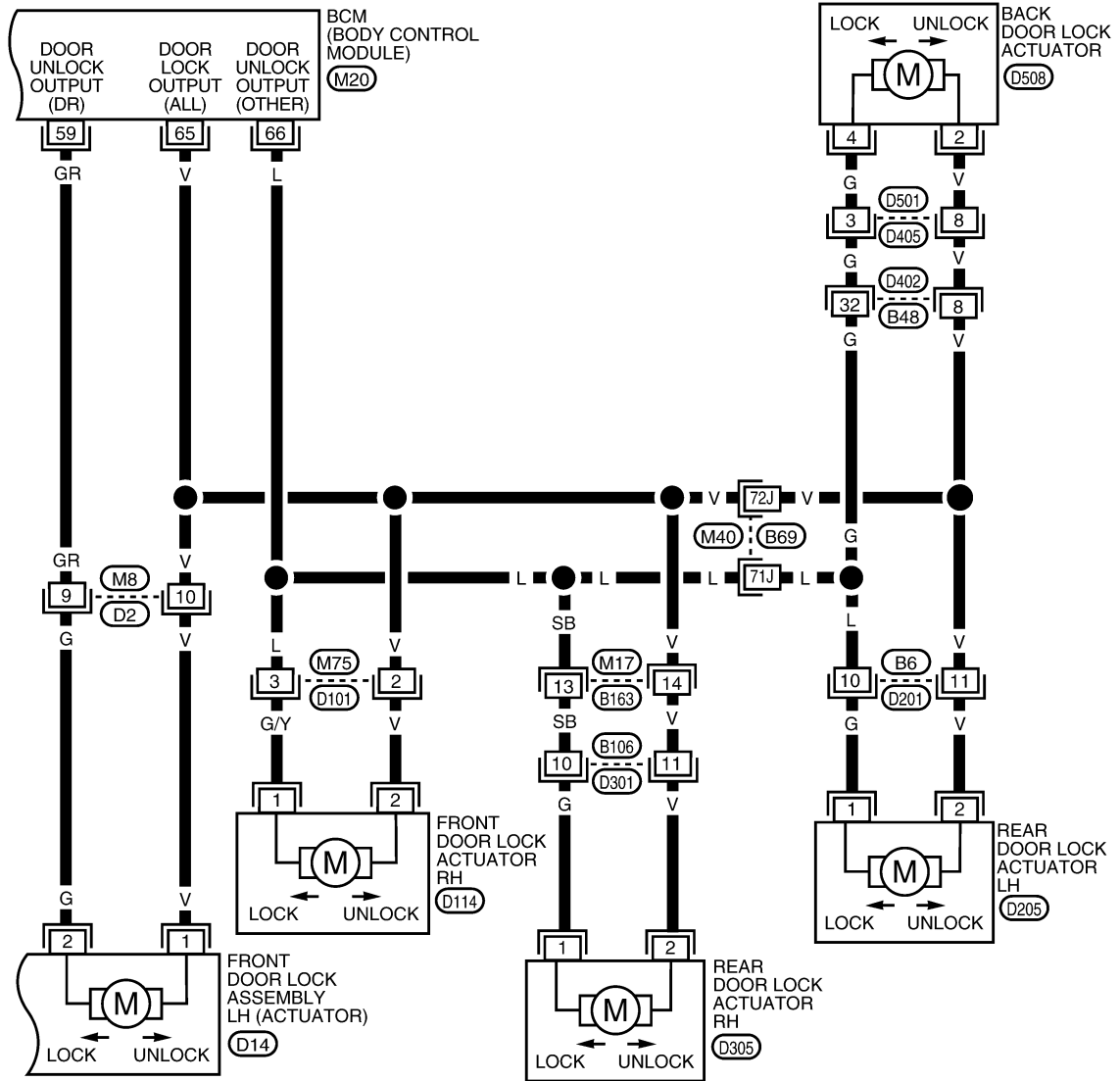

REFER TO THE FOLLOWING.  
 - SUPER MULTIPLE JUNCTION (SMJ)

WIWA1688E



# POWER DOOR LOCK SYSTEM

## Terminals and Reference Value for BCM

EIS006BQ

Refer to [BCS-12, "Terminals and Reference Values for BCM"](#) .

## Work Flow

EIS006BR

1. Check the symptom and customer's requests. A
2. Understand the outline of system. Refer to [BL-16, "System Description"](#) . B
3. According to the trouble diagnosis chart, repair or replace the cause of the malfunction. Refer to [BL-28, "Trouble Diagnoses Symptom Chart"](#) . C
4. Does power door lock system operate normally? OK: GO TO 5, NG: GO TO 3. D
5. Inspection End. E

E

F

G

H

BL

J

K

L

M

# POWER DOOR LOCK SYSTEM

EIS006BS

## CONSULT-II Function (BCM)

CONSULT-II can display each diagnostic item using the diagnostic test modes shown following.

BCM diagnostic test item	Diagnostic mode	Description
Inspection by part	WORK SUPPORT	Supports inspections and adjustments. Commands are transmitted to the BCM for setting the status suitable for required operation, input/output signals are received from the BCM and received data is displayed.
	DATA MONITOR	Displays BCM input/output data in real time.
	ACTIVE TEST	Operation of electrical loads can be checked by sending drive signal to them.
	SELF-DIAG RESULTS	Displays BCM self-diagnosis results.
	CAN DIAG SUPPORT MNTR	The result of transmit/receive diagnosis of CAN communication can be read.
	ECU PART NUMBER	BCM part number can be read.
	CONFIGURATION	Performs BCM configuration read/write functions.

## CONSULT-II INSPECTION PROCEDURE

### "DOOR LOCK"

#### CAUTION:

If CONSULT-II is used with no connection of CONSULT-II CONVERTER, malfunctions might be detected in self-diagnosis depending on control unit which carries out CAN communication.

1. Turn ignition switch OFF.
2. Connect CONSULT-II and CONSULT-II CONVERTER to the data link connector.

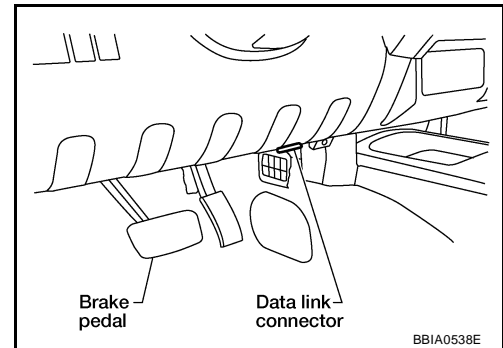

3. Turn ignition switch ON.
4. Touch "START (NISSAN BASED VHCL)".

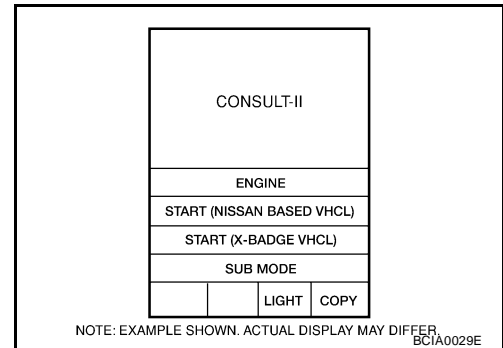

5. Touch "BCM".  
If "BCM" is not indicated, refer to [GI-41, "CONSULT-II Data Link Connector \(DLC\) Circuit"](#).

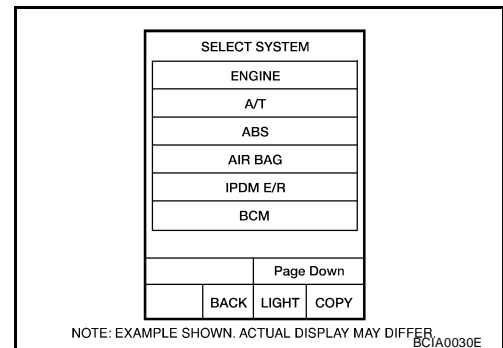

# POWER DOOR LOCK SYSTEM

6. Touch "DOOR LOCK".

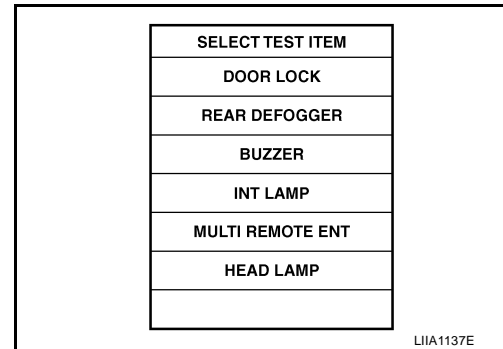

7. Select diagnosis mode. "WORK SUPPORT", "DATA MONITOR" and "ACTIVE TEST" are available.

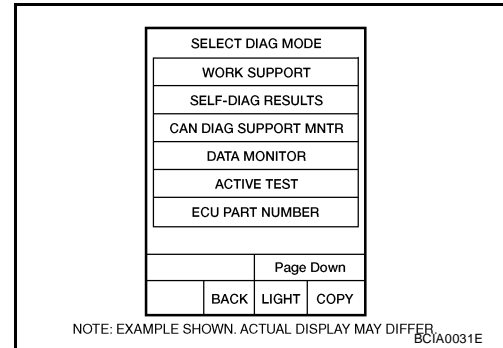

## WORK SUPPORT

Work item	Content
DOOR LOCK-UNLOCK SET	Select unlock mode can be changed in this mode. Selects ON-OFF of select unlock mode.
ANTI-LOCK OUT SET	Key reminder door mode can be changed in this mode. Selects ON-OFF of key reminder door mode.

## DATA MONITOR

Monitor item "OPERATION"	Content
KEY ON SW	"ON/OFF" Indicates [ON/OFF] condition of key switch.
CDL LOCK SW	"ON/OFF" Indicates [ON/OFF] condition of lock signal from lock/unlock switch LH and RH.
CDL UNLOCK SW	"ON/OFF" Indicates [ON/OFF] condition of unlock signal from lock/unlock switch LH and RH.
KEY CYL LK-SW	"ON/OFF" Indicates [ON/OFF] condition of lock signal from key cylinder.
KEY CYL UN-SW	"ON/OFF" Indicates [ON/OFF] condition of unlock signal from key cylinder.
IGN ON SW	"ON/OFF" Indicates [ON/OFF] condition of ignition switch.
DOOR SW-DR	"ON/OFF" Indicates [ON/OFF] condition of front door switch LH.
DOOR SW-AS	"ON/OFF" Indicates [ON/OFF] condition of front door switch RH.
DOOR SW-RR	"ON/OFF" Indicates [ON/OFF] condition of rear door switch RH.
DOOR SW-RL	"ON/OFF" Indicates [ON/OFF] condition of rear door switch LH.
BACK DOOR SW	"ON/OFF" Indicates [ON/OFF] condition of back door switch.

## ACTIVE TEST

Test item	Content
DOOR LOCK	ALL LOCK/UNLOCK This test is able to check all door lock actuators lock operation. These actuators lock when "ON" on CONSULT-II screen is touched.
	DR UNLOCK This test is able to check front door lock assembly LH unlock operation. These actuators lock when "ON" on CONSULT-II screen is touched.
	OTHER UNLOCK This test is able to check door lock actuators (except front door lock assembly LH) unlock operation. These actuators unlock when "ON" on CONSULT-II screen is touched.

# POWER DOOR LOCK SYSTEM

## Trouble Diagnoses Symptom Chart

EIS006BT

Symptom	Repair order	Refer to page
Key reminder door system does not operate properly.	1. Door switch check	<a href="#">BL-29</a>
	2. Key switch (insert) check	<a href="#">BL-32</a>
	3. Replace BCM.	<a href="#">BCS-26</a>
Power door lock does not operate with door lock and unlock switch on main power window and door lock/unlock switch or power window and door lock/unlock switch RH.	1. Door lock/unlock switch check	<a href="#">BL-33</a>
Front door lock assembly LH does not operate.	1. Front door lock assembly LH (actuator) check	<a href="#">BL-36</a>
Specific door lock actuator does not operate.	1. Front door lock assembly RH (actuator) check	<a href="#">BL-37</a>
	2. Back door lock actuator and rear door lock actuator LH/RH check	<a href="#">BL-38</a>
Power door lock does not operate with front door key cylinder LH or back door key cylinder operation.	1. Front door lock assembly LH (key cylinder switch) check	<a href="#">BL-39</a>
	2. Back door key cylinder switch check.	<a href="#">BL-41</a>
	3. Replace BCM.	<a href="#">BCS-26</a>
Power door lock does not operate.	1. BCM power supply and ground circuit check	<a href="#">BL-28</a>
	2. Door lock/unlock switch check	<a href="#">BL-33</a>

## BCM Power Supply and Ground Circuit Check

EIS006BU

Refer to [BCS-16, "BCM Power Supply and Ground Circuit Check"](#) .

# POWER DOOR LOCK SYSTEM

EIS006BV

## Door Switch Check

### 1. CHECK DOOR SWITCHES INPUT SIGNAL

 With CONSULT-II

Check door switches ("DOOR SW-DR", "DOOR SW-AS", "DOOR SW-RL", "DOOR SW-RR", "BACK DOOR SW") in DATA MONITOR mode with CONSULT-II. Refer to [BL-27, "DATA MONITOR"](#).

- When doors are open:

**DOOR SW-DR : ON**  
**DOOR SW-AS : ON**  
**DOOR SW-RL : ON**  
**DOOR SW-RR : ON**  
**BACK DOOR SW : ON**

- When doors are closed:

**DOOR SW-DR : OFF**  
**DOOR SW-AS : OFF**  
**DOOR SW-RL : OFF**  
**DOOR SW-RR : OFF**  
**BACK DOOR SW : OFF**

DATA MONITOR	
MONITOR	
DOOR SW - DR	OFF
DOOR SW - AS	OFF
DOOR SW - RR	OFF
DOOR SW - RL	OFF
BACK DOOR SW	OFF

LIA0665E

 Without CONSULT-II

Check voltage between BCM connector M18 or M19 terminals 12, 13, 43, 47, 48 and ground.

Connector	Item	Terminals		Condition	Voltage (V) (Approx.)
		(+)	(-)		
M19	Back door switch	43	Ground	Open ↓ Closed	0 ↓ Battery voltage
	Front door switch LH	47			
	Rear door switch LH	48			
M18	Front door switch RH	12			
	Rear door switch RH	13			

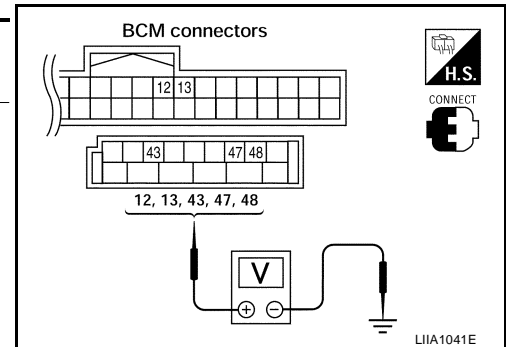

#### OK or NG

- OK >> Door switch circuit is OK.
- NG >> GO TO 2.

# POWER DOOR LOCK SYSTEM

## 2. CHECK BCM OUTPUT VOLTAGE

1. Turn ignition switch OFF.
2. Disconnect door switches.
3. Check voltage between BCM connector M18, M19 terminals 12, 13, 43, 47, 48 and ground.

**12 - Ground : Battery voltage**  
**13 - Ground : Battery voltage**  
**43 - Ground : Battery voltage**  
**47 - Ground : Battery voltage**  
**48 - Ground : Battery voltage**

OK or NG

OK >> GO TO 3.

NG >> Replace BCM. Refer to [BCS-26, "Removal and Installation of BCM"](#) .

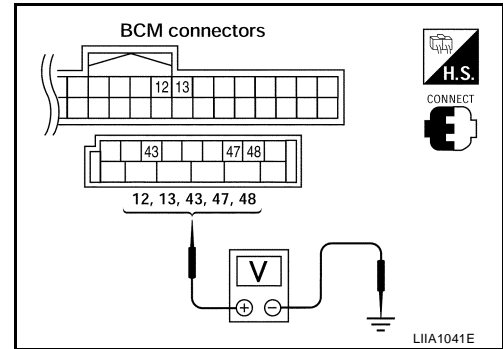

## 3. CHECK DOOR SWITCH CIRCUIT

1. Turn ignition switch OFF.
2. Disconnect door switch and BCM.
3. Check continuity between door switch connector B8 (Front LH), B108 (Front RH), B18 (Rear LH), B116 (Rear RH) terminal 2 or D502 (Back) terminal 3 and BCM connector M18, M19 terminals 12, 13, 43, 47 and 48.

**2 - 47 : Continuity should exist.**  
**2 - 12 : Continuity should exist.**  
**2 - 48 : Continuity should exist.**  
**2 - 13 : Continuity should exist.**  
**3 - 43 : Continuity should exist.**

4. Check continuity between door switch connector B8 (Front LH), B108 (Front RH), B18 (Rear LH), B116 (Rear RH) terminal 2 or D502 (Back) terminal 3 and ground.

**2 - Ground : Continuity should not exist.**  
**3 - Ground : Continuity should not exist.**

OK or NG

OK >> GO TO 4.

NG >> Repair or replace harness.

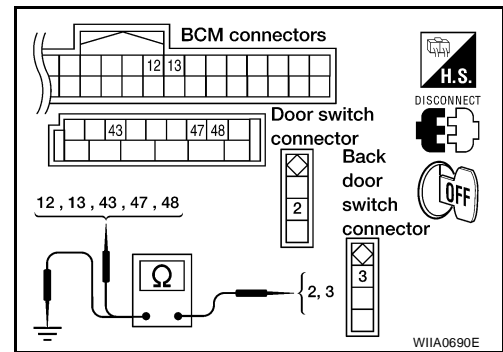

# POWER DOOR LOCK SYSTEM

## 4. CHECK DOOR SWITCHES

### FRONT AND REAR DOORS

Check continuity between front or rear door switch terminal 2 and exposed metal of switch while pressing and releasing switch.

**When front or rear door switch is released** : Continuity should exist.

**When front or rear door switch is pushed** : Continuity should not exist.

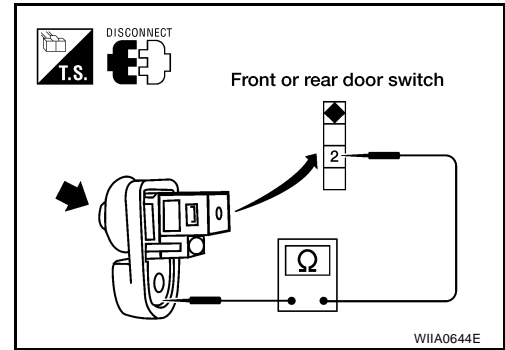

### BACK DOOR

Check continuity between back door switch terminals 3 and 1 while pressing and releasing switch.

**When back door switch is released** : Continuity should exist.

**When back door switch is pushed** : Continuity should not exist.

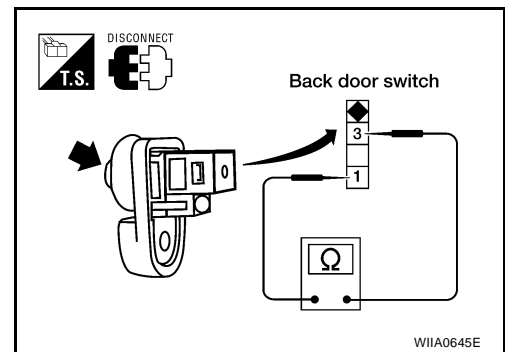

### OK or NG

- OK >> Check switch case ground condition (front and rear door) or ground circuit (back door).
- NG >> Replace door switch.

A  
B  
C  
D  
E  
F  
G  
H  
J  
K  
L  
M

BL

# POWER DOOR LOCK SYSTEM

EIS006BW

## Key Switch (Insert) Check

### 1. CHECK KEY SWITCH INPUT SIGNAL

 With CONSULT-II

Check key switch "KEY ON SW" in DATA MONITOR mode with CONSULT-II. Refer to [BL-27, "DATA MONITOR"](#).

- When key is inserted to ignition key cylinder:  
**KEY ON SW : ON**
- When key is removed from ignition key cylinder:  
**KEY ON SW : OFF**

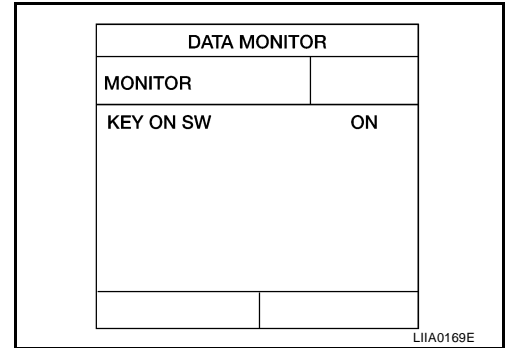

 Without CONSULT-II

Check voltage between BCM connector M18 terminal 37 and ground.

Connector	Terminal		Condition	Voltage (V)
	(+)	(-)		
M18	37	Ground	Key is inserted.	Battery voltage
			Key is removed.	0

OK or NG

- OK >> Key switch (insert) circuit is OK.
- NG >> GO TO 2.

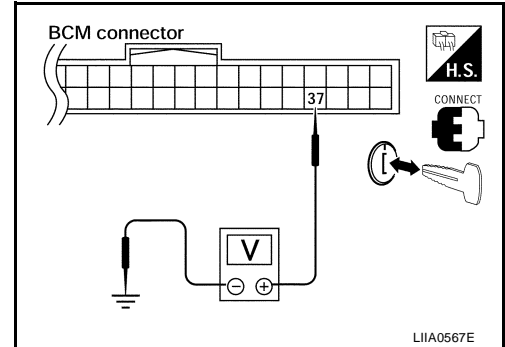

### 2. CHECK KEY SWITCH (INSERT)

- Turn ignition switch OFF.
- Disconnect key switch connector.
- Check continuity between key switch terminals.

Terminals	Condition	Continuity
1 - 2	Key is inserted.	Yes
	Key is removed.	No

OK or NG

- OK >> Repair or replace harness or fuse.
- NG >> Replace key switch.

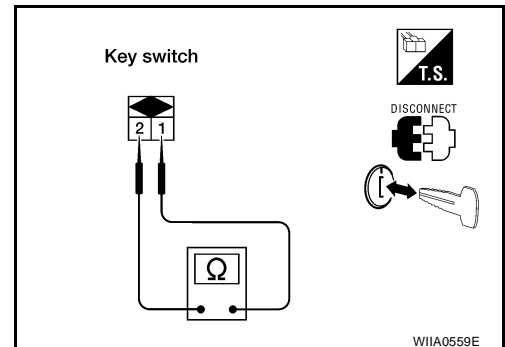



# POWER DOOR LOCK SYSTEM

## Door Lock/Unlock Switch Check

EIS006BX

### 1. CHECK DOOR LOCK/UNLOCK SWITCH INPUT SIGNAL

 With CONSULT-II

Check door lock/unlock switch ("CDL LOCK SW", "CDL UNLOCK SW") in DATA MONITOR mode in CONSULT-II. Refer to [BL-27, "DATA MONITOR"](#).

- When door lock/unlock switch is turned to LOCK:  
**CDL LOCK SW : ON**
- When door lock/unlock switch is turned to UNLOCK:  
**CDL UNLOCK SW : ON**

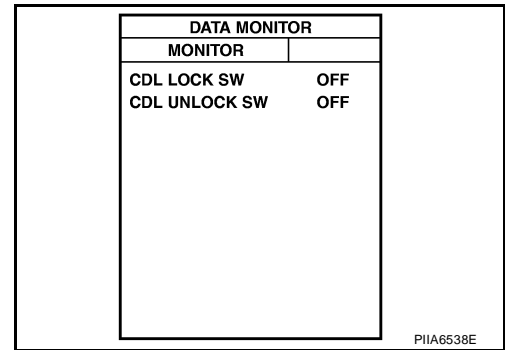

 Without CONSULT-II

Check voltage between BCM connector M19 terminals 45, 46 and ground.

Connector	Terminals		Condition	Voltage (V) (Approx.)
	(+)	(-)		
M19	46	Ground	Door lock/unlock switch is neutral.	Battery voltage
			Door lock/unlock switch is turned to UNLOCK.	0
	45	Ground	Door lock/unlock switch is neutral.	Battery voltage
			Door lock/unlock switch is turned to LOCK.	0

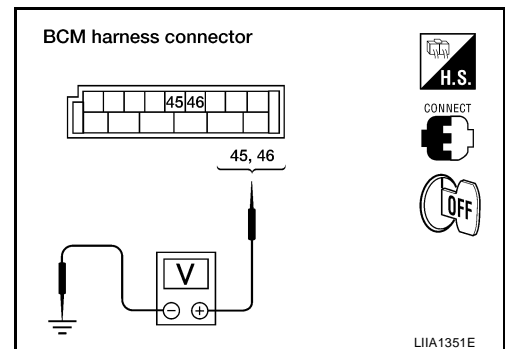

#### OK or NG

- OK >> Door lock/unlock switch circuit is OK.
- NG >> GO TO 2.

# POWER DOOR LOCK SYSTEM

## 2. CHECK DOOR LOCK/UNLOCK SWITCH

1. Turn ignition switch OFF.
2. Disconnect door lock/unlock switch.
3. Check continuity between main power window and door lock/unlock switch terminals 10, 11 and 14.

Terminal	Condition	Continuity
10	Lock	Yes
	Unlock/Neutral	No
11	Unlock	Yes
	Lock/Neutral	No

4. Check continuity between power window and door lock/unlock switch RH terminals 1, 2 and 3.

Terminal	Condition	Continuity
1	Lock	Yes
	Unlock/Neutral	No
2	Unlock	Yes
	Lock/Neutral	No

OK or NG

- OK >> GO TO 3.  
 NG >> Replace door lock/unlock switch.

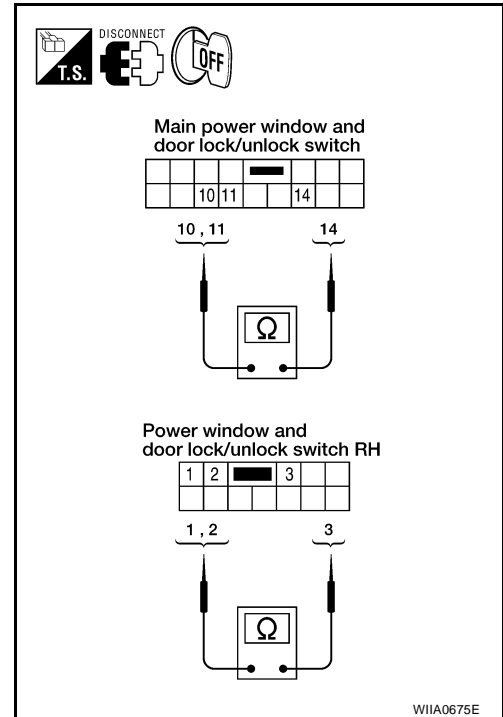

## 3. CHECK DOOR LOCK/UNLOCK SWITCH GROUND HARNESS

1. Disconnect main power window and door lock/unlock switch or power window and door lock/unlock switch RH.
2. Check continuity between main power window and door lock/unlock switch connector D7 terminal 14 and ground.

**14 - Ground : Continuity should exist.**

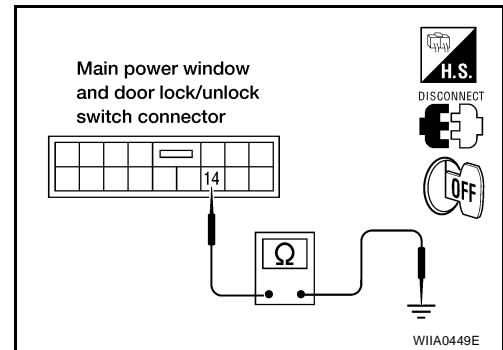

3. Check continuity between power window and door lock/unlock switch RH connector D105 terminal 3 and ground

**3 - Ground : Continuity should exist.**

OK or NG

- OK >> GO TO 4.  
 NG >> Repair or replace harness.

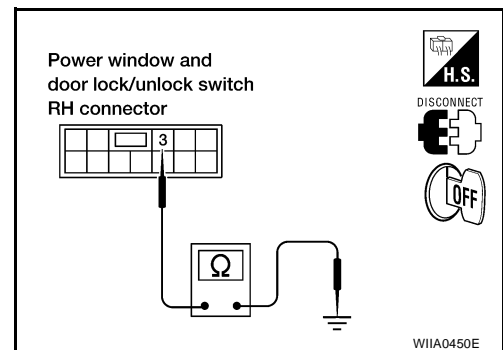

# POWER DOOR LOCK SYSTEM

## 4. CHECK DOOR LOCK SWITCH CIRCUIT

1. Disconnect BCM.
2. Check continuity between BCM connector M19 terminal 45 and main power window and door lock/unlock switch connector D7 terminal 10 or power window and door lock/unlock switch RH connector D105 terminal 1.

**1 - 45** : Continuity should exist.

**10 - 45** : Continuity should exist.

3. Check continuity between BCM connector M19 terminal 45 and ground.

**45 - Ground** : Continuity should not exist.

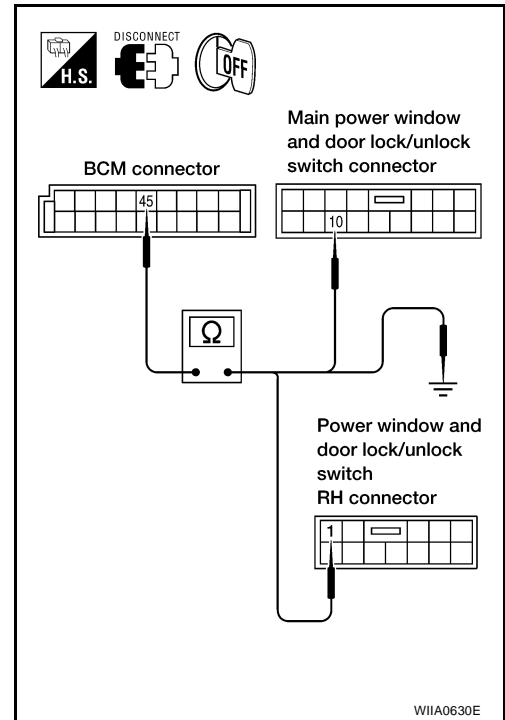

4. Check continuity between BCM connector M19 terminal 46 and main power window and door lock/unlock switch LH connector D7 terminal 11 or power window and door lock/unlock switch RH connector D105 terminal 2.

**2 - 46** : Continuity should exist.

**11 - 46** : Continuity should exist.

5. Check continuity between BCM connector M19 terminal 46 and ground.

**46 - Ground** : Continuity should not exist.

OK or NG

OK >> GO TO 5.

NG >> Repair or replace harness.

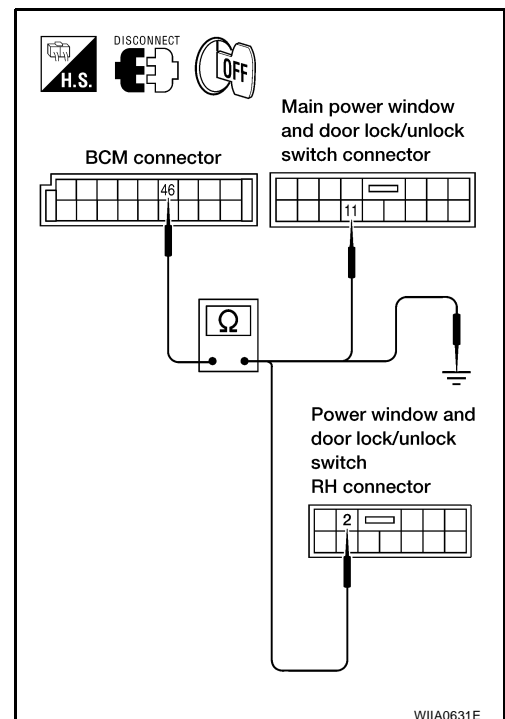

# POWER DOOR LOCK SYSTEM

## 5. CHECK BCM OUTPUT VOLTAGE

1. Connect BCM.
2. Check voltage between BCM connector M19 terminals 45, 46 and ground.

**45 - Ground : Battery voltage**  
**46 - Ground : Battery voltage**

OK or NG

- OK >> Check condition of the harness and connector.  
 NG >> Replace BCM. Refer to [BCS-26, "Removal and Installation of BCM"](#) .

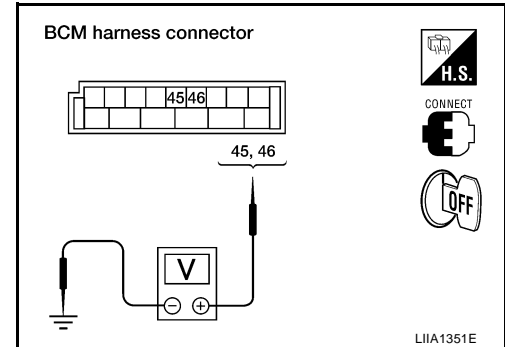

EIS006BY

## Front Door Lock Assembly LH (Actuator) Check

### 1. CHECK DOOR LOCK ACTUATOR SIGNAL

1. Turn ignition switch OFF.
2. Check voltage between BCM connector M20 terminals 59, 65 and ground.

Connector	Terminals		Condition	Voltage (V) (Approx.)
	(+)	(-)		
M20	59	Ground	Driver door lock/unlock switch is turned to UNLOCK	0 → Battery voltage
	65		Driver door lock/unlock switch is turned to LOCK	0 → Battery voltage

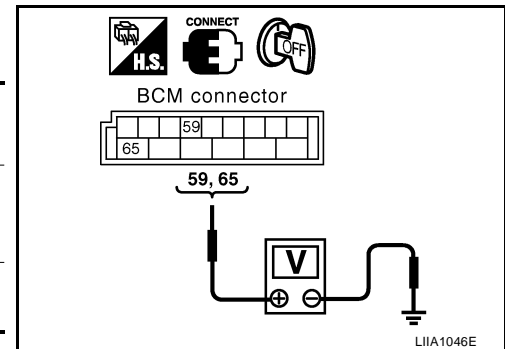

OK or NG

- OK >> GO TO 2.  
 NG >> Replace BCM. Refer to [BCS-26, "Removal and Installation of BCM"](#) .

### 2. CHECK DOOR LOCK ACTUATOR HARNESS

1. Disconnect BCM and front door lock assembly LH (actuator).
2. Check continuity between BCM connector M20 terminals 59, 65 and front door lock assembly LH (actuator) connector D14 terminals 1, 2.

Connector	Terminals	Connector	Terminals	Continuity
M20	59	D14	2	Yes
	65		1	Yes

3. Check continuity between BCM connector M20 terminals 59, 65 and ground.

Connector	Terminals	Continuity
M20	59	No
	65	No

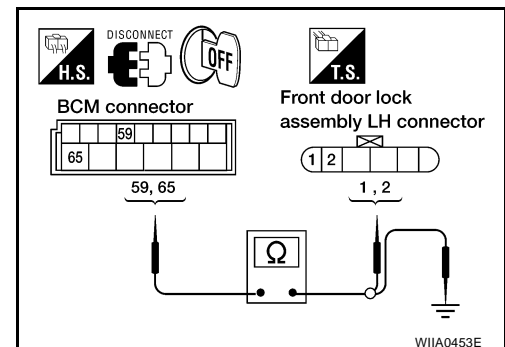

OK or NG

- OK >> Replace front door lock assembly LH (actuator). Refer to [BL-97, "Removal and Installation"](#) .  
 NG >> Repair or replace harness.

# POWER DOOR LOCK SYSTEM

EIS006BZ

## Front Door Lock Actuator RH Check

### 1. CHECK FRONT DOOR LOCK ACTUATOR RH SIGNAL

1. Turn ignition switch OFF.
2. Check voltage between BCM connector M20 terminals 65, 66 and ground.

Connector	Terminals		Condition	Voltage (V) (Approx.)
	(+)	(-)		
M20	65	Ground	Door lock/unlock switch is turned to LOCK	0 → Battery voltage
	66		Door lock/unlock switch is turned to UNLOCK	0 → Battery voltage

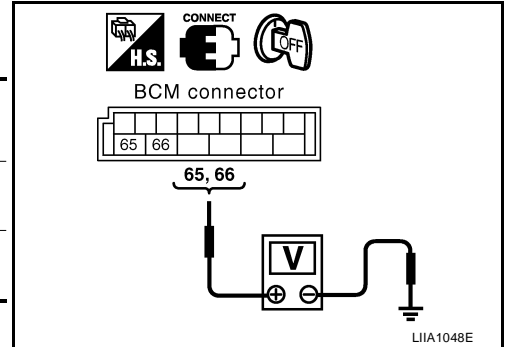

#### OK or NG

- OK >> GO TO 2.  
 NG >> Replace BCM. Refer to [BCS-26, "Removal and Installation of BCM"](#).

### 2. CHECK DOOR LOCK ACTUATOR HARNESS

1. Disconnect BCM and front door lock actuator RH.
2. Check continuity between BCM connector M20 terminals 65, 66 and front door lock actuator RH D114 terminals 1, 2.

Terminals		Continuity
65	2	Yes
66	1	Yes

3. Check continuity between BCM connector M19 terminals 65, 66 and ground.

Terminals		Continuity
65	Ground	No
66		No

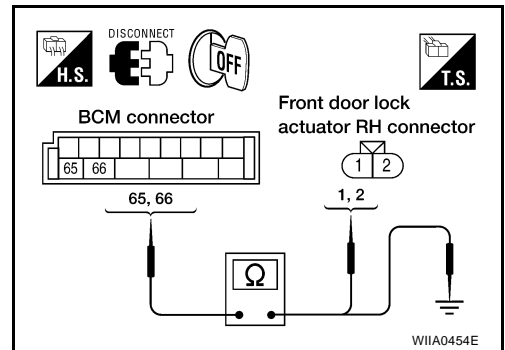

#### OK or NG

- OK >> Replace front door lock actuator RH. Refer to [BL-97, "Removal and Installation"](#).  
 NG >> Repair or replace harness.

# POWER DOOR LOCK SYSTEM

## Back Door Lock Actuator and Rear Door Lock Actuator RH/LH Check

EIS006C0

### 1. CHECK DOOR LOCK ACTUATOR SIGNAL

1. Turn ignition switch OFF.
2. Check voltage between BCM connector M20 terminals 65, 66 and ground.

Connector	Terminals		Condition	Voltage (V) (Approx.)
	(+)	(-)		
M20	65	Ground	Door lock/unlock switch is turned to LOCK	0 → Battery voltage
	66		Door lock/unlock switch is turned to UNLOCK	0 → Battery voltage

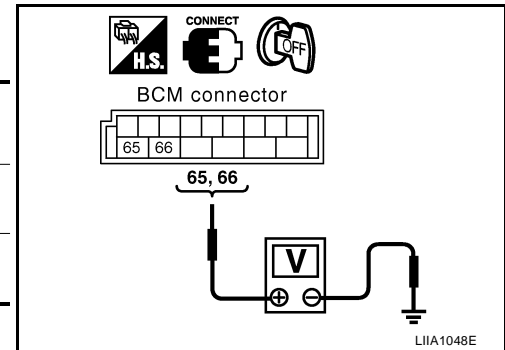

#### OK or NG

- OK >> GO TO 2.  
 NG >> Replace BCM. Refer to [BCS-26, "Removal and Installation of BCM"](#).

### 2. CHECK DOOR LOCK ACTUATOR HARNESS

1. Disconnect BCM and each door lock actuator.
2. Check continuity between BCM connector M20 terminals 65, 66 and rear door lock actuator RH/LH connectors D305, D205 terminals 1, 2 and back door lock actuator connector D508 terminals 2, 4.

Terminals		Continuity
65	2	Yes
66	1	Yes
66	4	Yes

3. Check continuity between BCM connector M20 terminals 65, 66 and ground.

Terminals		Continuity
65	Ground	No
66		No

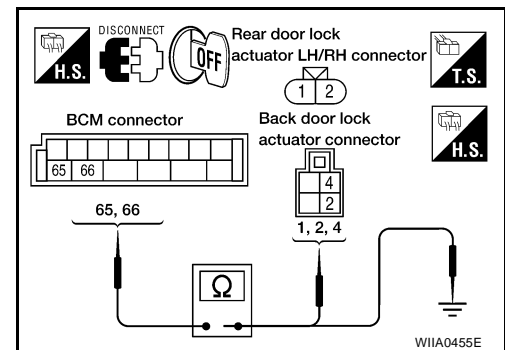

#### OK or NG

- OK >> Replace door lock actuator. Refer to [BL-101, "Component Structure"](#) (back door lock) or [BL-100, "Removal and Installation"](#) (rear door LH/RH).  
 NG >> Repair or replace harness.

# POWER DOOR LOCK SYSTEM

## Front Door Lock Assembly LH (Key Cylinder Switch) Check

EIS006C2

### 1. CHECK DOOR KEY CYLINDER SWITCH LH

☑ With CONSULT-II

Check front door lock assembly LH (key cylinder switch) ("KEY CYL LK-SW") and ("KEY CYL UN-SW") in DATA MONITOR mode in CONSULT-II. Refer to [BL-27, "DATA MONITOR"](#).

- When key inserted in front key cylinder is turned to LOCK:  
**KEY CYL LK-SW : ON**
- When key inserted in front key cylinder is turned to UNLOCK:  
**KEY CYL UN-SW : ON**

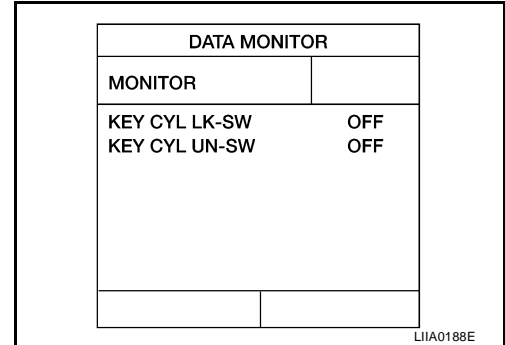

☒ Without CONSULT-II

Check voltage between BCM connector M18 terminals 7, 8 and ground.

Connector	Terminals		Condition	Voltage (V) (Approx.)
	(+)	(-)		
M18	7	Ground	Neutral/Lock	5
			Unlock	0
	8		Neutral/Unlock	5
			Lock	0

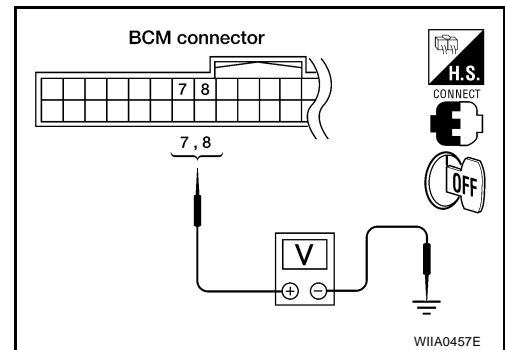

OK or NG

- OK >> Front door lock assembly LH (key cylinder switch) signal is OK.
- NG >> GO TO 2.

### 2. CHECK FRONT DOOR LOCK ASSEMBLY LH (KEY CYLINDER SWITCH)

- Turn ignition switch OFF.
- Disconnect front door lock assembly LH (key cylinder switch).
- Check continuity between front door lock assembly LH (key cylinder switch) connector terminals 3, 4 and 5.

Terminals	Condition	Continuity
4 - 5	Key is turned to LOCK.	Yes
	Key is in N position or turned to UNLOCK	No
3 - 4	Key is turned to UNLOCK.	Yes
	Key is in N position or turned to LOCK	No

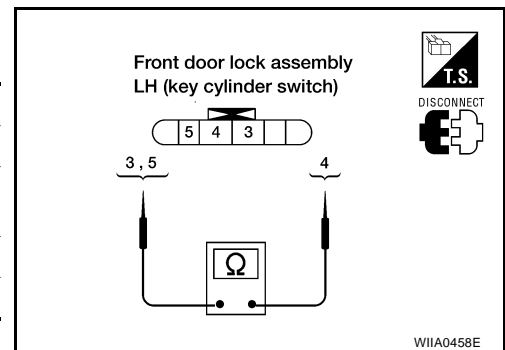

OK or NG

- OK >> GO TO 3.
- NG >> Replace front door lock assembly LH (key cylinder switch). Refer to [BL-97, "Removal and Installation"](#).

# POWER DOOR LOCK SYSTEM

## 3. CHECK FRONT DOOR LOCK ASSEMBLY LH HARNESS

1. Disconnect BCM.
2. Check continuity between BCM connector M18 terminals 7, 8 and front door lock assembly LH connector D14 terminals 3, 5.

**7 - 3** : Continuity should exist.

**8 - 5** : Continuity should exist.

3. Check continuity between BCM connector M18 terminals 7, 8 and ground.

**7 - Ground** : Continuity should not exist.

**8 - Ground** : Continuity should not exist.

OK or NG

OK >> GO TO 4.

NG >> Repair or replace harness.

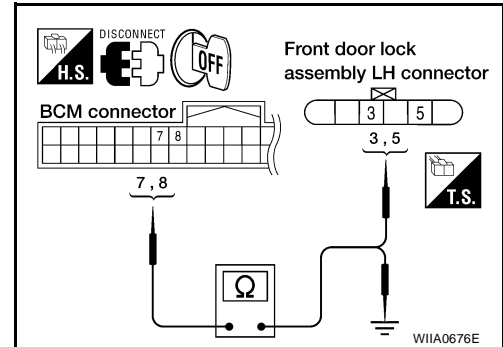

## 4. CHECK FRONT DOOR LOCK ASSEMBLY LH GROUND

Check continuity between front door lock assembly LH connector D14 terminal 4 and ground.

**4 - Ground** : Continuity should exist.

OK or NG

OK >> GO TO 5.

NG >> Repair or replace harness.

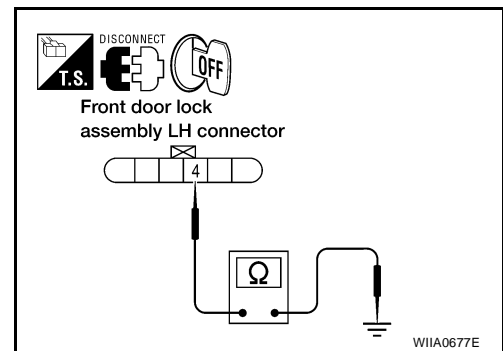

## 5. CHECK BCM OUTPUT VOLTAGE

1. Connect BCM.
2. Check voltage between BCM connector M18 terminals 7, 8 and ground.

**7 - Ground** : Approx. 5V

**8 - Ground** : Approx. 5V

OK or NG

OK >> Check condition of the harness and connector.

NG >> Replace BCM. Refer to [BCS-26, "Removal and Installation of BCM"](#).

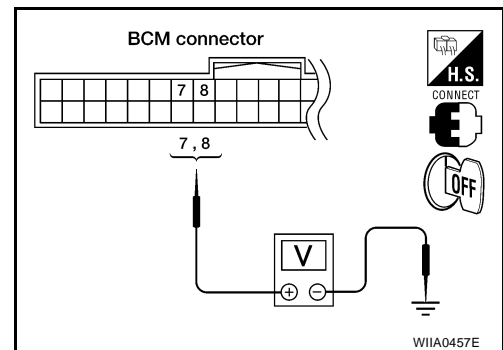



# POWER DOOR LOCK SYSTEM

EIS006VV

## Back Door Key Cylinder Switch Check

### 1. CHECK BACK DOOR KEY CYLINDER SWITCH

☑ With CONSULT-II

Check back door key cylinder switch ("KEY CYL LK-SW") and ("KEY CYL UN-SW") in DATA MONITOR mode in CONSULT-II. Refer to [BL-27, "DATA MONITOR"](#).

- When key inserted in back door key cylinder is turned to LOCK:

**KEY CYL LK-SW : ON**

- When key inserted in back door key cylinder is turned to UNLOCK:

**KEY CYL UN-SW : ON**

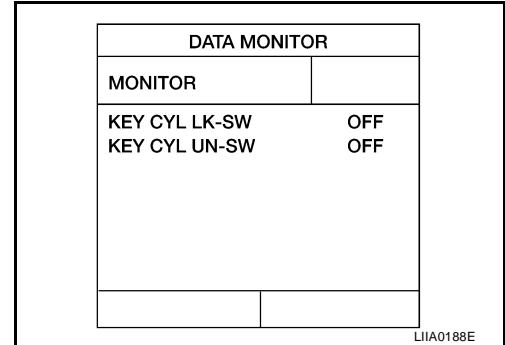

☒ Without CONSULT-II

Check voltage between BCM connector M18 terminals 7, 8 and ground.

Connector	Terminals		Condition	Voltage (V) (Approx.)
	(+)	(-)		
M18	7	Ground	Neutral/Lock	5
			Unlock	0
	8		Neutral/Unlock	5
			Lock	0

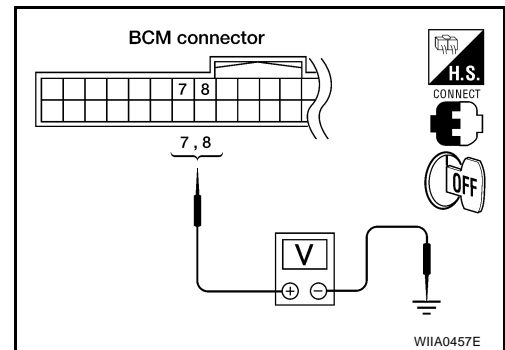

OK or NG

- OK >> Back door key cylinder switch signal is OK.
- NG >> GO TO 2.

### 2. CHECK BACK DOOR KEY CYLINDER SWITCH

- Turn ignition switch OFF.
- Disconnect back door key cylinder switch.
- Check continuity between back door key cylinder switch terminals 1, 2 and 3.

Terminals	Condition	Continuity
1 - 2	Key is turned to LOCK.	Yes
	Key is in N position or turned to UNLOCK	No
3 - 2	Key is turned to UNLOCK.	Yes
	Key is in N position or turned to LOCK	No

OK or NG

- OK >> GO TO 3.
- NG >> Replace back door key cylinder switch.

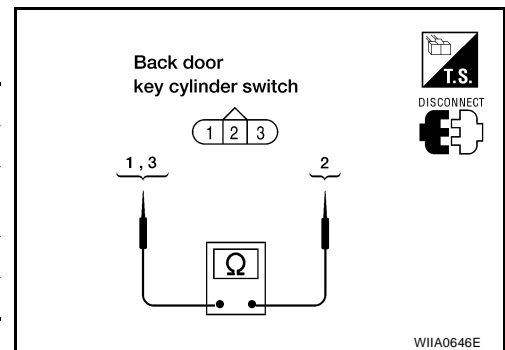

# POWER DOOR LOCK SYSTEM

## 3. CHECK BACK DOOR KEY CYLINDER SWITCH HARNESS

1. Disconnect BCM.
2. Check continuity between BCM connector M18 terminals 7, 8 and back door key cylinder switch connector D505 terminals 3, 1.

**7 - 3 : Continuity should exist.**

**8 - 1 : Continuity should exist.**

3. Check continuity between BCM connector M18 terminals 7, 8 and ground.

**7 - Ground : Continuity should not exist.**

**8 - Ground : Continuity should not exist.**

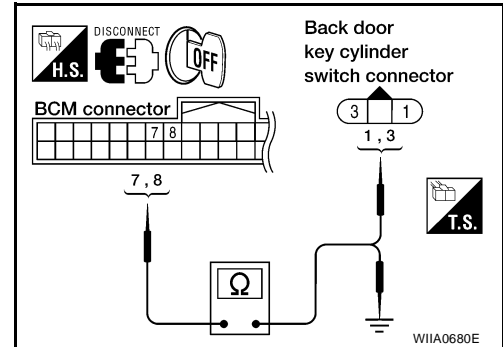

OK or NG

OK >> GO TO 4.

NG >> Repair or replace harness.

## 4. CHECK BACK DOOR KEY CYLINDER SWITCH GROUND

Check continuity between back door key cylinder switch connector D505 terminal 2 and ground.

**2 - Ground : Continuity should exist.**

OK or NG

OK >> GO TO 5.

NG >> Repair or replace harness.

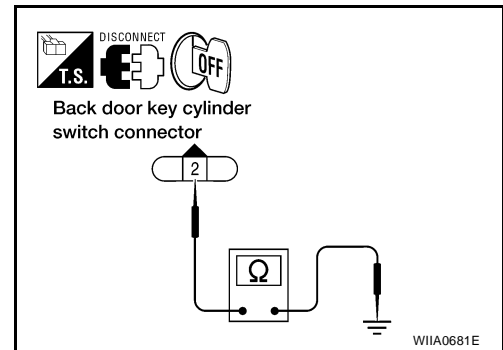

## 5. CHECK BCM OUTPUT VOLTAGE

1. Connect BCM.
2. Check voltage between BCM connector M18 terminals 7, 8 and ground.

**7 - Ground : Approx. 5V**

**8 - Ground : Approx. 5V**

OK or NG

OK >> Check condition of the harness and connector.

NG >> Replace BCM. Refer to [BCS-26, "Removal and Installation of BCM"](#).

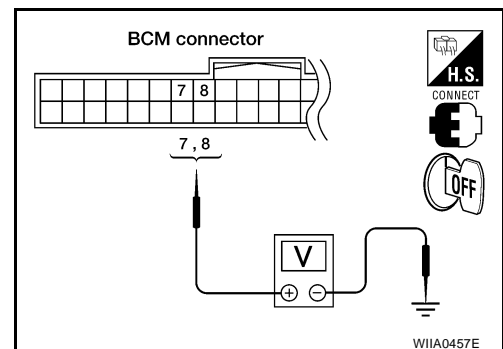

# REMOTE KEYLESS ENTRY SYSTEM

PFP:28596

EIS006C3

## REMOTE KEYLESS ENTRY SYSTEM

### Component Parts and Harness Connector Location

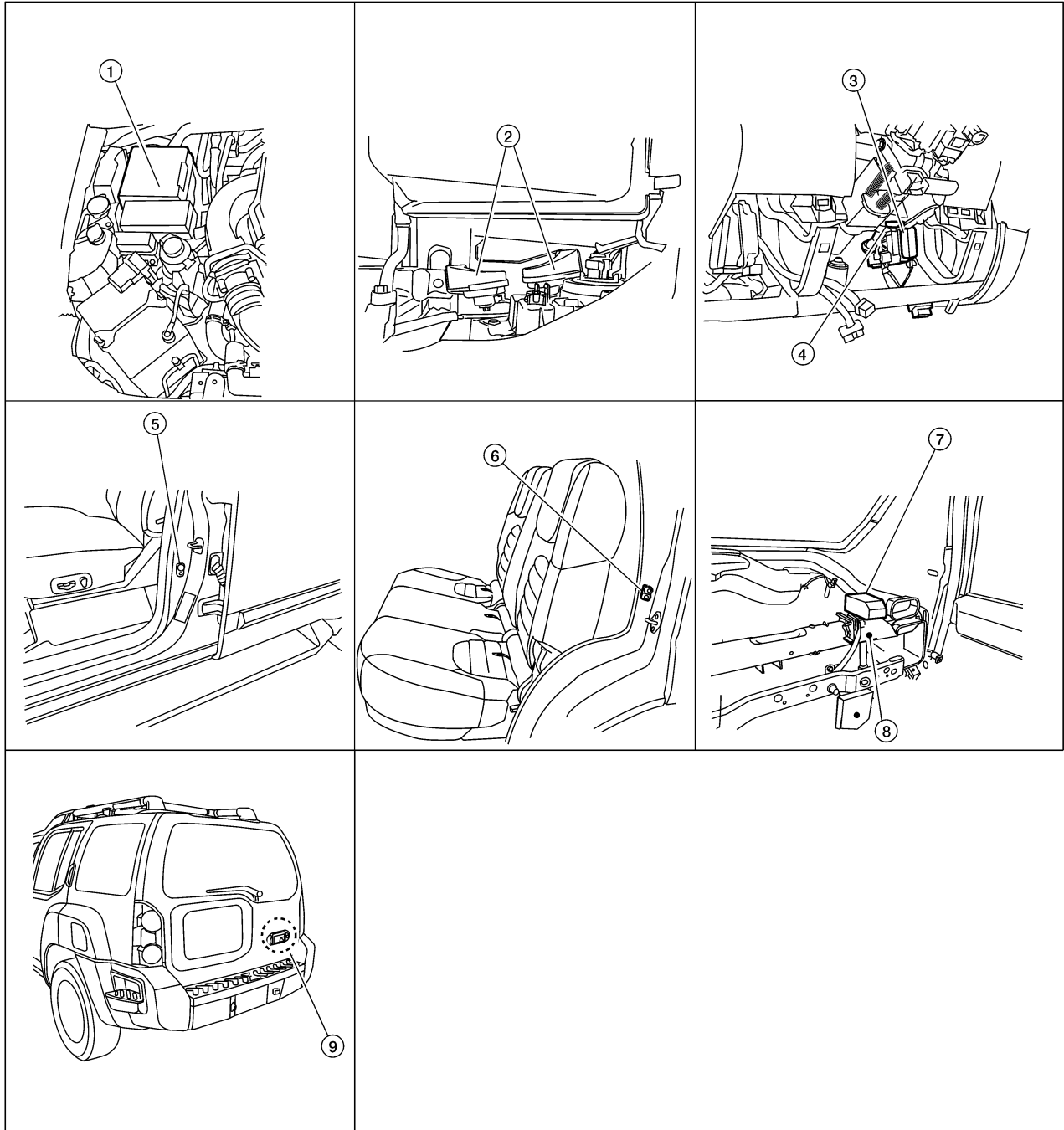

- |  |   |   |
|--|---|---|
| 1. IPDM E/R E122, E124   | 2. Horns E3, E162<br>(behind front combination lamp LH) | 3. BCM M18, M19, M20<br>(view with instrument lower panel LH removed) |
| 4. Key switch M27  | 5. Front door switch<br>LH B8<br>RH B108                | 6. Rear door switch<br>LH B18<br>RH B116                              |
| 7. Remote keyless entry receiver M120<br>(View with instrument panel RH removed) | 8. Steering member                                      | 9. Back door switch D502  |

LIA2426E

# REMOTE KEYLESS ENTRY SYSTEM

EIS006C4

## System Description

### INPUTS

Power is supplied at all times

- to BCM (body control module) terminal 70
- through 50A fusible link (letter **g** , located in the fuse and fusible link box).
- to BCM terminal 57
- through 10A fuse [No. 18, located in the fuse block (J/B)].

When the key is inserted in key switch, power is supplied

- to BCM terminal 37
- through key switch terminals 1 and 2
- through 10A fuse (No. 25, located in the fuse and fusible link box).

When the ignition switch is in ACC or ON, power is supplied

- to BCM terminal 11
- through 10A fuse [No. 4, located in the fuse block (J/B)].

When the ignition switch is ON or START, power is supplied

- to BCM terminal 38
- through 10A fuse [No. 1, located in the fuse block (J/B)].

When the front door switch LH is ON (door is OPEN), ground is supplied

- to BCM terminal 47
- through front door switch LH terminal 2
- through front door switch LH case ground.

When the front door switch RH is ON (door is OPEN), ground is supplied

- to BCM terminal 12
- through front door switch RH terminal 2
- through front door switch RH case ground.

When the rear door switch LH is ON (door is OPEN), ground is supplied

- to BCM terminal 48
- through rear door switch LH terminal 2
- through rear door switch LH case ground.

When the rear door switch RH is ON (door is OPEN), ground is supplied

- to BCM terminal 13
- through rear door switch RH terminal 2
- through rear door switch RH case ground.

When the back door switch is ON (door is OPEN), ground is supplied

- to BCM terminal 43
- through back door switch terminal 3,
- through back door switch terminal 1,
- through body grounds D406 and D652.

Keyfob signal is inputted to BCM from the remote keyless entry receiver.

The remote keyless entry system controls operation of the

- power door lock
- interior lamp and ignition keyhole illumination
- panic alarm
- hazard and horn reminder
- auto door lock operation

### OPERATED PROCEDURE

- When the keyfob is operated, the signal from the keyfob is sent and the remote keyless entry receiver receives the signal and sends it to the BCM. The BCM only locks/unlocks the doors if the ID number matches. (Remote control entry functions)

# REMOTE KEYLESS ENTRY SYSTEM

- Using the keyfob, the transmitter sends radio waves to the remote keyless entry receiver, which then sends the received waves to the BCM. Only if the ID number matches does the BCM lock/unlock the doors. (Remote control door function) A
- Unless the key is inserted into the ignition key cylinder or one of the doors is opened within 1 minute after the UNLOCK switch on the keyfob is pressed, all the doors are automatically locked. (Auto lock function) B
- When a door is locked or unlocked, the vehicle turn signal lamps flash and the horn sounds to verify operation. (Active check function) C
- When the key is in the ignition key cylinder (when the key switch is ON) and one of the doors is open, the door lock function does not work even when the door lock is operated with the keyfob.
- Keyfob ID set up is available.
- If a keyfob is lost, a new keyfob can be set up. A maximum of 5 IDs can be set up simultaneously. D

## Remote Control Entry Functions

### Operation Description

- When a button on the keyfob is operated, the signal is sent from the keyfob and received by the remote keyless entry receiver. E
- The received signal is sent to the BCM and compared with the registered ID number.
- If the ID number matches, the BCM sends the lock/unlock signal to each door lock actuator. F
- When the door lock actuators receive this signal, each operates to lock/unlock its door.
- BCM locks all doors with input of LOCK signal from keyfob. G
- When an UNLOCK signal is sent from keyfob once, driver's door will be unlocked.
- Then, if an UNLOCK signal is sent from keyfob again within 5 seconds, all other doors will be unlocked. H

### Remote control entry operation conditions

Keyfob operation	Operation condition
Door lock operation (locking)	<ul style="list-style-type: none"> <li>● With key removed (key switch: OFF)</li> <li>● Closing all doors (door switch: OFF)</li> </ul>
Door lock operation (unlocking)	With key removed (key switch: OFF)

## Auto Lock Function

### Operation Description

- Unless the key is inserted into the ignition key cylinder, one of the doors is opened, or the keyfob is operated within 1 minute after a door lock is unlocked by keyfob operation, all the doors are automatically locked. J
- The 1 minute timer count is executed by the BCM and after 1 minute, the BCM sends the lock signal to all doors. K
- Lock operations are the same as for the remote control entry function. L

## Active Check Function

### Operation Description

When a door is locked or unlocked by keyfob operation, the vehicle turn signals flash and the horn sounds to verify operation. M

- When a button on the keyfob is operated, the signal is sent from the remote controller and received by the keyless remote entry receiver.
- The received signal is sent to the BCM and compared with the registered ID number.
- If the ID number matches, the BCM uses communication to send the turn signal flashing and horn signal to the IPDM E/R.
- The IPDM E/R flashes the turn signal lamps and sounds the horn for each keyfob operation.

## Hazard and Horn Reminder

BCM output to IPDM E/R for horn reminder signal as DATA LINE (CAN H line and CAN L line).  
The hazard and horn reminder has C mode (horn chirp mode) and S mode (non-horn chirp mode).

# REMOTE KEYLESS ENTRY SYSTEM

## Operating function of hazard and horn reminder

	C mode		S mode	
	Lock	Unlock	Lock	Unlock
Remote controller operation	Lock	Unlock	Lock	Unlock
Hazard warning lamp flash	Twice	Once	Twice	—
Horn sound	Once	—	—	—

### How to change hazard and horn reminder mode

④ With CONSULT-II

Hazard and horn reminder can be changed using "WORK SUPPORT" mode in "MULTI ANSWER BACK SET".

⊗ Without CONSULT-II

Refer to Owner's Manual for instructions.

### Interior Lamp and Ignition Keyhole Illumination Operation

When the following input signals are both supplied:

- all door switches are in the OFF position. (when all the doors are closed);
- interior lamp switch is in DOOR position.

Remote keyless entry system turns on interior lamp and ignition keyhole illumination (for 30 seconds) with input of UNLOCK signal from keyfob.

For detailed description, refer to [LT-106, "System Description"](#).

### Panic Alarm Operation

When key switch is OFF (when ignition key is not inserted in key cylinder), remote keyless entry system turns on and off horn and headlamp intermittently with input of PANIC ALARM signal from keyfob.

The alarm automatically turns off after 25 seconds or when BCM receives any signal from keyfob.

### CAN Communication System Description

EIS006C5

Refer to [LAN-21, "CAN COMMUNICATION"](#).

# REMOTE KEYLESS ENTRY SYSTEM

## Schematic

EIS006C6

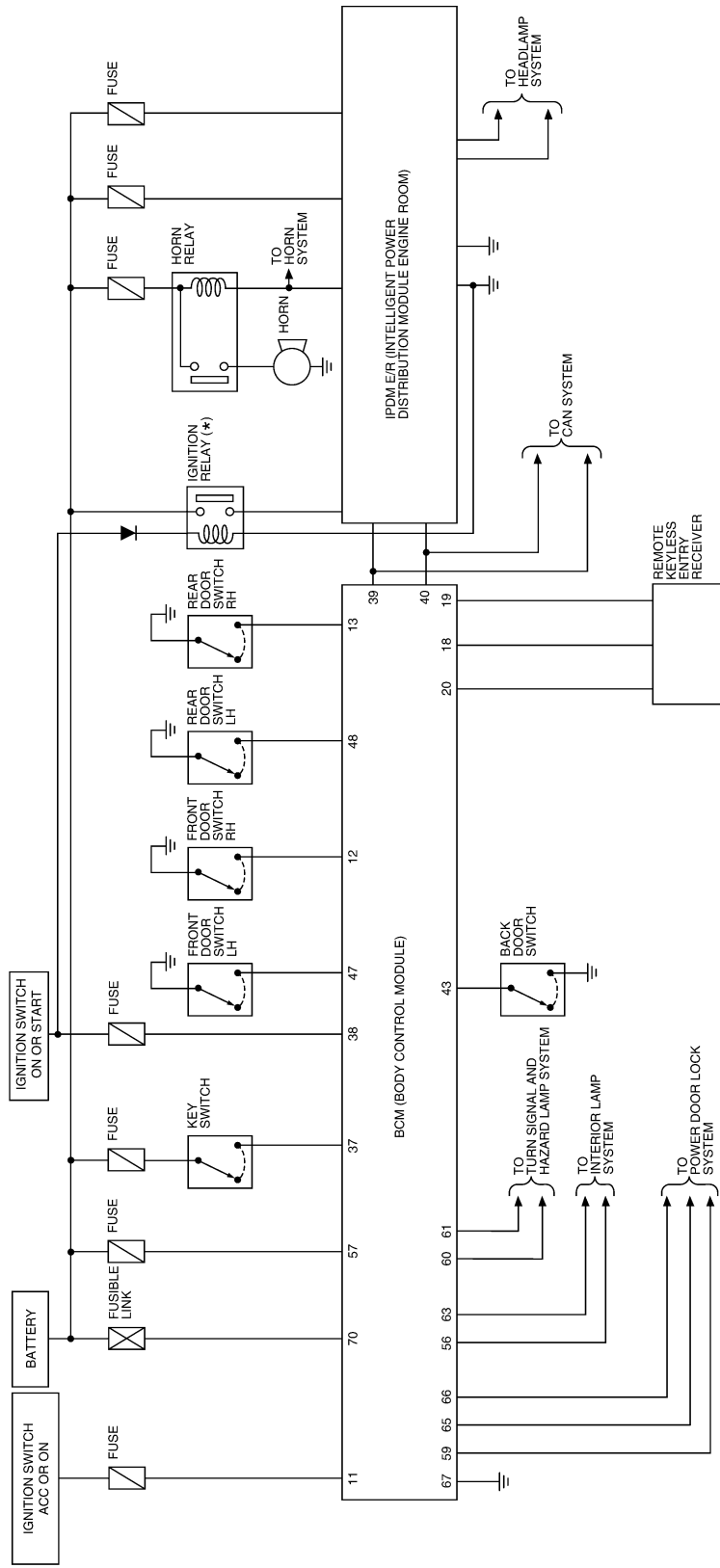

\* : THIS RELAY IS BUILT INTO THE IPDM/ER (INTELLIGENT POWER DISTRIBUTION MODULE ENGINE ROOM)

A  
B  
C  
D  
E  
F  
G  
H  
I  
J  
K  
L  
M

BL

# REMOTE KEYLESS ENTRY SYSTEM

## Wiring Diagram — KEYLES —

EIS006C7

### BL-KEYLES-01

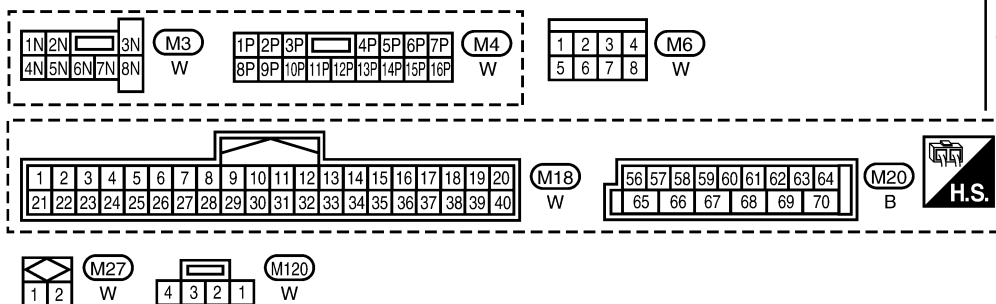
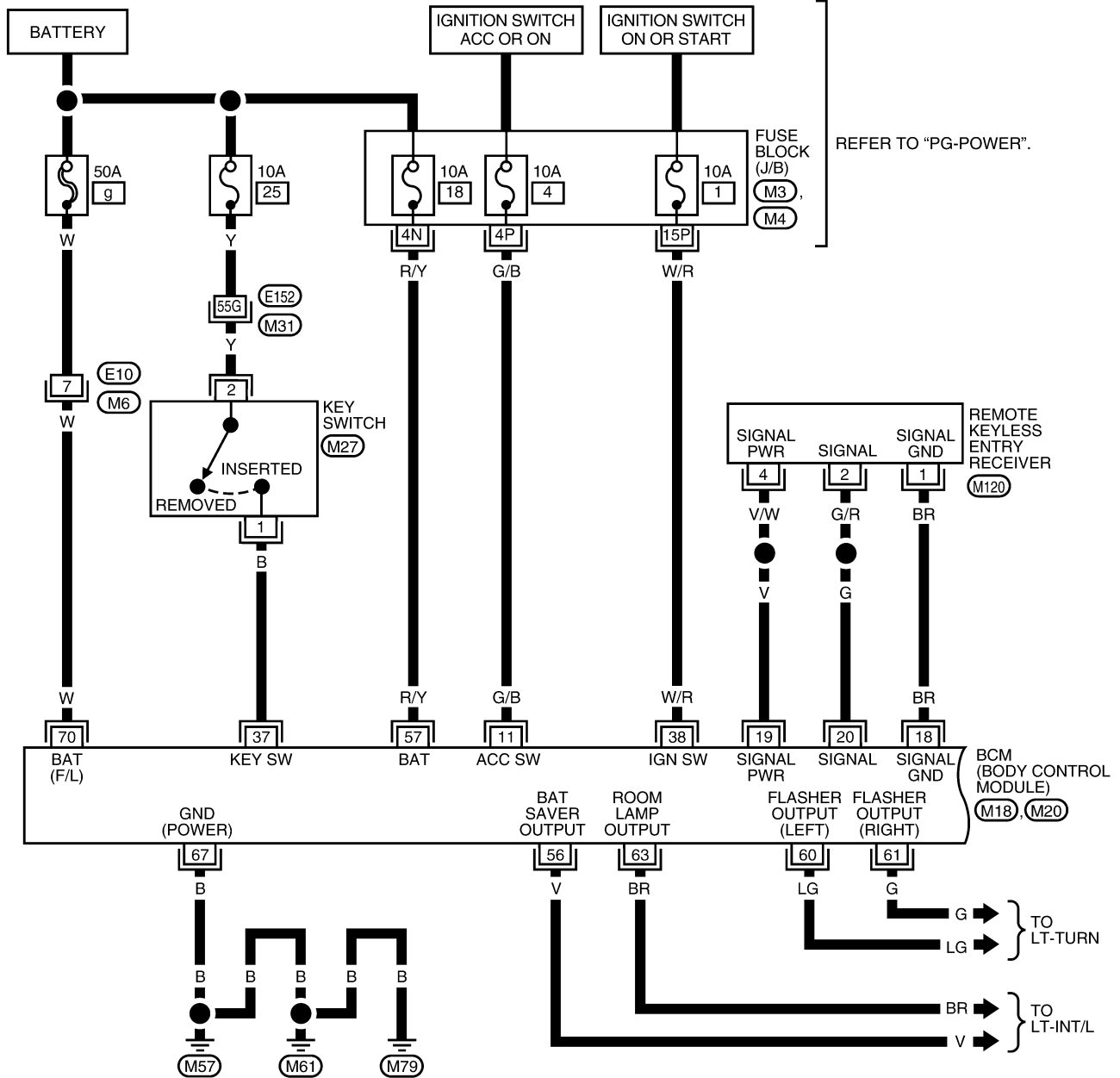

WIWA1690E



# REMOTE KEYLESS ENTRY SYSTEM

BL-KEYLES-02

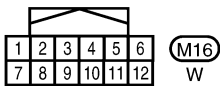
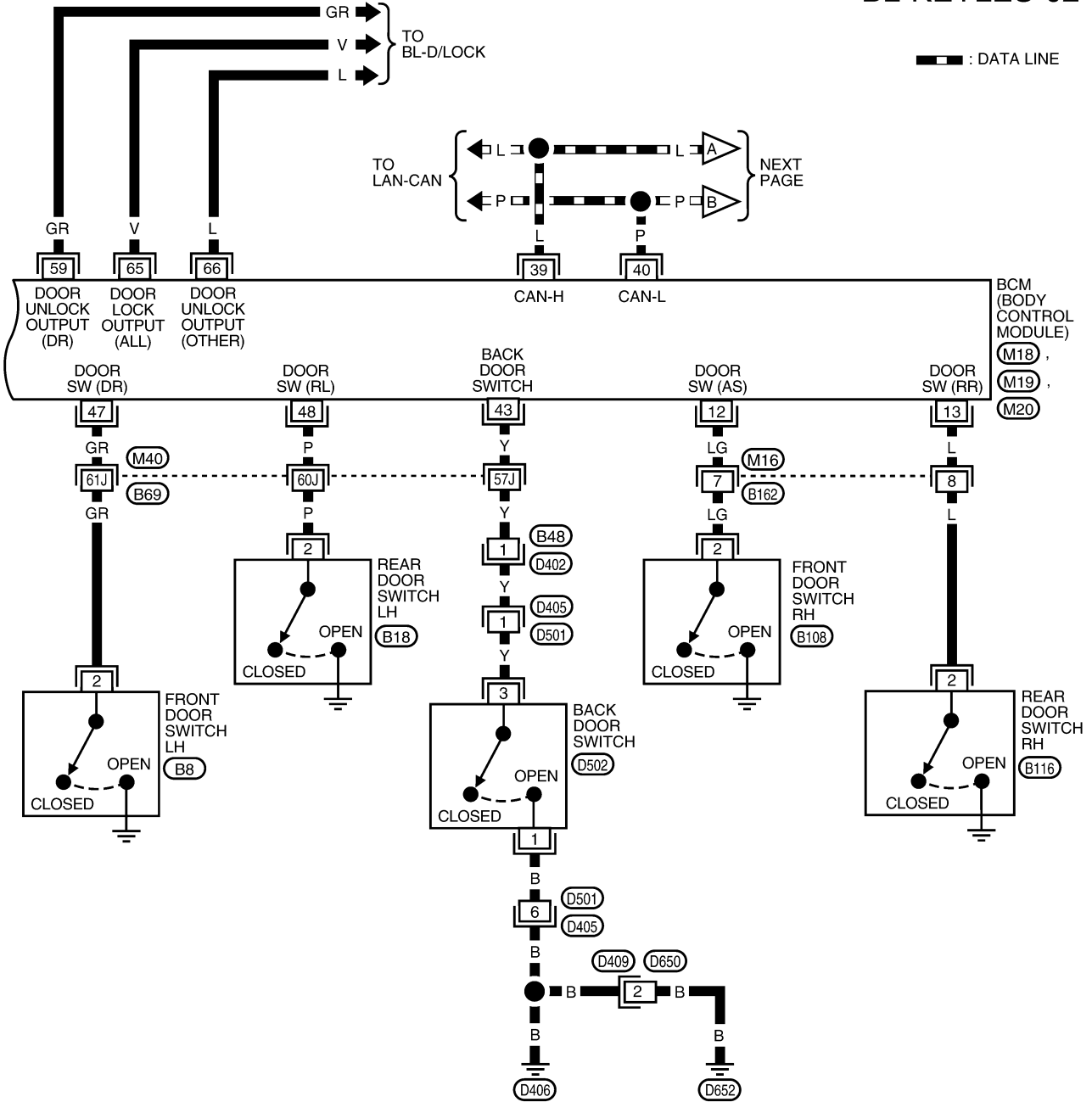

REFER TO THE FOLLOWING.  
 (M40) - SUPER MULTIPLE JUNCTION (SMJ)

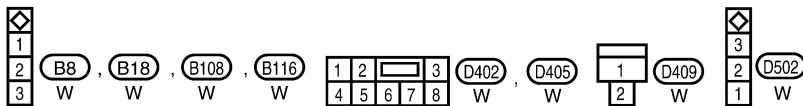
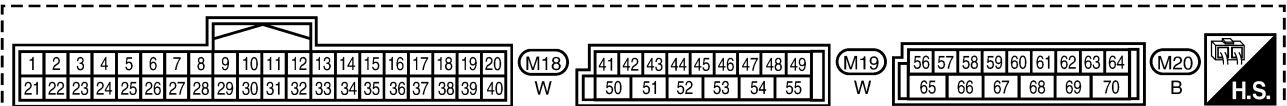

WIWA1691E

# REMOTE KEYLESS ENTRY SYSTEM

## BL-KEYLES-03

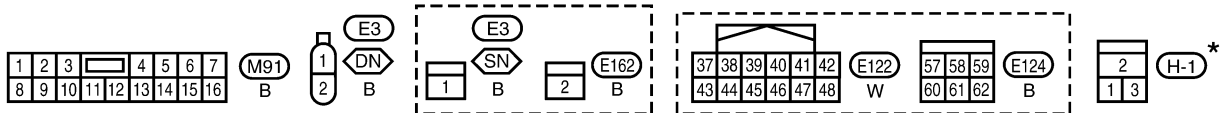
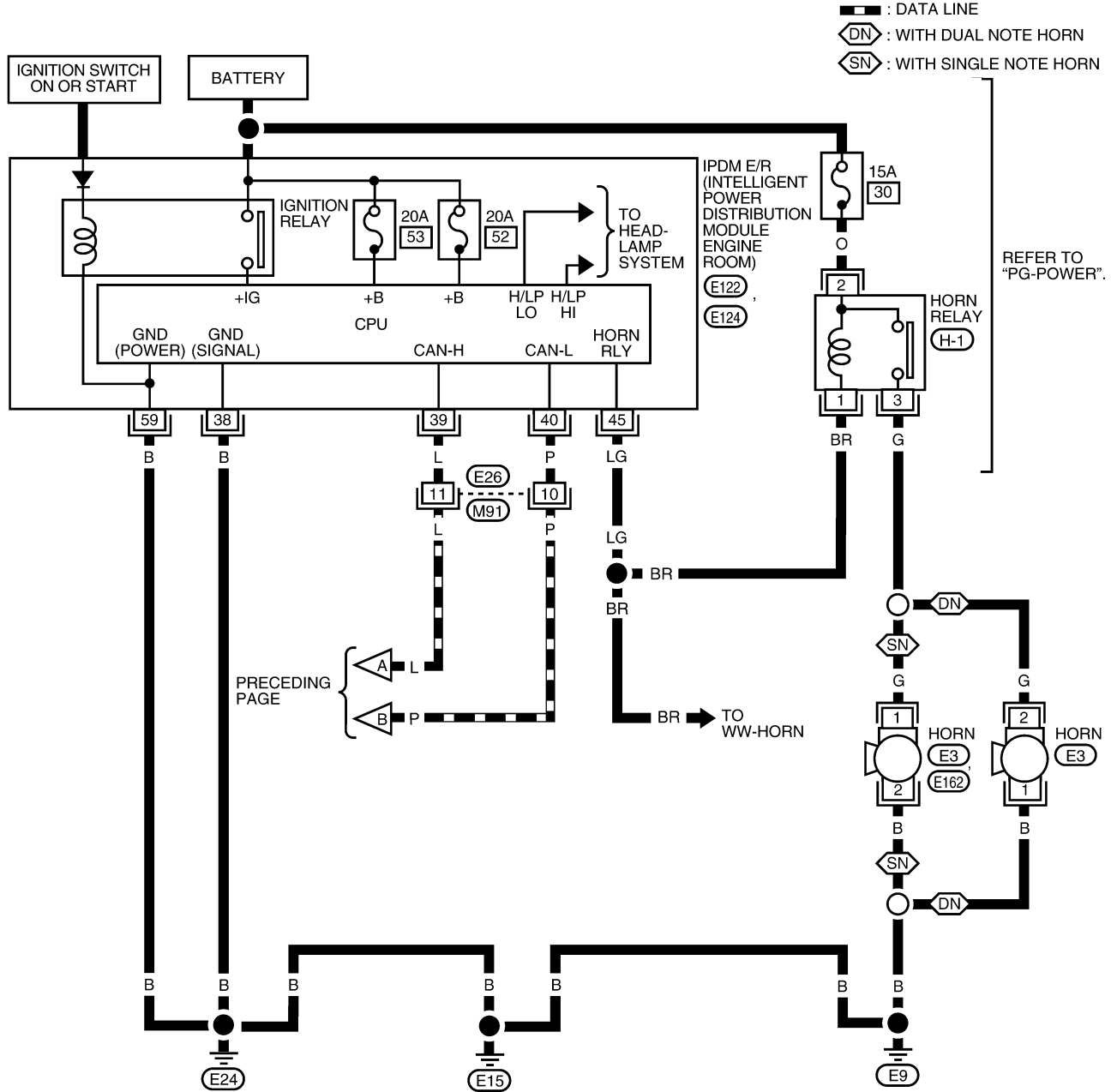

\*: THIS CONNECTOR IS NOT SHOWN IN "HARNESS LAYOUT" OF PG SECTION.

WIWA1692E

# REMOTE KEYLESS ENTRY SYSTEM

## Terminals and Reference Value for BCM

EIS006C8

Refer to [BCS-12, "Terminals and Reference Values for BCM"](#).

## Terminals and Reference Value for IPDM E/R

EIS006C9

Refer to [PG-29, "Terminals and Reference Values for IPDM E/R"](#).

## CONSULT-II Function (BCM)

EIS006CA

CONSULT-II can display each diagnostic item using the diagnostic test modes shown following.

BCM diagnostic test item	Diagnostic mode	Description
Inspection by part	WORK SUPPORT	Supports inspections and adjustments. Commands are transmitted to the BCM for setting the status suitable for required operation, input/output signals are received from the BCM and received data is displayed.
	DATA MONITOR	Displays BCM input/output data in real time.
	ACTIVE TEST	Operation of electrical loads can be checked by sending drive signal to them.
	SELF-DIAG RESULTS	Displays BCM self-diagnosis results.
	CAN DIAG SUPPORT MNTR	The result of transmit/receive diagnosis of CAN communication can be read.
	ECU PART NUMBER	BCM part number can be read.
	CONFIGURATION	Performs BCM configuration read/write functions.

## CONSULT-II Inspection Procedure "MULTI REMOTE ENT"

EIS006CB

### CAUTION:

If CONSULT-II is used with no connection of CONSULT-II CONVERTER, malfunctions might be detected in self-diagnosis depending on control unit which carries out CAN communication.

1. Turn ignition switch OFF.
2. Connect CONSULT-II and CONSULT-II CONVERTER to the data link connector.

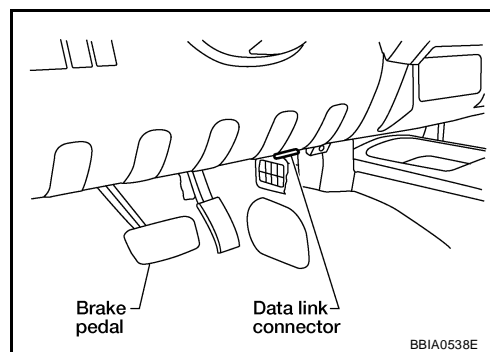

3. Turn ignition switch ON.
4. Touch "START (NISSAN BASED VHCL)".

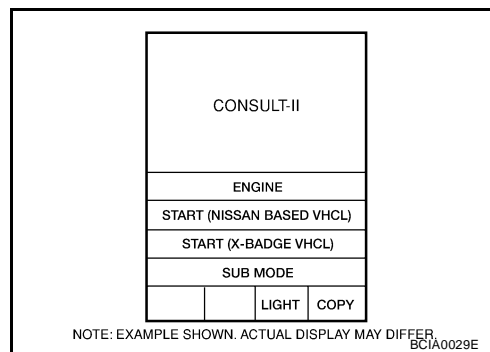

# REMOTE KEYLESS ENTRY SYSTEM

5. Touch "BCM".  
If "BCM" is not indicated, refer to [GI-41, "CONSULT-II Data Link Connector \(DLC\) Circuit"](#).

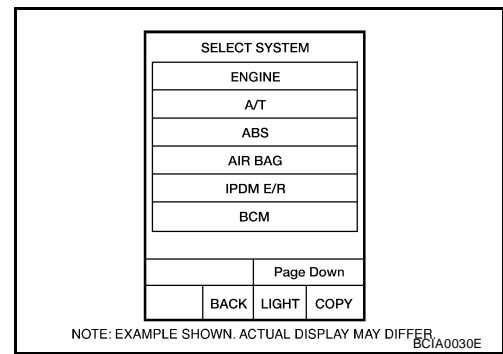

6. Touch "MULTI REMOTE ENT".

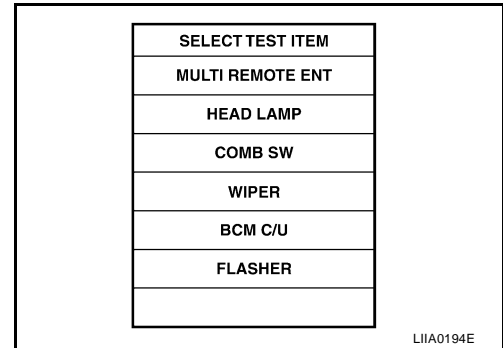

7. Select diagnosis mode.  
"DATA MONITOR", "ACTIVE TEST" and "WORK SUPPORT" are available.

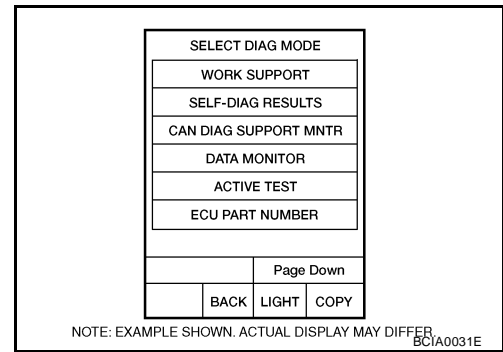

## CONSULT-II Application Items "MULTI REMOTE ENT"

EIS006CC

### Data Monitor

Monitored Item	Description
DOOR SW-AS	Indicates [ON/OFF] condition of front door switch RH.
DOOR SW-RR	Indicates [ON/OFF] condition of rear door switch RH.
DOOR SW-RL	Indicates [ON/OFF] condition of rear door switch LH.
DOOR SW-DR	Indicates [ON/OFF] condition of front door switch LH.
BACK DOOR SW	Indicates [ON/OFF] condition of back door switch.
KEY ON SW	Indicates [ON/OFF] condition of key switch.
ACC ON SW	Indicates [ON/OFF] condition of ignition switch in ACC position.
IGN ON SW	Indicates [ON/OFF] condition of ignition switch in ON position.
KEYLESS PANIC	Indicates [ON/OFF] condition of panic signal from keyfob.
KEYLESS UNLOCK	Indicates [ON/OFF] condition of unlock signal from keyfob.
KEYLESS LOCK	Indicates [ON/OFF] condition of lock signal from keyfob.
KEY CYL LK-SW	Indicates [ON/OFF] condition of lock signal from door key cylinder switch.
CDL UNLOCK SW	Indicates [ON/OFF] condition of unlock signal from lock/unlock switch.
CDL LOCK SW	Indicates [ON/OFF] condition of lock signal from lock/unlock switch.

# REMOTE KEYLESS ENTRY SYSTEM

Monitored Item	Description
RKE LCK-UNLCK	Indicates [ON/OFF] condition of lock/unlock signal at the same time from keyfob.
RKE KEEP UNLK	Indicates [ON/OFF] condition of unlock signal from keyfob.

## Active Test

Test Item	Description
FLASHER	This test is able to check right and left hazard reminder operation. The right hazard lamp turns on when "RH" on CONSULT-II screen is touched and the left hazard lamp turns on when "LH" on CONSULT-II screen is touched.
HORN	This test is able to check panic alarm and horn reminder operations. The alarm activate for 0.5 seconds after "ON" on CONSULT-II screen is touched.
DOOR LOCK	This test is able to check door lock operation. The doors lock and unlock based on the item on CONSULT-II screen touched.

## Work Support

Test Item	Description
REMO CONT ID REGIST	Keyfob ID code can be registered.
REMO CONT ID ERASUR	Keyfob ID code can be erased.
REMO CONT ID CONFIR	It can be checked whether keyfob ID code is registered or not in this mode.
HORN CHIRP SET*	Horn chirp function mode can be changed in this mode. The function mode will be changed when "CHANG SETT" on CONSULT-II screen is touched.
HAZARD LAMP SET*	Hazard lamp function mode can be changed in this mode. The function mode will be changed when "CHANG SETT" on CONSULT-II screen is touched.
MULTI ANSWER BACK SET	Hazard and horn reminder mode can be changed in this mode. The reminder mode will be changed when "CHANG SETT" on CONSULT-II screen is touched.
AUTO LOCK SET	Auto locking function mode can be changed in this mode. The function mode will be changed when "CHANG SETT" on CONSULT-II screen is touched.
PANIC ALRM SET	Panic alarm operation mode can be changed in this mode. The operation mode will be changed when "CHANG SETT" on CONSULT-II screen is touched.

\*: Perform this mode always in the state of C mode. Refer to [BL-45, "Hazard and Horn Reminder"](#) .

### HORN CHIRP SET\*

Horn chirp function	ON	OFF

\*: Perform this mode always in the state of C mode. Refer to [BL-45, "Hazard and Horn Reminder"](#) .

### HAZARD LAMP BACK SET\*

	MODE1	MODE2	MODE3	MODE4
Hazard lamp operation mode	Nothing	Unlock only	Lock only	Lock and Unlock

\*: Perform this mode always in the state of C mode. Refer to [BL-45, "Hazard and Horn Reminder"](#) .

# REMOTE KEYLESS ENTRY SYSTEM

## MULTI ANSWER BACK SET

	MODE 1 (C mode)		MODE 2 (S mode)	
	Lock	Unlock	Lock	Unlock
Keyfob operation	Lock	Unlock	Lock	Unlock
Hazard warning lamp flash	Twice	Once	Twice	—
Horn sound	Once	—	—	—

## AUTO LOCK SET

	MODE 1	MODE 2	MODE 3
Auto locking function	1 minutes	Nothing	5 minutes

## PANIC ALARM SET

	MODE 1	MODE 2	MODE 3
Keyfob operation	0.5 seconds	Nothing	1.5 seconds

# REMOTE KEYLESS ENTRY SYSTEM

## Trouble Diagnosis Procedure

EIS006CD

1. Check the symptom and customer's requests.
2. Understand outline of system. Refer to [BL-44, "System Description"](#) .
3. Confirm system operation.
  - Check that the power door lock system operates normally. Refer to [BL-16, "POWER DOOR LOCK SYSTEM"](#) .
4. Perform pre-diagnosis inspection. Refer to [BL-55, "Pre-Diagnosis Inspection"](#) .
5. Refer to trouble diagnosis chart by symptom, repair or replace any malfunctioning parts. Refer to [BL-55, "Trouble Diagnoses"](#) .
6. Inspection End.

## Pre-Diagnosis Inspection

EIS006CE

### BCM POWER SUPPLY AND GROUND CIRCUIT INSPECTION

Refer to [BCS-16, "BCM Power Supply and Ground Circuit Check"](#) .

## Trouble Diagnoses SYMPTOM CHART

EIS006CF

### NOTE:

- Always check the "Trouble Diagnosis Procedure" before troubleshooting. Refer to [BL-55, "Trouble Diagnosis Procedure"](#) .
- Always check keyfob battery before replacing keyfob. Refer to [BL-60, "Keyfob Battery and Function Check"](#) .
- The panic alarm operation of remote keyless entry system does not activate with the ignition key inserted in the ignition key cylinder.
- Use Remote Keyless Entry Tester J-43241 (follow instructions on tester) to check operation of keyfob before replacing keyfob.

Symptom	Diagnoses/service procedure	Reference page
All function of remote keyless entry system do not operate.	1. Keyfob battery and function check (use Remote Keyless Entry Tester J-43241) <b>NOTE:</b> If the result of keyfob function check is OK, keyfob is not malfunctioning.	<a href="#">BL-60</a>
	2. Check BCM and remote keyless entry receiver.	<a href="#">BL-61</a>
The new ID of keyfob cannot be entered.	1. Keyfob battery and function check (use Remote Keyless Entry Tester J-43241) <b>NOTE:</b> If the result of keyfob function check is OK, keyfob is not malfunctioning.	<a href="#">BL-60</a>
	2. Key switch (insert) check	<a href="#">BL-57</a>
	3. Door switch check	<a href="#">BL-58</a>
	4. ACC power check	<a href="#">BL-63</a>
	5. Replace BCM.	<a href="#">BCS-26</a>
Door lock or unlock does not function. (If the power door lock system does not operate manually, check power door lock system. Refer to <a href="#">BL-16, "POWER DOOR LOCK SYSTEM"</a> .)	1. Keyfob battery and function check (use Remote Keyless Entry Tester J-43241) <b>NOTE:</b> If the result of keyfob function check is OK, keyfob is not malfunctioning.	<a href="#">BL-60</a>
	2. Replace BCM.	<a href="#">BCS-26</a>

# REMOTE KEYLESS ENTRY SYSTEM

Symptom	Diagnoses/service procedure	Reference page
Hazard and horn reminder does not activate properly when pressing lock or unlock button of keyfob.	1. Check hazard and horn reminder mode with CONSULT-II. <b>NOTE:</b> Hazard and horn reminder mode can be changed. First check the hazard and horn reminder mode setting.	<a href="#">BL-53</a>
	2. Door switch check	<a href="#">BL-58</a>
	3. Replace BCM.	<a href="#">BCS-26</a>
Hazard reminder does not activate properly when pressing lock or unlock button of keyfob. (Horn reminder OK)	1. Check hazard reminder mode with CONSULT-II. <b>NOTE:</b> Hazard reminder mode can be changed. First check the hazard reminder mode setting.	<a href="#">BL-53</a>
	2. Check hazard function with hazard switch.	—
	3. Replace BCM.	<a href="#">BCS-26</a>
Horn reminder does not activate properly when pressing lock or unlock button of keyfob. (Hazard reminder OK)	1. Check horn reminder mode with CONSULT-II. <b>NOTE:</b> Horn reminder mode can be changed. First check the horn reminder mode setting.	<a href="#">BL-53</a>
	2. Check horn function with horn switch.	—
	3. IPDM E/R operation check	<a href="#">BL-63</a>
	4. Replace BCM.	<a href="#">BCS-26</a>
Room lamp and ignition keyhole illumination operation do not activate properly.	1. Room lamp operation check	<a href="#">BL-64</a>
	2. Ignition keyhole illumination operation check	<a href="#">BL-64</a>
	3. Door switch check	<a href="#">BL-58</a>
	4. Replace BCM.	<a href="#">BCS-26</a>
Panic alarm (horn and headlamp) does not activate when panic alarm button is continuously pressed.	1. Keyfob battery and function check (use Remote Keyless Entry Tester J-43241) <b>NOTE:</b> If the result of keyfob function check is OK, keyfob is not malfunctioning.	<a href="#">BL-60</a>
	2. Key switch (insert) check	<a href="#">BL-57</a>
	3. Replace BCM.	<a href="#">BCS-26</a>
Auto door lock operation does not activate properly. (All other remote keyless entry functions OK.)	1. Check auto door lock operation mode with CONSULT-II. <b>NOTE:</b> Auto door lock operation mode can be changed. First check the auto door lock operation mode setting.	<a href="#">BL-53</a>
	2. Replace BCM.	<a href="#">BCS-26</a>



# REMOTE KEYLESS ENTRY SYSTEM

EIS006CG

## Key Switch (Insert) Check

### 1. CHECK KEY SWITCH INPUT SIGNAL

 With CONSULT-II

Check key switch "KEY ON SW" in DATA MONITOR mode with CONSULT-II. Refer to [BL-27, "DATA MONITOR"](#).

- When key is inserted to ignition key cylinder:  
**KEY ON SW : ON**
- When key is removed from ignition key cylinder:  
**KEY ON SW : OFF**

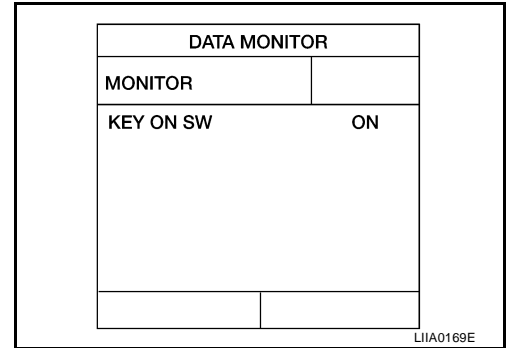

 Without CONSULT-II

Check voltage between BCM connector M18 terminal 37 and ground.

Connector	Terminal		Condition	Voltage (V)
	(+)	(-)		
M18	37	Ground	Key is inserted.	Battery voltage
			Key is removed.	0

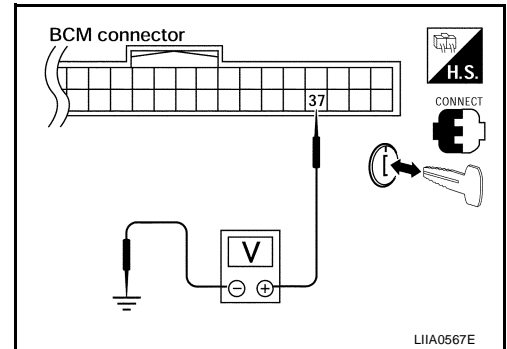

OK or NG

- OK >> Key switch (insert) circuit is OK.
- NG >> GO TO 2.

### 2. CHECK KEY SWITCH (INSERT)

- Turn ignition switch OFF.
- Disconnect key switch connector.
- Check continuity between key switch terminals.

Terminals	Condition	Continuity
1 - 2	Key is inserted.	Yes
	Key is removed.	No

OK or NG

- OK >> Repair or replace harness.
- NG >> Replace key switch.

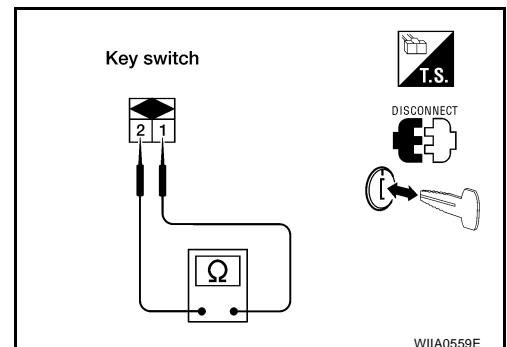

# REMOTE KEYLESS ENTRY SYSTEM

EIS006CH

## Door Switch Check

### 1. CHECK DOOR SWITCHES INPUT SIGNAL

 With CONSULT-II

Check door switches ("DOOR SW-DR", "DOOR SW-AS", "DOOR SW-RL", "DOOR SW-RR", "BACK DOOR SW") in DATA MONITOR mode with CONSULT-II. Refer to [BL-27, "DATA MONITOR"](#).

- When doors are open:

**DOOR SW-DR : ON**  
**DOOR SW-AS : ON**  
**DOOR SW-RL : ON**  
**DOOR SW-RR : ON**  
**BACK DOOR SW : ON**

- When doors are closed:

**DOOR SW-DR : OFF**  
**DOOR SW-AS : OFF**  
**DOOR SW-RL : OFF**  
**DOOR SW-RR : OFF**  
**BACK DOOR SW : OFF**

DATA MONITOR	
MONITOR	
DOOR SW - DR	OFF
DOOR SW - AS	OFF
DOOR SW - RR	OFF
DOOR SW - RL	OFF
BACK DOOR SW	OFF

LIA0665E

 Without CONSULT-II

Check voltage between BCM connector M18 or M19 terminals 12, 13, 43, 47, 48 and ground.

Connector	Item	Terminals		Condition	Voltage (V) (Approx.)
		(+)	(-)		
M19	Back door switch	43	Ground	Open ↓ Closed	0 ↓ Battery voltage
	Front door switch LH	47			
	Rear door switch LH	48			
M18	Front door switch RH	12	Ground	Open ↓ Closed	0 ↓ Battery voltage
	Rear door switch RH	13			

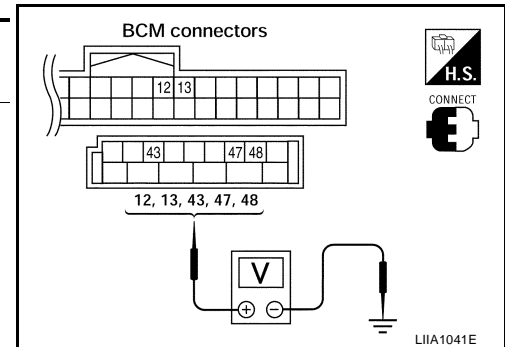

#### OK or NG

- OK >> Door switch circuit is OK.  
 NG >> GO TO 2.

# REMOTE KEYLESS ENTRY SYSTEM

## 2. CHECK BCM OUTPUT VOLTAGE

1. Turn ignition switch OFF.
2. Disconnect door switches.
3. Check voltage between BCM connector M18, M19 terminals 12, 13, 43, 47, 48 and ground.

<b>12 - Ground</b>	<b>: Battery voltage</b>
<b>13 - Ground</b>	<b>: Battery voltage</b>
<b>43 - Ground</b>	<b>: Battery voltage</b>
<b>47 - Ground</b>	<b>: Battery voltage</b>
<b>48 - Ground</b>	<b>: Battery voltage</b>

OK or NG

OK >> GO TO 3.

NG >> Replace BCM. Refer to [BCS-26, "Removal and Installation of BCM"](#).

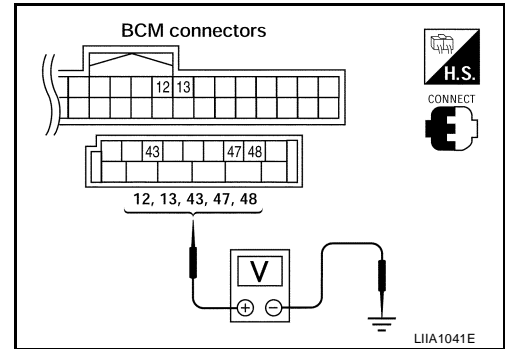

## 3. CHECK DOOR SWITCH CIRCUIT

1. Turn ignition switch OFF.
2. Disconnect door switch and BCM.
3. Check continuity between door switch connector B8 (Front LH), B108 (Front RH), B18 (Rear LH), B116 (Rear RH) terminal 2 or D502 (Back) terminal 3 and BCM connector M18, M19 terminals 12, 13, 43, 47 and 48.

<b>2 - 47</b>	<b>: Continuity should exist.</b>
<b>2 - 12</b>	<b>: Continuity should exist.</b>
<b>2 - 48</b>	<b>: Continuity should exist.</b>
<b>2 - 13</b>	<b>: Continuity should exist.</b>
<b>3 - 43</b>	<b>: Continuity should exist.</b>

4. Check continuity between door switch connector B8 (Front LH), B108 (Front RH), B18 (Rear LH), B116 (Rear RH) terminal 2 or D502 (Back) terminal 3 and ground.

<b>2 - Ground</b>	<b>: Continuity should not exist.</b>
<b>3 - Ground</b>	<b>: Continuity should not exist.</b>

OK or NG

OK >> GO TO 4.

NG >> Repair or replace harness.

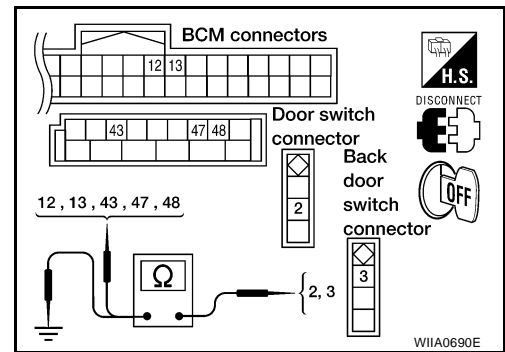

# REMOTE KEYLESS ENTRY SYSTEM

## 4. CHECK DOOR SWITCHES

### FRONT AND REAR DOORS

Check continuity between front or rear door switch terminal 2 and exposed metal of switch while pressing and releasing switch.

**When front or rear door switch is released : Continuity should exist.**

**When front or rear door switch is pushed : Continuity should not exist.**

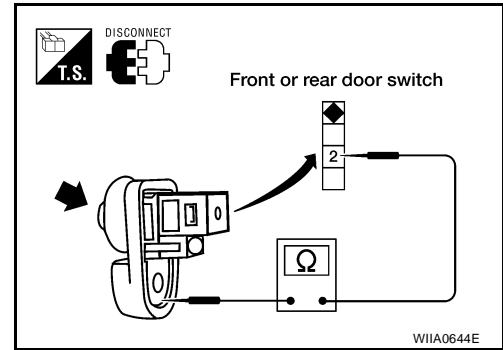

### BACK DOOR

Check continuity between back door switch terminals 3 and 1 while pressing and releasing switch.

**When back door switch is released : Continuity should exist.**

**When back door switch is pushed : Continuity should not exist.**

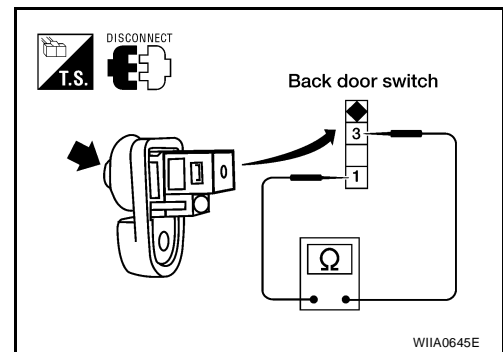

### OK or NG

- OK >> Check switch case ground condition (front and rear door) or ground circuit (back door).
- NG >> Replace door switch.

## Keyfob Battery and Function Check

### 1. CHECK KEYFOB BATTERY

Remove battery and measure voltage across battery positive and negative terminals, (+) and (-).

**Voltage : 2.5V - 3.0V**

### NOTE:

Keyfob does not function if battery is not set correctly.

### OK or NG

- OK >> GO TO 2.
- NG >> Replace battery.

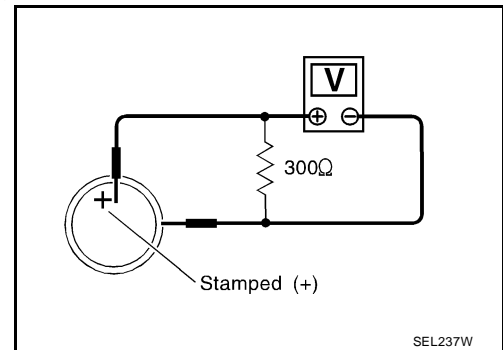

# REMOTE KEYLESS ENTRY SYSTEM

## 2. CHECK KEYFOB FUNCTION

### With CONSULT-II

Check keyfob function in "DATA MONITOR" mode with CONSULT-II. When pushing each button of keyfob, the corresponding monitor item should be turned as follows.

Condition	Monitor item
Pushing LOCK	KEYLESS LOCK : ON
Pushing UNLOCK	KEYLESS UNLOCK : ON
Keep pushing UNLOCK	RKE KEEP UNLK turns to ON 3 seconds after UNLOCK button is pushed.
Pushing PANIC	KEYLESS PANIC : ON
Pushing LOCK and UNLOCK at the same time	RKE LCK-UNLCK : ON

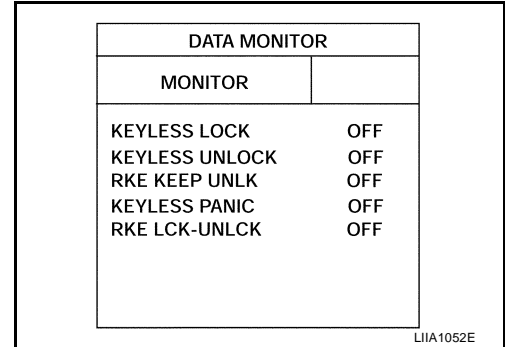

### Without CONSULT-II

Check keyfob function using Remote Keyless Entry Tester J-43241.

OK or NG

- OK >> WITH CONSULT-II: Keyfob, remote keyless entry receiver and wiring harness between BCM and remote keyless entry receiver are OK. Replace BCM. Refer to [BCS-26, "Removal and Installation of BCM"](#).
- OK >> WITHOUT CONSULT-II: Keyfob is OK. Further inspection is necessary. Refer to [BL-55, "SYMPTOM CHART"](#).
- NG >> WITH CONSULT-II: Further inspection is necessary. Refer to [BL-55, "SYMPTOM CHART"](#).
- NG >> WITHOUT CONSULT-II: Replace keyfob. Refer to [BL-65, "ID Code Entry Procedure"](#).

## Remote Keyless Entry Receiver System Check

EIS006CJ

### 1. REMOTE KEYLESS ENTRY RECEIVER SIGNAL

Check signal voltage waveform between BCM connector M18 terminal 20 and ground using an oscilloscope.

**Condition:**

**Keyfob buttons released** : Refer to [BL-51, "Terminals and Reference Value for BCM"](#).

**Keyfob buttons pressed** : Refer to [BL-51, "Terminals and Reference Value for BCM"](#).

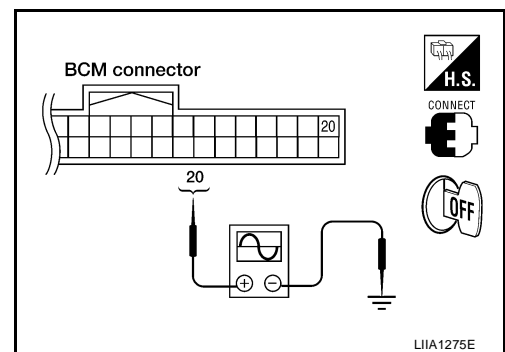

OK or NG

- OK >> Remote keyless entry receiver signal power supply, ground and signal circuits are OK. Replace BCM. Refer to [BCS-26, "Removal and Installation of BCM"](#).
- NG >> GO TO 2.

# REMOTE KEYLESS ENTRY SYSTEM

## 2. REMOTE KEYLESS ENTRY RECEIVER POWER SUPPLY INSPECTION

Check signal voltage waveform between BCM connector M18 terminal 19 and ground using an oscilloscope.

**19 - Ground**

**: Refer to [BL-51, "Terminals and Reference Value for BCM"](#) .**

OK or NG

OK >> GO TO 3.

NG >> Replace BCM. Refer to [BCS-26, "Removal and Installation of BCM"](#) .

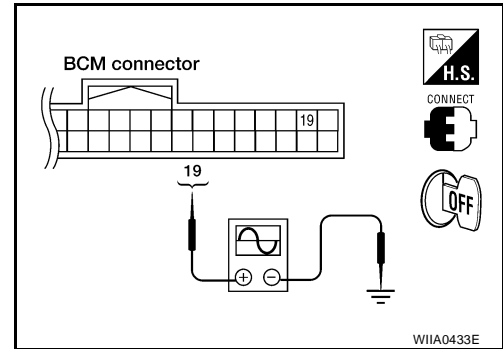

## 3. REMOTE KEYLESS ENTRY RECEIVER GROUND CIRCUIT INSPECTION (BCM)

Check continuity between BCM connector M18 terminal 18 and ground.

**18 - Ground**

**: Continuity should exist**

OK or NG

OK >> GO TO 4.

NG >> Replace BCM. Refer to [BCS-26, "Removal and Installation of BCM"](#) .

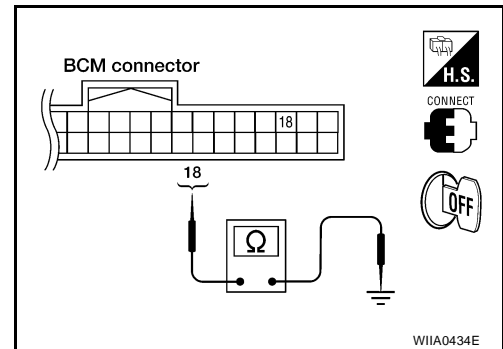

## 4. HARNESS INSPECTION BETWEEN BCM AND REMOTE KEYLESS ENTRY RECEIVER

1. Disconnect remote keyless entry receiver and BCM connectors.
2. Check continuity between remote keyless entry receiver connector M120 terminals 1, 2, 4 and BCM connector M18 terminals 18, 19, 20.

**1 - 18 : Continuity should exist**

**2 - 20 : Continuity should exist**

**4 - 19 : Continuity should exist**

3. Check continuity between remote keyless entry receiver terminals 1, 2 and 4 and ground.

**1 - Ground : Continuity should not exist**

**2 - Ground : Continuity should not exist**

**4 - Ground : Continuity should not exist**

OK or NG

OK >> Replace remote keyless entry receiver.

NG >> Repair or replace the harness between the remote keyless entry receiver and BCM.

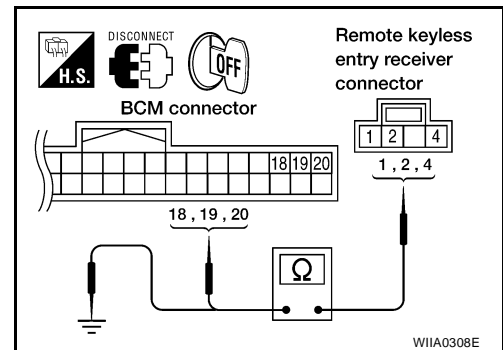

# REMOTE KEYLESS ENTRY SYSTEM

## ACC Power Check

EIS006CK

### 1. CHECK ACC POWER

 With CONSULT-II

Check "ACC ON SW" in DATA MONITOR mode with CONSULT-II. Refer to [BL-27, "DATA MONITOR"](#).

Monitor Item	Condition
ACC ON SW	Ignition switch position is ACC : ON
	Ignition switch position is OFF : OFF

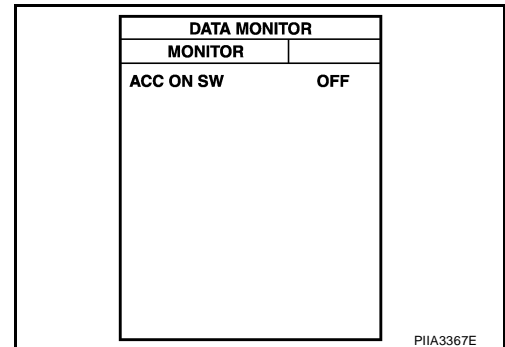

PIIA3367E

 Without CONSULT-II

Check voltage between BCM connector M18 terminal 11 and ground.

Connector	Terminal		Condition	Voltage (V) (Approx.)
	(+)	(-)		
M18	11	Ground	ACC	Battery voltage
			OFF	0

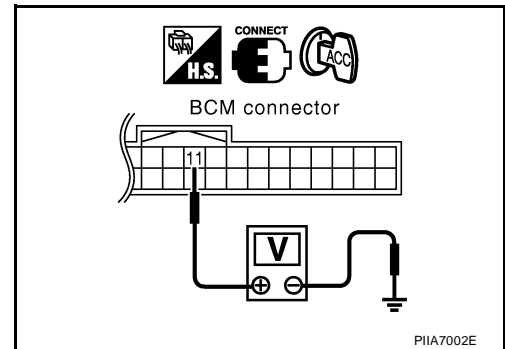

PIIA7002E

OK or NG

OK >> ACC power circuit is OK.

NG >> Check the following.

- 10A fuse [No. 4, located in fuse block (J/B)]
- Harness for open or short.

## IPDM E/R Operation Check

EIS006CL

### 1. CHECK IPDM E/R INPUT VOLTAGE

Check voltage between IPDM E/R connector E122 terminal 45 and ground.

Connector	Terminal		Voltage (V) (Approx.)
	(+)	(-)	
E122	45	Ground	Battery voltage

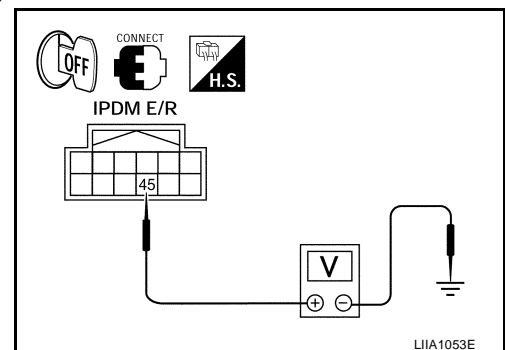

LIA1053E

OK or NG

OK >> Replace IPDM E/R. Refer to [PG-33, "Removal and Installation of IPDM E/R"](#).

NG >> GO TO 2.

# REMOTE KEYLESS ENTRY SYSTEM

## 2. CHECK IPDM E/R INPUT VOLTAGE CIRCUIT

1. Turn ignition switch OFF.
2. Disconnect IPDM E/R and horn relay.
3. Check continuity between IPDM E/R connector E122 terminal 45 and horn relay connector H-1 terminal 1.

**45 - 1 : Continuity should exist.**

4. Check continuity between IPDM E/R connector E122 terminal 45 and ground.

**45 - Ground : Continuity should not exist.**

OK or NG

OK >> Further inspection is necessary. Refer to [BL-55, "SYMP-TOM CHART"](#).

NG >> Repair or replace harness.

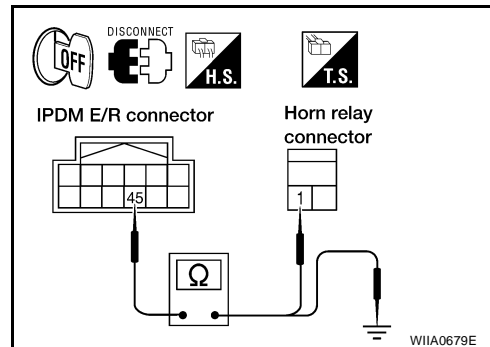

EIS006CM

## Check Hazard Function

### 1. CHECK HAZARD WARNING LAMP

Does hazard indicator flash with hazard switch?

Yes or No

Yes >> Hazard warning lamp circuit is OK.

No >> Check hazard indicator. Refer to [LT-49, "TURN SIGNAL AND HAZARD WARNING LAMPS"](#).

## Check Horn Function

EIS006CN

First, perform the "SELF-DIAG RESULTS" in "BCM" with CONSULT-II, then perform the trouble diagnosis of malfunction system indicated in "SELF-DIAG RESULTS" of "BCM".

### 1. CHECK HORN FUNCTION

Does horn sound with horn switch?

Yes or No

Yes >> Horn circuit is OK.

No >> Check horn circuit. Refer to [WW-50, "HORN"](#).

## Check Headlamp Function

EIS006CO

First, perform the "SELF-DIAG RESULTS" in "BCM" with CONSULT-II, then perform the trouble diagnosis of malfunction system indicated in "SELF-DIAG RESULTS" of "BCM".

### 1. CHECK HEADLAMP OPERATION

Does headlamp come on when turning lighting switch ON?

Yes or No

Yes >> Headlamp operation circuit is OK.

No >> Check headlamp circuit. Refer to [LT-5, "HEADLAMP \(FOR USA\)"](#).

## Check Room Lamp Illumination Function

EIS006CP

### 1. CHECK ROOM LAMP ILLUMINATION FUNCTION

When room lamp switch is in DOOR position, open the front door LH or RH.

**Room lamp and ignition keyhole illumination should illuminate.**

OK or NG

OK >> System is OK.

NG >> Check room lamp illumination circuit. Refer to [LT-105, "INTERIOR ROOM LAMP"](#).



# REMOTE KEYLESS ENTRY SYSTEM

EIS006CQ

## ID Code Entry Procedure KEYFOB ID SET UP WITH CONSULT-II

### NOTE:

- If a keyfob is lost, the ID code of the lost keyfob must be erased to prevent unauthorized use. A specific ID code can be erased with CONSULT-II. However, when the ID code of a lost keyfob is not known, all controller ID codes should be erased. After all ID codes are erased, the ID codes of all remaining and/or new keyfobs must be re-registered.
- When registering an additional keyfob, the existing ID codes in memory may or may not be erased. If five ID codes are stored in memory when an additional code is registered, only the oldest code is erased. If less than five codes are stored in memory when an additional code is registered, the new ID code is added and no ID codes are erased.
- Entry of a maximum of five ID codes is allowed. When more than five codes are entered, the oldest ID code will be erased.
- Even if the same ID code that is already in memory is input, the same ID code can be entered. The code is counted as an additional code.

### CAUTION:

If CONSULT-II is used with no connection of CONSULT-II CONVERTER, malfunctions might be detected in self-diagnosis depending on control unit which carries on CAN communication.

1. Turn ignition switch OFF.
2. Connect CONSULT-II and CONSULT-II CONVERTER to the data link connector.

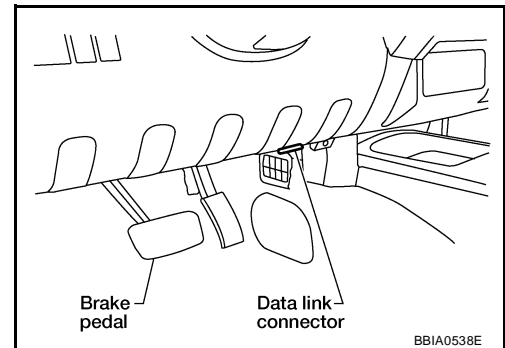

3. Turn ignition switch ON.
4. Touch "START (NISSAN BASED VHCL)".

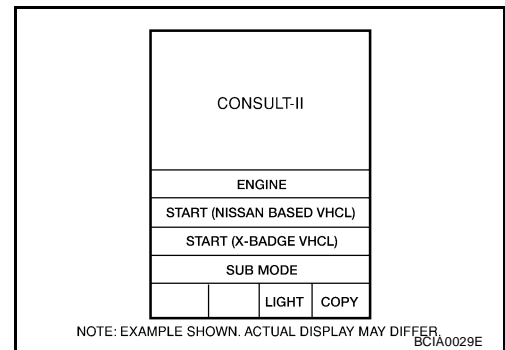

5. Touch "BCM".  
If "BCM" is not indicated, refer to [GI-41, "CONSULT-II Data Link Connector \(DLC\) Circuit"](#).

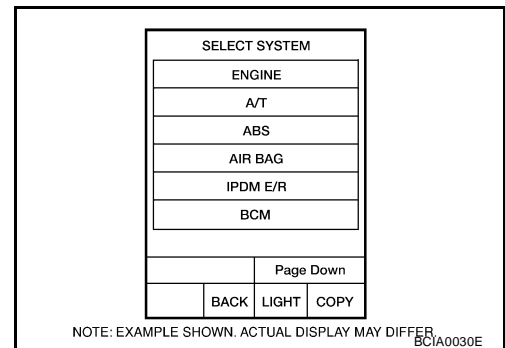

# REMOTE KEYLESS ENTRY SYSTEM

6. Touch "MULTI REMOTE ENT".

SELECT TEST ITEM
MULTI REMOTE ENT
HEAD LAMP
COMB SW
WIPER
BCM C/U
FLASHER

LIA0194E

7. Touch "WORK SUPPORT".

SELECT DIAG MODE		
WORK SUPPORT		
SELF-DIAG RESULTS		
CAN DIAG SUPPORT MNTR		
DATA MONITOR		
ACTIVE TEST		
ECU PART NUMBER		
	Page Down	
BACK	LIGHT	COPY

NOTE: EXAMPLE SHOWN. ACTUAL DISPLAY MAY DIFFER. BCIA0031E

8. The items shown on the figure can be set up.

- "REMO CONT ID REGIST"  
Use this mode to register a keyfob ID code.

**NOTE:**

**Register the ID code when keyfob or BCM is replaced, or when additional keyfob is required.**

- "REMO CONT ID ERASUR"  
Use this mode to erase a keyfob ID code.
- "REMO CONT ID CONFIR"  
Use this mode to confirm if a keyfob ID code is registered or not.

SELECT WORK ITEM
REMO CONT ID REGIST
REMO CONT ID ERASUR
REMO CONT ID CONFIR
HORN CHIRP SET
HAZARD LAMP SET
MULTI ANSWER BACK SET

LIA1147E

# REMOTE KEYLESS ENTRY SYSTEM

## KEYFOB ID SET UP WITHOUT CONSULT-II

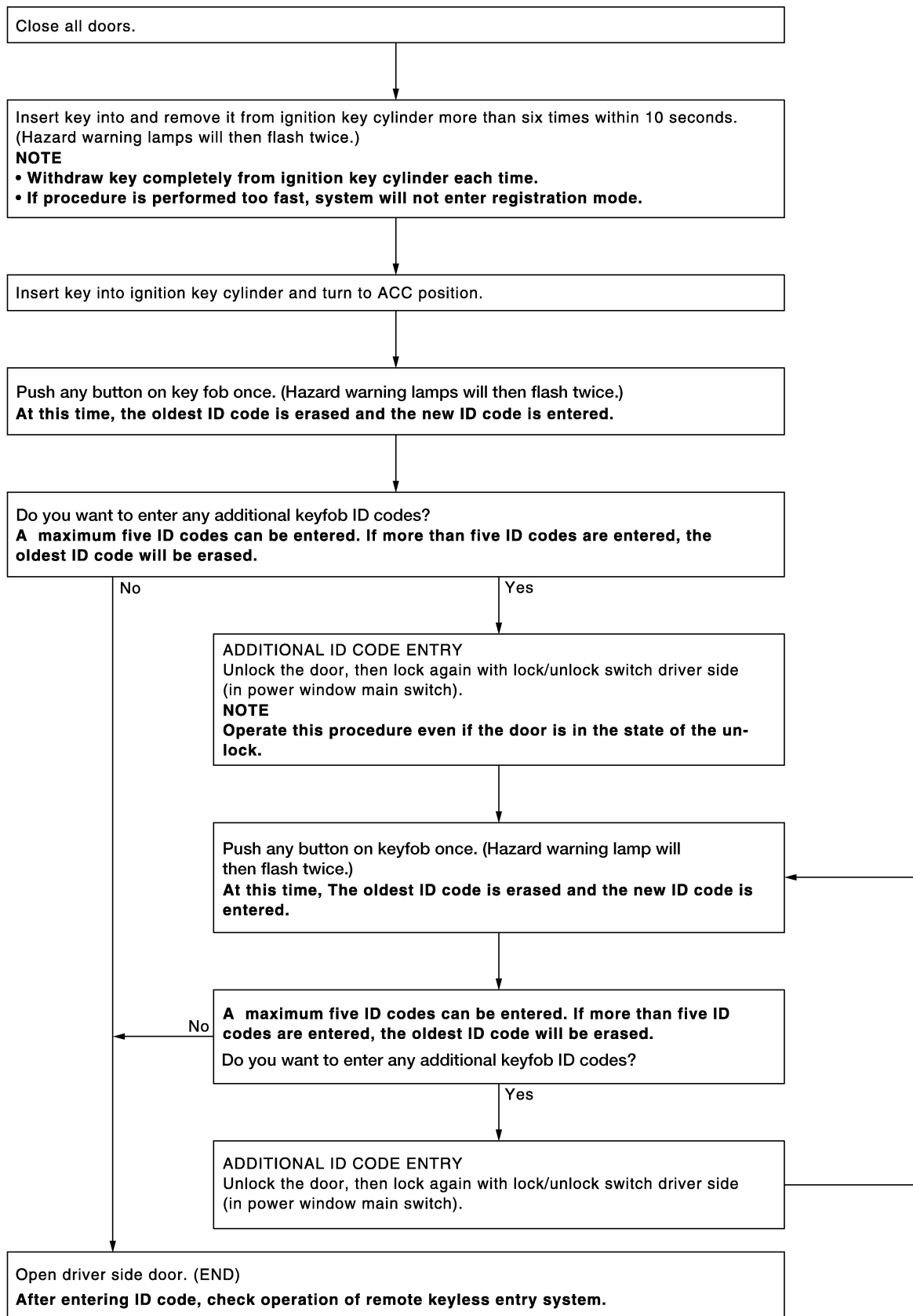

A  
B  
C  
D  
E  
F  
G  
H  
BL  
J  
K  
L  
M

LIIA1670E

# REMOTE KEYLESS ENTRY SYSTEM

## NOTE:

- If a keyfob is lost, the ID code of the lost keyfob must be erased to prevent unauthorized use. A specific ID code can be erased with CONSULT-II. However, when the ID code of a lost keyfob is not known, all controller ID codes should be erased. After all ID codes are erased, the ID codes of all remaining and/or new keyfobs must be re-registered.  
To erase all ID codes in memory, register one ID code (keyfob) five times. After all ID codes are erased, the ID codes of all remaining and/or new keyfobs must be re-registered.
- When registering an additional keyfob, the existing ID codes in memory may or may not be erased. If five ID codes are stored in memory, when an additional code is registered, only the oldest code is erased. If less than five ID codes are stored in memory, when an additional ID code is registered, the new ID code is added and no ID codes are erased.
- If you need to activate more than two additional new keyfobs, repeat the procedure “Additional ID code entry” for each new keyfob.
- Entry of maximum five ID codes is allowed. When more than five ID codes are entered, the oldest ID code will be erased.
- Even if same ID code that is already in the memory is input, the same ID code can be entered. The code is counted as an additional code.

## Keyfob Battery Replacement

EIS006CR

### NOTE:

- Be careful not to touch the circuit board or battery terminal.
  - The keyfob is water-resistant. However, if it does get wet, immediately wipe it dry.
1. Open the lid using a coin.
  2. Remove the battery.
  3. Install the new battery, positive side down.
  4. Close the lid securely. Push the keyfob buttons two or three times to check operation.

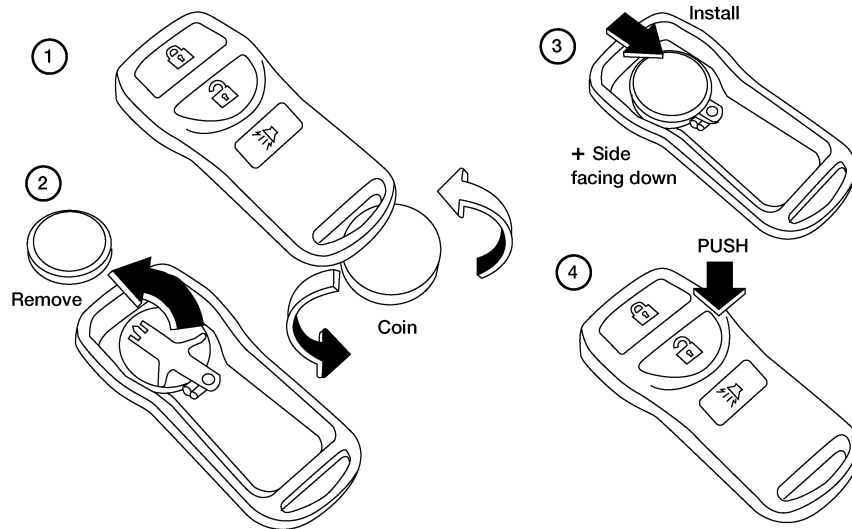

LIA1514E

# VEHICLE SECURITY (THEFT WARNING) SYSTEM

## VEHICLE SECURITY (THEFT WARNING) SYSTEM

PFP:28491

### Component Parts and Harness Connector Location

EIS006CS

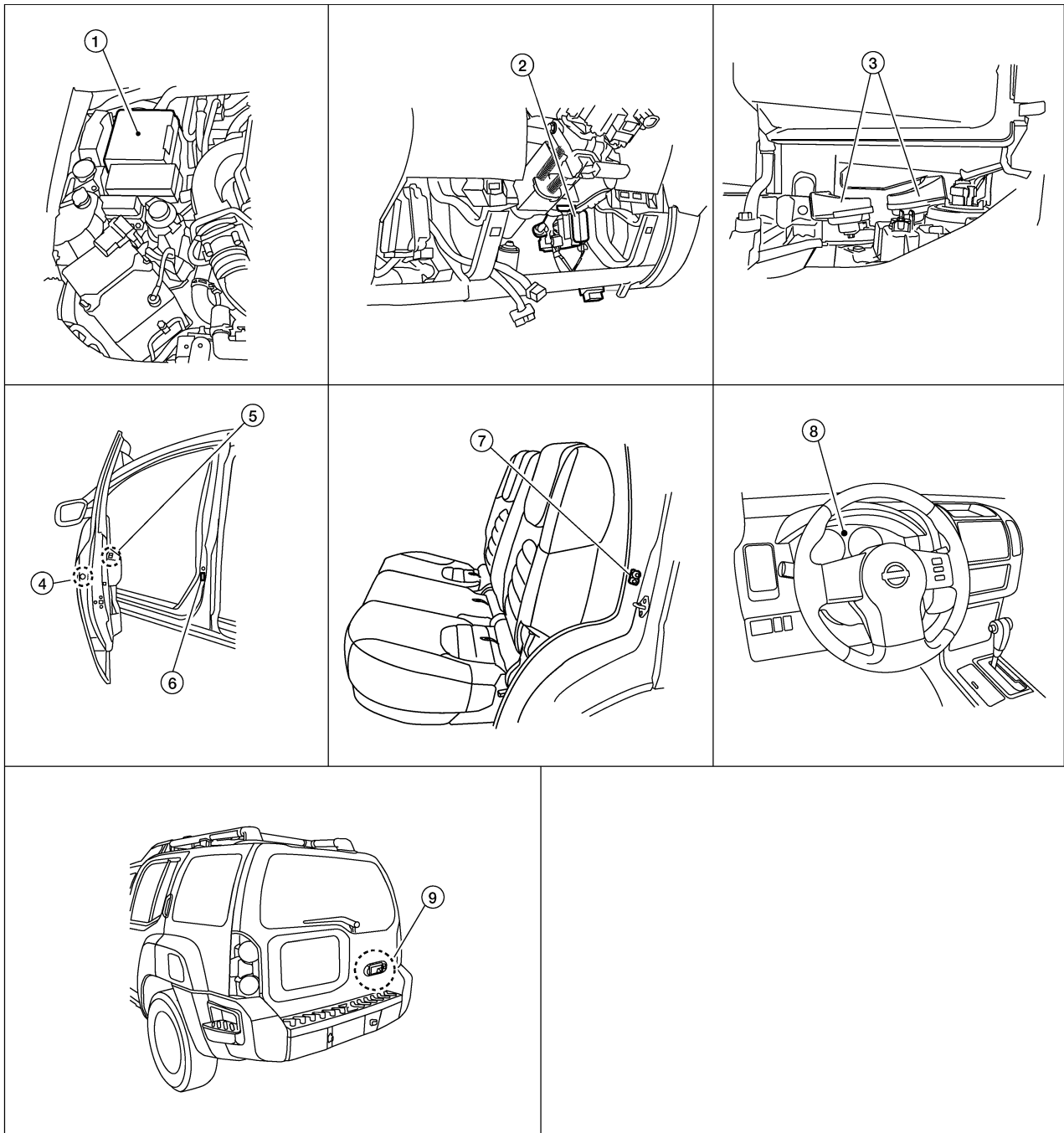

- |  |   |  |
|--|---|--|
| 1. IPDM E/R E122, E123, E124                             | 2. BCM M18, M19, M20<br>(view with instrument lower panel LH removed)                                   | 3. Horns E3, E162<br>(Behind front combination lamp LH)        |
| 4. Front door lock assembly LH (key cylinder switch) D14 | 5. Main power window and door lock/unlock switch D7<br>Power window and door lock/unlock switch RH D105 | 6. Front door switch<br>LH B8<br>RH B108                       |
| 7. Rear door switch<br>LH B18<br>RH B116                 | 8. Combination meter M24  | 9. Back door switch D502<br>Back door key cylinder switch D505 |

LIA2427E

A  
B  
C  
D  
E  
F  
G  
H  
BL  
J  
K  
L  
M

# VEHICLE SECURITY (THEFT WARNING) SYSTEM

EIS006CT

## System Description

### DESCRIPTION

### Operation Flow

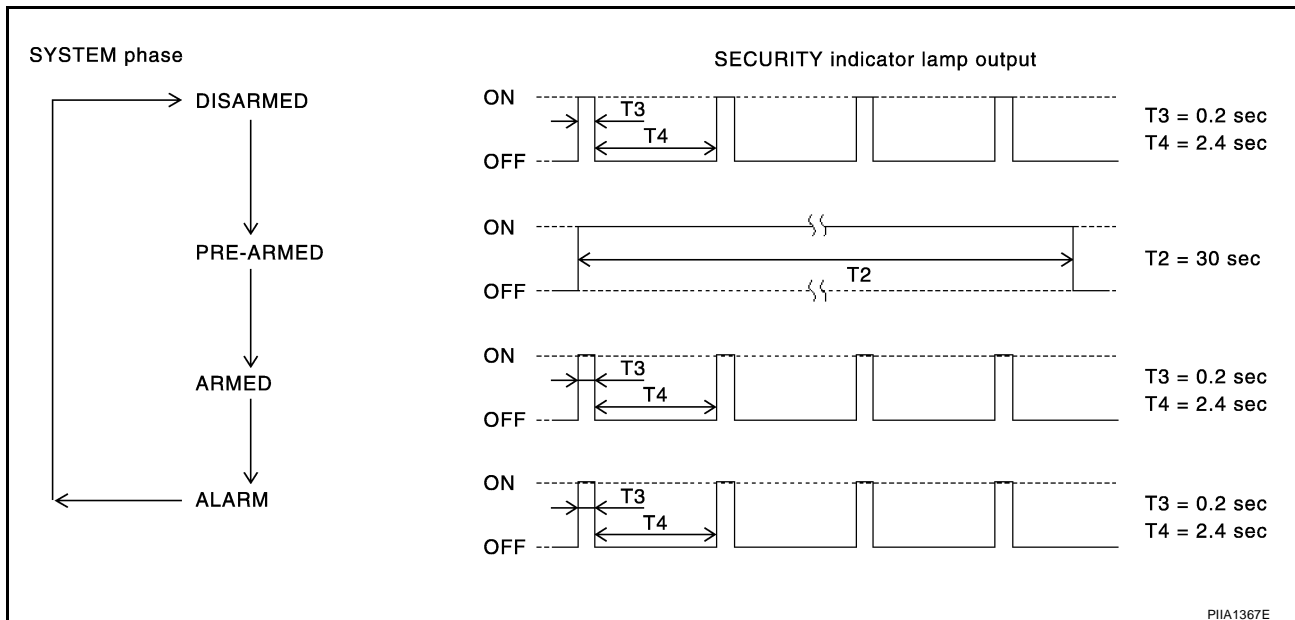

## Setting the vehicle security system

### Initial condition

- Ignition switch is in OFF position.

### Disarmed phase

- When the vehicle is being driven or when doors are open, the vehicle security system is set in the disarmed phase on the assumption that the owner is inside or near the vehicle.

### Pre-armed phase and armed phase

- The vehicle security system turns into the "pre-armed" phase when all doors are closed and locked. The security indicator lamp illuminates for 30 seconds. Then, the system automatically shifts into the "armed" phase.

## Canceling the set vehicle security system

When one of the following operations is performed, the armed phase is canceled.

1. Unlock the doors with the key.
2. Unlock the doors with the keyfob.

## Activating the alarm operation of the vehicle security system

Make sure the system is in the armed phase.

When one of the following operations is performed, the system sounds the horns and flashes the headlamps for about 50 seconds.

1. Any door is opened before unlocking door with key or keyfob.
2. Door is unlocked without using key or keyfob.

## POWER SUPPLY AND GROUND CIRCUIT

Power is supplied at all times

- through 10A fuse [No.19, located in the fuse block (J/B)]
- to combination meter (security indicator lamp) terminal 3 and
- through 50A fusible link (letter **g**, located in the fuse and fusible link box)
- to BCM (body control module) terminal 70
- through 10A fuse [No. 18, located in the fuse block (J/B)]
- to BCM terminal 57
- through 15A fuse (No. 30, located in the fuse and fusible link box)

# VEHICLE SECURITY (THEFT WARNING) SYSTEM

- to horn relay terminal 2
- through 20A fuse (No. 52, located in the IPDM E/R) and
- through 20A fuse (No. 53, located in the IPDM E/R),
- to IPDM E/R internal CPU.

With the ignition switch in the ACC or ON position, power is supplied

- through 10A fuse [No. 4, located in the fuse block (J/B)]
- to BCM terminal 11.

Ground is supplied

- to BCM terminal 67
- through body grounds M57, M61 and M79 and
- to IPDM E/R terminals 38 and 59
- through body ground E9, E15 and E24.

## INITIAL CONDITION TO ACTIVATE THE SYSTEM

The operation of the vehicle security system is controlled by the doors.

To activate the vehicle security system, BCM must receive signals indicating the doors are closed and locked.

When a door is open, BCM terminal 12, 13, 43, 47 or 48 receives a ground signal from each door switch.

When front door LH or RH is unlocked, BCM terminal 46 receives a signal from terminal 11 of main power window and door lock/unlock switch or terminal 2 of power window and door lock/unlock switch RH.

When the back door is open, BCM terminal 43 receives a ground signal

- from terminal 3 of the back door switch
- through terminal 1 of the back door switch
- through body grounds D406 and D652.

## VEHICLE SECURITY SYSTEM ALARM OPERATION

The vehicle security system is triggered by

- opening a door
- unlocking door without using the key or keyfob.

The vehicle security system will be triggered once the system is in armed phase,

- when BCM receives a ground signal at terminals 12, 13, 47, 48 (door switch) or terminal 43 (back door switch).

When the vehicle security system is triggered, ground is supplied intermittently

- from IPDM E/R CPU
- to headlamp high relay and
- from IPDM E/R terminal 45
- to horn relay terminal 1.

The headlamps flash and the horn sounds intermittently.

The alarm automatically turns off after 50 seconds, but will reactivate if the vehicle is tampered with again.

## VEHICLE SECURITY SYSTEM DEACTIVATION

To deactivate the vehicle security system, a door must be unlocked with the key or keyfob.

When the key is used to unlock a door, BCM terminal 7 receives signal

- from terminal 3 of front door lock assembly LH (key cylinder switch) or back door key cylinder switch.

When the BCM receives either one of these signals or unlock signal from keyfob or key cylinder switch, the vehicle security system is deactivated. (Disarmed phase)

## PANIC ALARM OPERATION

Remote keyless entry system can operate vehicle security system (horn and headlamps) as required.

When the remote keyless entry system is triggered, ground is supplied intermittently

- from IPDM E/R CPU
- to headlamp high relay and
- from IPDM E/R terminal 45
- to horn relay terminal 1.

The headlamp flashes and the horn sounds intermittently.

A

B

C

D

E

F

G

H

BL

J

K

L

M

# VEHICLE SECURITY (THEFT WARNING) SYSTEM

---

The alarm automatically turns off after 25 seconds or when BCM receives any signal from keyfob.

## **CAN Communication System Description**

EIS006CU

Refer to [LAN-21, "CAN COMMUNICATION"](#) .



# VEHICLE SECURITY (THEFT WARNING) SYSTEM

## Schematic

EIS006CV

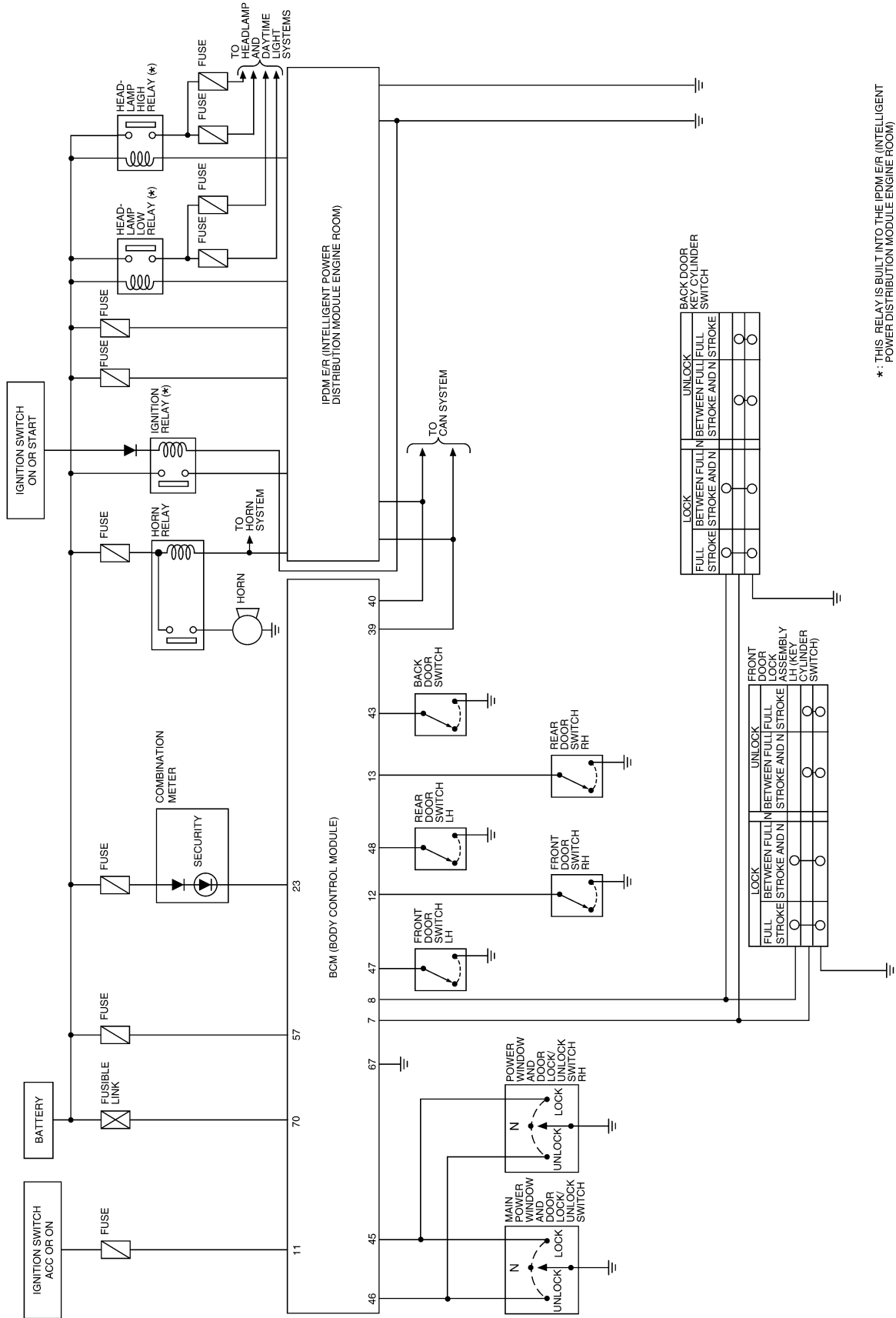

\*: THIS RELAY IS BUILT INTO THE IPDM E/R (INTELLIGENT POWER DISTRIBUTION MODULE ENGINE ROOM)

WIWA1693E

A  
B  
C  
D  
E  
F  
G  
H  
I  
J  
K  
L  
M

BL

# VEHICLE SECURITY (THEFT WARNING) SYSTEM

EIS006CW

## Wiring Diagram — VEHSEC —

BL-VEHSEC-01

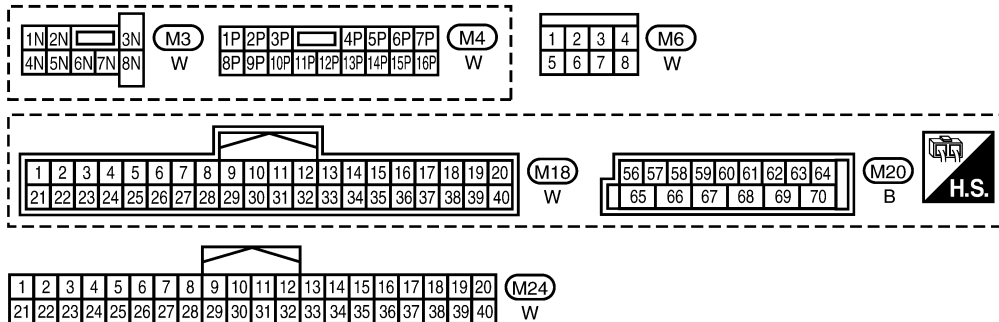
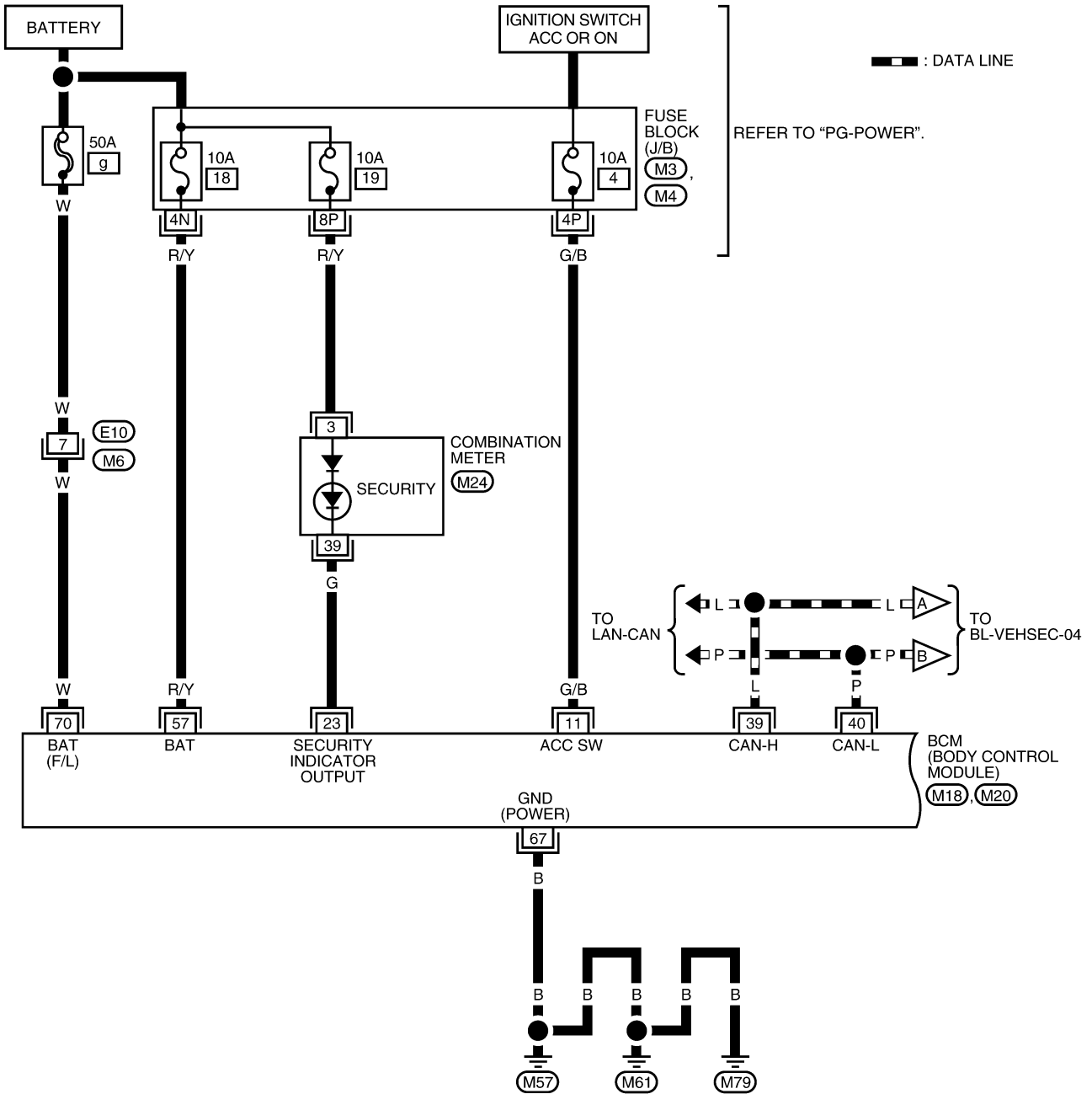

WIWA1694E

# VEHICLE SECURITY (THEFT WARNING) SYSTEM

BL-VEHSEC-02

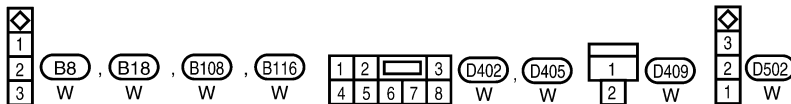
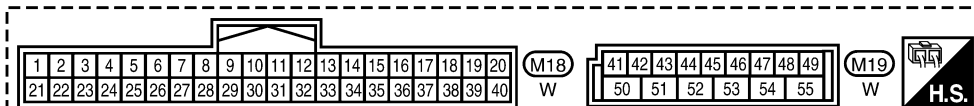
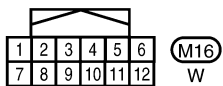
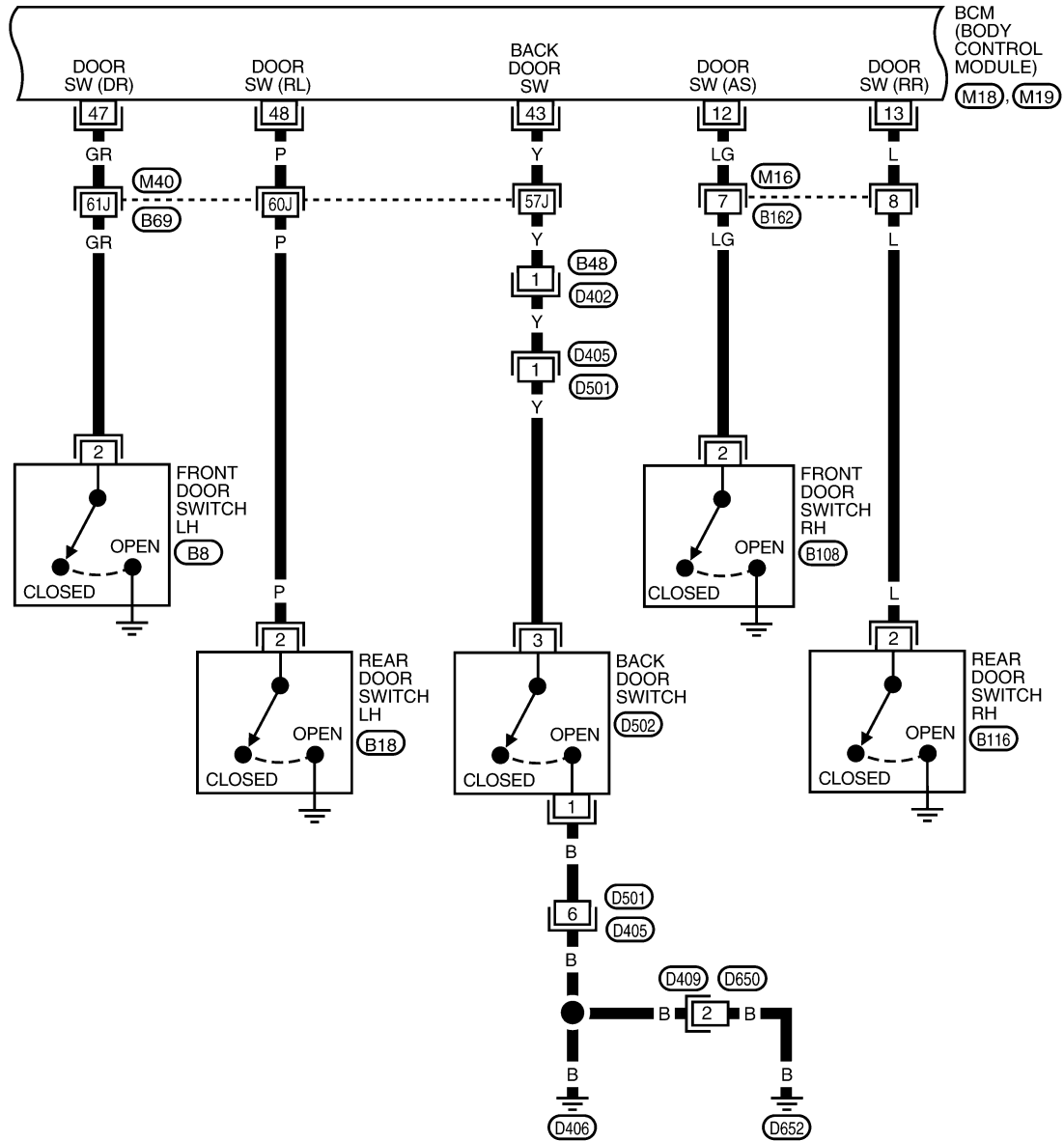

REFER TO THE FOLLOWING.  
**M40** - SUPER MULTIPLE JUNCTION (SMJ)

W1WA0824E

# VEHICLE SECURITY (THEFT WARNING) SYSTEM

BL-VEHSEC-03

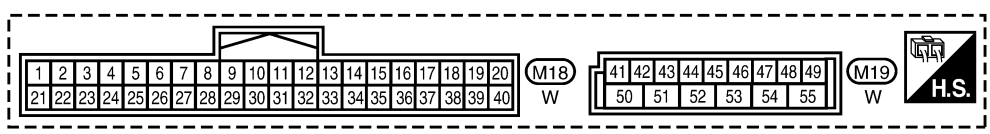
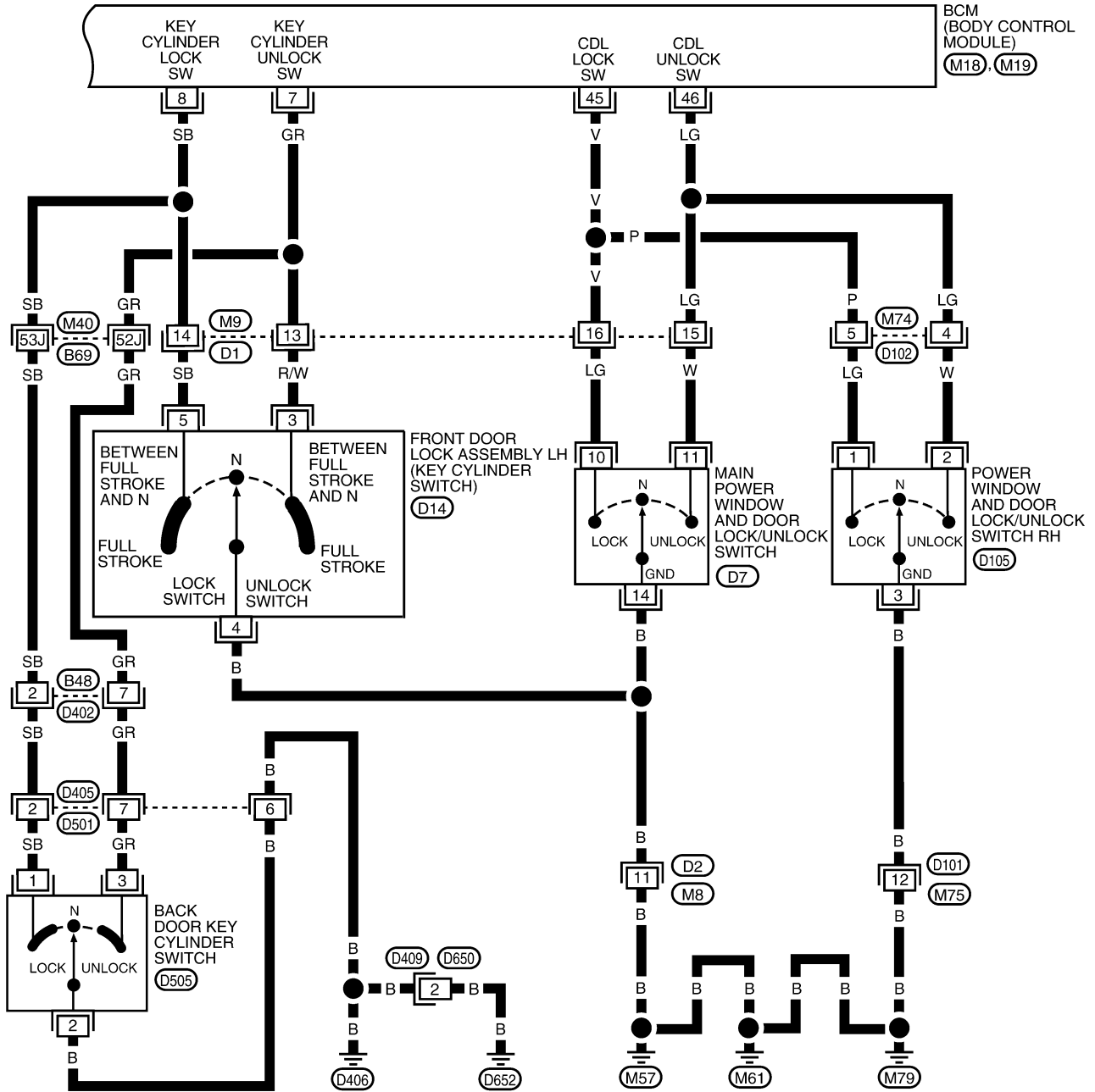

REFER TO THE FOLLOWING.  
 (M40) - SUPER MULTIPLE JUNCTION (SMJ)

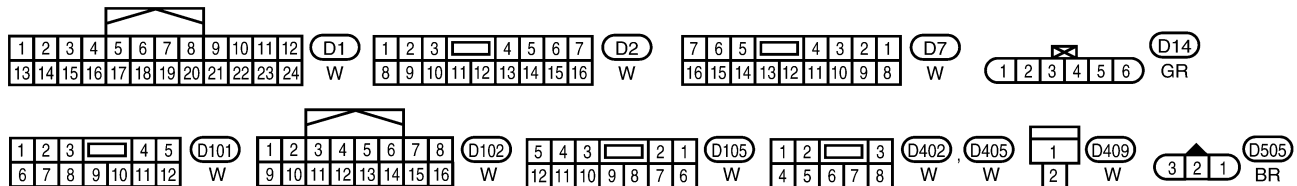

WIWA0825E

# VEHICLE SECURITY (THEFT WARNING) SYSTEM

BL-VEHSEC-04

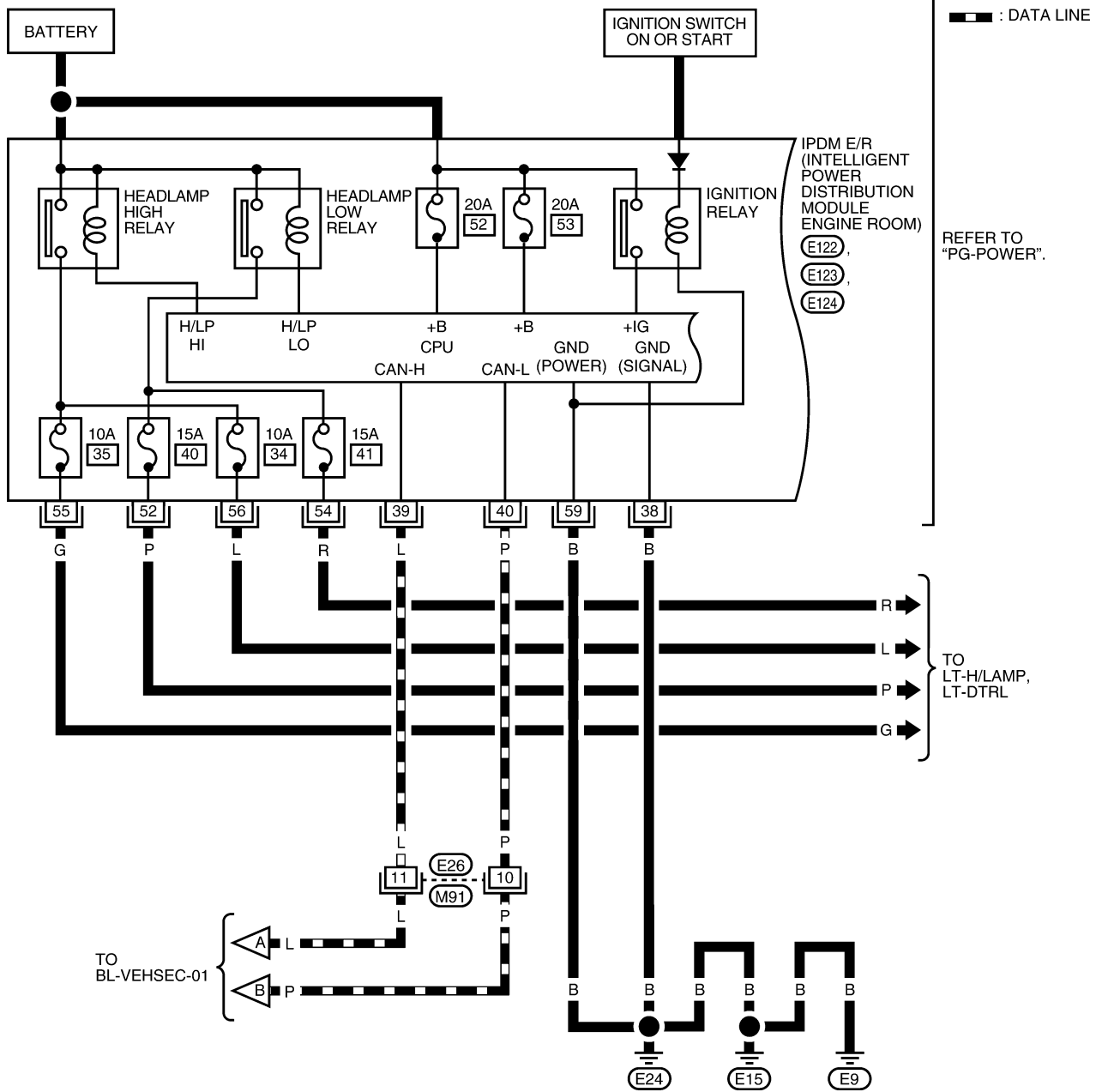

1	2	3	4	5	6	7	(M91)		
8	9	10	11	12	13	14	15	16	W

37	38	39	40	41	42	(E122)	49	50	51	(E123)	57	58	59	(E124)		
43	44	45	46	47	48	W	52	53	54	55	56	BR	60	61	62	B

WIWA1695E

# VEHICLE SECURITY (THEFT WARNING) SYSTEM

## BL-VEHSEC-05

⬡DN⬡ : WITH DUAL NOTE HORN

⬡SN⬡ : WITH SINGLE NOTE HORN

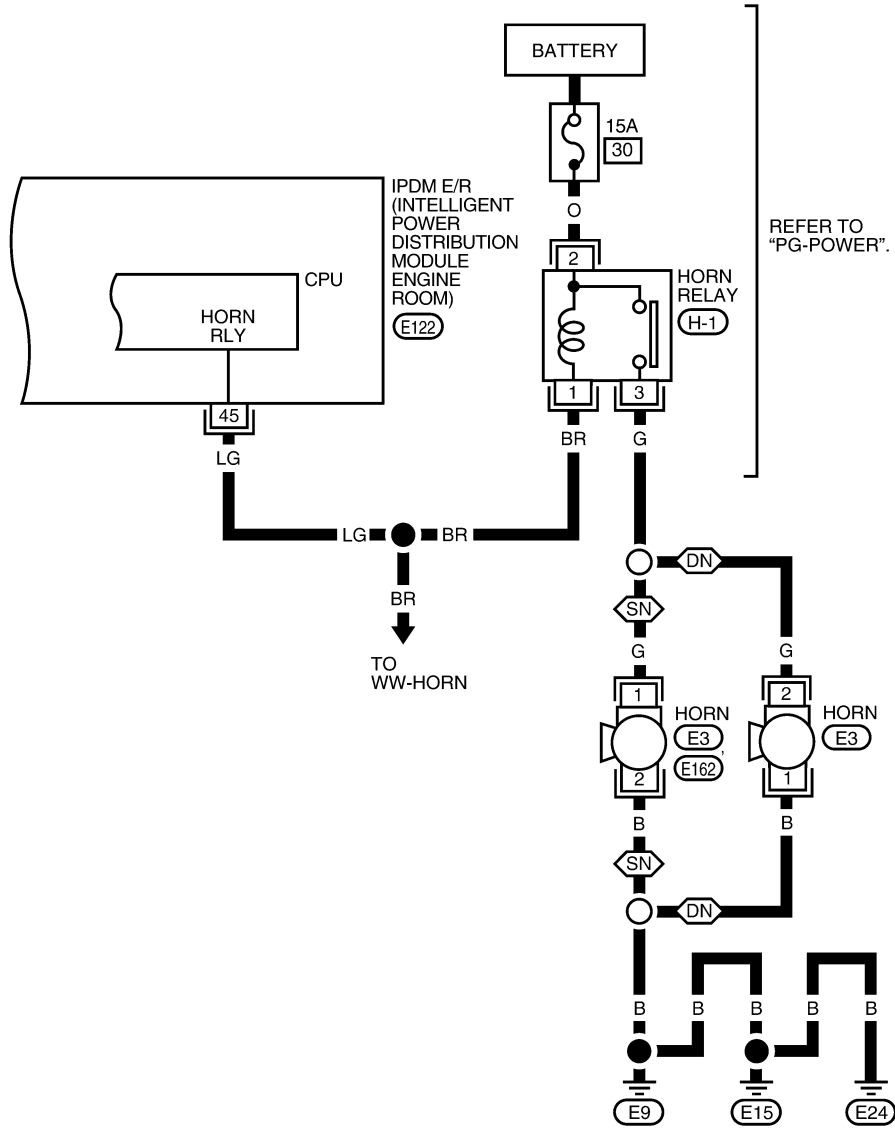

REFER TO  
"PG-POWER".

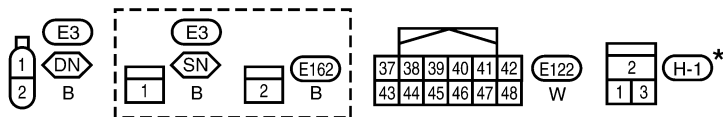

\* : THIS CONNECTOR IS NOT SHOWN IN "HARNESS LAYOUT" OF PG SECTION.

WIWA1696E

# VEHICLE SECURITY (THEFT WARNING) SYSTEM

## Terminals and Reference Value for BCM

EIS006CX

Refer to [BCS-12, "Terminals and Reference Values for BCM"](#).

## Terminals and Reference Value for IPDM E/R

EIS006CY

Refer to [PG-29, "Terminals and Reference Values for IPDM E/R"](#).

## CONSULT-II Function (BCM)

EIS006CZ

CONSULT-II can display each diagnostic item using the diagnostic test modes shown following.

BCM diagnostic test item	Diagnostic mode	Description
Inspection by part	WORK SUPPORT	Supports inspections and adjustments. Commands are transmitted to the BCM for setting the status suitable for required operation, input/output signals are received from the BCM and received data is displayed.
	DATA MONITOR	Displays BCM input/output data in real time.
	ACTIVE TEST	Operation of electrical loads can be checked by sending drive signal to them.
	SELF-DIAG RESULTS	Displays BCM self-diagnosis results.
	CAN DIAG SUPPORT MNTR	The result of transmit/receive diagnosis of CAN communication can be read.
	ECU PART NUMBER	BCM part number can be read.
	CONFIGURATION	Performs BCM configuration read/write functions.

## CONSULT-II INSPECTION PROCEDURE

### CAUTION:

If CONSULT-II is used with no connection of CONSULT-II CONVERTER, malfunctions might be detected in self-diagnosis depending on control unit which carries out CAN communication.

1. Turn ignition switch OFF.
2. Connect CONSULT-II and CONSULT-II CONVERTER to the data link connector.

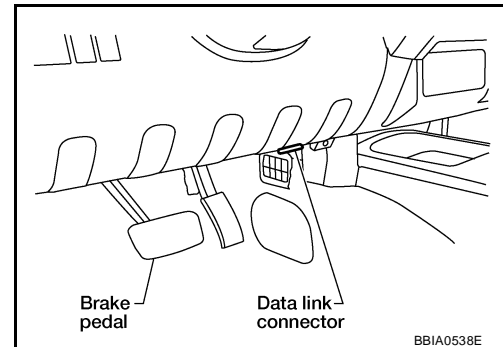

3. Turn ignition switch ON.
4. Touch "START (NISSAN BASED VHCL)".

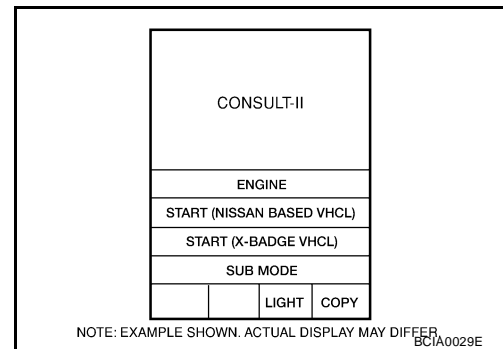

# VEHICLE SECURITY (THEFT WARNING) SYSTEM

5. Touch "BCM".  
If "BCM" is not indicated, refer to [GI-41, "CONSULT-II Data Link Connector \(DLC\) Circuit"](#).

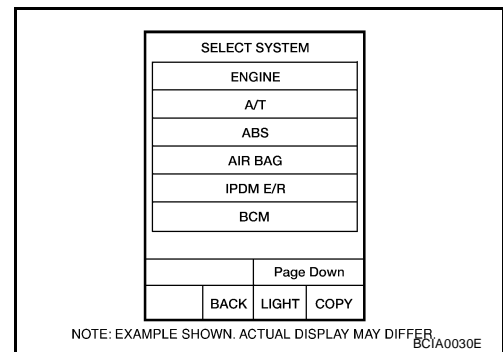

6. Touch "THEFT ALM" on the "SELECT TEST ITEM" screen.

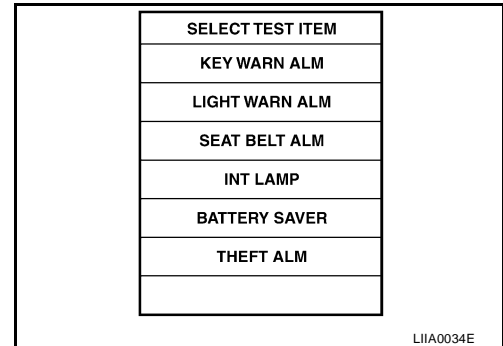

7. Select diagnosis mode.  
"DATA MONITOR", "ACTIVE TEST" and "WORK SUPPORT" are available.

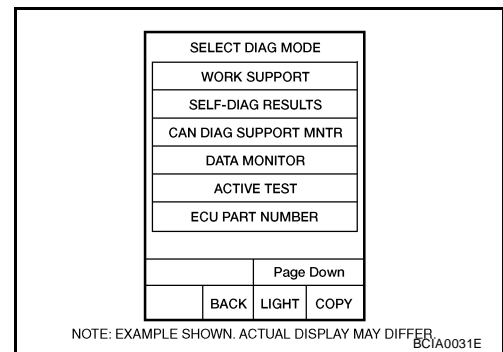

## CONSULT-II APPLICATION ITEM

### Data Monitor

Monitored Item	Description
DOOR SW-AS	Indicates [ON/OFF] condition of front door switch RH.
DOOR SW-RR	Indicates [ON/OFF] condition of rear door switch RH.
DOOR SW-RL	Indicates [ON/OFF] condition of rear door switch LH.
DOOR SW-DR	Indicates [ON/OFF] condition of front door switch LH.
BACK DOOR SW	Indicates [ON/OFF] condition of back door switch.
ACC ON SW	Indicates [ON/OFF] condition of ignition switch in ACC position.
IGN ON SW	Indicates [ON/OFF] condition of ignition switch in ON position.
KEYLESS UNLOCK	Indicates [ON/OFF] condition of unlock signal from keyfob.
KEYLESS LOCK	Indicates [ON/OFF] condition of lock signal from keyfob.
KEY CYL LK-SW	Indicates [ON/OFF] condition of lock signal from door key cylinder switch.
KEY CYL UN-SW	Indicates [ON/OFF] condition of unlock signal from door key cylinder switch.
CDL UNLOCK SW	Indicates [ON/OFF] condition of unlock signal from lock/unlock switch.
CDL LOCK SW	Indicates [ON/OFF] condition of lock signal from lock/unlock switch.



# VEHICLE SECURITY (THEFT WARNING) SYSTEM

## Active Test

Test Item	Description
THEFT IND	This test is able to check security indicator lamp operation. The lamp will be turned on when "ON" on CONSULT-II screen is touched.
HEAD LAMP (HI)	This test is able to check vehicle security lamp operation. The high beam headlamps will be activated for 0.5 seconds after "ON" on CONSULT-II screen is touched.
VEHICLE SECURITY HORN	This test is able to check vehicle security horn operation. The horns will be activated for 0.5 seconds after "ON" on CONSULT-II screen is touched.

## Work Support

Test Item	Description
SECURITY ALARM SET	This mode can confirm and change vehicle security alarm ON-OFF setting.
THEFT ALM TRG	The switch which triggered vehicle security alarm is recorded. This mode is able to confirm and erase the record of vehicle security alarm. The trigger data can be erased by touching "CLEAR" on CONSULT-II screen.

## Trouble Diagnosis WORK FLOW

EIS006D0

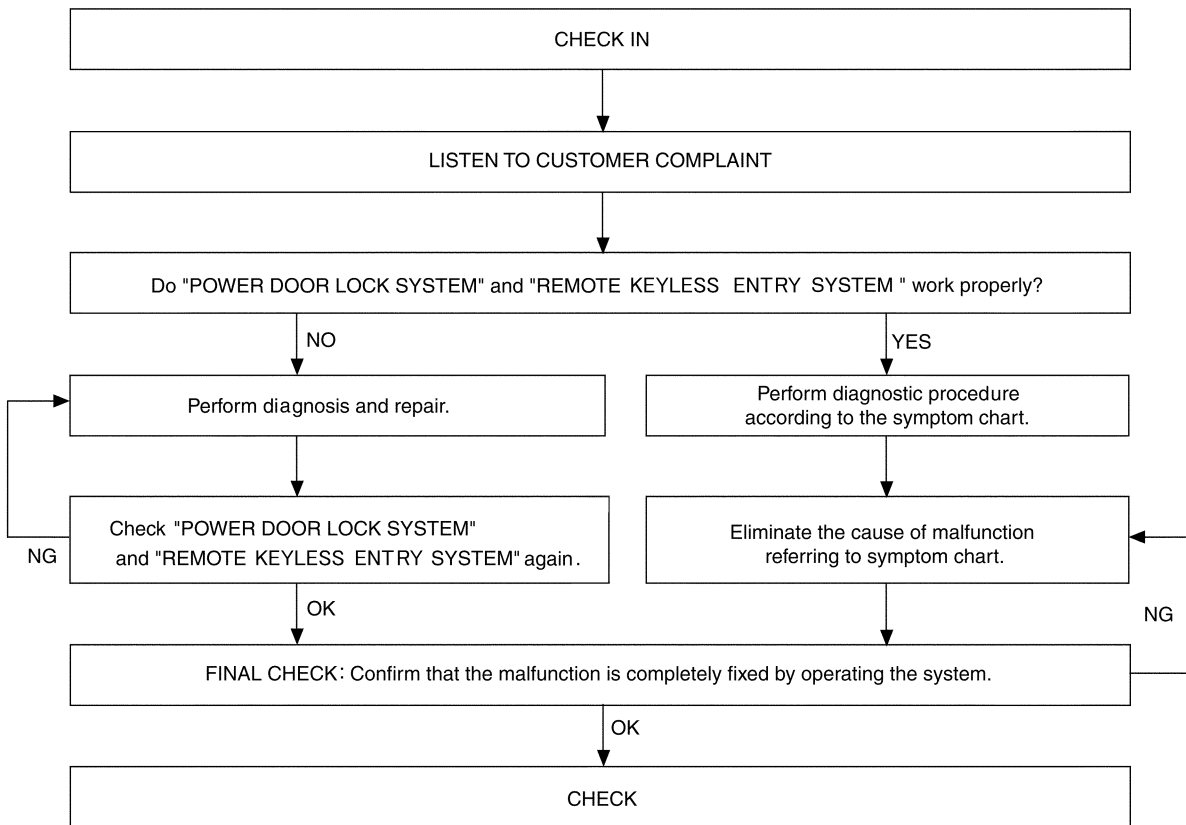

WIIA0599E

- "POWER DOOR LOCK SYSTEM" diagnosis refer to [BL-16, "POWER DOOR LOCK SYSTEM"](#) .
- "REMOTE KEYLESS ENTRY SYSTEM" diagnosis refer to [BL-43, "REMOTE KEYLESS ENTRY SYSTEM"](#) .

# VEHICLE SECURITY (THEFT WARNING) SYSTEM

EIS006D1

## Preliminary Check

The system operation is canceled by turning ignition switch to ACC at any step between START and ARMED in the following flow chart.

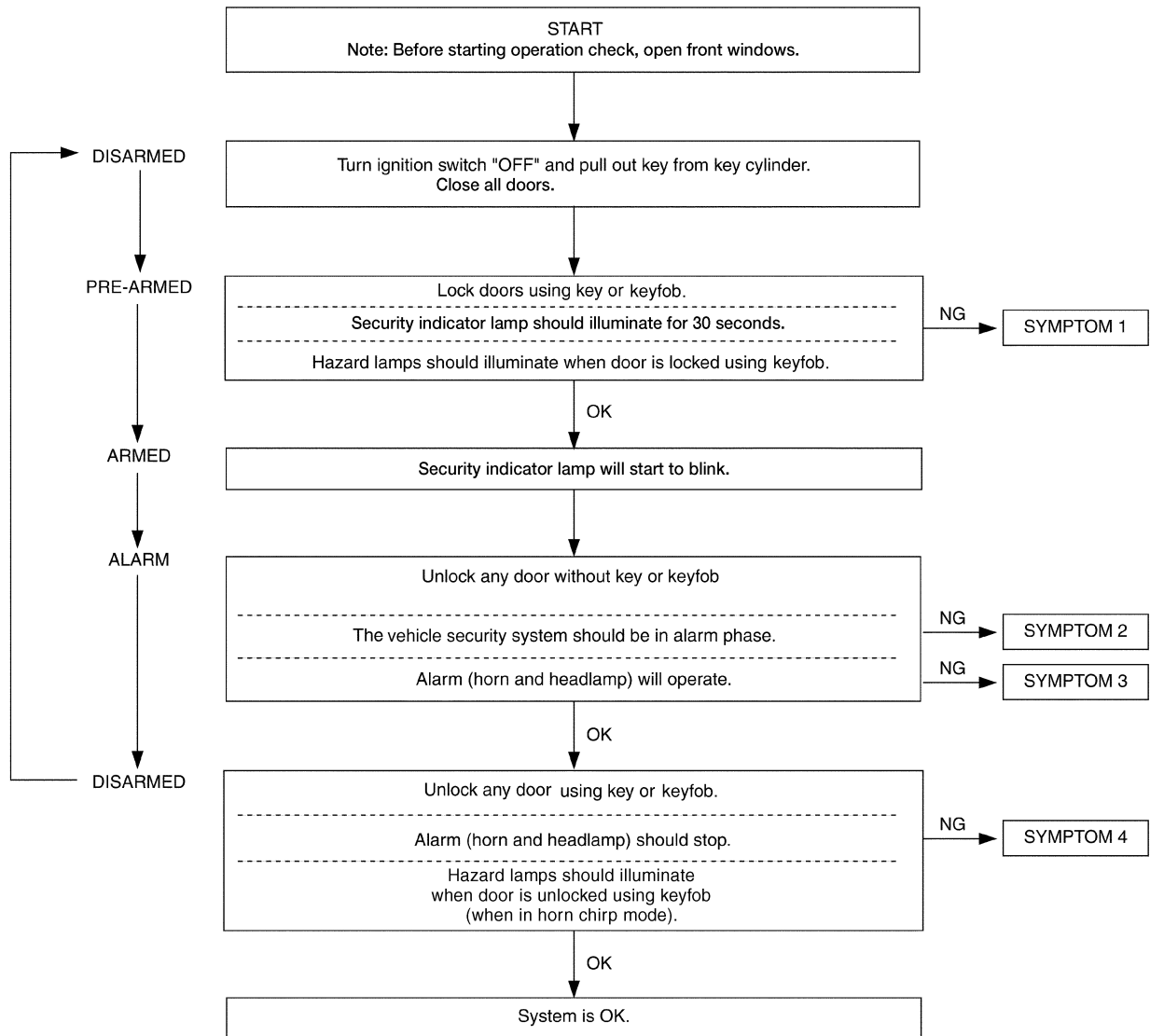

WIIA0627E

After performing preliminary check, go to Symptom Chart.

# VEHICLE SECURITY (THEFT WARNING) SYSTEM

## Symptom Chart

EIS006D2

PROCEDURE		Diagnostic procedure
SYMPTOM		
1	Vehicle security system cannot be set by ....	All items Diagnostic Procedure 1 Refer to <a href="#">BL-84, "Diagnostic Procedure 1"</a> . If the above systems are "OK", replace BCM. Refer to <a href="#">BCS-26, "Removal and Installation of BCM"</a> .
		Lock/unlock switch Diagnostic Procedure 6 Refer to <a href="#">BL-91, "Diagnostic Procedure 6"</a> . If the above systems are "OK", check main power window and door lock/unlock switch.
	Door outside key	Diagnostic Procedure 3 Refer to <a href="#">BL-88, "Diagnostic Procedure 3"</a> . If the above systems are "OK", check main power window and door lock/unlock switch.
		Security indicator does not turn "ON". Diagnostic Procedure 2 Refer to <a href="#">BL-87, "Diagnostic Procedure 2"</a> . If the above systems are "OK", replace BCM. Refer to <a href="#">BCS-26, "Removal and Installation of BCM"</a> .
	*1 Vehicle security system does not alarm when ....	Any door or glass hatch is opened. Diagnostic Procedure 1 Refer to <a href="#">BL-84, "Diagnostic Procedure 1"</a> . If the above systems are "OK", replace BCM. Refer to <a href="#">BCS-26, "Removal and Installation of BCM"</a> .
		Vehicle security alarm does not activate.
Headlamp alarm Diagnostic Procedure 5 Refer to <a href="#">BL-91, "Diagnostic Procedure 5"</a> . If the above systems are "OK", replace BCM. Refer to <a href="#">BCS-26, "Removal and Installation of BCM"</a> .		
4	Vehicle security system cannot be canceled by ....	Door outside key Diagnostic Procedure 3 Refer to <a href="#">BL-88, "Diagnostic Procedure 3"</a> . If the above systems are "OK", check main power window and door lock/unlock switch.
		Keyfob Check remote keyless entry function. If the above systems are "OK", replace BCM. Refer to <a href="#">BCS-26, "Removal and Installation of BCM"</a> .

\*1: Make sure the system is in the armed phase.

# VEHICLE SECURITY (THEFT WARNING) SYSTEM

EIS006D3

## Diagnostic Procedure 1

### DOOR SWITCH CHECK

#### 1. CHECK DOOR SWITCHES INPUT SIGNAL

 With CONSULT-II

Check door switches ("DOOR SW-DR", "DOOR SW-AS", "DOOR SW-RL", "DOOR SW-RR", "BACK DOOR SW") in DATA MONITOR mode with CONSULT-II. Refer to [BL-80, "Data Monitor"](#).

- When doors are open:

**DOOR SW-DR : ON**  
**DOOR SW-AS : ON**  
**DOOR SW-RL : ON**  
**DOOR SW-RR : ON**  
**BACK DOOR SW : ON**

- When doors are closed:

**DOOR SW-DR : OFF**  
**DOOR SW-AS : OFF**  
**DOOR SW-RL : OFF**  
**DOOR SW-RR : OFF**  
**BACK DOOR SW : OFF**

DATA MONITOR	
MONITOR	
DOOR SW - DR	OFF
DOOR SW - AS	OFF
DOOR SW - RR	OFF
DOOR SW - RL	OFF
BACK DOOR SW	OFF

LIA0665E

 Without CONSULT-II

Check voltage between BCM connector M18 or M19 terminals 12, 13, 43, 47, 48 and ground.

Connector	Item	Terminals		Condition	Voltage (V) (Approx.)
		(+)	(-)		
M19	Back door switch	43	Ground	Open ↓ Closed	0 ↓ Battery voltage
	Front door switch LH	47			
	Rear door switch LH	48			
M18	Front door switch RH	12	Ground	Open ↓ Closed	0 ↓ Battery voltage
	Rear door switch RH	13			

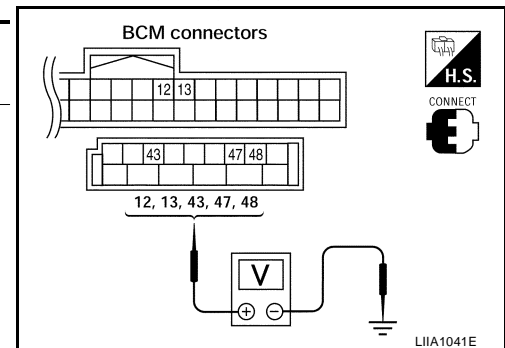

**OK or NG**

- OK >> Door switch circuit is OK.  
 NG >> GO TO 2.

# VEHICLE SECURITY (THEFT WARNING) SYSTEM

## 2. CHECK BCM OUTPUT VOLTAGE

1. Turn ignition switch OFF.
2. Disconnect door switches.
3. Check voltage between BCM connector M18, M19 terminals 12, 13, 43, 47, 48 and ground.

**12 - Ground : Battery voltage**  
**13 - Ground : Battery voltage**  
**43 - Ground : Battery voltage**  
**47 - Ground : Battery voltage**  
**48 - Ground : Battery voltage**

OK or NG

OK >> GO TO 3.

NG >> Replace BCM. Refer to [BCS-26, "Removal and Installation of BCM"](#).

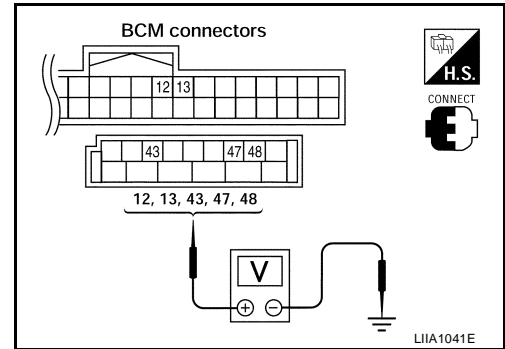

## 3. CHECK DOOR SWITCH CIRCUIT

1. Turn ignition switch OFF.
2. Disconnect door switch and BCM.
3. Check continuity between door switch connector B8 (Front LH), B108 (Front RH), B18 (Rear LH), B116 (Rear RH) terminal 2 or D502 (Back) terminal 3 and BCM connector M18, M19 terminals 12, 13, 43, 47 and 48.

**2 - 47 : Continuity should exist.**  
**2 - 12 : Continuity should exist.**  
**2 - 48 : Continuity should exist.**  
**2 - 13 : Continuity should exist.**  
**3 - 43 : Continuity should exist.**

4. Check continuity between door switch connector B8 (Front LH), B108 (Front RH), B18 (Rear LH), B116 (Rear RH) terminal 2 or D502 (Back) terminal 3 and ground.

**2 - Ground : Continuity should not exist.**  
**3 - Ground : Continuity should not exist.**

OK or NG

OK >> GO TO 4.

NG >> Repair or replace harness.

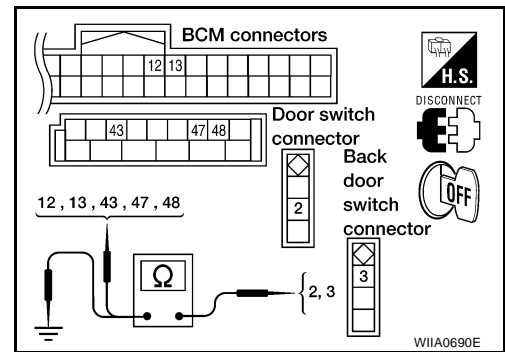

# VEHICLE SECURITY (THEFT WARNING) SYSTEM

## 4. CHECK DOOR SWITCHES

### FRONT AND REAR DOORS

Check continuity between front or rear door switch terminal 2 and exposed metal of switch while pressing and releasing switch.

**When front or rear door switch is released : Continuity should exist.**

**When front or rear door switch is pushed : Continuity should not exist.**

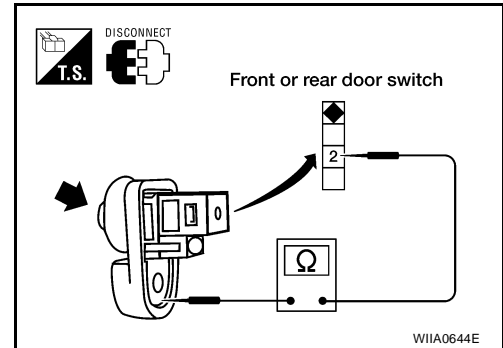

### BACK DOOR

Check continuity between back door switch terminals 3 and 1 while pressing and releasing switch.

**When back door switch is released : Continuity should exist.**

**When back door switch is pushed : Continuity should not exist.**

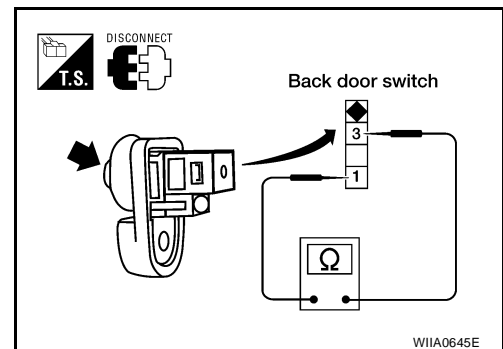

### OK or NG

- OK >> Check switch case ground condition (front and rear door) or ground circuit (back door).
- NG >> Replace door switch.

# VEHICLE SECURITY (THEFT WARNING) SYSTEM

EIS006D4

## Diagnostic Procedure 2

### SECURITY INDICATOR LAMP CHECK

#### 1. SECURITY INDICATOR LAMP ACTIVE TEST

① With CONSULT-II

Check "THEFT IND" in "ACTIVE TEST" mode with CONSULT-II.

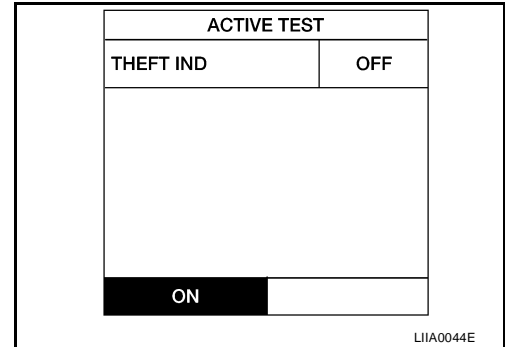

② Without CONSULT-II

1. Turn ignition switch OFF.
2. Check voltage between BCM harness connector M18 terminal 23 and ground.

Connector	Terminal		Security indicator lamp condition	Voltage (V) (Approx.)
	(+)	(-)		
M18	23	Ground	Illuminated	0
			Not illuminated	Battery voltage

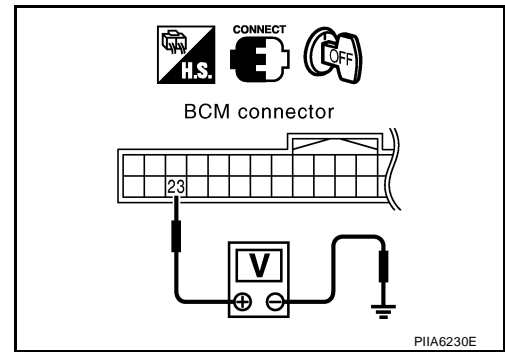

OK or NG

- OK >> Security indicator lamp is OK.
- NG >> GO TO 2.

#### 2. SECURITY INDICATOR LAMP CHECK

Check security indicator lamp condition. Refer to [DI-12, "SELF-DIAGNOSIS FUNCTION"](#) .

OK or NG

- OK >> GO TO 3.
- NG >> Replace combination meter. Refer to [DI-7, "Combination Meter"](#) .

# VEHICLE SECURITY (THEFT WARNING) SYSTEM

## 3. CHECK HARNESS CONTINUITY

1. Turn ignition switch OFF.
2. Disconnect BCM and combination meter connector.
3. Check continuity between BCM connector M18 terminal 23 and combination meter harness connector M24 terminal 39.

**23 - 39 : Continuity should exist.**

4. Check continuity between BCM connector M18 terminal 23 and ground.

**23 - Ground : Continuity should not exist.**

OK or NG

OK >> Check the following.

- 10A fuse [No. 19, located in fuse block (J/B)]
- Harness for open or short between combination meter and fuse

NG >> Repair or replace harness.

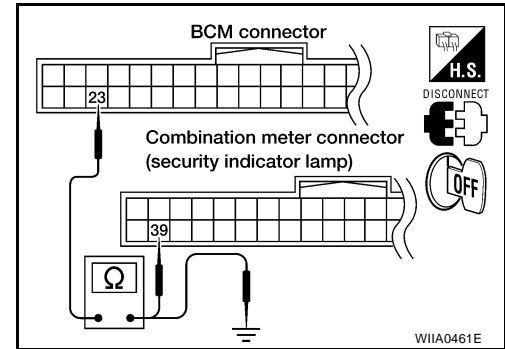

## Diagnostic Procedure 3

E/S006D5

### 1. CHECK FRONT DOOR KEY CYLINDER SWITCH LH AND BACK DOOR KEY CYLINDER SWITCH

Ⓜ With CONSULT-II

Check front door lock assembly LH (key cylinder switch) and back door key cylinder switch ("KEY CYL LK-SW") and ("KEY CYL UN-SW") with DATA MONITOR mode in CONSULT-II. Refer to [BL-27, "DATA MONITOR"](#).

- When key inserted in each key cylinder is turned to LOCK:

**KEY CYL LK-SW : ON**

- When key inserted in each key cylinder is turned to UNLOCK:

**KEY CYL UN-SW : ON**

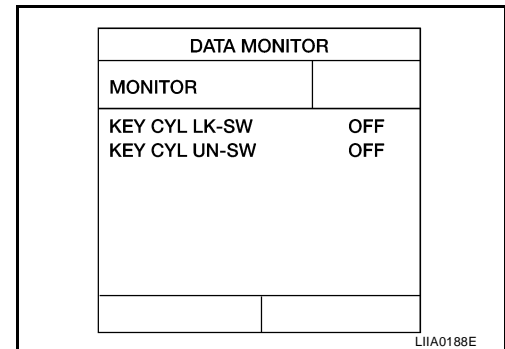

⊗ Without CONSULT-II

Check voltage between BCM connector M18 terminals 7, 8 and ground.

Connector	Terminals		Condition of each key cylinder switch	Voltage (V) (Approx.)
	(+)	(-)		
M18	7	Ground	Neutral/Lock	5
			Unlock	0
	8		Neutral/Unlock	5
			Lock	0

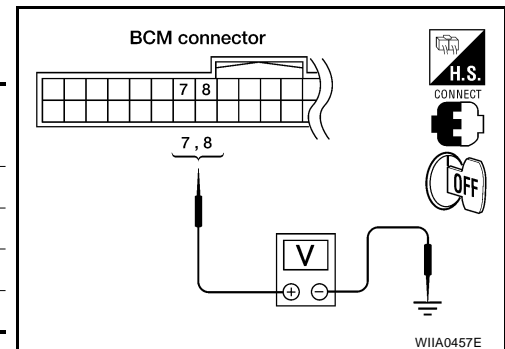

OK or NG

OK >> Key cylinder switch signal is OK.

NG >> GO TO 2.



# VEHICLE SECURITY (THEFT WARNING) SYSTEM

## 2. CHECK KEY CYLINDER SWITCH

1. Turn ignition switch OFF.
2. Disconnect key cylinder switches.
3. Check continuity between key cylinder switch terminals.

### Front

Terminals	Condition	Continuity
4 – 5	Key is turned to LOCK	Yes
	Key is in N position or turned to UNLOCK	No
3 – 4	Key is turned to UNLOCK	Yes
	Key is in N position or turned to LOCK	No

### Back

Terminals	Condition	Continuity
1 – 2	Key is turned to LOCK	Yes
	Key is in N position or turned to UNLOCK	No
3 – 2	Key is turned to UNLOCK	Yes
	Key is in N position or turned to LOCK	No

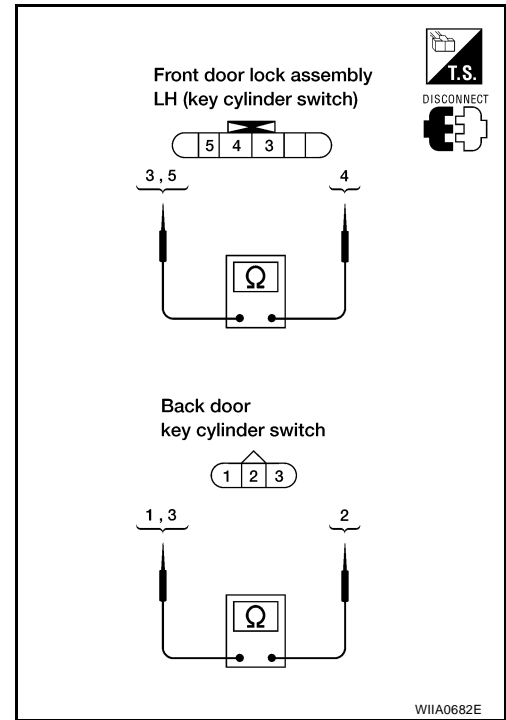

### OK or NG

- OK >> GO TO 3.
- NG >> Replace key cylinder switch. Refer to [BL-97, "Removal and Installation"](#) (front) or [BL-101, "Component Structure"](#) (back).

# VEHICLE SECURITY (THEFT WARNING) SYSTEM

## 3. CHECK KEY CYLINDER SWITCH HARNESS

1. Disconnect BCM.
2. Check continuity between BCM connector M18 terminals 7, 8 and front door lock assembly LH connector D14 terminals 3, 5.

**7 - 3** : Continuity should exist.

**8 - 5** : Continuity should exist.

3. Check continuity between BCM connector M18 terminals 7, 8 and back door key cylinder switch connector D505 terminals 3, 1.

**7 - 3** : Continuity should exist.

**8 - 1** : Continuity should exist.

4. Check continuity between BCM connector M18 terminals 7, 8 and ground.

**7 - Ground** : Continuity should not exist.

**8 - Ground** : Continuity should not exist.

OK or NG

OK >> GO TO 4.

NG >> Repair or replace harness.

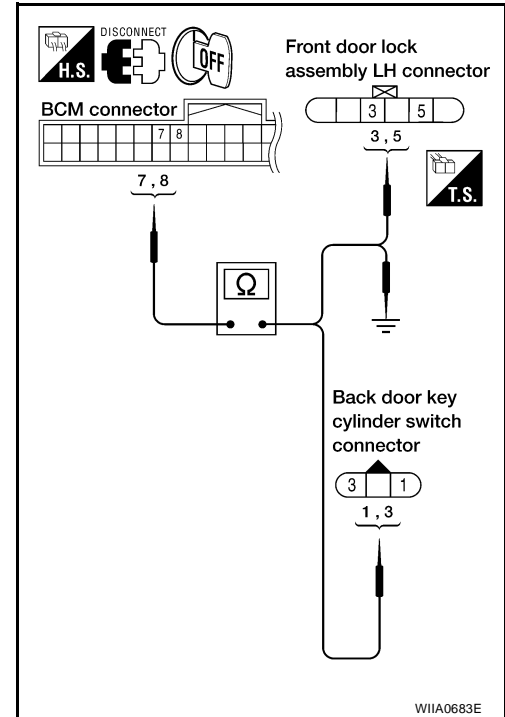

## 4. CHECK KEY CYLINDER SWITCH GROUND

1. Check continuity between front door lock assembly LH connector D14 terminal 4 and ground.

**4 - Ground** : Continuity should exist.

2. Check continuity between back door key cylinder switch connector D505 terminal 2 and ground.

**2 - Ground** : Continuity should exist.

OK or NG

OK >> GO TO 5.

NG >> Repair or replace harness.

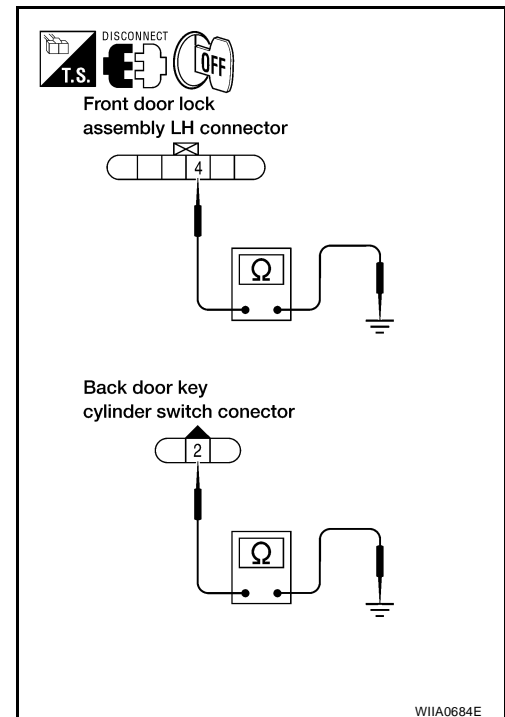

# VEHICLE SECURITY (THEFT WARNING) SYSTEM

## 5. CHECK BCM OUTPUT VOLTAGE

1. Connect BCM.
2. Check voltage between BCM connector M18 terminals 7, 8 and ground.

**7 - Ground : Approx. 5V**

**8 - Ground : Approx. 5V**

OK or NG

OK >> Check condition of the harness and connector.

NG >> Replace BCM. Refer to [BCS-26, "Removal and Installation of BCM"](#) .

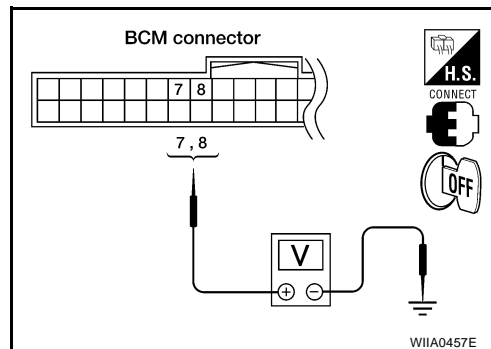

EIS006D6

## Diagnostic Procedure 4

VEHICLE SECURITY HORN ALARM CHECK

### 1. CHECK HORN OPERATION

Check if horn sounds with horn switch.

Does horn operate?

Yes >> Check harness for open or short between IPDM E/R and horn relay.

No >> Check horn circuit. Refer to [WW-50, "HORN"](#) .

## Diagnostic Procedure 5

EIS006D7

VEHICLE SECURITY HEADLAMP ALARM CHECK

### 1. CHECK VEHICLE SECURITY HEADLAMP ALARM OPERATION

Check if headlamps operate with lighting switch.

Do headlamps come on when turning switch ON?

Yes >> Headlamp alarm is OK.

No >> Check headlamp system. Refer to [LT-5, "HEADLAMP \(FOR USA\)"](#) .

## Diagnostic Procedure 6

EIS006D8

DOOR LOCK/UNLOCK SWITCH CHECK

### 1. CHECK DOOR LOCK/UNLOCK SWITCH INPUT SIGNAL

Check if power door lock operates with door lock/unlock switch.

Do doors lock/unlock when using each door lock/unlock switch?

Yes >> Door lock/unlock switch is OK.

No >> Refer to [BL-33, "Door Lock/Unlock Switch Check"](#) .

# DOOR

## DOOR

PFP:80100

### Fitting Adjustment

EIS0065C

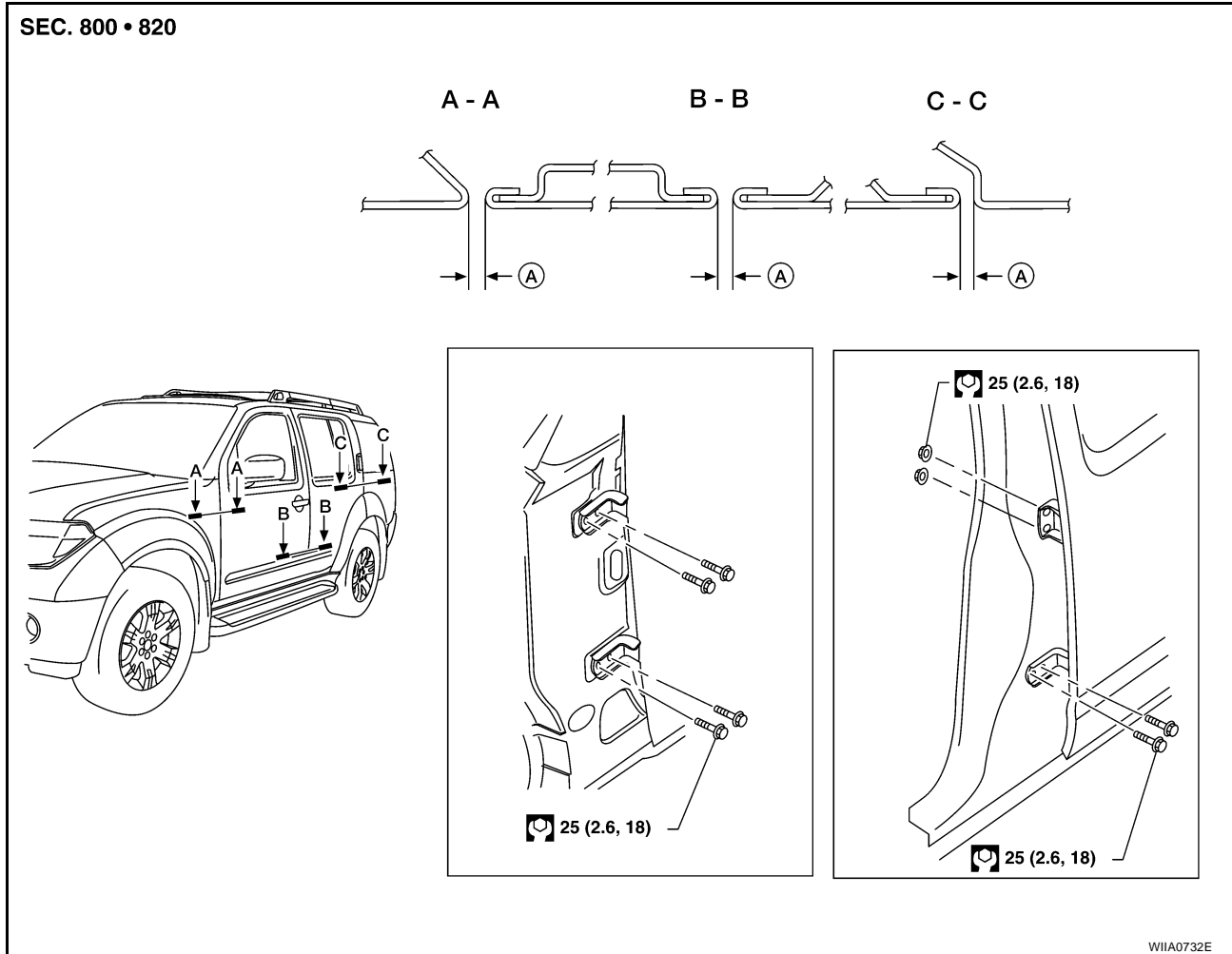

A.  $4.5 \pm 1.0 \text{ mm}$  ( $0.177 \pm 0.039 \text{ in}$ )

### FRONT DOOR

#### Longitudinal Clearance and Surface Height Adjustment at Front End

1. Remove the fender. Refer to [EI-18, "FRONT FENDER"](#) .
2. Loosen the hinge bolts. Raise or lower the front door at rear end to adjust.
3. Install the fender. Refer to [EI-18, "FRONT FENDER"](#) .

### REAR DOOR

#### Longitudinal clearance and surface height adjustment at front end

1. Remove the center pillar upper finisher. Refer to [EI-27, "BODY SIDE TRIM"](#) .
2. Loosen the lower hinge bolts.
3. From inside the vehicle, loosen the upper hinge nuts. Open the door, and raise or lower the rear end of the door to adjust.
4. Install the center pillar lower finisher. Refer to [EI-27, "BODY SIDE TRIM"](#) .

# DOOR

## BACK DOOR

### Longitudinal Clearance and Surface Height Adjustment

SEC. 900

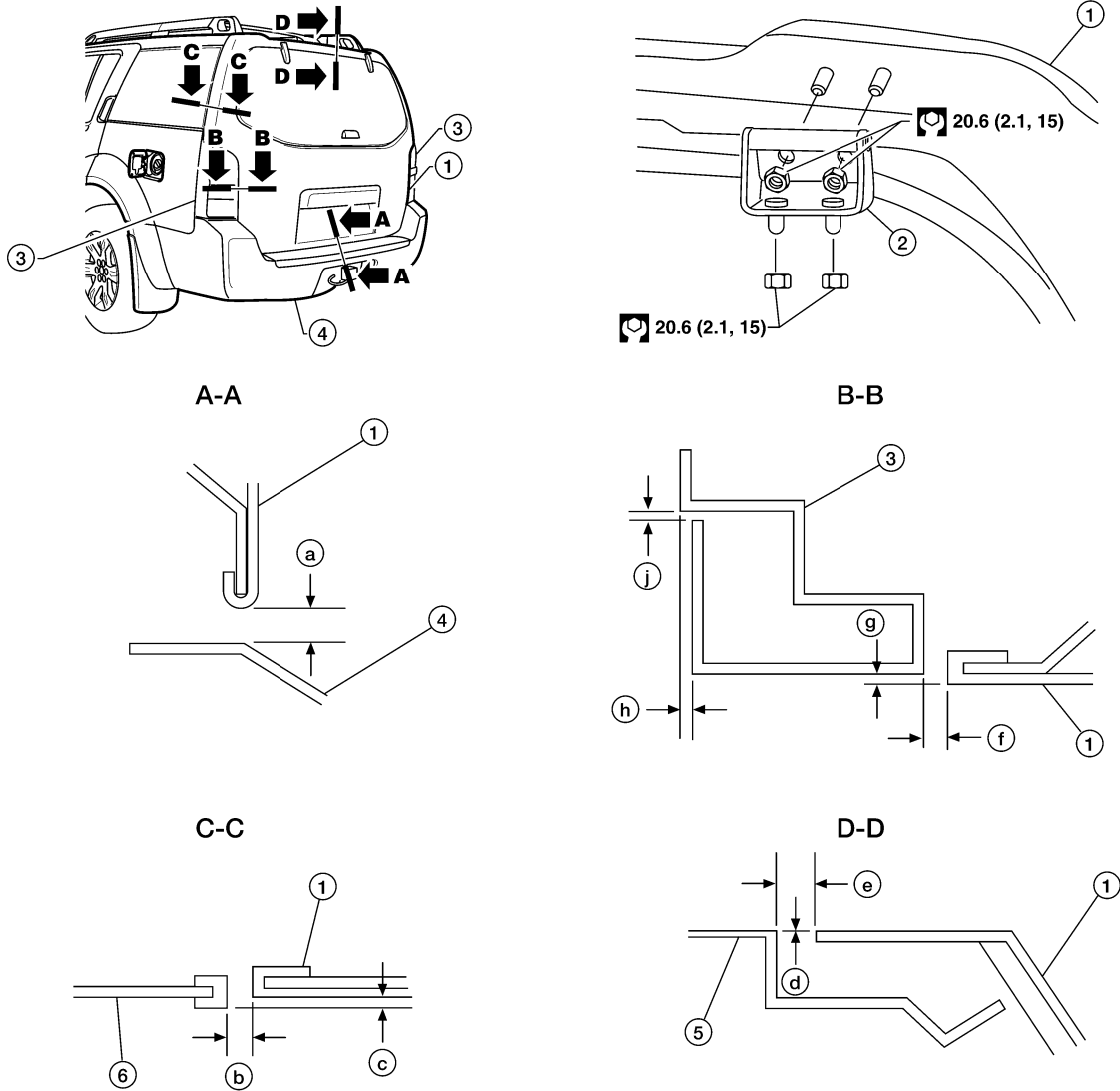

WI1A0733E

- |   |   |   |
|---|---|---|
| 1. Back door assembly                     | 2. Back door hinge                        | 3. Tail lamp assembly                     |
| 4. Rear bumper fascia                     | 5. Roof                                   | 6. Side window glass                      |
| a. $7.2 \pm 2.0$ mm ( $0.28 \pm 0.06$ in) | b. $6.0 \pm 1.5$ mm ( $0.24 \pm 0.06$ in) | c. $2.0 \pm 2.0$ mm ( $0.08 \pm 0.08$ in) |
| d. $1.0 \pm 1.5$ mm ( $0.04 \pm 0.06$ in) | e. $8.0 \pm 1.5$ mm ( $0.31 \pm 0.06$ in) | f. $5.3 \pm 2.0$ mm ( $0.21 \pm 0.08$ in) |
| g. $0.8 \pm 2.0$ mm ( $0.03 \pm 0.08$ in) | h. $0.8 \pm 1.0$ mm ( $0.03 \pm 0.04$ in) | j. $2.0 \pm 1.0$ mm ( $0.08 \pm 0.04$ in) |

1. Open and support the back door.
2. Slightly loosen the hinge nuts.
3. Reposition the door as necessary and tighten the nuts.
4. Confirm the adjustment. Repeat as necessary to obtain the desired fit.

# DOOR

## STRIKER ADJUSTMENT

### Body Side Doors

1. Adjust the striker so that it becomes parallel with the lock insertion direction.

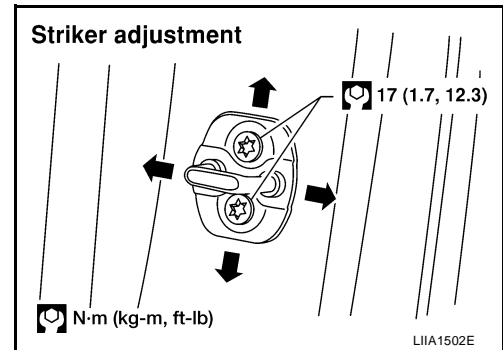

### Back Door

1. Adjust the striker so that it becomes parallel with the lock insertion direction.

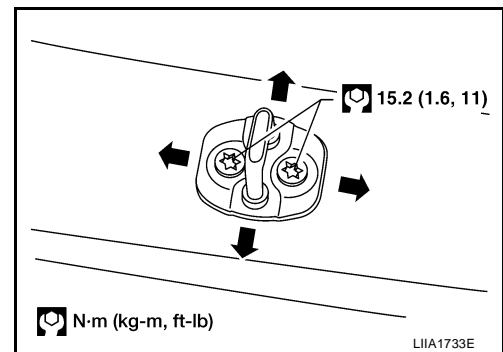

## Removal and Installation FRONT DOOR

### CAUTION:

- When removing and installing the door assembly, support the door with a jack and shop cloth to protect the door and body.
  - When removing and installing door assembly, be sure to carry out the fitting adjustment.
  - Check the hinge rotating part for poor lubrication. If necessary, apply "body grease".
1. Remove the front door glass and regulator. Refer to [GW-51, "FRONT DOOR GLASS AND REGULATOR"](#).
  2. Remove the door harness.
  3. Remove the check link bolt from the hinge pillar.

**Check link to lock pillar bolt**     **14.7 N·m (1.5 kg-m, 11 ft-lb)**

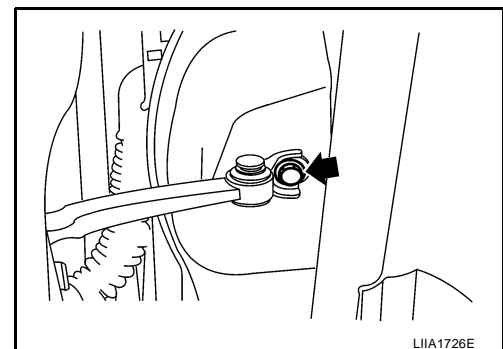

# DOOR

4. Remove the door hinge nuts, and the door assembly.

**Door hinge nuts**                      **24.5 N-m (2.5 kg-m, 18 ft-lb)**

5. Install in the reverse order of removal.

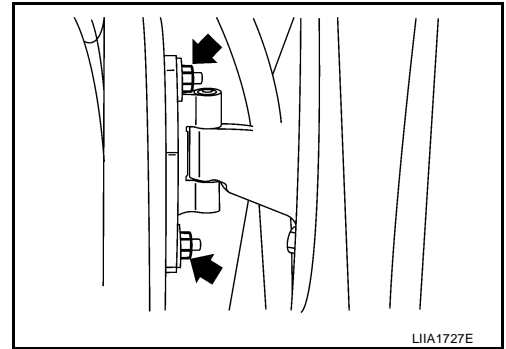

## REAR DOOR

1. Remove the door finisher. Refer to [EI-24, "DOOR FINISHER"](#) .
2. Remove the inner seal.
3. Remove the rear door glass and regulator. Refer to [GW-55, "REAR DOOR GLASS AND REGULATOR"](#) .
4. Remove the door harness.
5. Remove the check link bolt from the hinge pillar.

**Check link to hinge pillar bolt**    **14.7 N-m (1.5 kg-m, 11 ft-lb)**

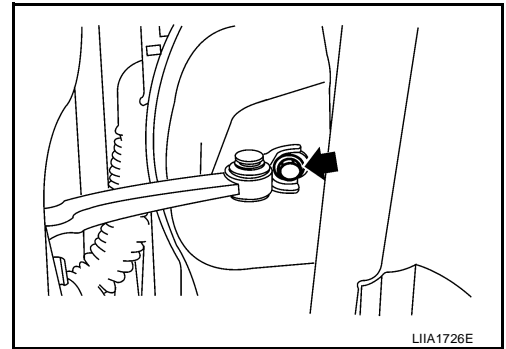

6. Remove the door hinge nuts, and remove the door assembly.

**Door hinge nuts**                      **24.5 N-m (2.5 kg-m, 18 ft-lb)**

7. Install in the reverse order of removal.

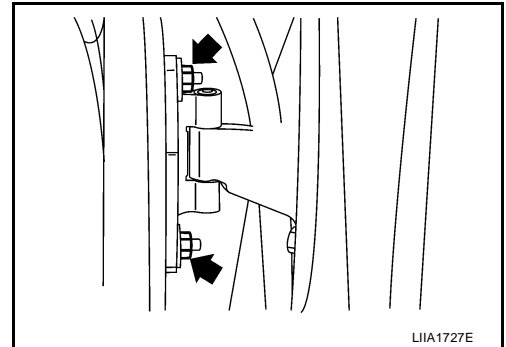

## BACK DOOR

1. Remove the glass hatch. Refer to [GW-61, "Removal and Installation"](#) .
2. Remove the back door lock assembly. Refer to [BL-101, "BACK DOOR LOCK"](#) .
3. Remove the back door wire harness.
4. Remove the rear washer nozzle and hose from the back door. Refer to [WW-46, "REAR WASHER NOZZLE"](#) .
5. Support the back door.  
**CAUTION:**  
**Two technicians should be used to avoid damaging the back door during removal.**
6. Remove the back door stays.

# DOOR

7. Remove the door side nuts and the back door assembly.

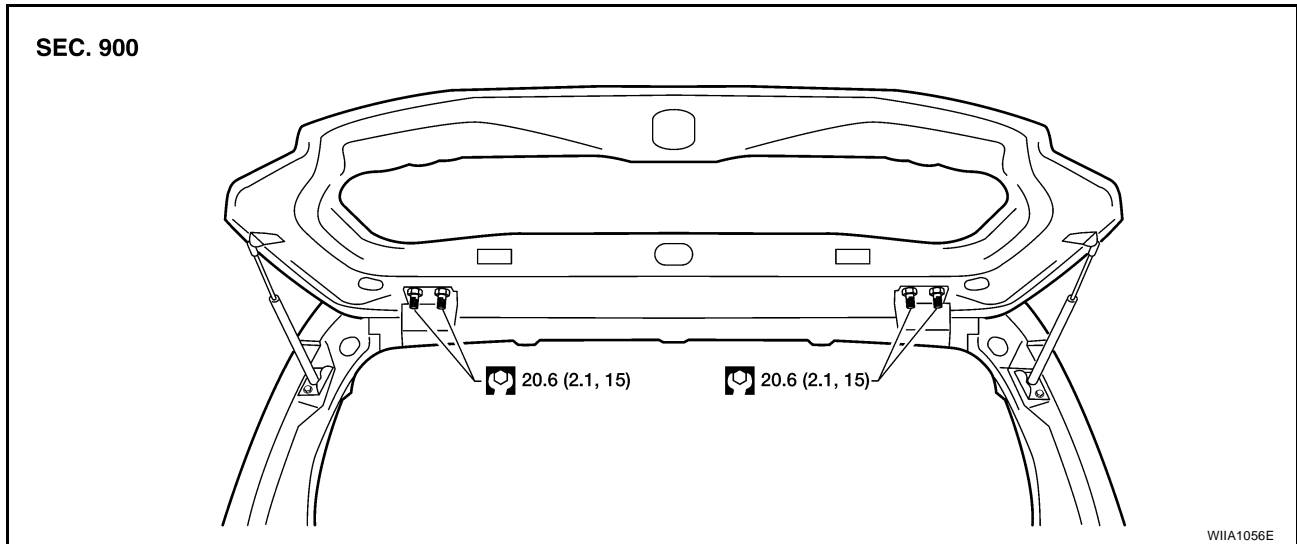

8. Installation is in the reverse order of removal.
  - Align the back door. Refer to [BL-92, "Fitting Adjustment"](#) .



# FRONT DOOR LOCK

PFP:80502

## FRONT DOOR LOCK Component Structure

EIS0065E

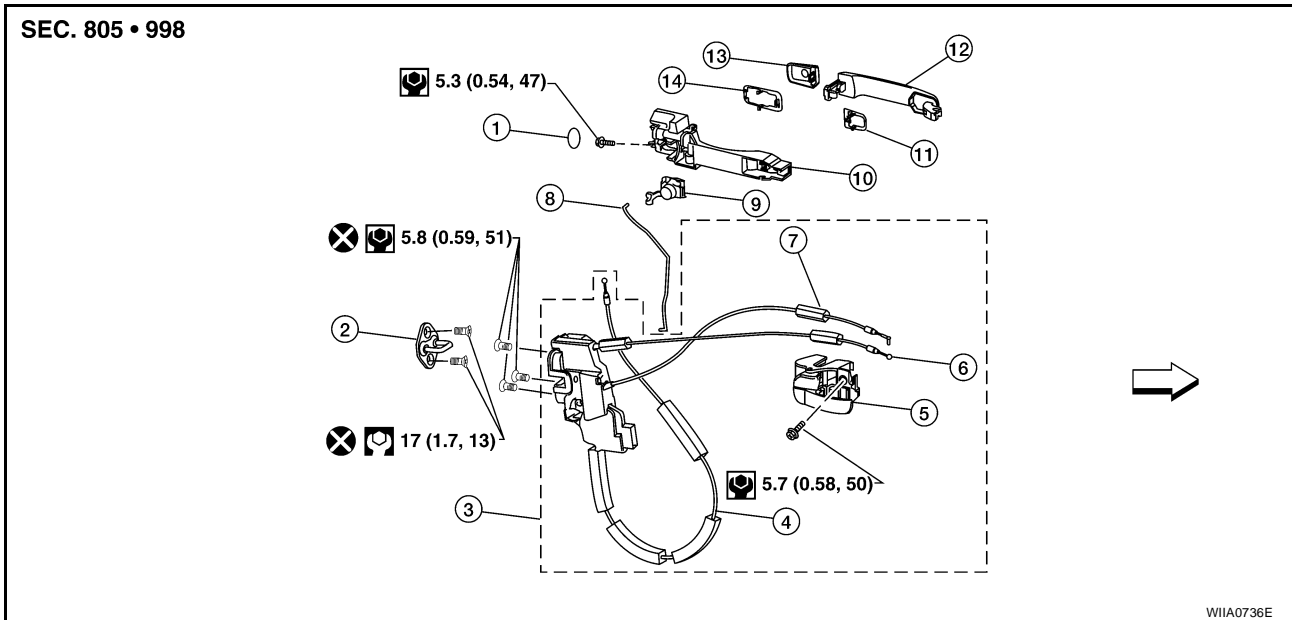

- |   |  |                        |
|---|--|------------------------|
| 1. Grommet  | 2. Front door striker                  | 3. Door lock assembly  |
| 4. Outside handle cable   | 5. Inside handle assembly              | 6. Inside handle cable |
| 7. Door lock cable  | 8. Key cylinder rod (Driver side only) | 9. Door key cylinder   |
| 10. Outside handle bracket  | 11. Front gasket                       | 12. Outside handle     |
| 13. Door key cylinder assembly (Driver side) Outside handle escutcheon (Passenger side) | 14. Rear gasket                        | ← Vehicle front        |

## Removal and Installation REMOVAL

EIS0065F

1. Remove the front door window regulator. Refer to [GW-51, "Front Door Glass"](#).
2. Remove door side grommet, and remove door key cylinder assembly (driver side) or outside handle escutcheon (passenger side) bolts (TORX T30) from grommet hole.

### CAUTION:

Do not forcibly remove the TORX bolts (T30).

**TORX bolt**

**5.3 N·m (0.54 kg·m, 47 in-lb)**

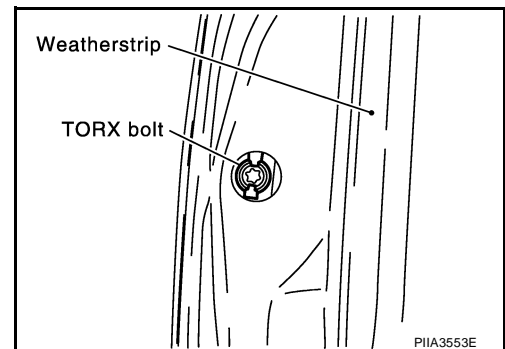

3. Separate the key cylinder rod (driver side only) and outside handle rod connection (on the handle).

# FRONT DOOR LOCK

4. While pulling the outside handle, remove door key cylinder assembly or escutcheon.

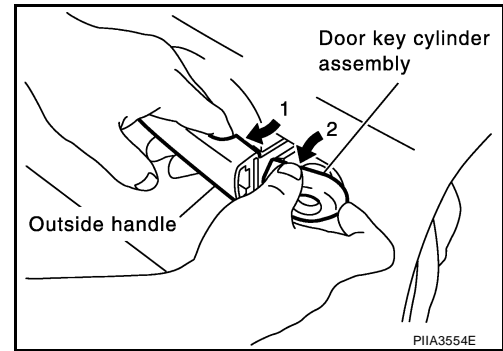

5. While pulling outside handle, slide toward rear of vehicle to remove outside handle.

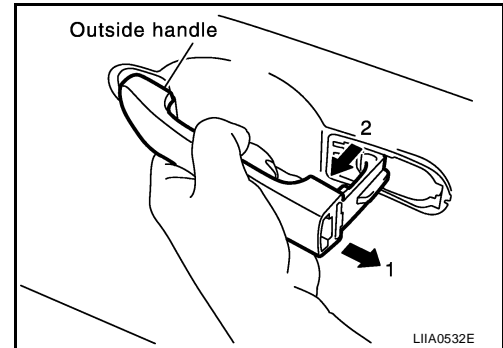

6. Remove the front gasket and rear gasket.

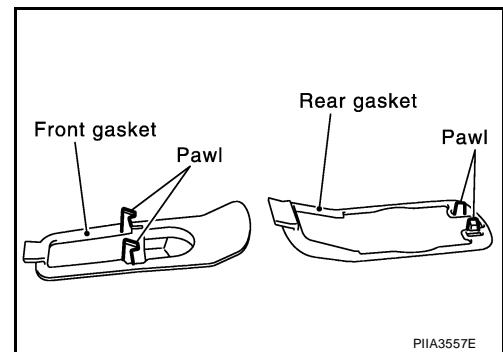

7. Remove the door lock assembly TORX bolts (T30) and the door lock assembly.

**Door lock assembly bolts 7.5 N-m (0.77 kg-m, 00 in-lb)**

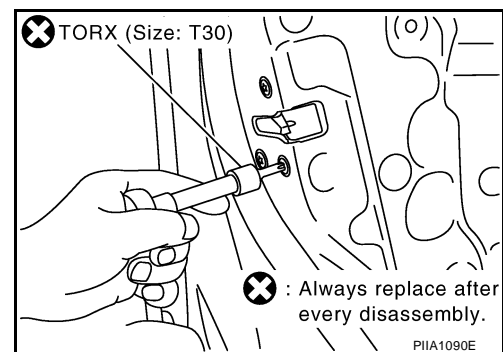

8. While pulling outside handle bracket, slide toward rear of vehicle to remove outside handle bracket and door lock assembly.

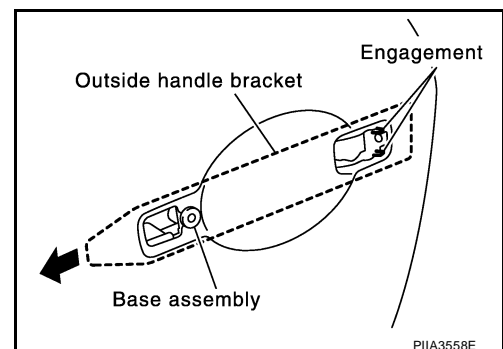

# FRONT DOOR LOCK

9. Disconnect the door lock actuator connector.

## INSTALLATION

Installation in the reverse order of removal.

### CAUTION:

To install each rod, be sure to rotate the rod holder until a click is felt.

## Disassembly and Assembly DOOR KEY CYLINDER ASSEMBLY

EIS0065G

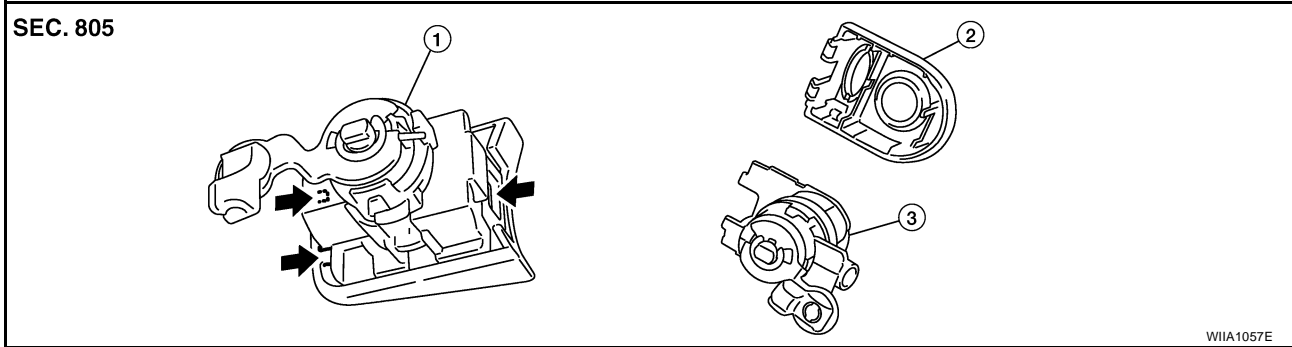

1. Door key cylinder assembly

2. Key cylinder escutcheon

3. Door key cylinder

← Pawl

Remove the key cylinder escutcheon pawl and remove the door key cylinder.

A  
B  
C  
D  
E  
F  
G  
H  
J  
K  
L  
M

BL

# REAR DOOR LOCK

## REAR DOOR LOCK

PFP:82502

### Component Structure

EIS0065H

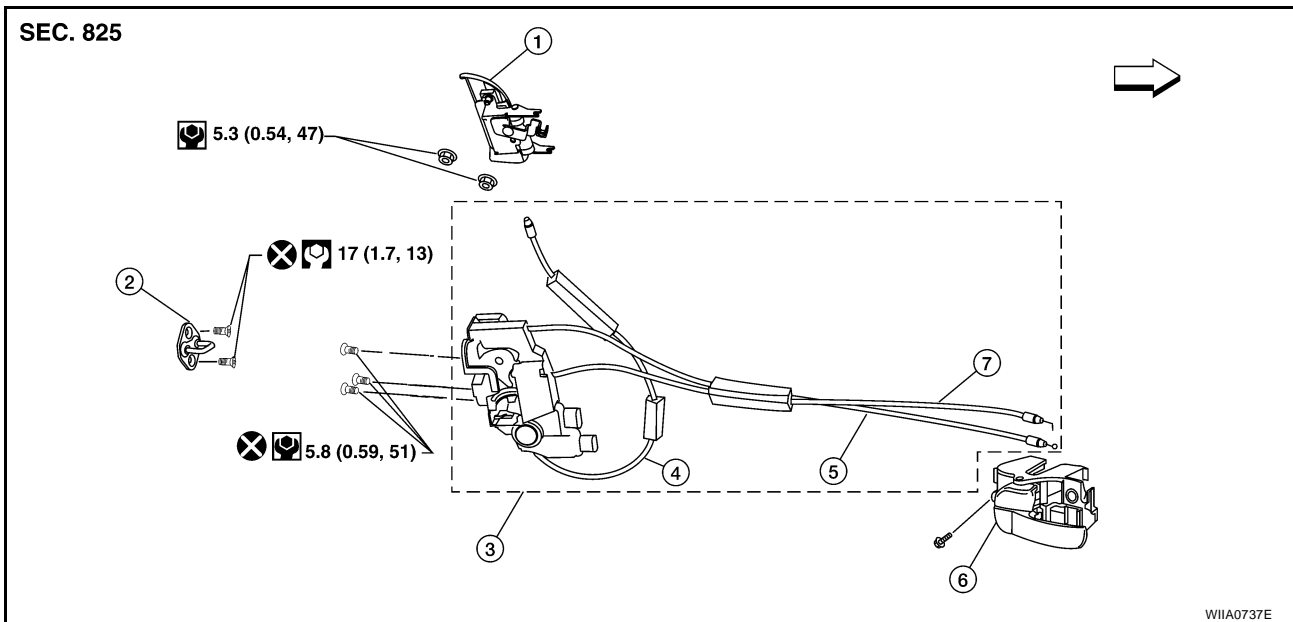

- |                              |                             |                                |
|------------------------------|-----------------------------|--------------------------------|
| 1. Outside door handle       | 2. Rear door striker        | 3. Rear door lock assembly     |
| 4. Outside door handle cable | 5. Inside door handle cable | 6. Inside door handle assembly |
| 7. Door lock cable           | ← Vehicle front             |                                |

## Removal and Installation

### REMOVAL

1. Remove the rear door window regulator. Refer to [GW-55, "Rear Door Glass"](#).
2. Remove door grommets, and remove outside handle nuts from the hole.
3. Remove outside handle.
4. Disconnect the outside handle cable connection.
5. Remove the inside door handle.
6. Disconnect the door lock and inside door handle cables from the inside door handle.
7. Disconnect the door lock actuator connector and remove the assembly.

### INSTALLATION

Installation is in the reverse order of removal.

EIS0065I

# BACK DOOR LOCK

## BACK DOOR LOCK Component Structure

PF9:90504

E/S0065J

SEC. 905

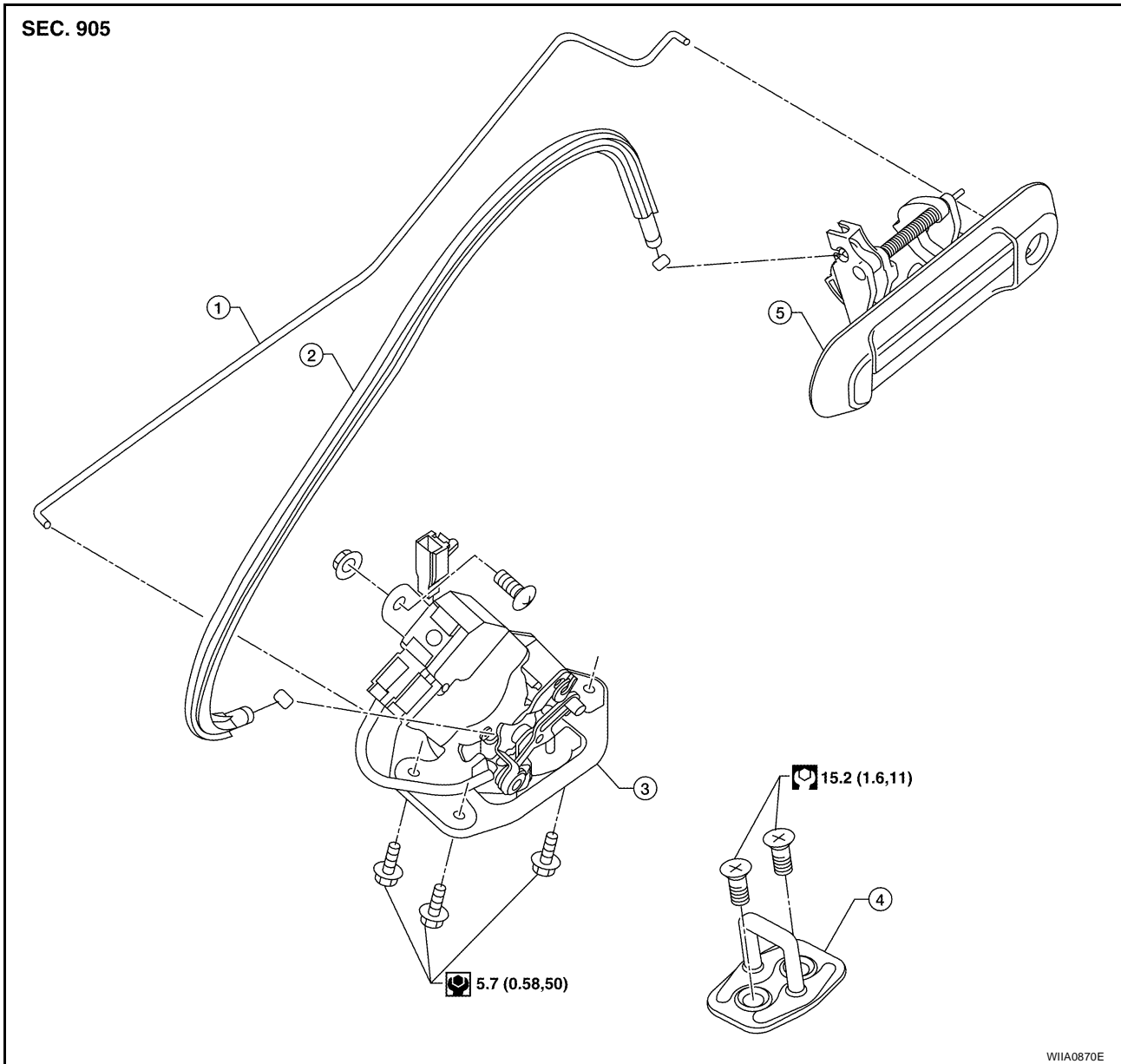

1. Back door lock rod

2. Back door latch cable

3. Back door latch

4. Back door striker

5. Back door release handle

WIA0870E

A  
B  
C  
D  
E  
F  
G  
H  
BL  
J  
K  
L  
M

# NVIS(NISSAN VEHICLE IMMOBILIZER SYSTEM-NATS)

## NVIS(NISSAN VEHICLE IMMOBILIZER SYSTEM-NATS)

PF2:28591

### Component Parts and Harness Connector Location

EIS006D9

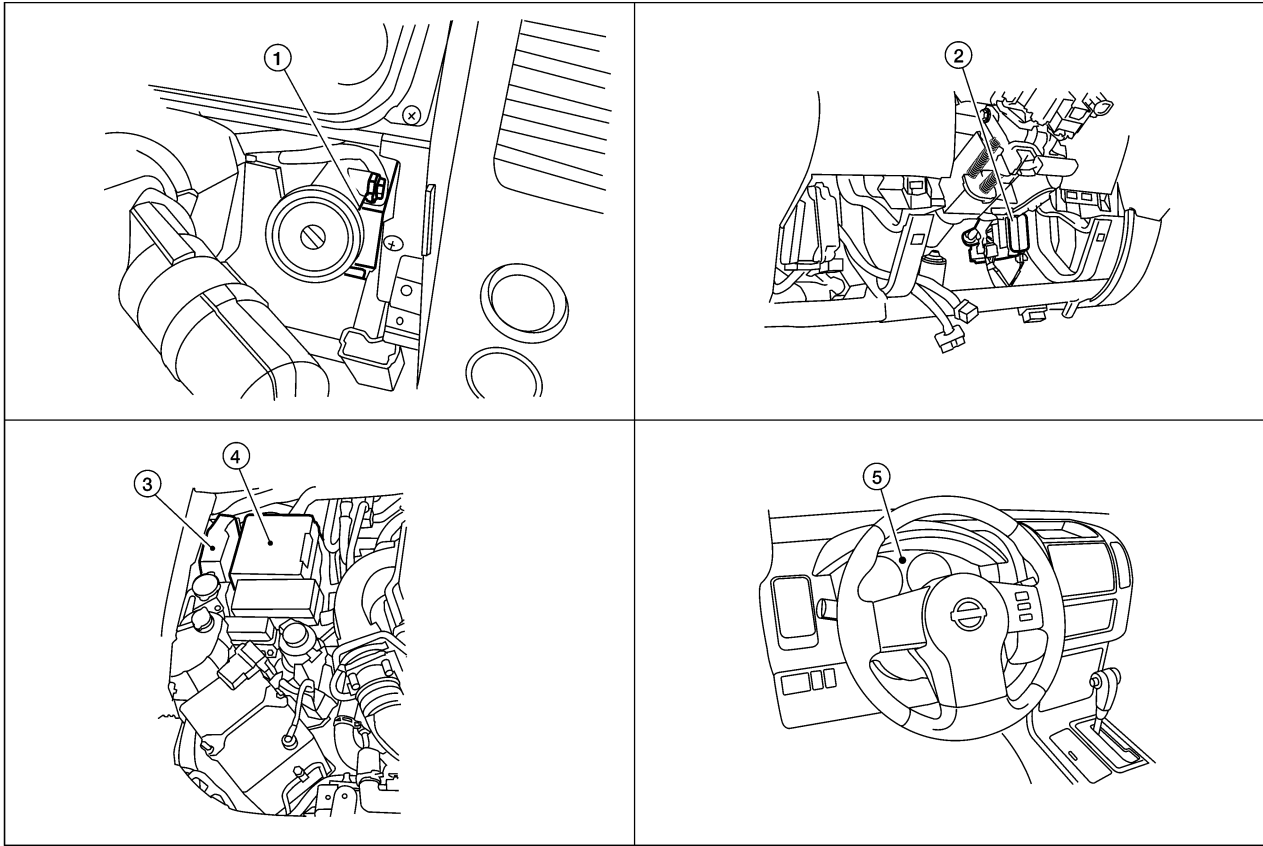

LIA2428E

- |   |  |            |
|---|--|------------|
| 1. NATS antenna amp. M21<br>(View with cluster lid A removed) | 2. BCM M18, M20<br>(View with instrument lower panel LH removed) | 3. ECM E16 |
| 4. IPDM E/R E121  | 5. Combination meter M24   |            |

# NVIS(NISSAN VEHICLE IMMOBILIZER SYSTEM-NATS)

EIS006DA

## System Description

NVIS (Nissan Vehicle Immobilizer System-NATS) has the following immobilizer functions:

- Since only NVIS (NATS) ignition keys, whose IDs have been registered into the ECM and BCM, allow the engine to run, operation of a stolen vehicle without a NVIS (NATS) registered key is prevented by NVIS (NATS).  
NVIS (NATS) will immobilize the engine if someone tries to start it without the registered key of NVIS (NATS).
- All of the originally supplied ignition key IDs have been NVIS (NATS) registered.  
If requested by the vehicle owner, a maximum of five key IDs can be registered into the NVIS (NATS) components.
- The security indicator blinks when the ignition switch is in OFF or ACC position. NVIS (NATS) warns outsiders that the vehicle is equipped with the anti-theft system.
- When NVIS (NATS) detects a malfunction, the security indicator lamp lights up while ignition key is in the ON position.
- NVIS (NATS) trouble diagnoses, system initialization and additional registration of other NVIS (NATS) ignition key IDs must be carried out using CONSULT-II hardware and CONSULT-II NVIS (NATS) software. When NVIS (NATS) initialization has been completed, the ID of the inserted ignition key is automatically NVIS (NATS) registered. Then, if necessary, additional registration of other NVIS (NATS) ignition key IDs can be carried out.  
Regarding the procedures of NVIS (NATS) initialization and NVIS (NATS) ignition key ID registration, refer to CONSULT-II Operation Manual NATS-IVIS/NVIS.
- **When servicing a malfunction of the NVIS (NATS) (indicated by lighting up of Security Indicator Lamp) or registering another NVIS (NATS) ignition key ID, it may be necessary to re-register original key identification. Therefore, be sure to receive ALL KEYS from vehicle owner.**

## System Composition

EIS006DB

The immobilizer function of the NVIS (NATS) consists of the following:

- NATS ignition key
- NATS antenna amp. located in the ignition key cylinder
- Body control module (BCM)
- Engine control module (ECM)
- Security indicator

### NOTE:

The communication between ECM and BCM uses the CAN communication system.

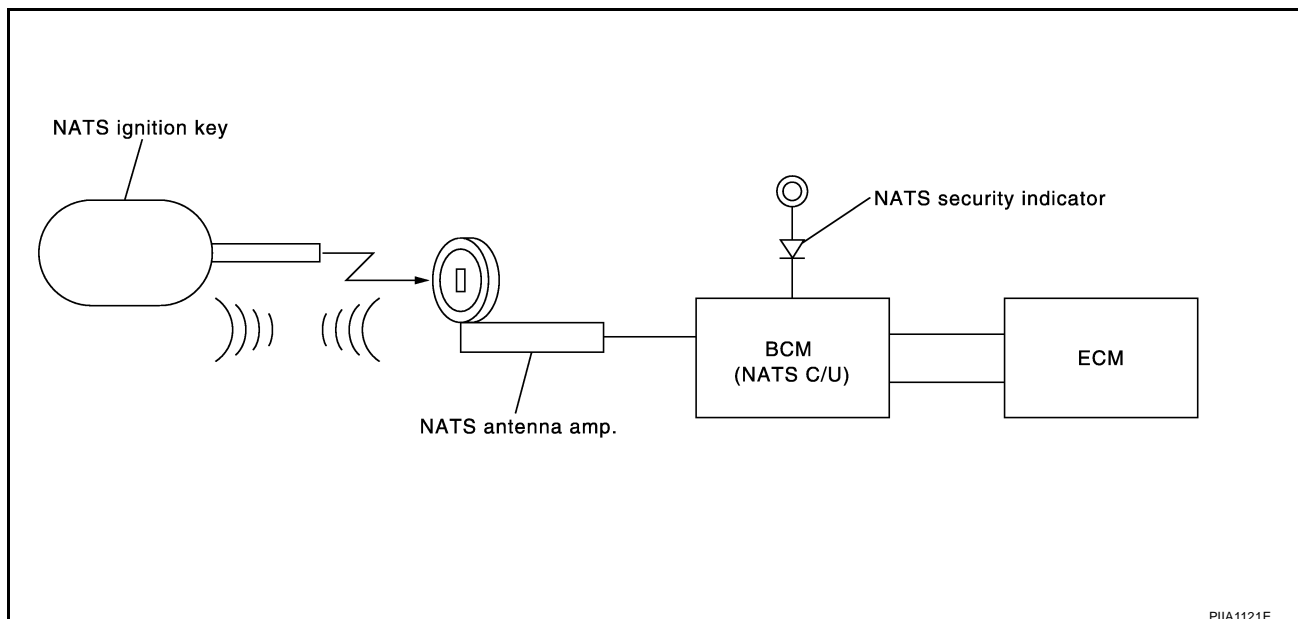

PIIA1121E

# NVIS(NISSAN VEHICLE IMMOBILIZER SYSTEM-NATS)

EIS006DC

## ECM Re-communicating Function

The following procedure can automatically perform re-communication of ECM and BCM, but only when the ECM has been replaced with a new one which has never been energized on-board.  
(In this step, initialization procedure by CONSULT-II is not necessary)

### NOTE:

- **When registering new key IDs or replacing the ECM other than brand new, refer to CONSULT-II Operation Manual NATS-IVIS/NVIS.**
- **If multiple keys are attached to the key holder, separate them before work.**
- **Distinguish keys with unregistered key ID from those with registered ID.**

1. Install ECM.
2. Using a registered key (\*1), turn ignition switch to ON.  
\*1: To perform this step, use the key that has been used before performing ECM replacement.
3. Maintain ignition switch in ON position for at least 5 seconds.
4. Turn ignition switch to OFF.
5. Start engine.

If engine can be started, procedure is completed.

If engine cannot be started, refer to CONSULT-II Operation Manual NATS-IVIS/NVIS and initialize control unit.



# NVIS(NISSAN VEHICLE IMMOBILIZER SYSTEM-NATS)

## Wiring Diagram — NATS —

EIS006DD

### BL-NATS-01

— : DATA LINE

REFER TO "PG-POWER".

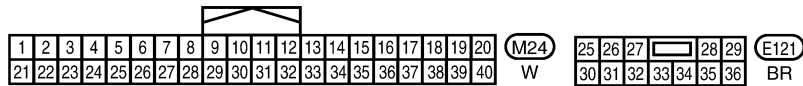
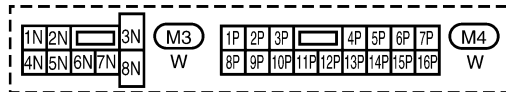
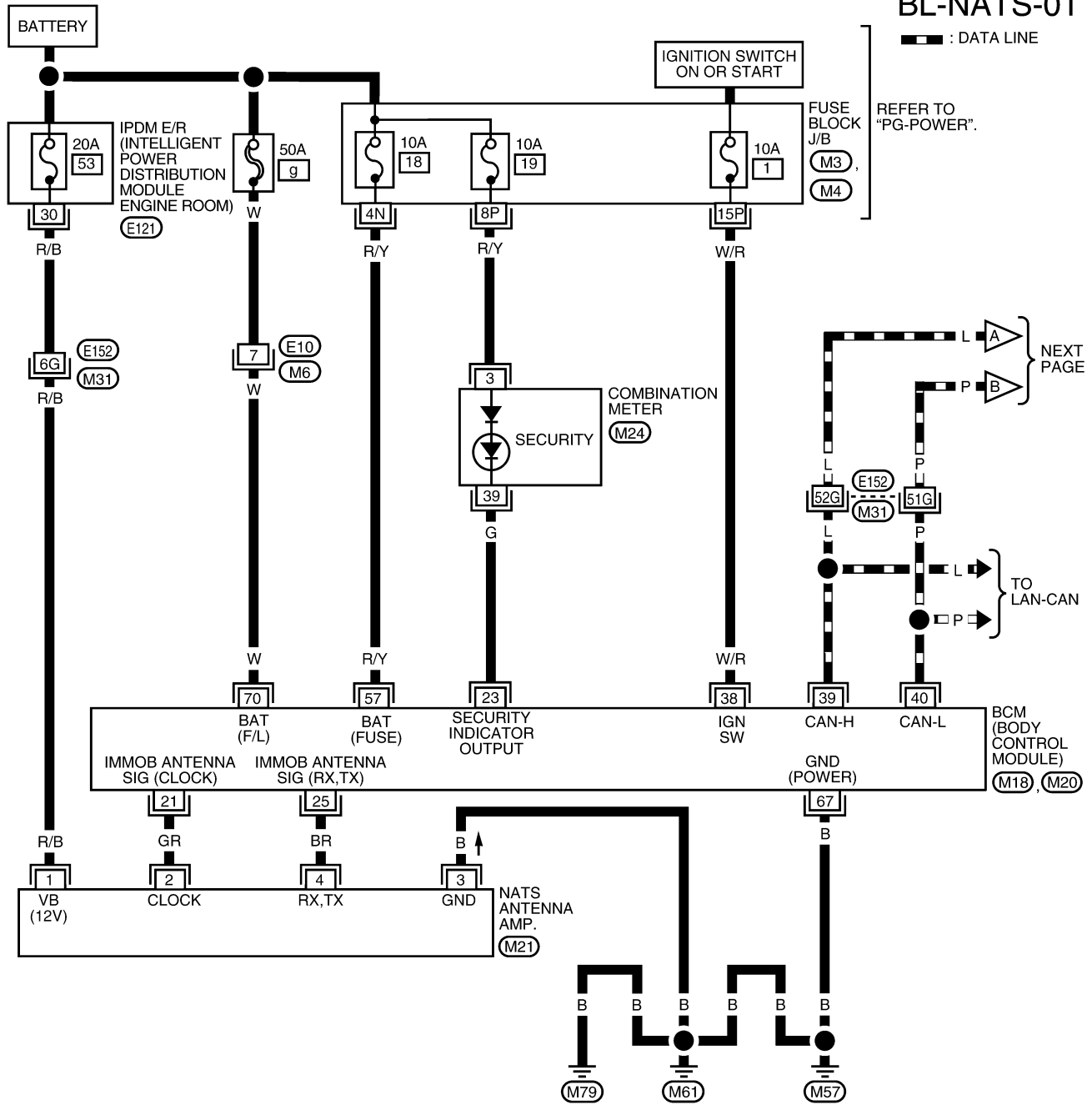

REFER TO THE FOLLOWING.

(M18), (M20) - ELECTRICAL UNITS

(M31) - SUPER MULTIPLE JUNCTION (SMJ)

WIWA1697E

# NVIS(NISSAN VEHICLE IMMOBILIZER SYSTEM-NATS)

## BL-NATS-02

-  : DATA LINE
-  : WITH A/T
-  : WITH M/T

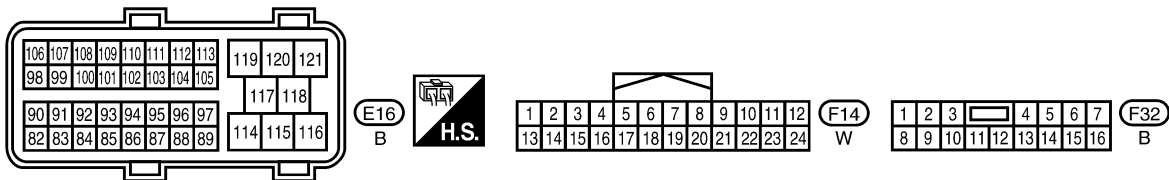
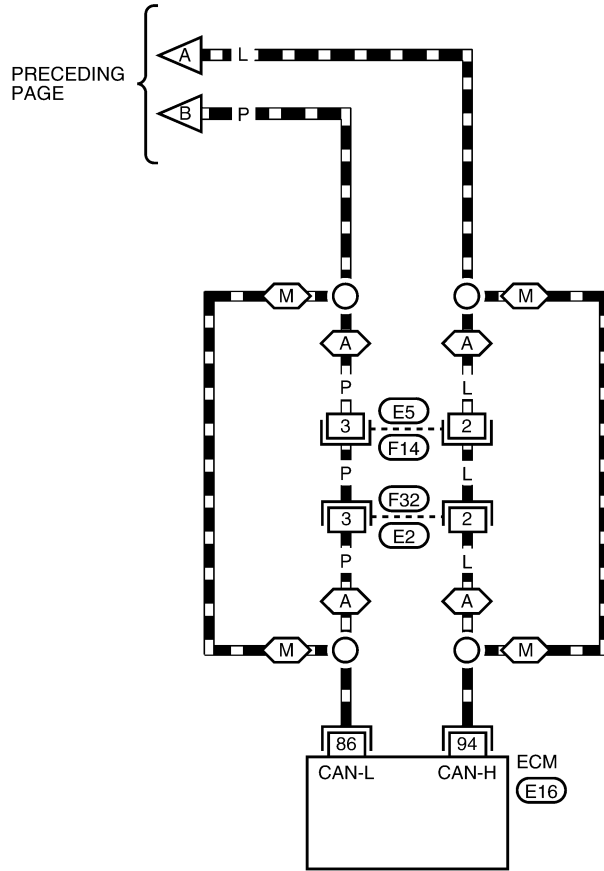

WIWA0829E

# NVIS(NISSAN VEHICLE IMMOBILIZER SYSTEM-NATS)

## Terminals and Reference Value for BCM

EIS006DE

Refer to [BCS-12, "Terminals and Reference Values for BCM"](#) .

## CONSULT-II

EIS006DF

### CONSULT-II INSPECTION PROCEDURE

#### CAUTION:

If CONSULT-II is used with no connection of CONSULT-II CONVERTER, malfunctions might be detected in self-diagnosis depending on control unit which carries out CAN communication.

1. Turn ignition switch OFF.
2. Insert NVIS (NATS) program card into CONSULT-II.

**Program card : NATS (AEN04A-1) or later**

3. Connect CONSULT-II and CONSULT-II CONVERTER to data link connector.
4. Turn ignition switch ON.

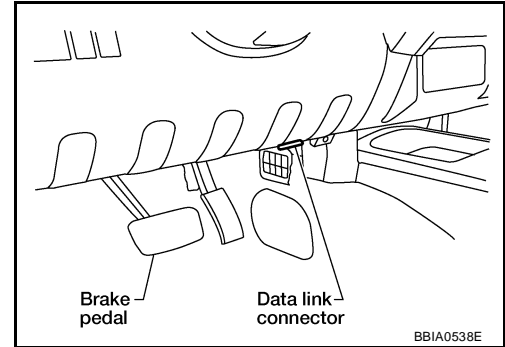

5. Touch "START".

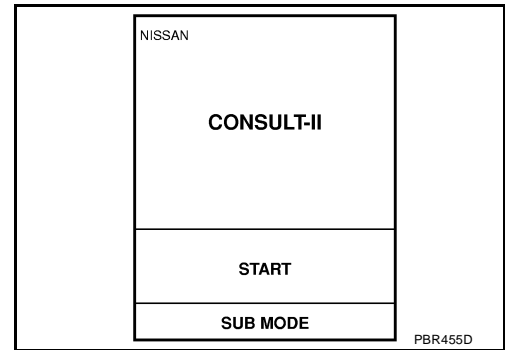

6. Touch "OTHER".

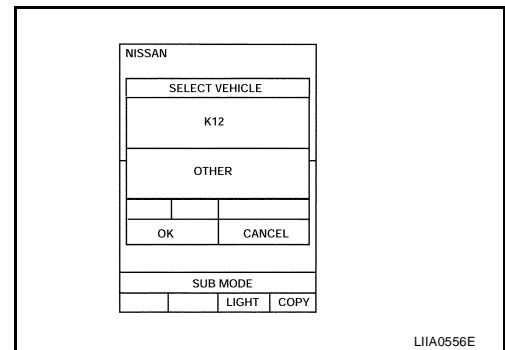

7. Select "NATS V.5.0".  
If "NATS V.5.0" is not indicated, go to [GI-41, "CONSULT-II Data Link Connector \(DLC\) Circuit"](#) .

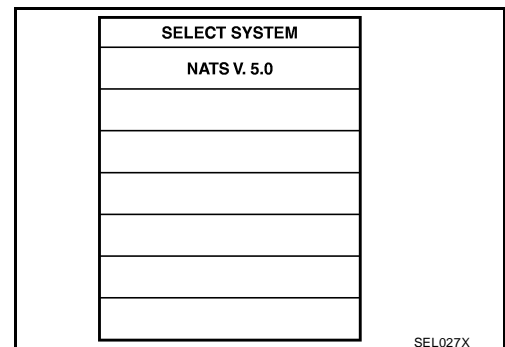



# NVIS(NISSAN VEHICLE IMMOBILIZER SYSTEM-NATS)

## NVIS (NATS) SELF-DIAGNOSTIC RESULTS ITEM CHART

Detected items [NVIS (NATS) program card screen terms]	P No. Code (Self-diagnostic result of "ENGINE")	Malfunction is detected when.....	Reference page
CHAIN OF ECM-IMMU [P1612]	NATS MAL- FUNCTION P1612	Communication impossible between ECM and BCM In rare case, "CHAIN OF ECM-IMMU" might be stored during key registration procedure, even if the system is not malfunctioning.	Refer to <a href="#">BL-113</a> .
DIFFERENCE OF KEY [P1615]	NATS MAL- FUNCTION P1615	BCM can receive the key ID signal but the result of ID verification between key ID and BCM is NG.	Refer to <a href="#">BL-114</a> .
CHAIN OF IMMU-KEY [P1614]	NATS MAL- FUNCTION P1614	BCM cannot receive the key ID signal.	Refer to <a href="#">BL-117</a> .
ID DISCORD, IMM-ECM [P1611]	NATS MAL- FUNCTION P1611	The result of ID verification between BCM and ECM is NG. System initialization is required.	Refer to <a href="#">BL-115</a> .
LOCK MODE [P1610]	NATS MAL- FUNCTION P1610	When the starting operation is carried out five or more times consecutively under the following conditions, NVIS (NATS) will shift the mode to one which prevents the engine from being started. <ul style="list-style-type: none"> <li>● Unregistered ignition key is used.</li> <li>● BCM or ECM malfunctioning.</li> </ul>	Refer to <a href="#">BL-116</a> .
DON'T ERASE BEFORE CHECK- ING ENG DIAG	—	All engine trouble codes except NVIS (NATS) trouble code has been detected in ECM.	Refer to <a href="#">BL-110</a> .

A  
B  
C  
D  
E  
F  
G  
H  
J  
K  
L  
M

BL

# NVIS(NISSAN VEHICLE IMMOBILIZER SYSTEM-NATS)

EIS006DG

## Work Flow

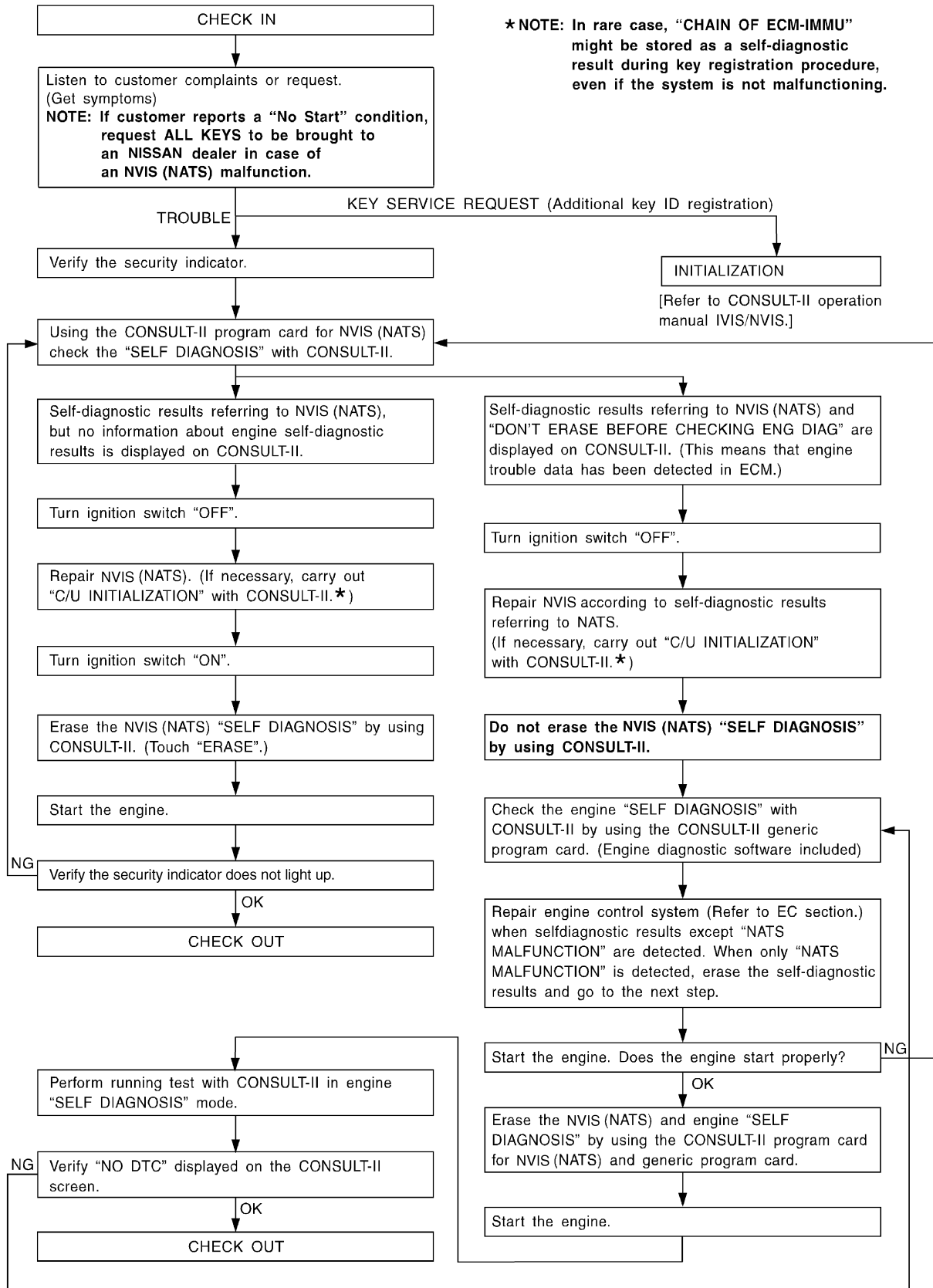

LIA1152E

# NVIS(NISSAN VEHICLE IMMOBILIZER SYSTEM-NATS)

EIS006DH

## Trouble Diagnoses SYMPTOM MATRIX CHART 1

### Self-diagnosis related item

Symptom	Displayed "SELF-DIAG RESULTS" on CONSULT-II screen.	Diagnostic Procedure (Reference page)	System (Malfunctioning part or mode)	Reference Part No. Of Illustration On System Diagram
<ul style="list-style-type: none"> <li>● Security indicator lighting up*</li> <li>● Engine cannot be started</li> </ul>	CHAIN OF ECM-IMMU [P1612]	PROCEDURE 1 (BL-113)	In rare case, "CHAIN OF ECM-IMMU" might be stored during key registration procedure, even if the system is not malfunctioning.	—
			Open circuit in battery voltage line of BCM circuit	C1
			Open circuit in ignition line of BCM circuit	C2
			Open circuit in ground line of BCM circuit	C3
			Open or short circuit between BCM and ECM communication line	C4
			ECM	B
			BCM	A
	DIFFERENCE OF KEY [P1615]	PROCEDURE 2 (BL-114)	Unregistered key	D
			BCM	A
	CHAIN OF IMMU-KEY [P1614]	PROCEDURE 5 (BL-117)	Malfunction of key ID chip	E5
			Communication line between ANT/ AMP and BCM:	E1
			Open circuit or short circuit of battery voltage line or ground line	E2
			Open circuit in power source line of ANT/ AMP circuit	E3
			Open circuit in ground line of ANT/ AMP circuit	E4
			NATS antenna amp.	E6
			BCM	A
	ID DISCORD, IMM-ECM [P1611]	PROCEDURE 3 (BL-115)	System initialization has not yet been completed.	F
ECM			B	
LOCK MODE [P1610]	PROCEDURE 4 (BL-116)	LOCK MODE	D	
Security indicator lighting up*	DON'T ERASE BEFORE CHECKING ENG DIAG	WORK FLOW (BL-110)	Engine trouble data and NVIS (NATS) trouble data have been detected in ECM	—

\*: When NVIS (NATS) detects trouble, the security indicator lights up while ignition key is in the "ON" position.

# NVIS(NISSAN VEHICLE IMMOBILIZER SYSTEM-NATS)

## SYMPTOM MATRIX CHART 2

### Non self-diagnosis related item

Symptom	Diagnostic Procedure (Reference page)	System (Malfunctioning part or mode)	Reference Part No. Of Illustration On System Diagram
Security indicator does not light up*.	PROCEDURE 6 (BL-120)	Combination meter (security indicator lamp)	—
		Open circuit between Fuse and BCM	—
		BCM	A

\*: CONSULT-II self-diagnostic results display screen "no malfunction is detected".

## DIAGNOSTIC SYSTEM DIAGRAM

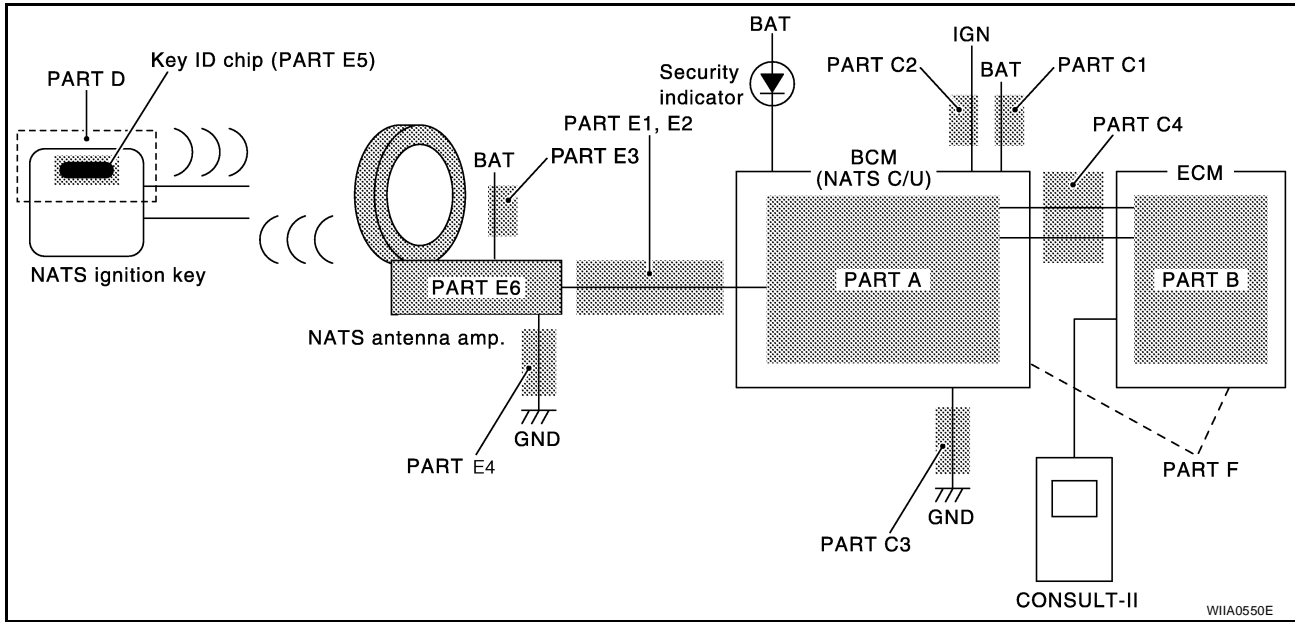



# NVIS(NISSAN VEHICLE IMMOBILIZER SYSTEM-NATS)

E/S006DI

## Diagnostic Procedure 1

Self-diagnostic results:

“CHAIN OF ECM-IMMU” displayed on CONSULT-II screen

First perform the “SELF-DIAG RESULTS” in “BCM” with CONSULT-II, then perform the trouble diagnosis of malfunction system indicated “SELF-DIAG RESULTS” of “BCM”. Refer to [BL-107, "CONSULT-II"](#)

### 1. CONFIRM SELF-DIAGNOSTIC RESULTS

Confirm SELF-DIAGNOSTIC RESULTS “CHAIN OF ECM-IMMU” displayed on CONSULT-II screen.

**NOTE:**

In rare case, “CHAIN OF ECM-IMMU” might be stored during key registration procedure, even if the system is not malfunctioning.

Is CONSULT-II screen displayed as above?

Yes >> GO TO 2.

No >> GO TO [BL-111, "SYMPTOM MATRIX CHART 1"](#).

SELF DIAGNOSIS	
DTC RESULTS	TIME
CHAIN OF ECM-IMMU [P1612]	0

PIIA1260E

### 2. CHECK POWER SUPPLY CIRCUIT FOR BCM

- Turn ignition switch OFF.
- Check voltage between BCM connector M20 terminal 70 and ground.

**70 - Ground : Battery voltage**

OK or NG

OK >> GO TO 3.

NG >> Check the following.

- 50A fusible link (letter **g**, located in fuse and fusible link box)
  - Harness for open or short between fuse and BCM connector
- Ref. Part No. C1**

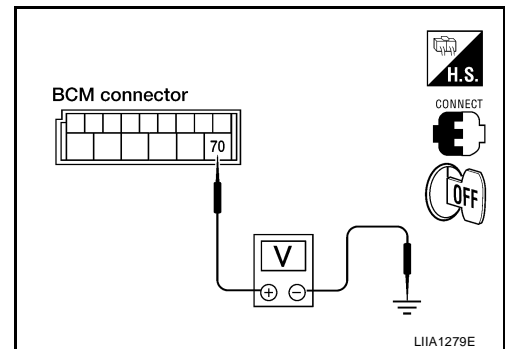

### 3. CHECK IGN SW. ON SIGNAL

- Turn ignition switch ON.
- Check voltage between BCM connector M18 terminal 38 and ground.

**38 - Ground : Battery voltage**

OK or NG

OK >> GO TO 4.

NG >> Check the following.

- 10A fuse [No. 1, located in the fuse block (J/B)]
  - Harness for open or short between fuse and BCM connector
- Ref. part No. C2**

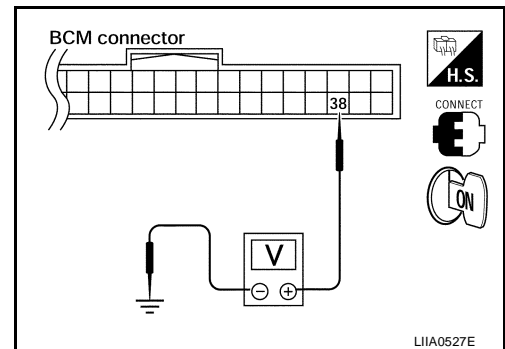

# NVIS(NISSAN VEHICLE IMMOBILIZER SYSTEM-NATS)

## 4. CHECK GROUND CIRCUIT FOR BCM

1. Turn ignition OFF.
2. Disconnect BCM.
3. Check continuity between BCM connector M20 terminal 67 and ground.

**67 - Ground :Continuity should exist.**

OK or NG

- OK >> GO TO 5.  
NG >> Repair or replace harness. **Ref. part No. C3**

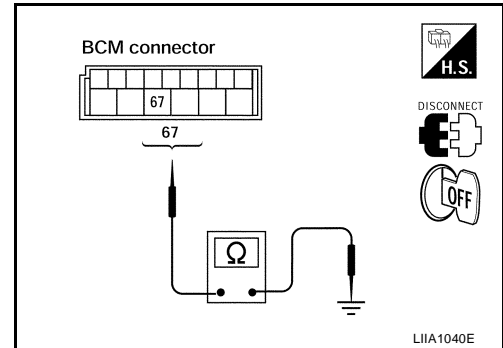

## 5. REPLACE BCM

1. Replace BCM. **Ref. part No. A**
2. Perform initialization with CONSULT-II.  
For initialization, refer to "CONSULT-II Operation Manual NATS-IVIS/NVIS".

Does the engine start?

- Yes >> BCM is malfunctioning.  
No >> ECM is malfunctioning.
- Replace ECM. **Ref. part No. B**
  - Perform initialization or re-communicating function.
  - For initialization, refer to "CONSULT-II Operation Manual NATS-IVIS/NVIS".
  - For re-communicating function, refer to [BL-104, "ECM Re-communicating Function"](#) .

## Diagnostic Procedure 2

EIS006DJ

**Self-diagnostic results:**

"DIFFERENCE OF KEY" displayed on CONSULT-II screen

### 1. CONFIRM SELF-DIAGNOSTIC RESULTS

Confirm SELF-DIAGNOSTIC RESULTS "DIFFERENCE OF KEY" displayed on CONSULT-II screen.

Is CONSULT-II screen displayed as above?

- Yes >> GO TO 2.  
No >> GO TO [BL-111, "SYMPTOM MATRIX CHART 1"](#) .

SELF DIAG RESULTS	
DTC RESULTS	TIME
DIFFERENCE OF KEY [P1615]	0

PIIA1261E

# NVIS(NISSAN VEHICLE IMMOBILIZER SYSTEM-NATS)

## 2. PERFORM INITIALIZATION WITH CONSULT-II

Perform initialization with CONSULT-II. Re-register all NATS ignition key IDs.  
For initialization and registration of NATS ignition key IDs, refer to "CONSULT-II Operation Manual NATS-IVIS/NVIS".

### NOTE:

If the initialization is not completed or malfunctions, CONSULT-II shows message on the screen.

Can the system be initialized and can the engine be started with re-registered NATS ignition key?

- Yes >> Ignition key ID was unregistered. **Ref. part No. D**  
No >> BCM is malfunctioning.
- Replace BCM. **Ref. part No. A**
  - Perform initialization with CONSULT-II.
  - For initialization, refer to "CONSULT-II Operation Manual NATS-IVIS/NVIS".

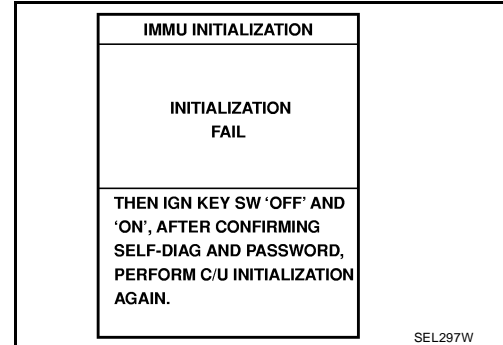

## Diagnostic Procedure 3

EIS006DK

### Self-diagnostic results:

"ID DISCORD, IMM-ECM" displayed on CONSULT-II screen

## 1. CONFIRM SELF-DIAGNOSTIC RESULTS

Confirm SELF-DIAGNOSTIC RESULTS "ID DISCORD, IMM-ECM" displayed on CONSULT-II screen.

### NOTE:

"ID DISCORD IMM-ECM":

Registered ID of BCM is in discord with that of ECM.

Is CONSULT-II screen displayed as above?

- Yes >> GO TO 2.  
No >> GO TO [BL-111, "SYMPTOM MATRIX CHART 1"](#).

SELF DIAG RESULTS	
DTC RESULTS	TIME
ID DISCORD, IMM-ECM [P1611]	0

The reference code "PIIA1262E" is in the bottom right corner.

## 2. PERFORM INITIALIZATION WITH CONSULT-II

Perform initialization with CONSULT-II. Re-register all NATS ignition key IDs.

For initialization, refer to "CONSULT-II Operation Manual NATS-IVIS/NVIS".

### NOTE:

If the initialization is not completed or malfunctions, CONSULT-II shows message on the screen.

Can the system be initialized?

- Yes >> ● Start engine. (END)  
● (System initialization had not been completed. **Ref. part No. F**)
- No >> ECM is malfunctioning.
- Replace ECM. **Ref. part No. B**
  - Perform initialization with CONSULT-II.  
For initialization, refer to "CONSULT-II Operation Manual NATS-IVIS/NVIS".

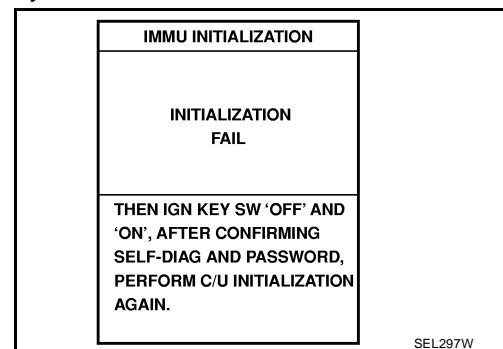

# NVIS(NISSAN VEHICLE IMMOBILIZER SYSTEM-NATS)

EIS006DL

## Diagnostic Procedure 4

### Self-diagnostic results:

“LOCK MODE” displayed on CONSULT-II screen

### 1. CONFIRM SELF-DIAGNOSTIC RESULTS

Confirm SELF-DIAGNOSTIC RESULTS “LOCK MODE” is displayed on CONSULT-II screen.

Is CONSULT-II screen displayed as above?

Yes >> GO TO 2.

No >> GO TO [BL-111, "SYMPTOM MATRIX CHART 1"](#).

SELF DIAG RESULTS	
DTC RESULTS	TIME
LOCK MODE [P1610]	0

PIA1264E

### 2. ESCAPE FROM LOCK MODE

1. Turn ignition switch OFF.
2. Turn ignition switch ON with registered key. (Do not start engine.) Wait 5 seconds.
3. Return the key to OFF position. Wait 5 seconds.
4. Repeat steps 2 and 3 twice (total of three cycles).
5. Start the engine.

Does engine start?

Yes >> System is OK (Now system is escaped from “LOCK MODE”). Clear all codes.

No >> GO TO 3.

### 3. PERFORM INITIALIZATION WITH CONSULT-II

Perform initialization with CONSULT-II.

For initialization, refer to “CONSULT-II Operation Manual NATS-IVIS/NVIS”.

#### NOTE:

If the initialization is not completed or malfunctions, CONSULT-II shows the message on the screen.

Can the system be initialized?

Yes >> System is OK.

No >> GO TO 4.

IMMU INITIALIZATION
INITIALIZATION FAIL
THEN IGN KEY SW 'OFF' AND 'ON', AFTER CONFIRMING SELF-DIAG AND PASSWORD, PERFORM C/U INITIALIZATION AGAIN.

SEL297W

# NVIS(NISSAN VEHICLE IMMOBILIZER SYSTEM-NATS)

## 4. PERFORM INITIALIZATION WITH CONSULT-II AGAIN

1. Replace BCM.
2. Perform initialization with CONSULT-II.  
For initialization, refer to "CONSULT-II Operation Manual NATS-IVIS/NVIS".

### NOTE:

If the initialization is not completed or malfunctions, CONSULT-II shows the message on the screen.

Can the system be initialized?

- Yes >> System is OK. BCM is malfunctioning. **Ref. part No. A**  
No >> ECM is malfunctioning.

- Replace ECM. **Ref. part No. B**
- Perform initialization with CONSULT-II.  
For initialization, refer to "CONSULT-II Operation Manual NATS-IVIS/NVIS".

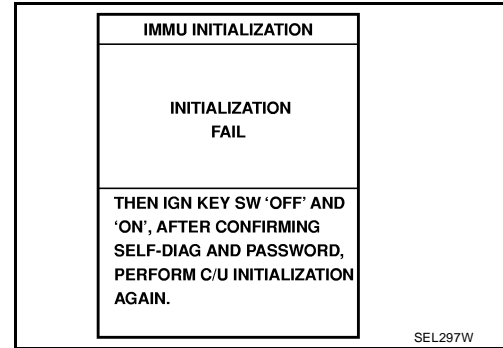

## Diagnostic Procedure 5

EIS006DM

### Self-diagnostic results:

"CHAIN OF IMMU-KEY" displayed on CONSULT-II screen

### 1. CONFIRM SELF-DIAGNOSTIC RESULTS

Confirm SELF-DIAGNOSTIC RESULTS "CHAIN OF IMMU-KEY" displayed on CONSULT-II screen.

Is CONSULT-II screen displayed as above?

- Yes >> GO TO 2.  
No >> GO TO [BL-111, "SYMPTOM MATRIX CHART 1"](#) .

SELF DIAGNOSIS	
DTC RESULTS	TIME
CHAIN OF IMMU-KEY [P1614]	0

PIIA1263E

## 2. CHECK NATS ANTENNA AMP. INSTALLATION

Check NATS antenna amp. installation. Refer to [BL-121, "How to Replace NATS Antenna Amp."](#) .

OK or NG

- OK >> GO TO 3.  
NG >> Reinstall NATS antenna amp. correctly.

## 3. CHECK NVIS (NATS) IGNITION KEY ID CHIP

Start engine with another registered NATS ignition key.

Does the engine start?

- Yes >> Ignition key ID chip is malfunctioning.
- Replace the ignition key.  
**Ref. part No. E5**
  - Perform initialization with CONSULT-II.  
For initialization, refer to "CONSULT-II Operation Manual NATS-IVIS/NVIS".
- No >> GO TO 4.

# NVIS(NISSAN VEHICLE IMMOBILIZER SYSTEM-NATS)

## 4. CHECK POWER SUPPLY FOR NATS ANTENNA AMP.

1. Turn ignition switch OFF.
2. Check voltage between NATS antenna amp. connector M21 terminal 1 and ground.

**1 - Ground : Battery voltage**

OK or NG

- OK >> GO TO 5.  
 NG >> Repair or replace fuse or harness. **Ref. part No. E3**

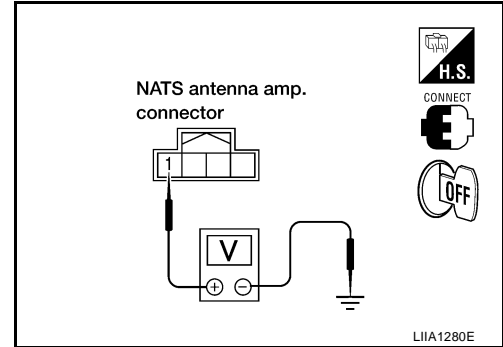

## 5. CHECK NATS ANTENNA AMP. SIGNAL LINE- 1

Check voltage between NATS antenna amp. connector M21 terminal 2 and ground with analog tester.

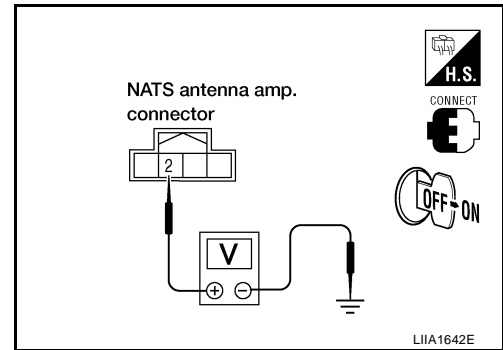

<b>2 - Ground</b>	<b>Before inserting key into ignition key cylinder</b>	<b>: Battery voltage</b>
	<b>After inserting key into ignition key cylinder</b>	<b>: Pointer of tester should move for 30 seconds, then return to battery voltage.</b>
	<b>Just after turning ignition switch ON</b>	<b>: Pointer of tester should move for approx. 1 second, then return to battery voltage.</b>

OK or NG

- OK >> GO TO 6.  
 NG >> ● Repair or replace harness. **Ref. part No. E1**

**NOTE:**

If harness is OK, replace BCM, perform initialization with CONSULT-II. For initialization, refer to "CONSULT-II Operation Manual NATS-IVIS/NVIS".

# NVIS(NISSAN VEHICLE IMMOBILIZER SYSTEM-NATS)

## 6. CHECK NATS ANTENNA AMP. SIGNAL LINE- 2

Check voltage between NATS antenna amp. connector M21 terminal 4 and ground with analog tester.

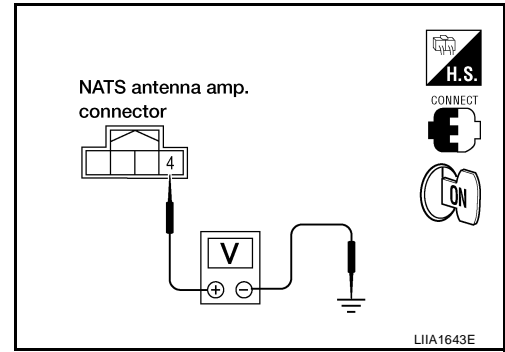

	Before inserting key into ignition key cylinder	: Battery voltage
4 - Ground	After inserting key into ignition key cylinder	: Pointer of tester should move for 30 seconds, then return to battery voltage.
	Just after turning ignition switch ON	: Pointer of tester should move for approx. 1 second, then return to battery voltage.

OK or NG

- OK >> GO TO 7.
- NG >> ● Repair or replace harness. **Ref. part No. E2**

**NOTE:**

If harness is OK, replace BCM, perform initialization with CONSULT-II. For initialization, refer to "CONSULT-II Operation Manual NATS-IVIS/NVIS".

## 7. CHECK NATS ANTENNA AMP. GROUND LINE CIRCUIT

1. Turn ignition switch OFF.
2. Check continuity between NATS antenna amp. connector M21 terminal 3 and ground.

**3 - Ground : Continuity should exist.**

OK or NG

- OK >> NATS antenna amp. is malfunctioning. **Ref. part No. E6**
- NG >> ● Repair or replace harness. **Ref. part No. E4**

**NOTE:**

If harness is OK, replace BCM, perform initialization with CONSULT-II. For initialization, refer to "CONSULT-II Operation Manual NATS-IVIS/NVIS".

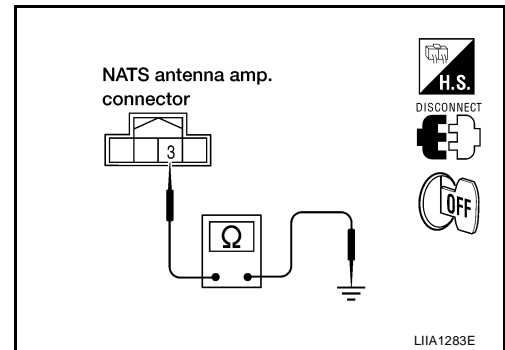

# NVIS(NISSAN VEHICLE IMMOBILIZER SYSTEM-NATS)

EIS006DN

## Diagnostic Procedure 6

“SECURITY INDICATOR LAMP DOES NOT LIGHT UP”

### 1. CHECK FUSE

Check 10A fuse [No.19, located in the fuse block (J/B)].

OK or NG

- OK >> GO TO 2.
- NG >> Replace fuse.

### 2. CHECK SECURITY INDICATOR LAMP

1. Install 10A fuse.
2. Start engine and turn ignition switch OFF.
3. Check the security indicator lamp lights up.

**Security indicator lamp should light up.**

OK or NG

- OK >> Inspection End.
- NG >> GO TO 3.

### 3. CHECK SECURITY INDICATOR LAMP POWER SUPPLY CIRCUIT

1. Disconnect combination meter.
2. Check voltage between combination meter connector M24 terminal 3 and ground.

**3 - Ground : Battery voltage**

OK or NG

- OK >> GO TO 4.
- NG >> Repair or replace harness.

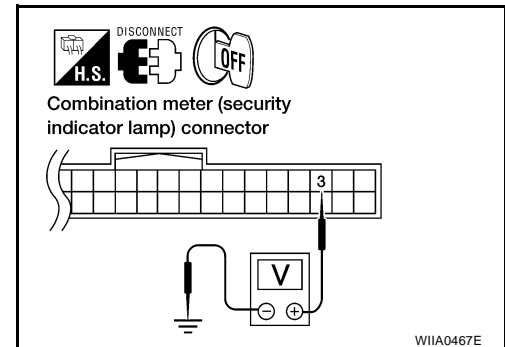

### 4. CHECK BCM (NATS CONTROL UNIT) FUNCTION

1. Connect combination meter.
2. Disconnect BCM.
3. Check voltage between BCM connector M18 terminal 23 and ground.

**23 - Ground : Battery voltage**

OK or NG

- OK >> BCM is malfunctioning.
  - Replace BCM.  
**Ref. part No. A**
  - Perform initialization with CONSULT-II.
  - For initialization, refer to “CONSULT-II Operation Manual NATS-IVIS/NVIS”.
- NG >> Check the following.
  - Harness for open or short between combination meter and BCM (NATS control unit).
  - Combination meter

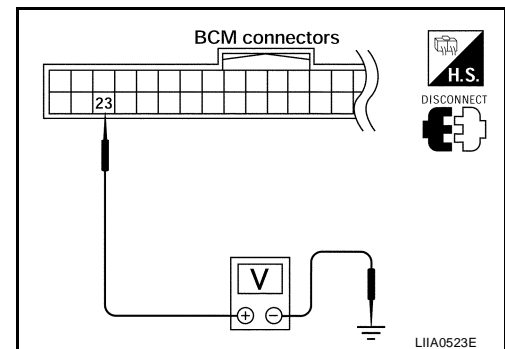



# NVIS(NISSAN VEHICLE IMMOBILIZER SYSTEM-NATS)

## How to Replace NATS Antenna Amp.

EIS006DO

### NOTE:

- If NATS antenna amp. is not installed correctly, NVIS (NATS) system will not operate properly and SELF-DIAG RESULTS on CONSULT-II screen will show "LOCK MODE" or "CHAIN OF IMMU-KEY".
- Initialization is not necessary when only NATS antenna amp. is replaced with a new one.

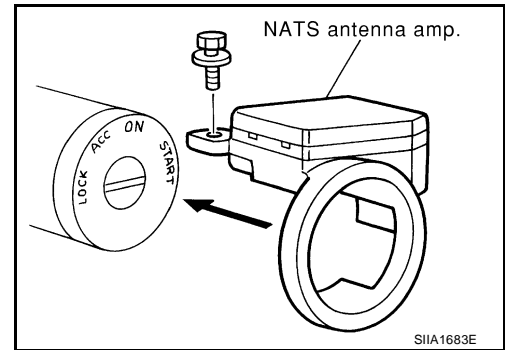

A  
B  
C  
D  
E  
F  
G  
H  
J  
K  
L  
M

BL

# CAB AND REAR BODY

PFP:93020

## CAB AND REAR BODY

EIS00662

### Body Mounting

- When removing, be sure to replace bolts and nuts (sealant applied bolts or self-lock nuts are used for all mounting).
- Unless otherwise noted, the bushings and insulators have paint marks that are to be installed facing outward.

SEC. 930

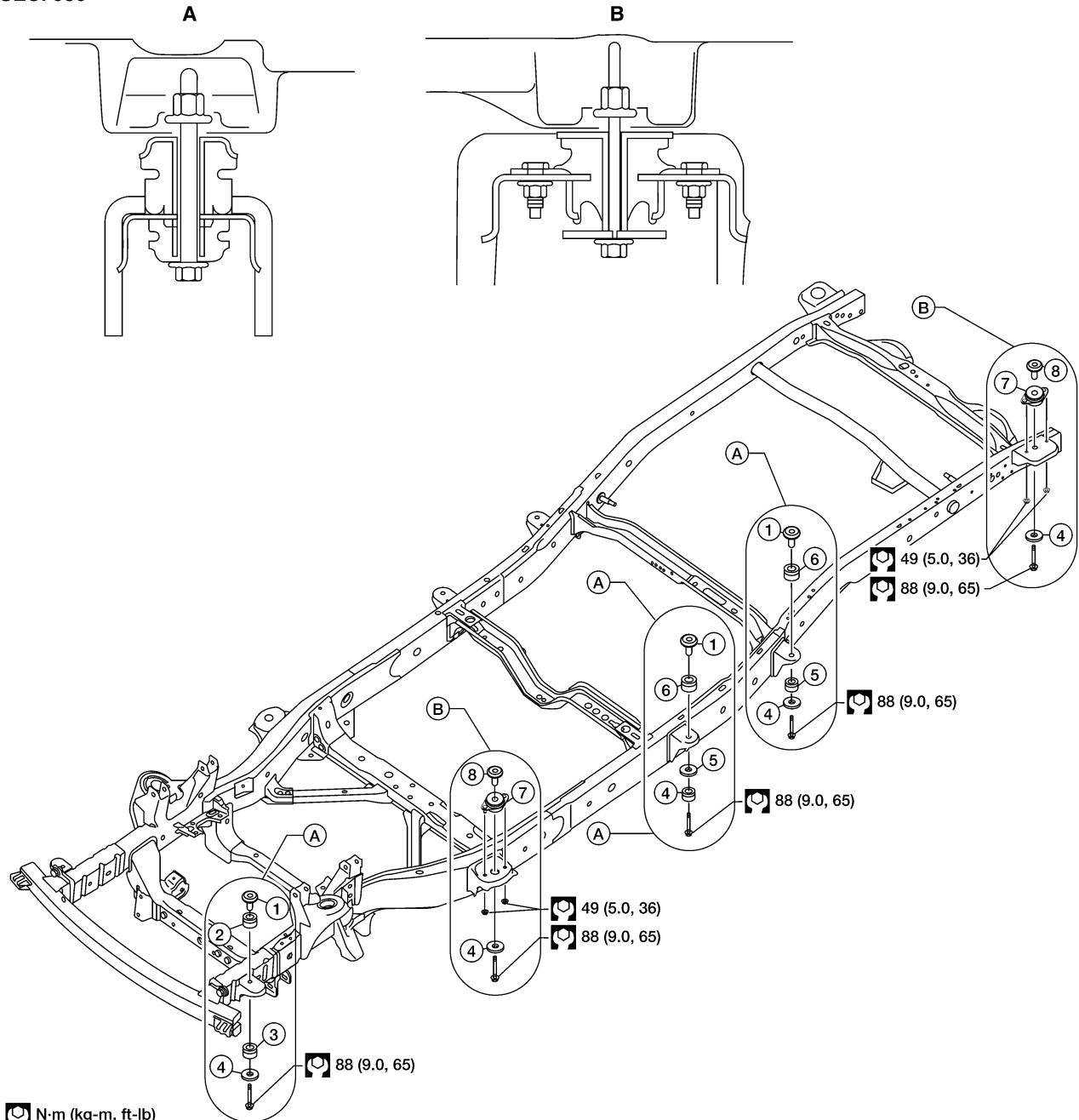

N-m (kg-m, ft-lb)

- |                         |                                     |                                     |
|-------------------------|-------------------------------------|-------------------------------------|
| 1. Gold washer          | 2. Upper bushing                    | 3. Lower bushing                    |
| 4. Black washer         | 5. Lower bushing without paint mark | 6. Upper bushing without paint mark |
| 7. Body mount insulator | 8. Body washer                      |                                     |

LIA2112E

# BODY REPAIR

## BODY REPAIR

PFP:60100

### Body Exterior Paint Color

E/S00663

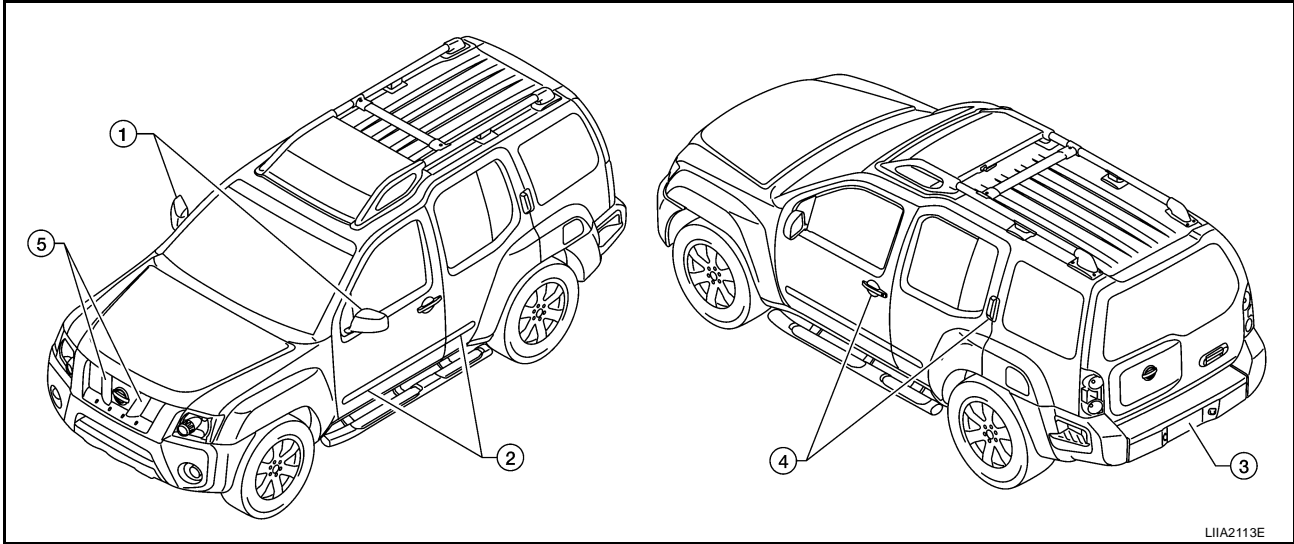

LIA2113E

Component			Color code	A15	BW9	EW3	K12	K26	KH3	KY2	QM1
			Description	Red Brawn	Midnight Blue	Solar Yellow	Silver Lightning	Night Armor	Super Black	Granite	Avalanche
			Paint type	2P	2PM	2S	2M	2M	2S	2M	2S
			Hard Clear coat	—	—	—	—	—	—	—	—
1	Outside mirror		Black	—	—	—	—	—	—	—	—
2	Side Guard Molding		Body color	A15	BW9	EW3	K12	K26	KH3	KY2	QM1
3	Rear Bumper		Black	—	—	—	—	—	—	—	—
4	Outside handles		Black	—	—	—	—	—	—	—	—
5	Radiator grille	Center and emblem	Chromium plate	Cr2P	Cr2P	Cr2P	Cr2P	Cr2P	Cr2P	Cr2P	Cr2P
		Center	Black	KH3	KH3	KH3	KH3	KH3	KH3	KH3	KH3

2M: Metallic with clear; 2S: 2-Coat Solid with clear, 2P: Pearl or Mica with clear; 2PM: Pearl - mica and metallic with clear

A  
B  
C  
D  
E  
F  
G  
H  
I  
J  
K  
L  
M

BL

# BODY REPAIR

## Body Component Parts UNDERBODY COMPONENT PARTS

EIS00664

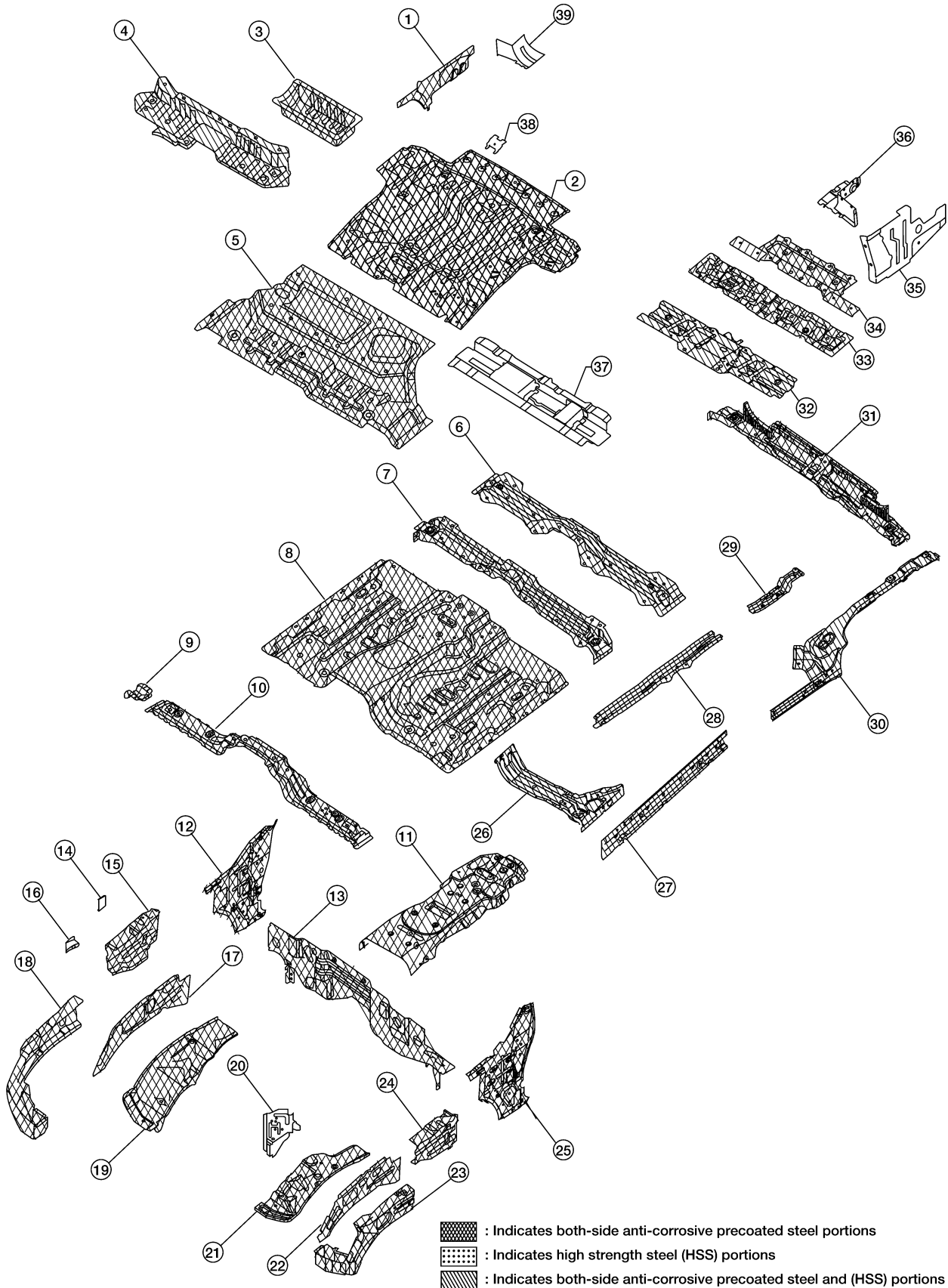

LIA2114E

# BODY REPAIR

---

1. Rear floor side RH	A
2. Rear floor rear	A
3. Storage bin	
4. Second seat mounting crossmember	
5. Rear floor front	B
6. Center pillar crossmember assembly	
7. Front seat mounting rear crossmember	C
8. Front floor	
9. Front seat mounting crossmember	
10. Second crossmember extension	D
11. Front floor reinforcement	
12. Side dash RH	
13. Lower dash	E
14. Washer tank bracket	
15. Hoodledge reinforcement rear RH	
16. Hoodledge plate	F
17. Hoodledge RH	
18. Hoodledge reinforcement assembly RH	
19. Rear lower hoodledge RH	G
20. Battery tray	
21. Rear lower hoodledge LH	H
22. Hoodledge LH	
23. Hoodledge reinforcement assembly LH	
24. Hoodledge reinforcement rear LH	BL
25. Side dash LH	
26. Second crossmember assembly (RH & LH)	
27. Inner sill (RH & LH)	J
28. Front side member assembly (RH & LH)	
29. Center floor member assembly	
30. Rear side member rear (RH & LH)	K
31. Rear crossmember	
32. Second seat mounting crossmember	L
33. Third seat mounting bracket assembly	
34. Rope hook bracket	
35. Rear floor side LH	M
36. Rear floor side upper extension assembly LH	
37. Third seat mounting rear crossmember assembly	
38. Trim mounting bracket	
39. Rear floor side upper extension assembly RH	

# BODY REPAIR

## BODY COMPONENT PARTS

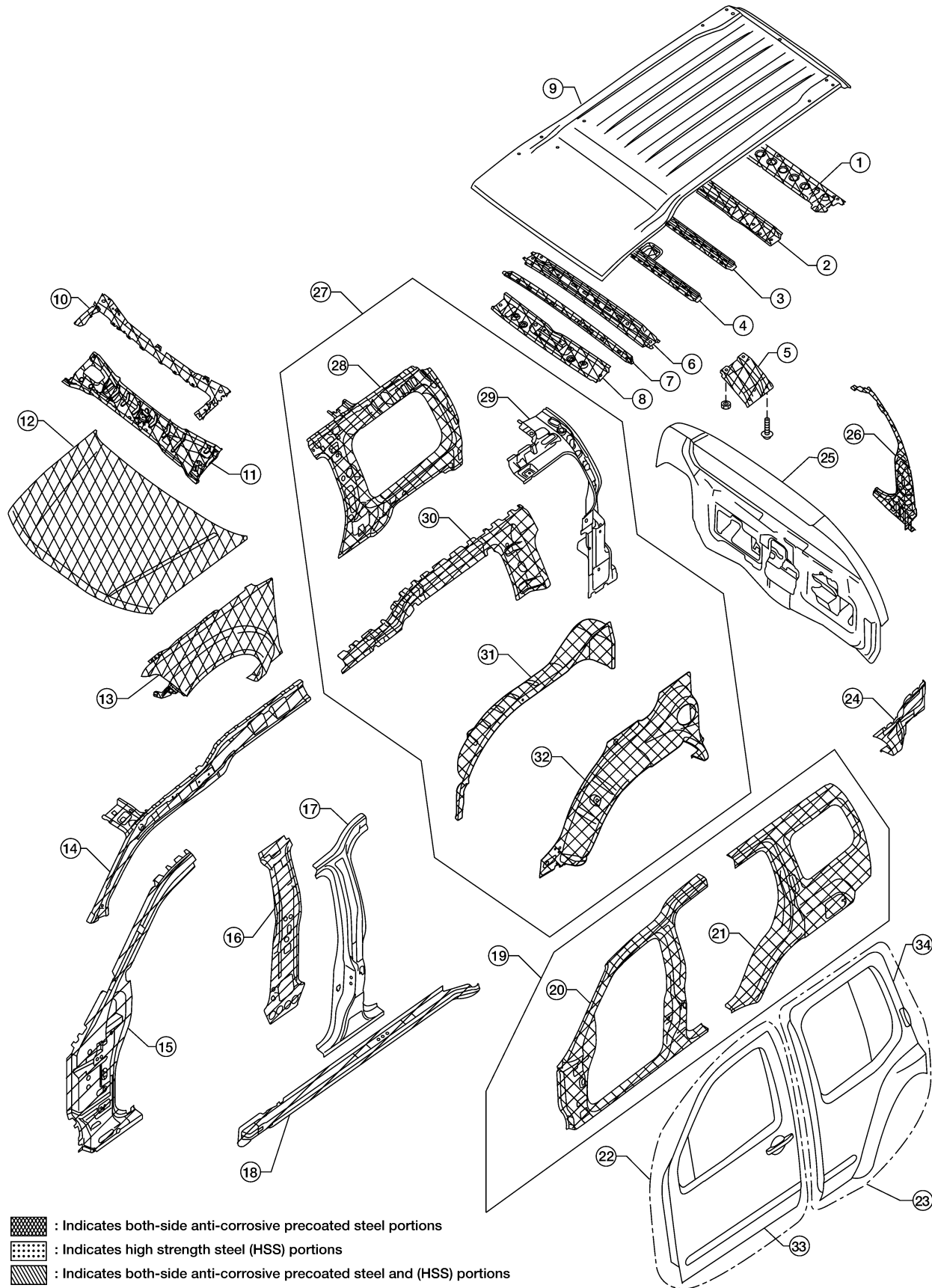

LIA2115E

# BODY REPAIR

---

1. Rear roof rail	A
2. Roof 5th bow	
3. Roof 4th bow	
4. Roof 3rd bow	
5. Roof bow second bracket	B
6. Roof 2nd bow	
7. Roof 1st bow	
8. Front roof rail	C
9. Roof	
10. Upper dash crossmember assembly	D
11. Upper dash assembly	
12. Hood assembly	
13. Front fender (RH & LH)	E
14. Front inner pillar upper (RH & LH)	
15. Front pillar hinge brace (RH & LH)	
16. Center inner pillar (RH & LH)	F
17. Center pillar hinge brace	
18. Outer sill reinforcement (RH & LH)	
19. Body side outer assembly	G
20. Front body side outer (RH & LH)	
21. Rear body side outer (RH & LH)	H
22. Front door assembly (RH & LH)	
23. Rear door assembly (RH & LH)	
24. Rear fender extension (RH & LH)	BL
25. Lift gate assembly	
26. Main back pillar (RH & LH)	
27. Body side inner reinforcement assembly (RH & LH)	J
28. Rear inner side panel (RH & LH)	
29. Back pillar reinforcement (RH & LH)	
30. Outer roof side rail reinforcement (RH & LH)	K
31. Rear wheel housing inner (RH & LH)	
32. Rear wheel housing outer (RH & LH)	L
33. Outer front door panel (RH & LH)	
34. Outer rear door panel (RH & LH)	M

# BODY REPAIR

## FRAME COMPONENT PARTS

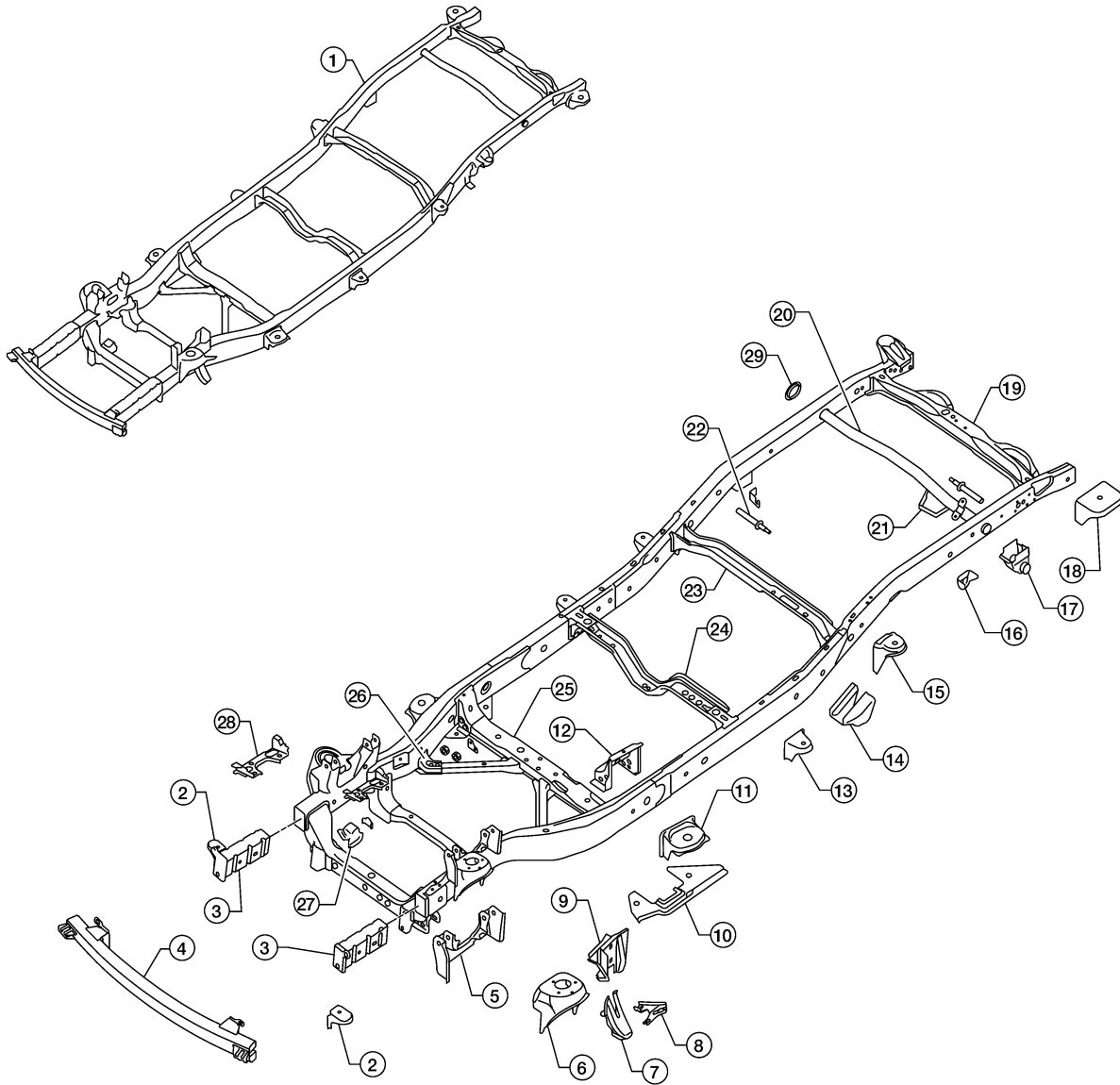

LIA2116E



## BODY REPAIR

---

1. Frame assembly	A
2. 1st cab mounting bracket (RH & LH)	
3. Front side member extension assembly (RH & LH)	
4. 1st crossmember assembly	B
5. Front upper link mounting bracket (RH & LH)	
6. Front shock absorber mounting bracket (RH & LH)	
7. Bound bumper bracket (RH & LH)	C
8. Front brake hose bracket (RH & LH)	
9. Panhard rod bracket reinforcement	
10. 4th crossmember gusset (RH & LH)	D
11. 2nd cab mounting bracket (RH & LH)	
12. 4th crossmember gusset (RH & LH)	
13. 3rd cab mounting bracket (RH & LH)	E
14. Rear suspension mounting bracket (RH & LH)	
15. 4th cab mounting bracket (RH & LH)	F
16. Rear bound bumper bracket (RH & LH)	
17. Rear suspension rear mounting bracket (RH & LH)	
18. Cab mounting bracket assembly (RH & LH)	G
19. 9th crossmember assembly	
20. Rear torsion crossmember	
21. Rear brake hose bracket	H
22. Rear shock pin (RH & LH)	
23. 6th crossmember assembly	
24. 5th crossmember assembly	BL
25. 4th crossmember assembly	
26. Crossmember support (RH & LH)	
27. Front differential mounting bracket (RH & LH)	J
28. Engine mount (RH & LH)	
29. Rear torsion crossmember collar (RH & LH)	K
	L
	M

# BODY REPAIR

EIS00665

## Corrosion Protection

### DESCRIPTION

To provide improved corrosion prevention, the following anti-corrosive measures have been implemented in NISSAN production plants. When repairing or replacing body panels, it is necessary to use the same anti-corrosive measures.

#### ANTI-CORROSIVE PRECOATED STEEL (GALVANNEALED STEEL)

To improve repairability and corrosion resistance, a new type of anti-corrosive precoated steel sheet has been adopted replacing conventional zinc-coated steel sheet.

Galvannealed steel is electroplated and heated to form Zinc-iron alloy, which provides excellent and long term corrosion resistance with cationic electrode position primer.

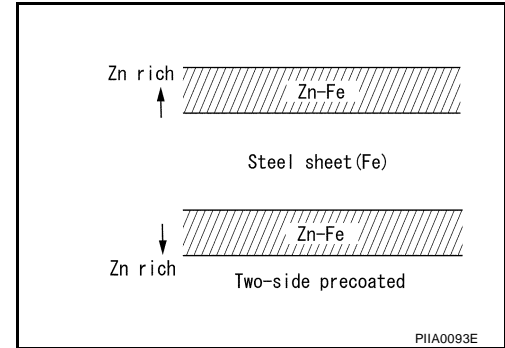

Nissan Genuine Service Parts are fabricated from galvannealed steel. Therefore, it is recommended that GENUINE NISSAN PARTS or equivalent be used for panel replacement to maintain the anti-corrosive performance built into the vehicle at the factory.

#### PHOSPHATE COATING TREATMENT AND CATIONIC ELECTRODEPOSITION PRIMER

A phosphate coating treatment and a cationic electrode position primer, which provide excellent corrosion protection, are employed on all body components.

#### CAUTION:

Confine paint removal during welding operations to an absolute minimum.

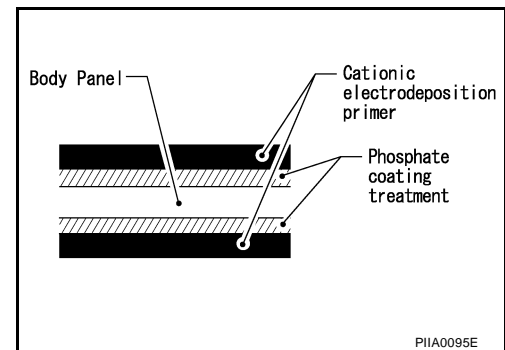



Nissan Genuine Service Parts are also treated in the same manner. Therefore, it is recommended that GENUINE NISSAN PARTS or equivalent be used for panel replacement to maintain anti-corrosive performance built into the vehicle at the factory.

# BODY REPAIR

## ANTI-CORROSIVE WAX

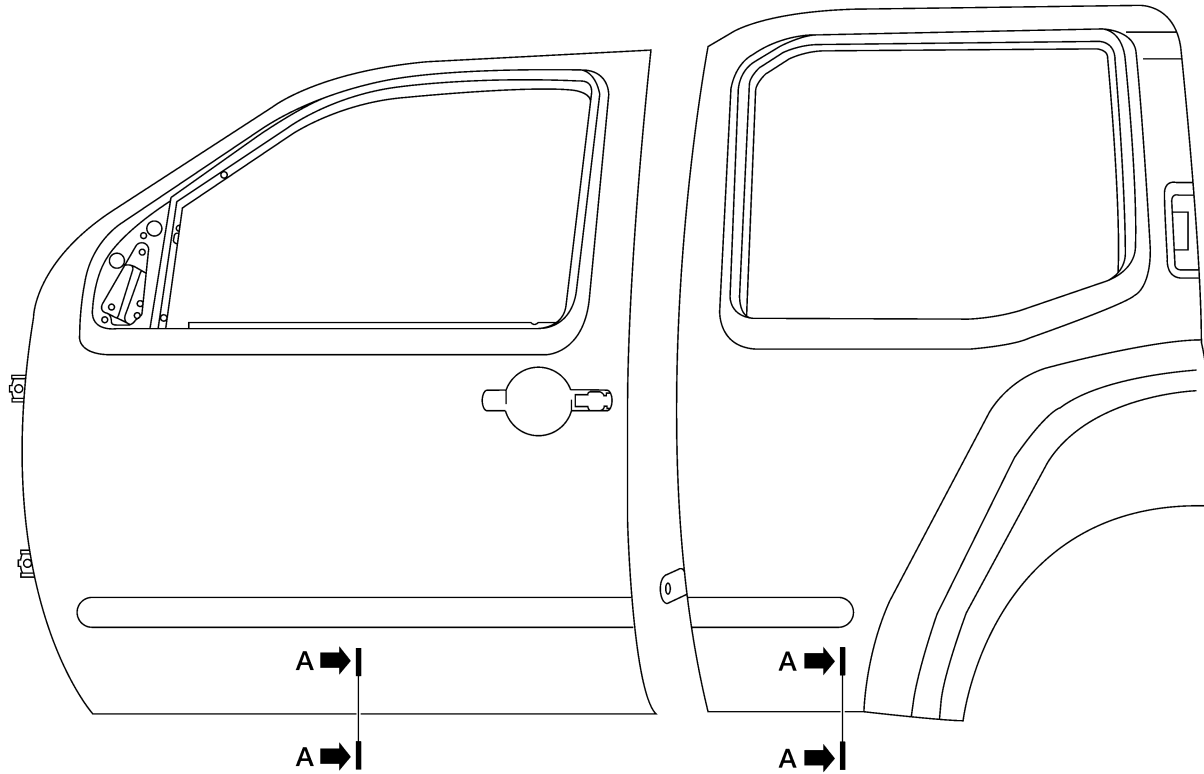
To improve corrosion resistance, anti-corrosive wax is applied inside the body sill and inside other closed sections. Accordingly, when replacing these parts, be sure to apply anti-corrosive wax to the appropriate areas of the new parts. Select an excellent anti-corrosive wax which will penetrate after application and has a long shelf life.



-  : Indicates outside body sealant
-  : Indicates anti-corrosive wax coated portions

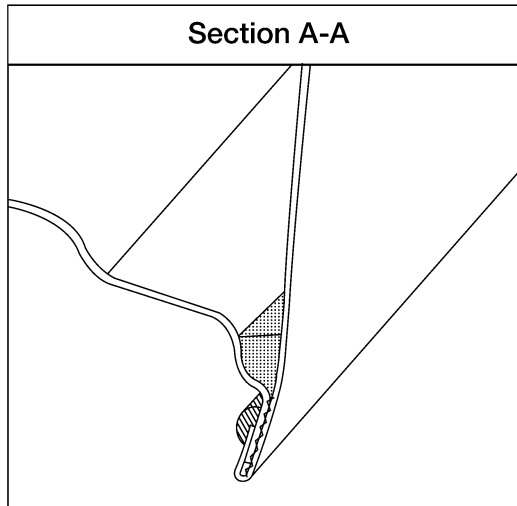

LIIA2062E

A  
B  
C  
D  
E  
F  
G  
H  
BL  
J  
K  
L  
M

# BODY REPAIR

## UNDERCOATING

The underside of the floor and wheelhouse are undercoated to prevent rust, vibration, noise and stone chipping. Therefore, when such a panel is replaced or repaired, apply undercoating to that part. Use an undercoating which is rust preventive, soundproof, vibration-proof, shock-resistant, adhesive, and durable.

### Precautions in undercoating

1. Do not apply undercoating to any place unless specified (such as the areas above the muffler and three way catalyst which are subjected to heat).
2. Do not undercoat the exhaust pipe or other parts which become hot.
3. Do not undercoat rotating parts.
4. Apply bitumen wax after applying undercoating.

 : Indicates undercoated portions.

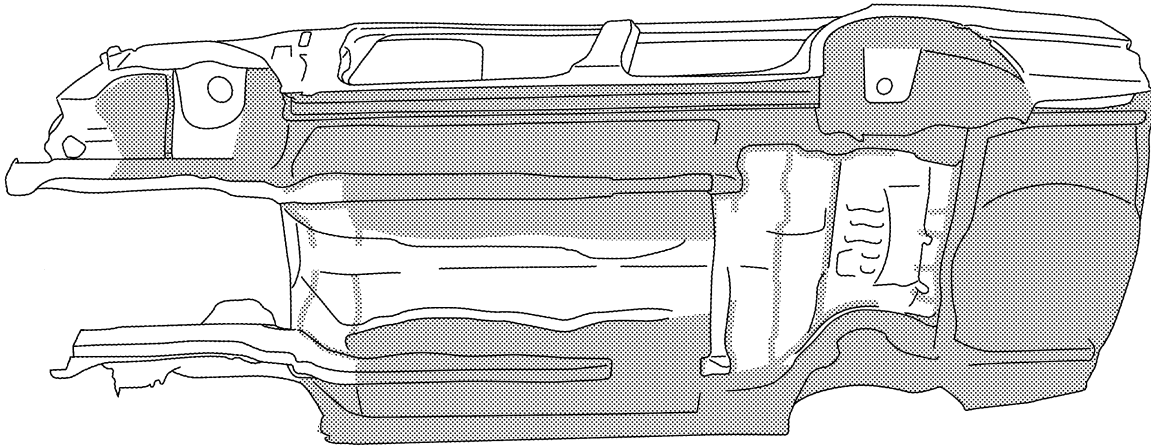

LIA0129E

# BODY REPAIR

EIS00666

## Body Sealing DESCRIPTION

The following figure shows the areas which are sealed at the factory. Sealant which has been applied to these areas should be smooth and free from cuts or gaps. Care should be taken not to apply an excess amount of sealant and not to allow other unaffected parts to come into contact with the sealant.

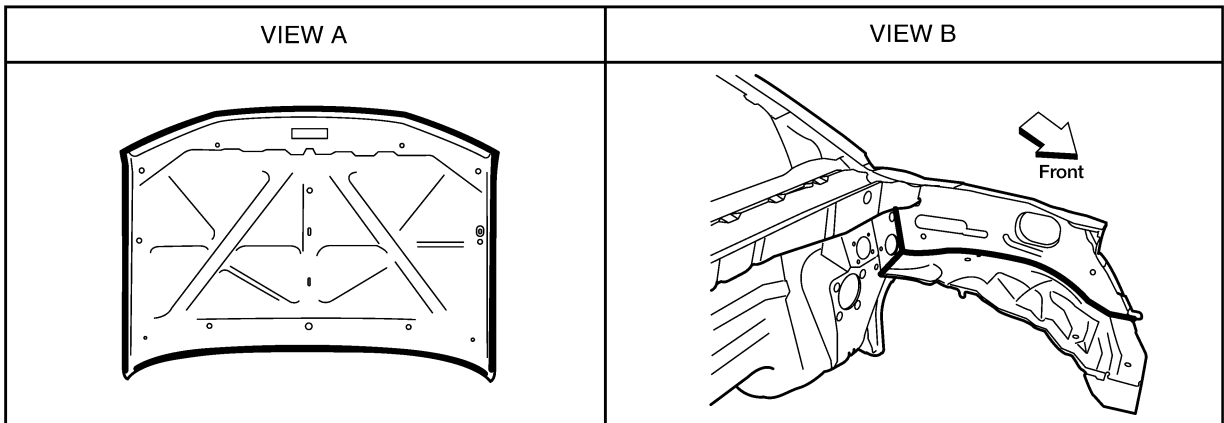
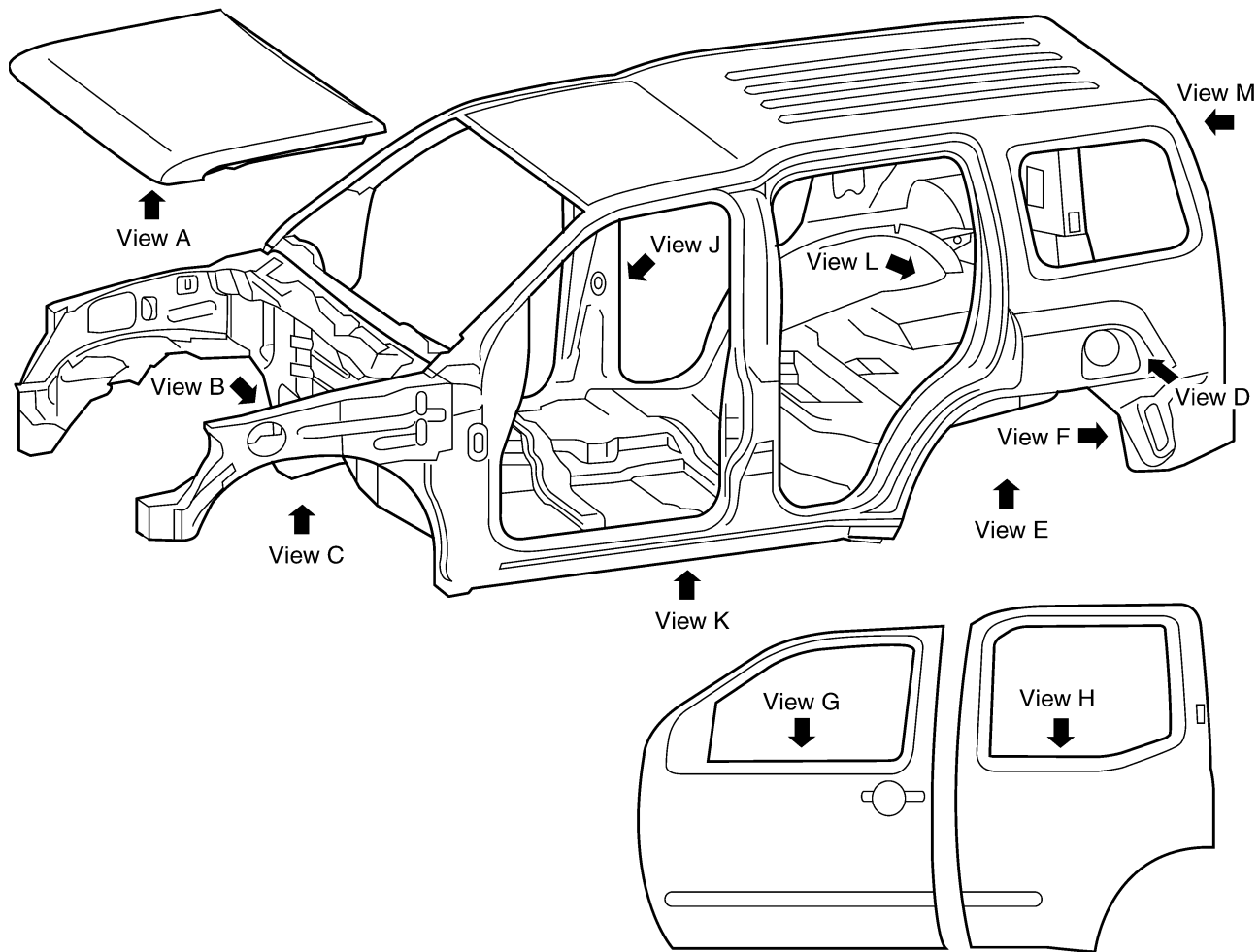

LIA2063E

A  
B  
C  
D  
E  
F  
G  
H  
BL  
J  
K  
L  
M

# BODY REPAIR

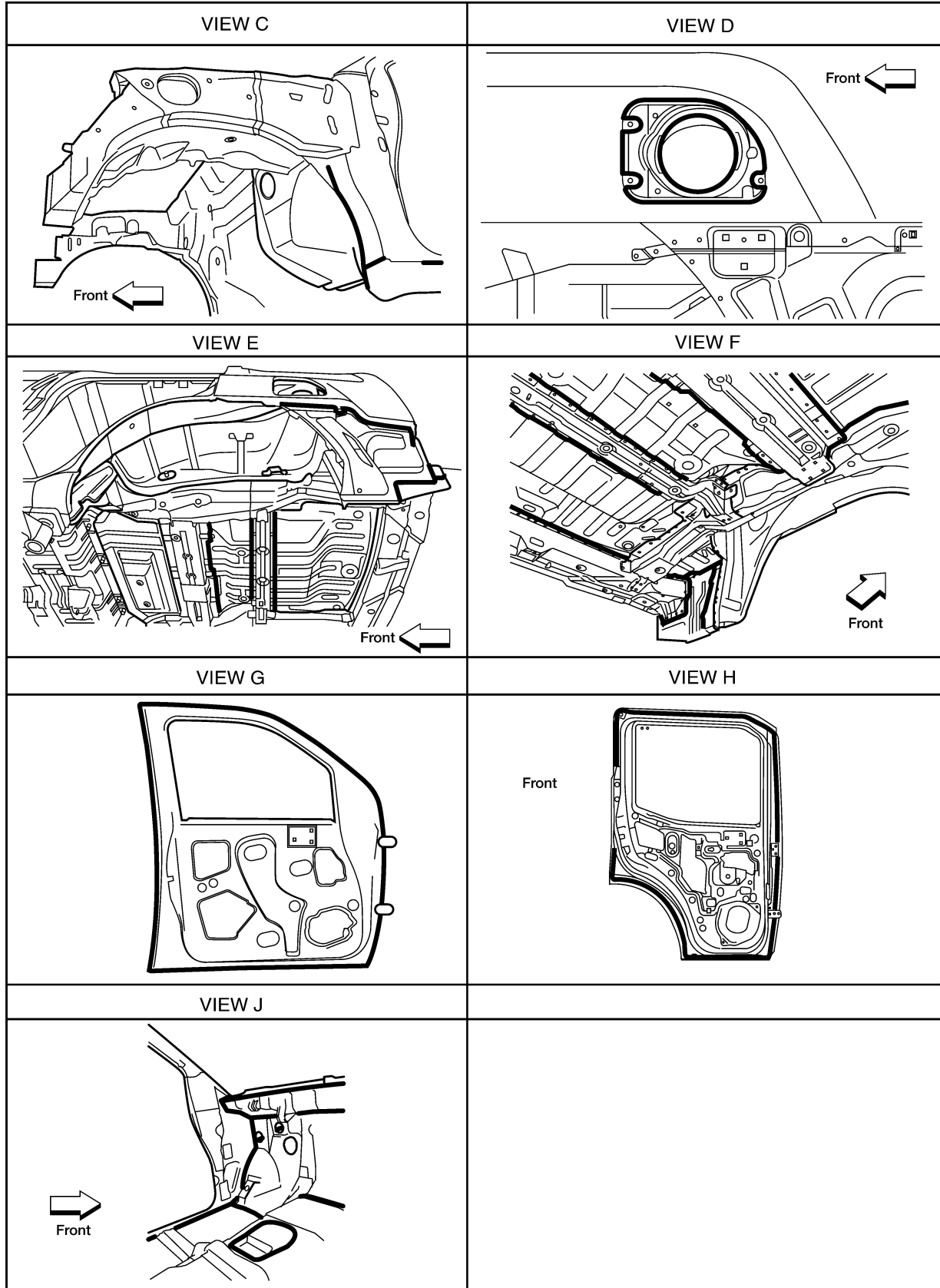

L1A2064E

# BODY REPAIR

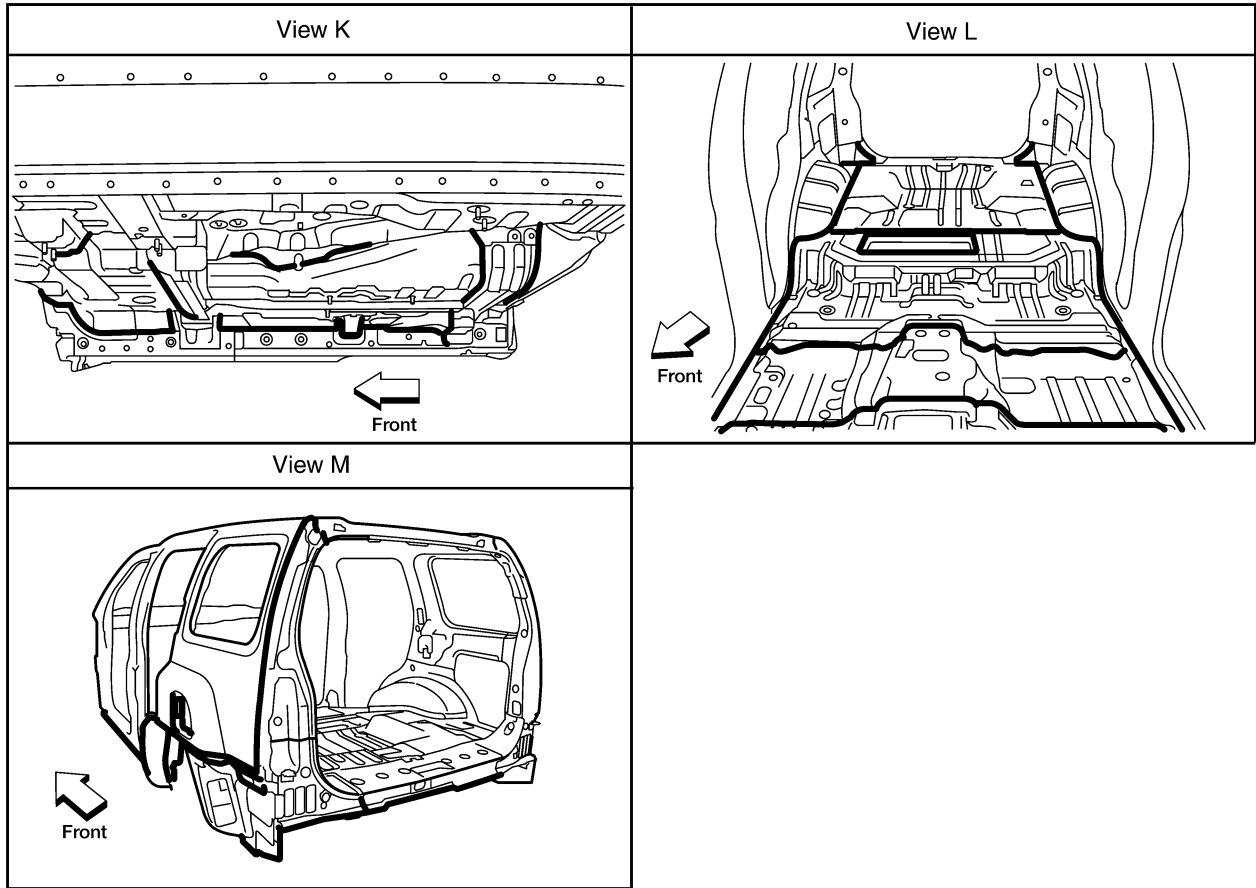

A  
B  
C  
D  
E  
F  
G  
H  
BL  
J  
K  
L  
M

LIA2065E

# BODY REPAIR

## Body Construction BODY CONSTRUCTION

EIS00667

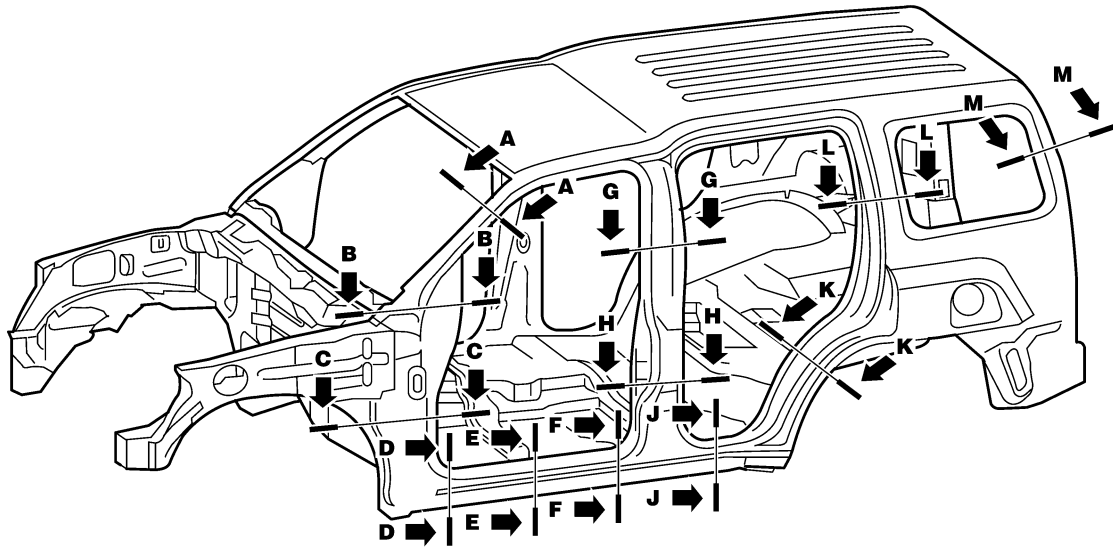

Section A-A	Section B-B	Section C-C	Section D-D

LIA2142E



# BODY REPAIR

## Body Alignment BODY CENTER MARKS

EIS00668

A mark has been placed on each part of the body to indicate the vehicle center. When repairing parts damaged by an accident which might affect the vehicle frame (members, pillars, etc.), more accurate and effective repair will be possible by using these marks together with body alignment specifications.

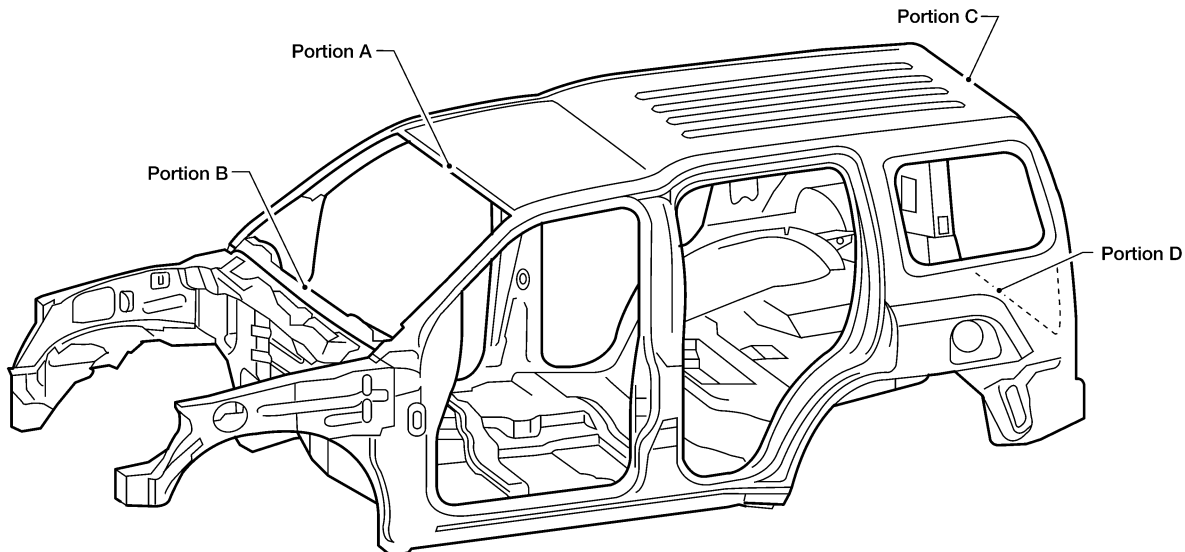

Portion A	Portion B	Portion C
<p>Embossment</p>	<p>Flange end</p>	<p>Notch</p>
<p>Flange end</p>		

LIA2066E

# BODY REPAIR

## PANEL PARTS MATCHING MARKS

A mark has been placed on each body panel to indicate the parts matching positions. When repairing parts damaged by an accident which might affect the vehicle structure (members, pillars, etc.), more accurate and effective repair will be possible by using these marks together with body alignment specifications.

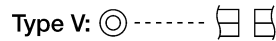
Type V: 

Type W: 

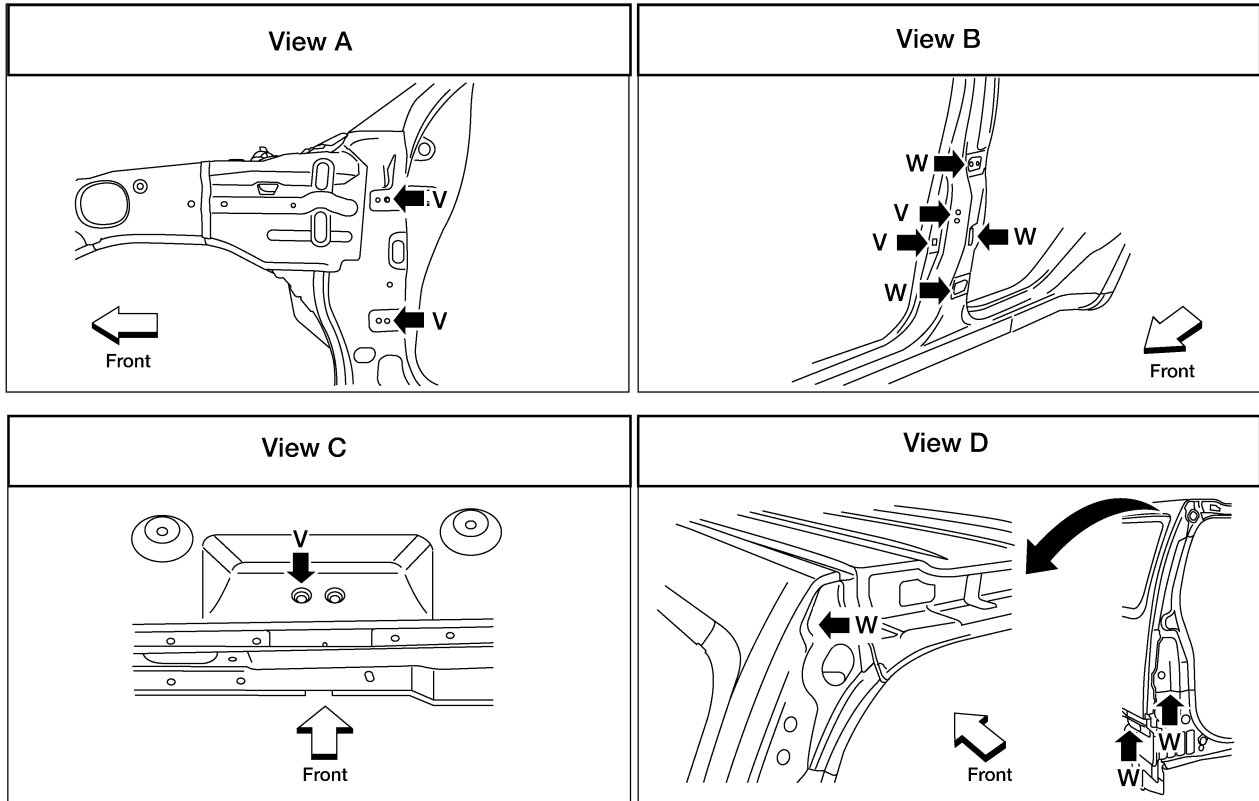
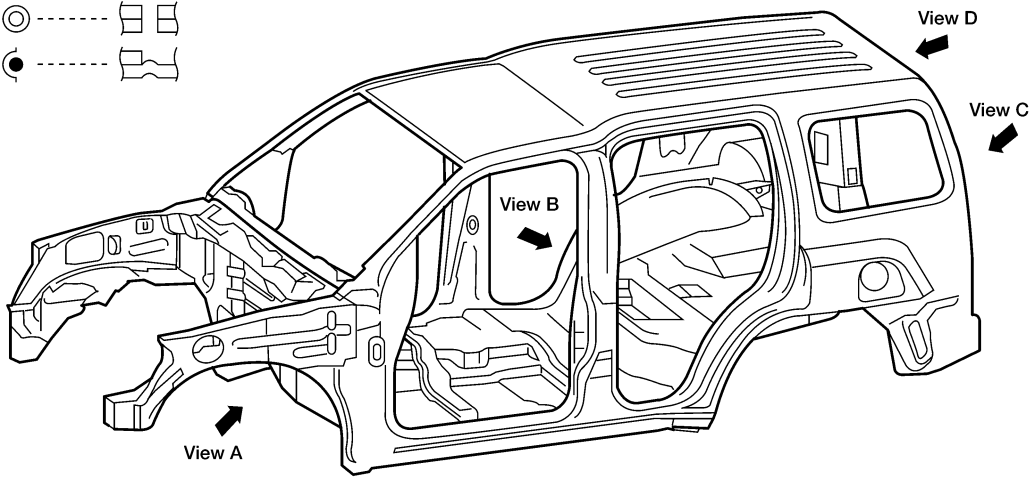

L1IA2067E

# BODY REPAIR

## DESCRIPTION

- All dimensions indicated in the figures are actual.
- When using a tracking gauge, adjust both pointers to equal length. Then check the pointers and gauge itself to make sure there is no free play.
- When a measuring tape is used, check to be sure there is no elongation, twisting or bending.
- Measurements should be taken at the center of the mounting holes.
- An asterisk (\*) following the value at the measuring point indicates that the measuring point on the other side is symmetrically the same value.
- The coordinates of the measurement points are the distances measured from the standard line of "X", "Y" and "Z".

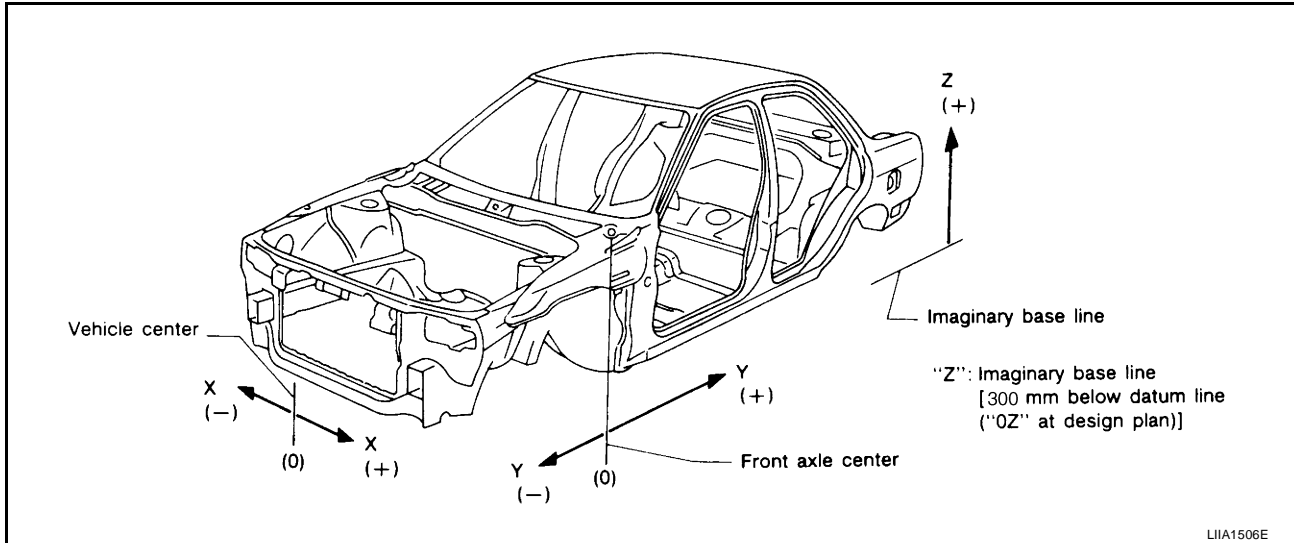

A  
B  
C  
D  
E  
F  
G  
H  
J  
K  
L  
M

BL

# BODY REPAIR

## ENGINE COMPARTMENT MEASUREMENT

All dimensions indicated in this figure are actual.

Figures marked with an (\*) indicate symmetrically identical dimensions on both right and left hand sides of the vehicle.

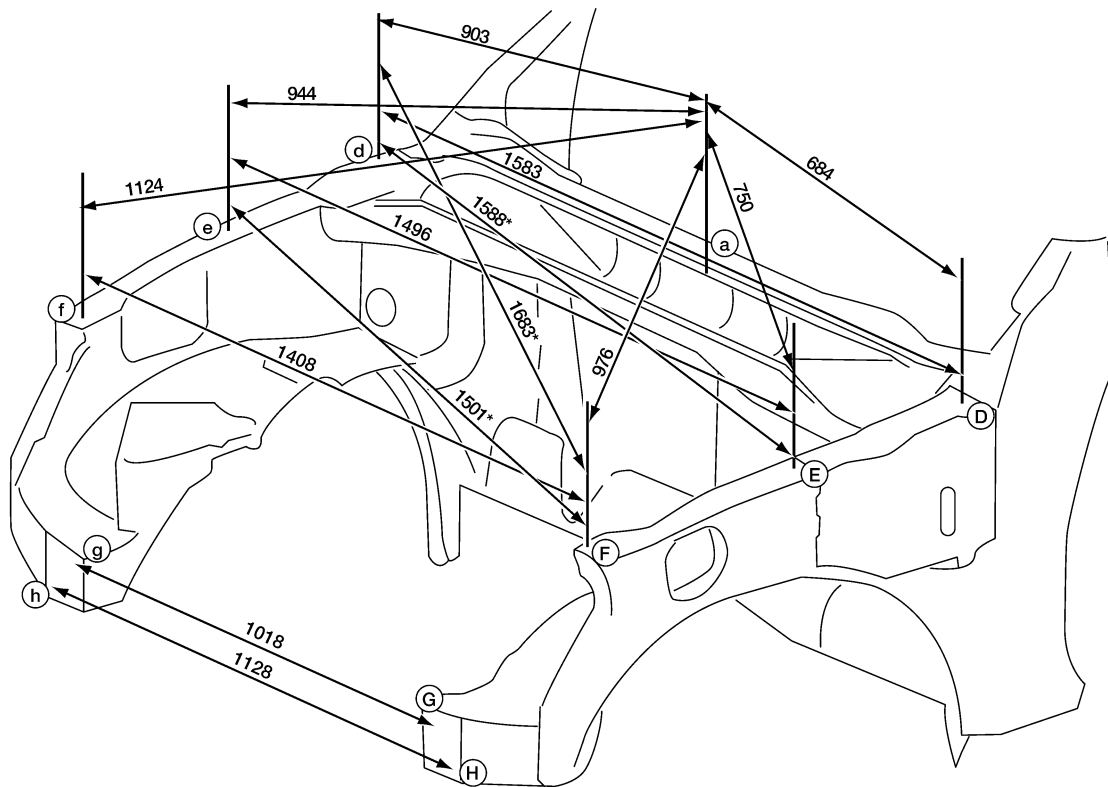

Unit: mm

L1IA2068E

# BODY REPAIR

## MEASUREMENT POINTS

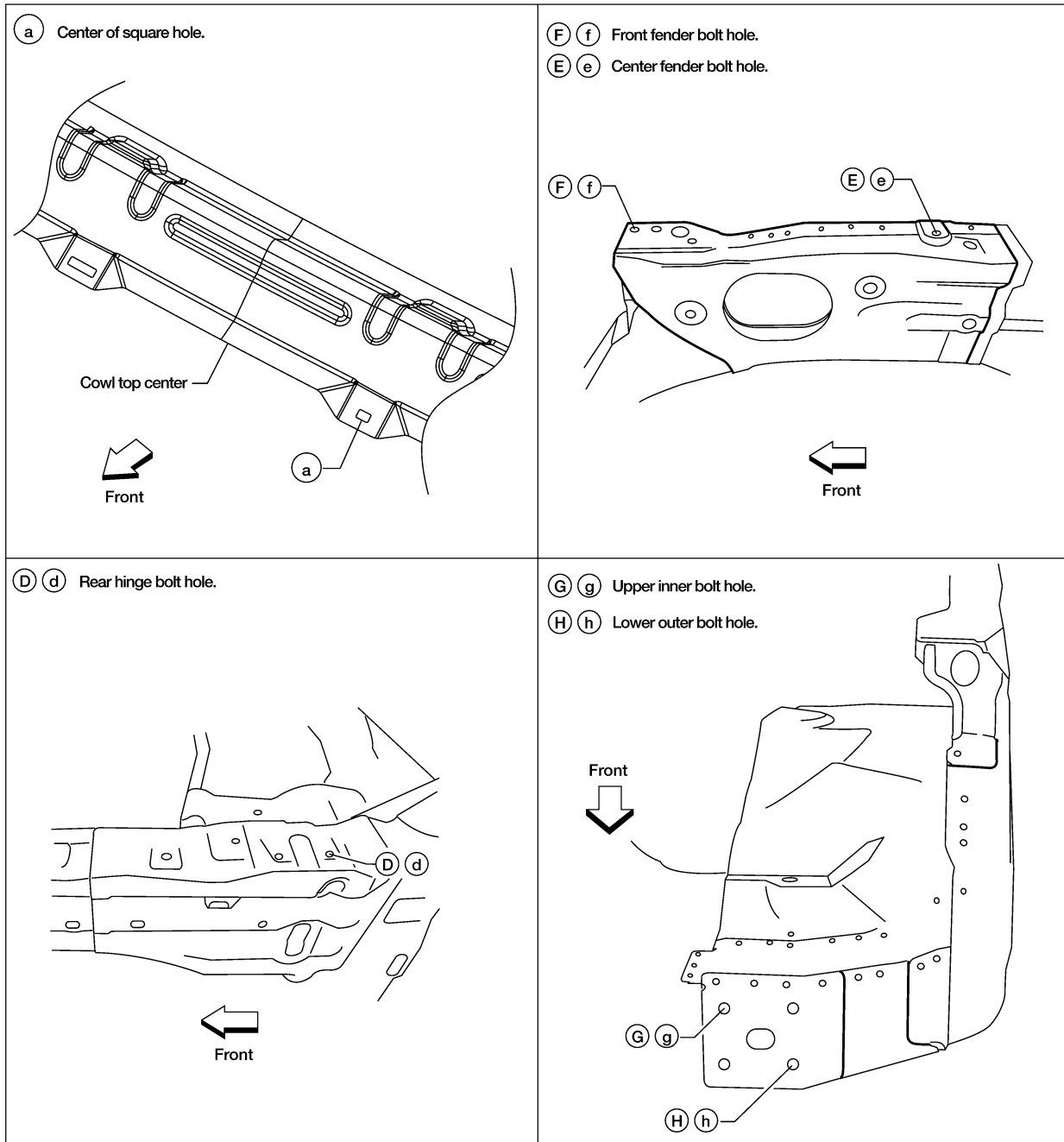

A  
B  
C  
D  
E  
F  
G  
H  
BL  
J  
K  
L  
M

LIIA2069E

# BODY REPAIR

## UNDERBODY MEASUREMENT

Figures marked with a (\*) indicate symmetrically identical dimensions on both right and left hand sides of the vehicle.

As viewed from underside.

LH side

All dimensions indicated in this figure are actual.

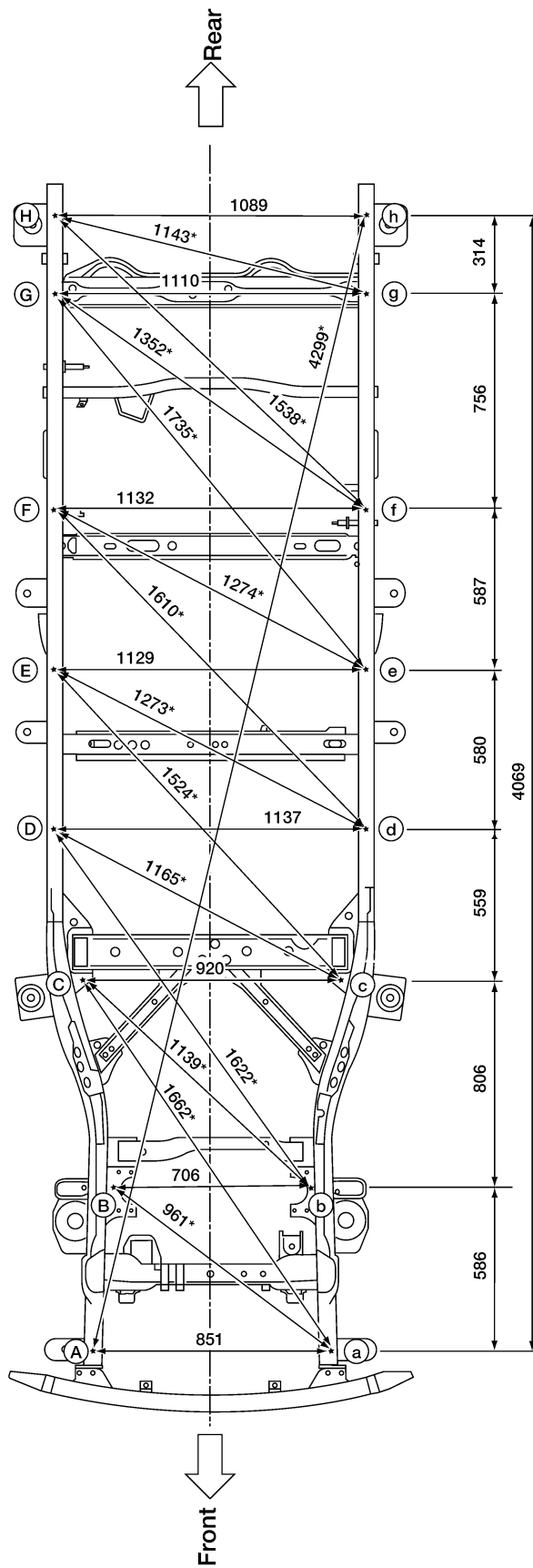

Unit: mm  
Top ← → Bottom

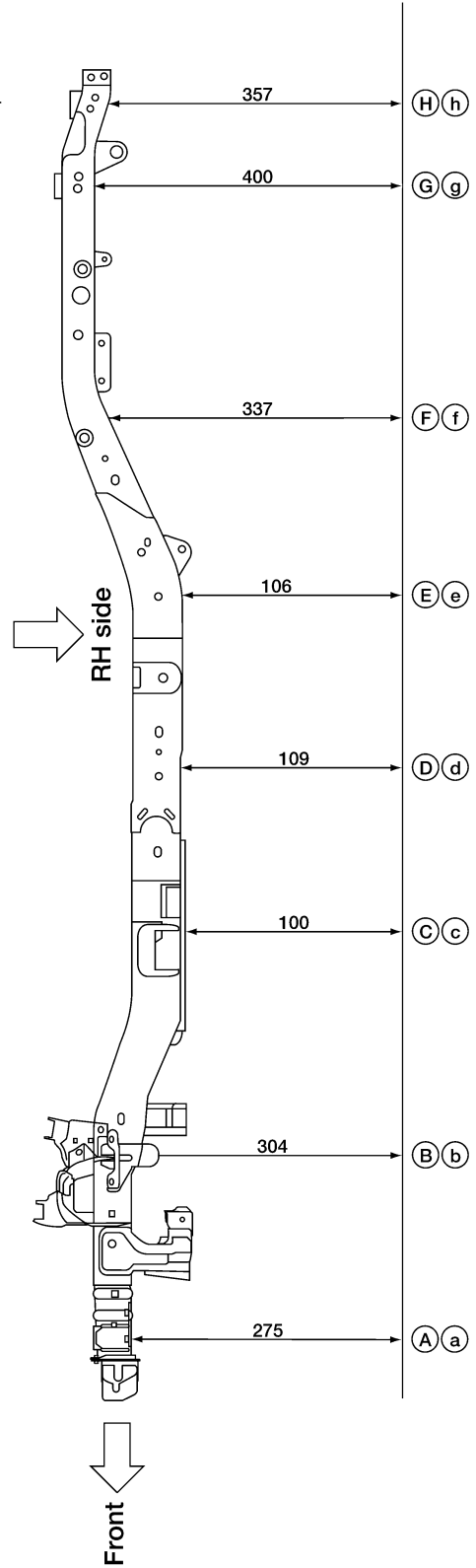

L1A2149E

# BODY REPAIR

## MEASUREMENT POINTS

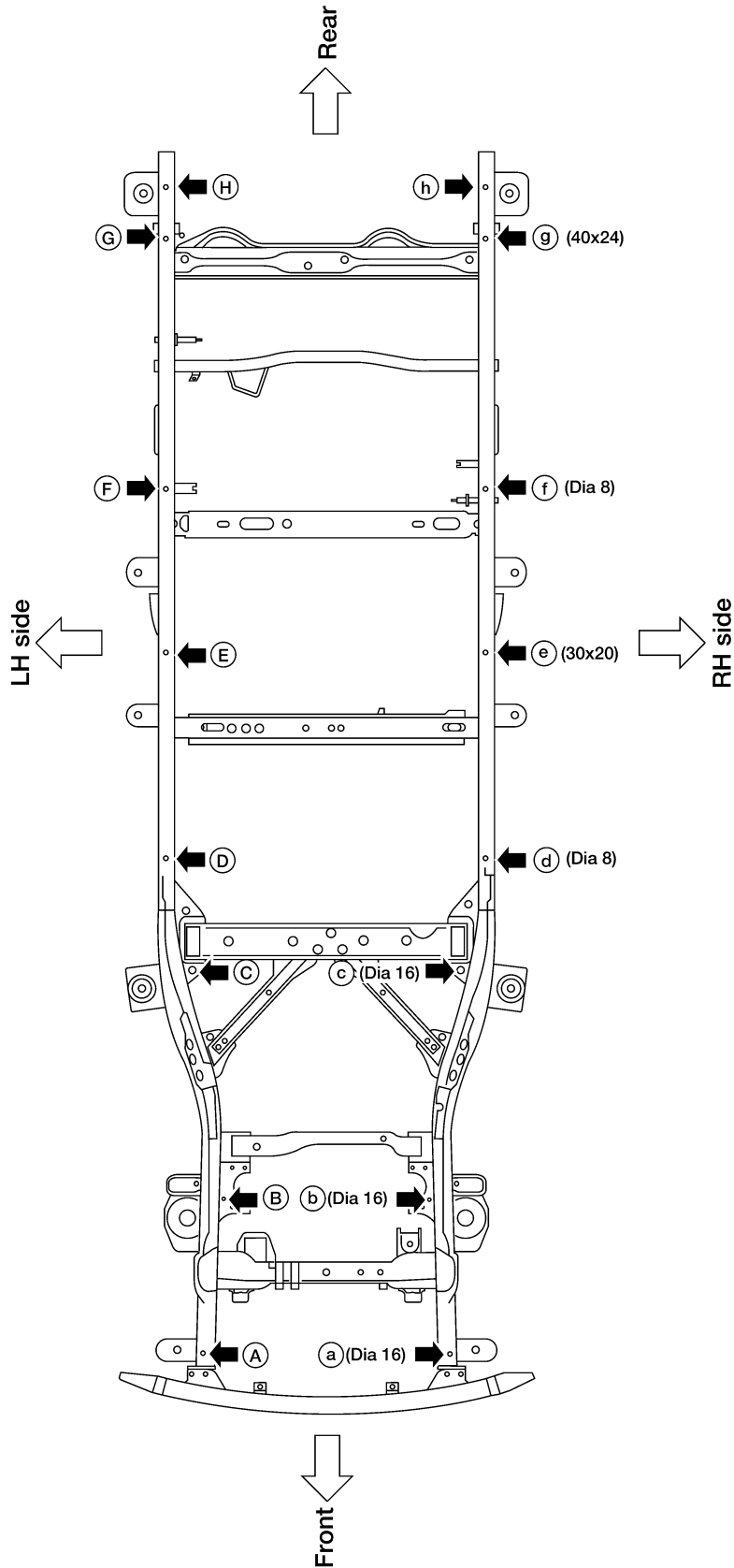

Coordinates:

- (A), (a)  
X: ± 425  
Y: -528  
Z: 275
- (B), (b)  
X: ± 353  
Y: 35  
Z: 304
- (C), (c)  
X: ± 460  
Y: 807  
Z: 100
- (D), (d)  
X: ± 568  
Y: 1356  
Z: 109
- (E), (e)  
X: ± 564  
Y: 1936  
Z: 106
- (F), (f)  
X: ± 566  
Y: 2475  
Z: 337
- (G), (g)  
X: ± 544  
Y: 3228  
Z: 400
- (H), (h)  
X: ± 544  
Y: 3539  
Z: 357

A  
B  
C  
D  
E  
F  
G  
H  
J  
K  
L  
M

BL

Unit: mm

LIIA2150E

# BODY REPAIR

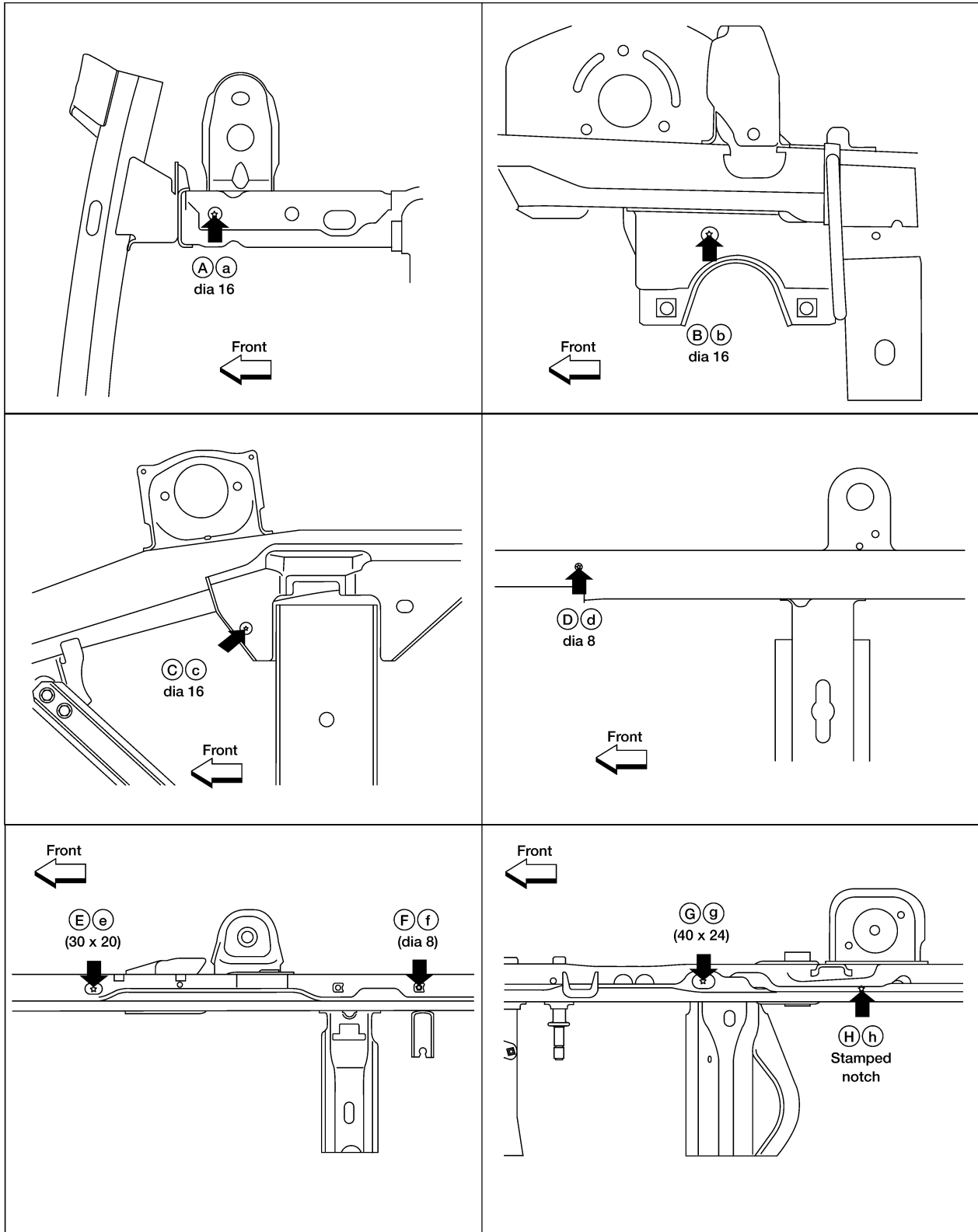

Coordinates:	(A/a)	(B/b)	(C/c)	(D/d)	(E/e)	(F/f)	(G/g)	(H/h)
X : ± 425	X : ± 353	X : ± 460	X : ± 568	X : ± 564	X : ± 566	X : ± 544	X : ± 544	
Y : -528	Y : 35	Y : 807	Y : 1356	Y : 1936	Y : 2475	Y : 3228	Y : 3539	
Z : 275	Z : 304	Z : 100	Z : 109	Z : 106	Z : 337	Z : 400	Z : 357	

Unit: mm

LIA2151E



# BODY REPAIR

## PASSENGER COMPARTMENT MEASUREMENT

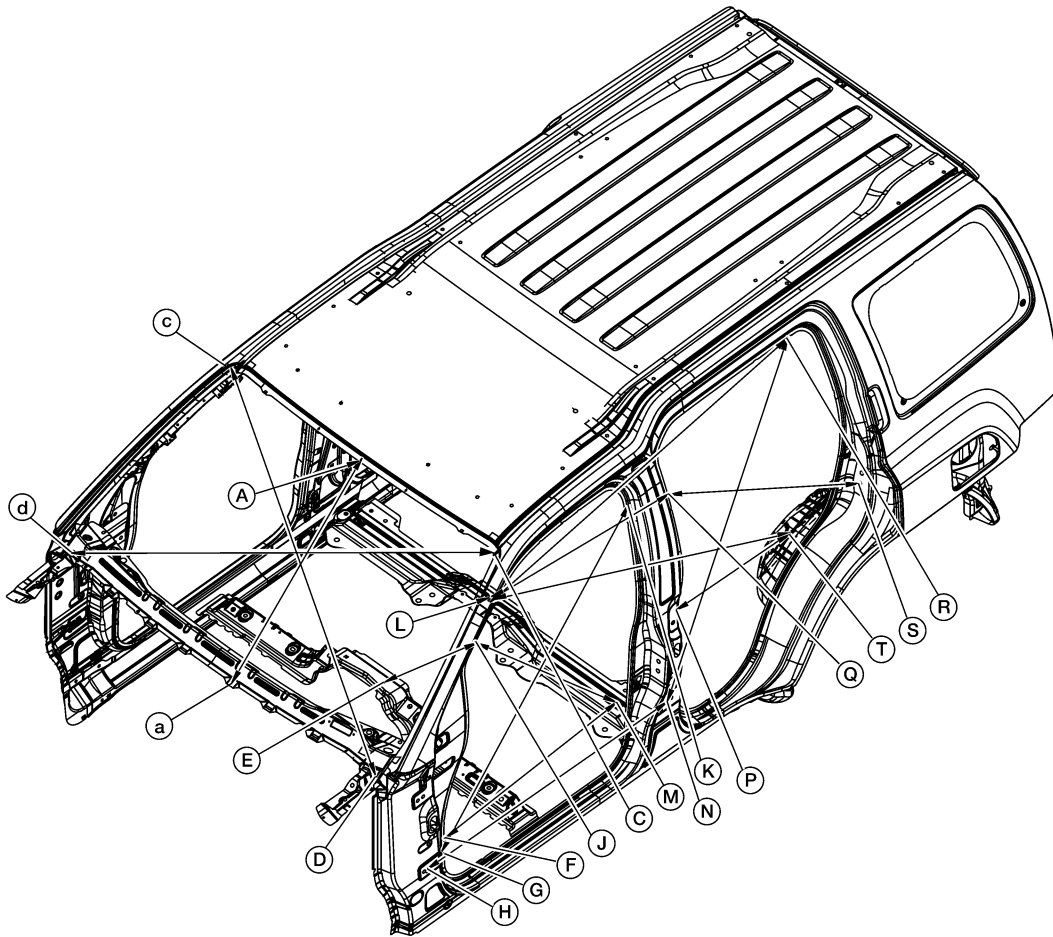

MEASURING POINT	DIM (mm)
A-a	840.0
C-d	1488.2
D-c	1528.2
E-J	1009.0
E-j	1101.0
E-K	1160.7
E-k	1238.5
F-M, f-m	844.2
G-K, g-k	1258.9
H-N, h-n	1095.2
J-M, j-m	954.7
L-Q, l-q	1115.0
L-R, l-r	1450.9
L-T, l-t	955.2
N-R, n-r	1265.3
P-S, p-s	847.8
Q-S, q-s	878.5

Unit: mm

LIA2070E

# BODY REPAIR

## MEASUREMENT POINTS

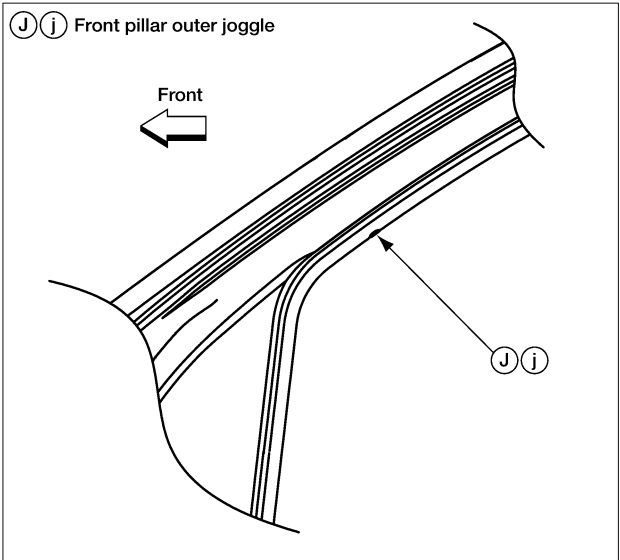
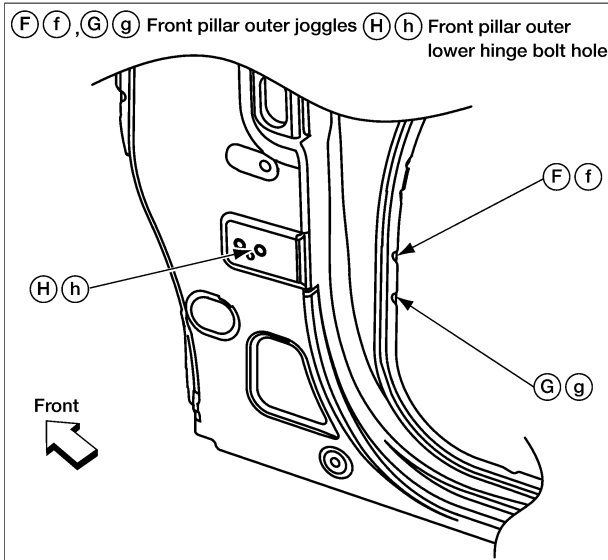
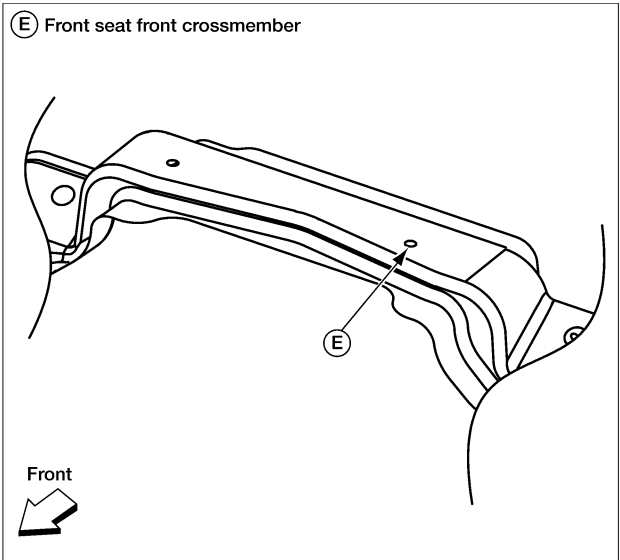
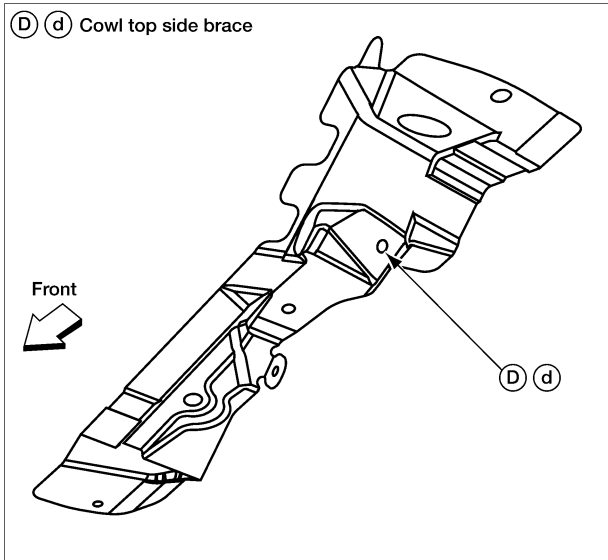
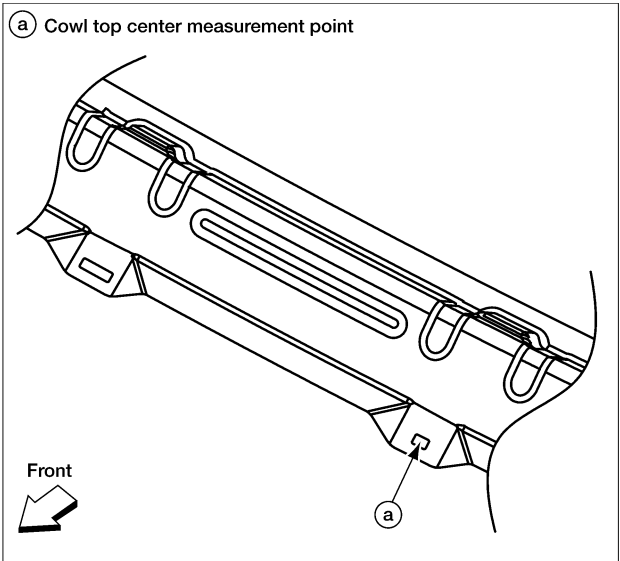
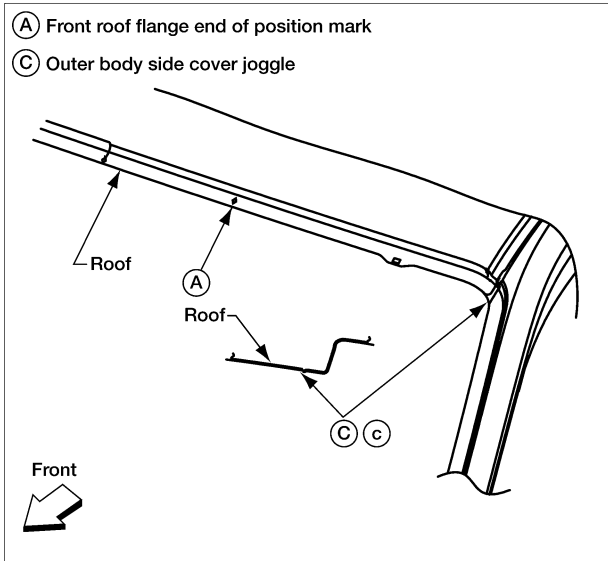

L1IA2072E

# BODY REPAIR

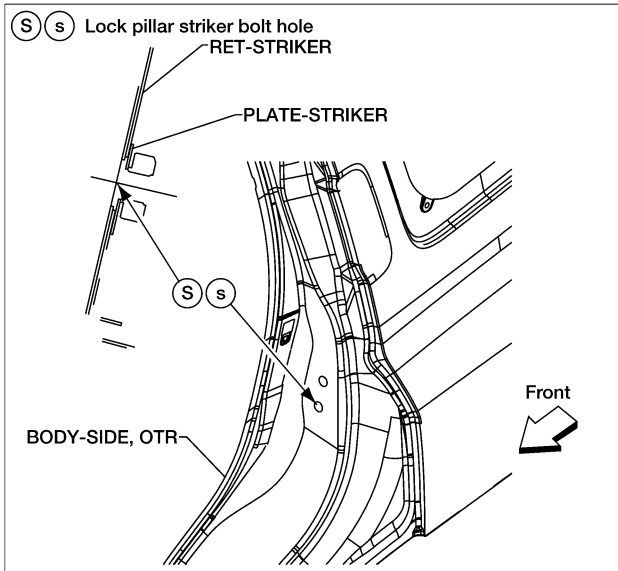
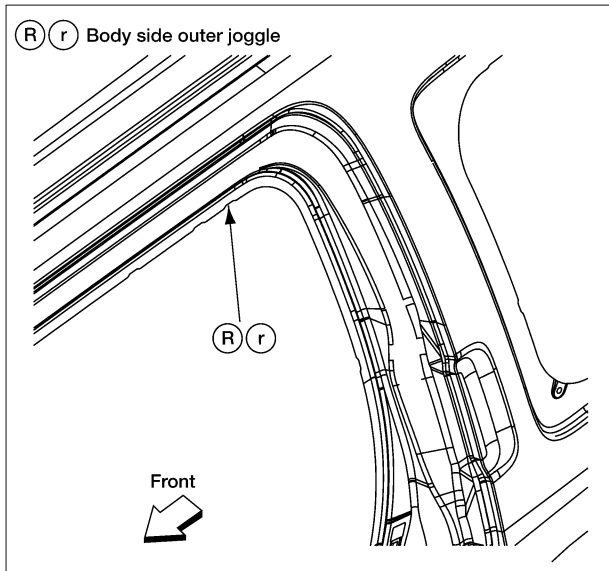
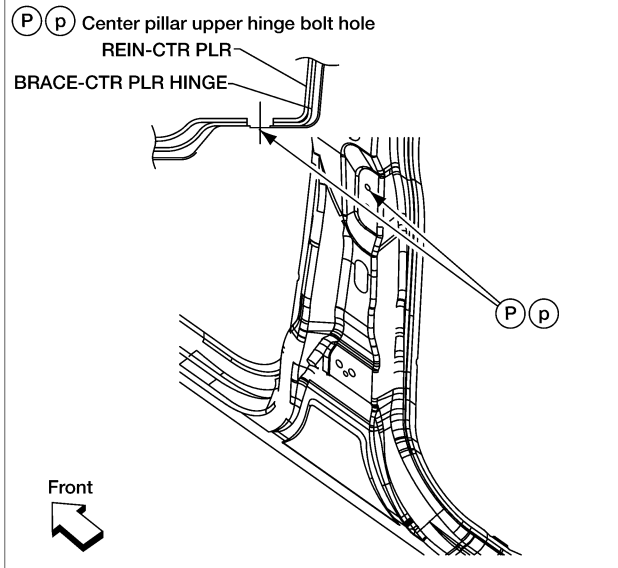
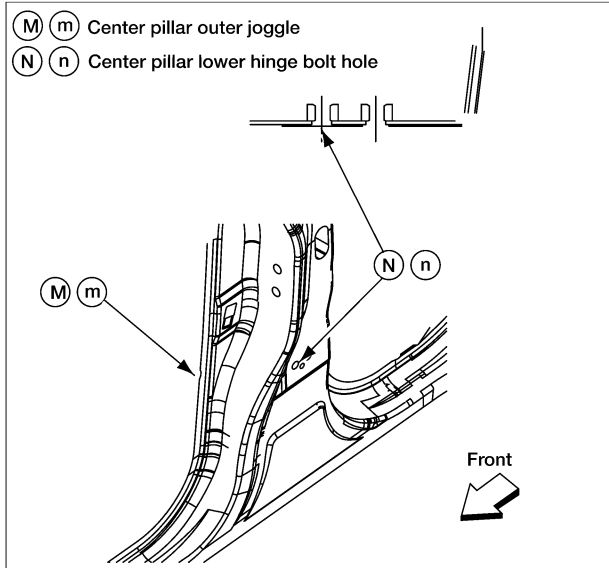
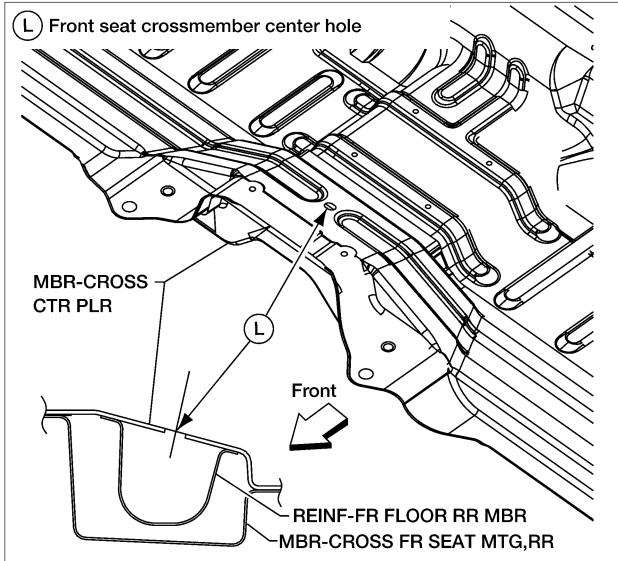
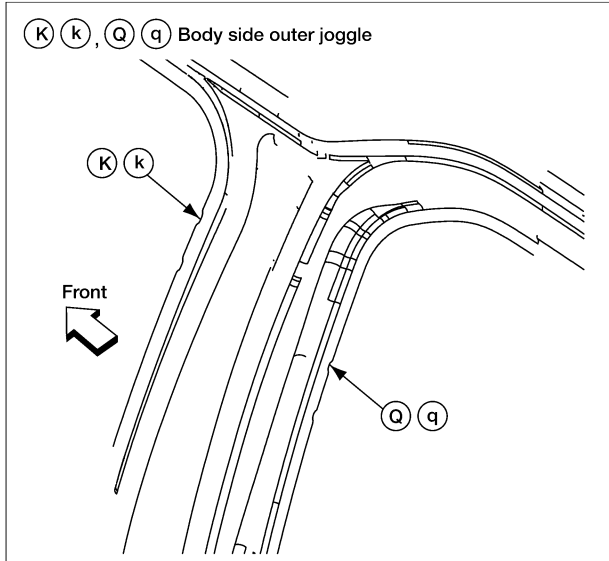

A  
B  
C  
D  
E  
F  
G  
H  
BL  
J  
K  
L  
M

LIA2073E

# BODY REPAIR

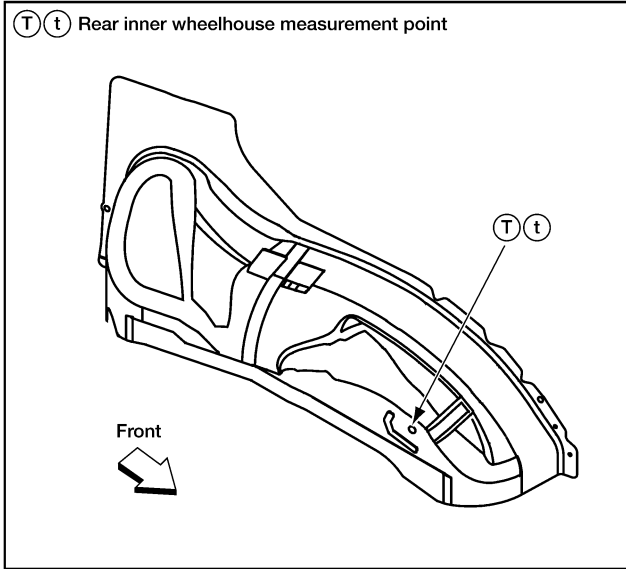

LIA2074E

# BODY REPAIR

## REAR BODY MEASUREMENT

Figures marked with a (\*) indicate symmetrically identical dimensions on both right and left sides of vehicle.

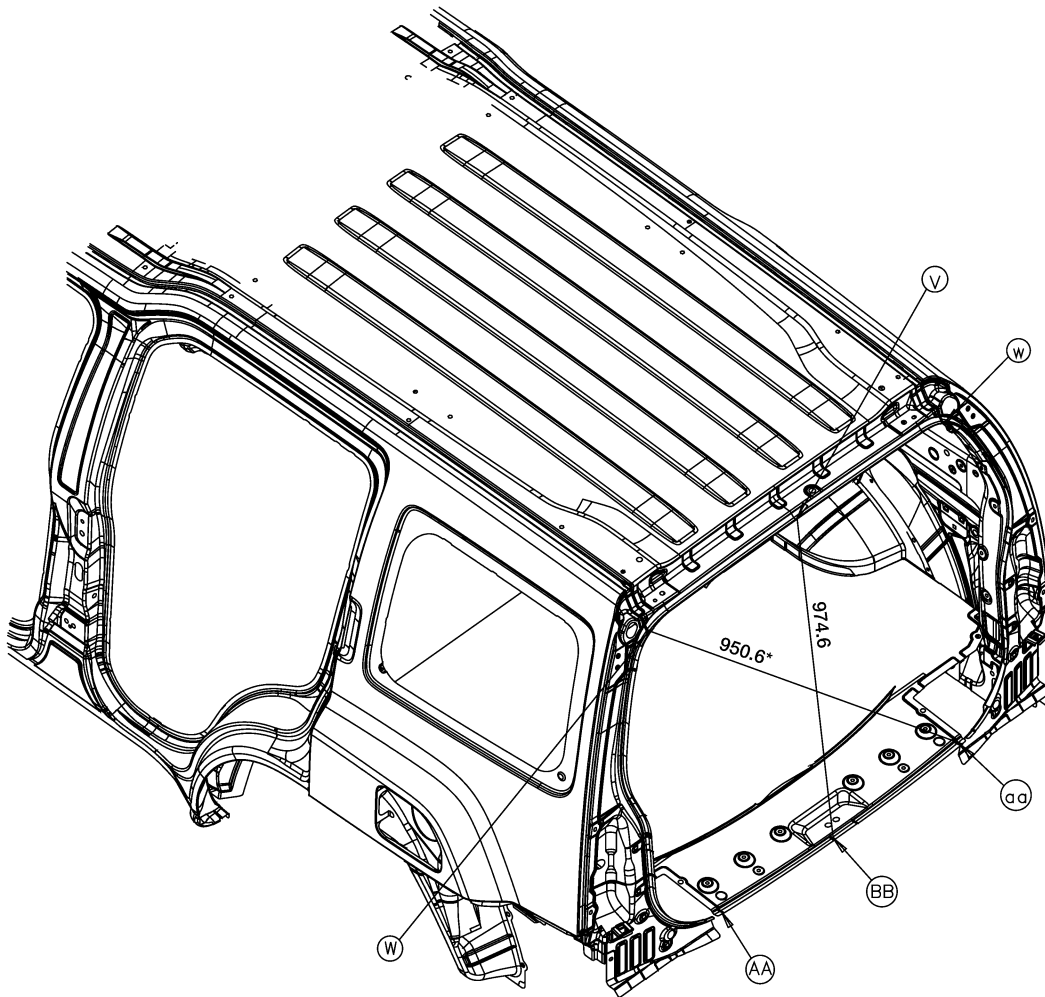

A  
B  
C  
D  
E  
F  
G  
H  
BL  
J  
K  
L  
M

Unit: mm

LIA2075E

# BODY REPAIR

## MEASUREMENT POINTS

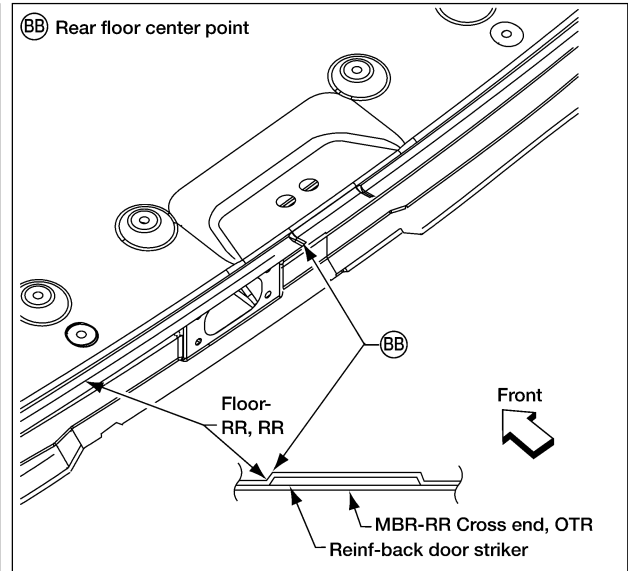
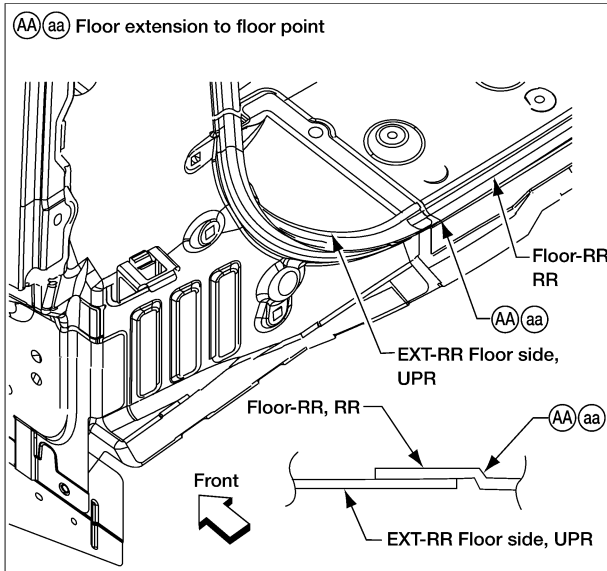
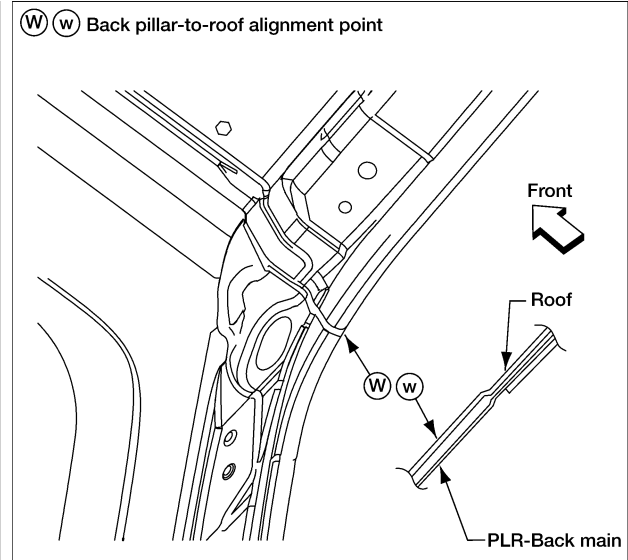
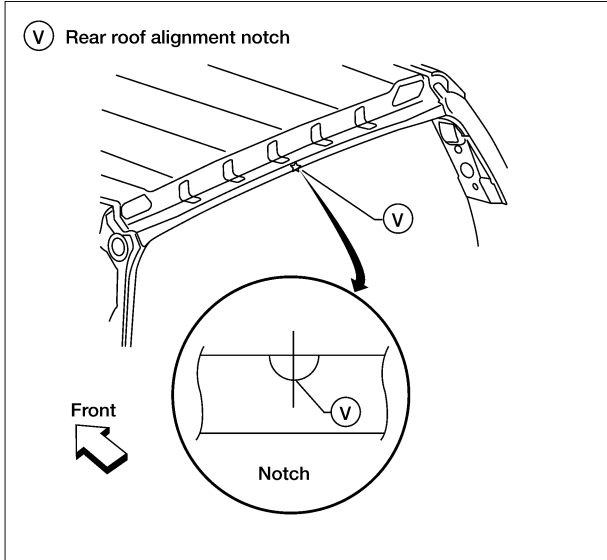

LIA2076E

# BODY REPAIR

EIS00669

## Handling Precautions for Plastics HANDLING PRECAUTIONS FOR PLASTICS

Abbreviation	Material name	Heatresisting temperature °C (°F)	Resistance to gasoline and solvents	Other cautions
PE	Polyethylene	60 (140)	Gasoline and most solvents are harmless if applied for a very short time (wipe up quickly).	Flammable
PVC	Polyvinyl Chloride	80 (176)	Same as above.	Poison gas is emitted when burned.
EPM/EPDM	Ethylene Propylene (Diene) rubber	80 (176)	Same as above.	Flammable
TPO/TPR	Thermoplastic Olefine/Thermoplastic Rubber	80 (176)	Same as above.	Flammable
PP	Polypropylene	90 (194)	Same as above.	Flammable, avoid battery acid.
UP	Polyester thermoset	90 (194)	Same as above.	Flammable
PS	Polystyrene	80 (176)	Avoid solvents.	Flammable
ABS	Acrylonitrile Butadiene Styrene resin	80 (176)	Avoid gasoline and solvents.	
AES	Acrylonitrile Ethylene Styrene	80 (176)	Same as above.	
PMMA	Polymethyl Methacrylate	85 (185)	Same as above.	
AAS	Acrylonitrile Acrylic Styrene	85 (185)	Same as above.	
AS	Acrylonitrile Styrene	85 (185)	Same as above.	
EVA	Polyvinyl Ethyl Acetate	90 (194)	Same as above.	
ASA	Acrylonitrile Styrene Acrylate	100 (222)	Same as above.	Flammable
PPO/PPE	Polyphenylene Oxide/ Polyphenylene Ether	110 (230)	Same as above.	
PC	Polycarbonate	120 (248)	Same as above.	
PAR	Polyacrylate	180 (356)	Same as above.	
L-LDPE	Linear Low Density PE	45 (100)	Gasoline and most solvents are harmless.	Flammable
PUR	Polyurethane	90 (194)	Same as above.	
TPU	Thermoplastic Urethane	110 (230)	Same as above.	
PPC	Polypropylene Composite	115 (239)	Same as above.	Flammable
POM	Polyacetal	120 (248)	Same as above.	Avoid battery acid.
PBT+PC	Polybutylene Terephthalate+Polycarbonate	120 (248)	Same as above.	Flammable
PA	Polyamide (Nylon)	140 (284)	Same as above.	Avoid immersing in water.
PBT	Polybutylene Terephthalate	140 (284)	Same as above.	
FRP	Fiber Reinforced Plastics	170 (338)	Same as above.	Avoid battery acid.
PET	Polyethylene Terephthalate	180 (356)	Same as above.	
PEI	Polyetherimide	200 (392)	Same as above.	

1. When repairing and painting a portion of the body adjacent to plastic parts, consider their characteristics (influence of heat and solvent) and remove them if necessary or take suitable measures to protect them.
2. Plastic parts should be repaired and painted using methods suiting the materials' characteristics.

# BODY REPAIR

## LOCATION OF PLASTIC PARTS

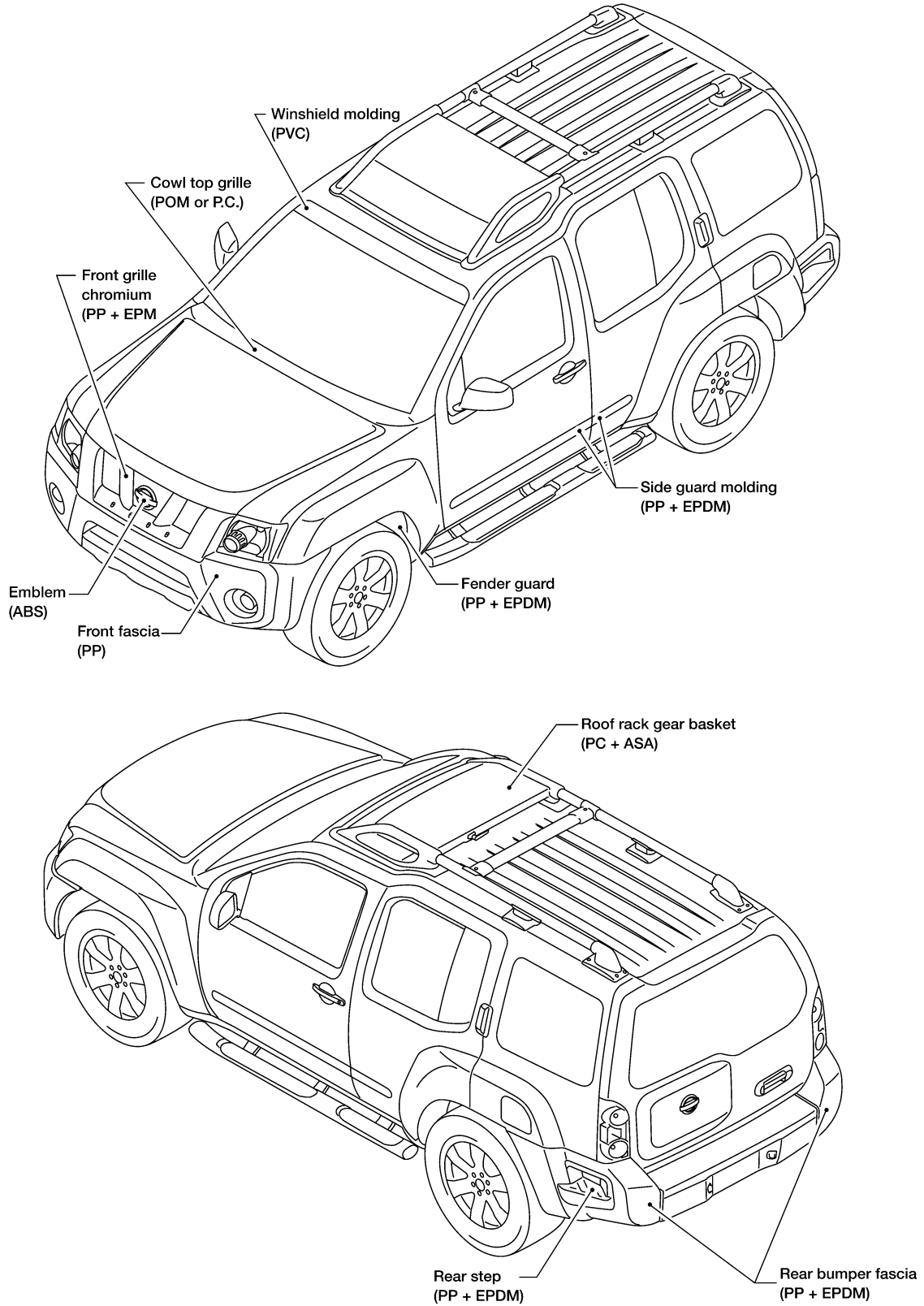

WI1A0862E



# BODY REPAIR

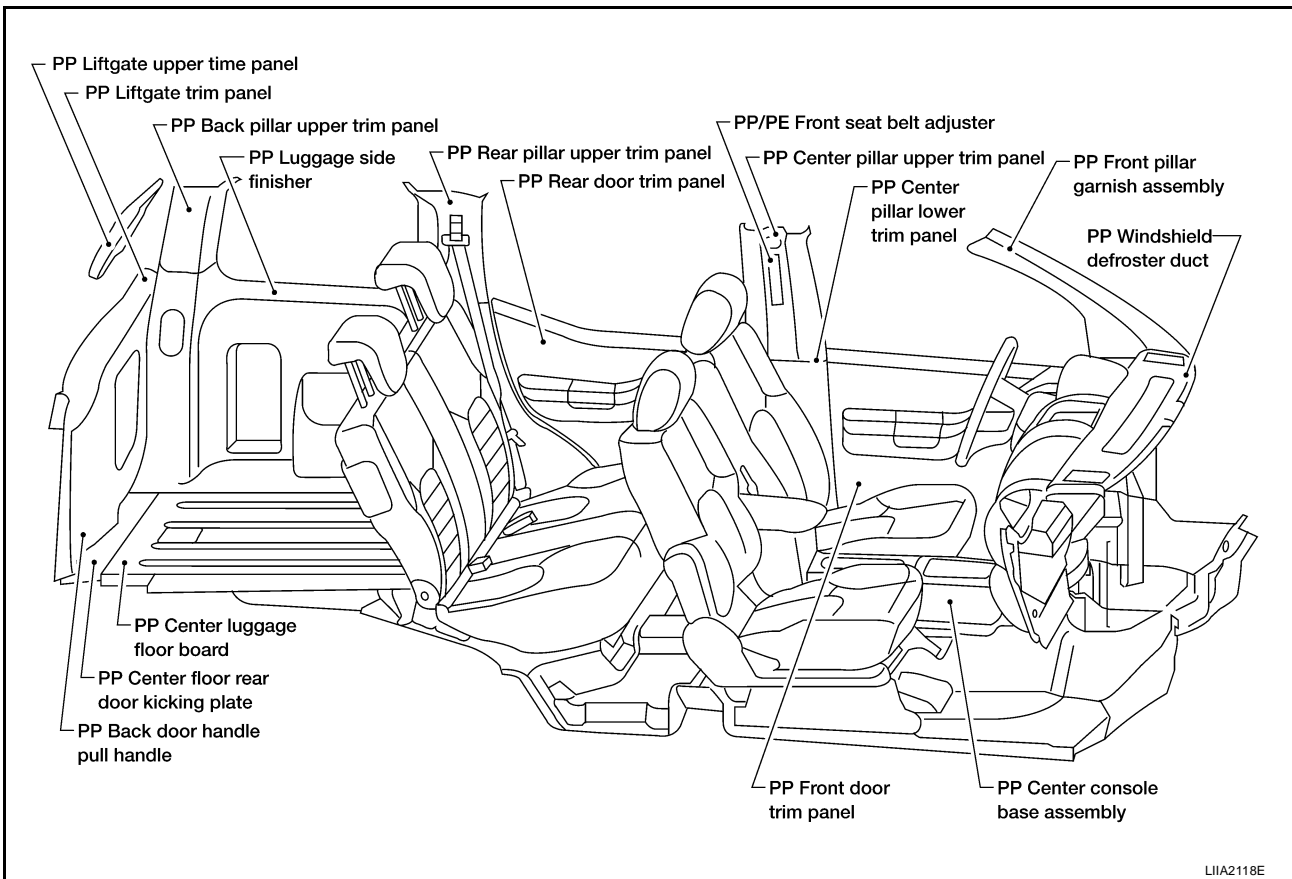

A  
B  
C  
D  
E  
F  
G  
H  
BL  
J  
K  
L  
M

# BODY REPAIR

EIS0066A

## Precautions in Repairing High Strength Steel

High strength steel is used for body panels in order to reduce vehicle weight. Accordingly, precautions in repairing automotive bodies made of high strength steel are described below:

### HIGH STRENGTH STEEL (HSS) USED IN NISSAN VEHICLES

Tensile strength	Nissan/Infiniti designation	Major applicable parts
373 N/mm <sup>2</sup> (38kg/mm <sup>2</sup> ,54klb/sq in)	SP130	<ul style="list-style-type: none"> <li>● Upper inner front pillar</li> <li>● Front pillar hinge brace</li> <li>● Outer front pillar reinforcement</li> <li>● Other reinforcements</li> </ul>
785-981 N/mm <sup>2</sup> (80-100kg/mm <sup>2</sup> 114-142klb/sq in)	SP150	<ul style="list-style-type: none"> <li>● Outer sill reinforcement</li> <li>● Main back pillar</li> </ul>

SP130 is the most commonly used HSS.

SP150 HSS is used only on parts that require much more strength.

Read the following precautions when repairing HSS:

#### 1. Additional points to consider

- The repair of reinforcements (such as side members) by heating is not recommended since it may weaken the component. When heating is unavoidable, do not heat HSS parts above 550°C (1,022°F). Verify heating temperature with a thermometer. (Crayon-type and other similar type thermometer are appropriate.)

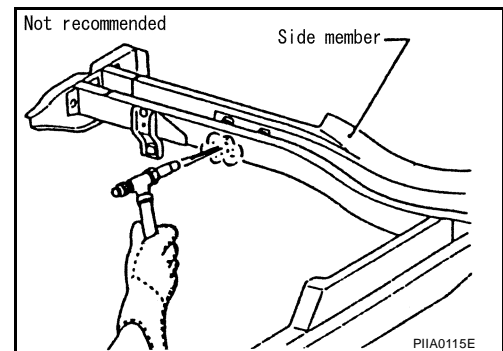

- When straightening body panels, use caution in pulling any HSS panel. Because HSS is very strong, pulling may cause deformation in adjacent portions of the body. In this case, increase the number of measuring points, and carefully pull the HSS panel.

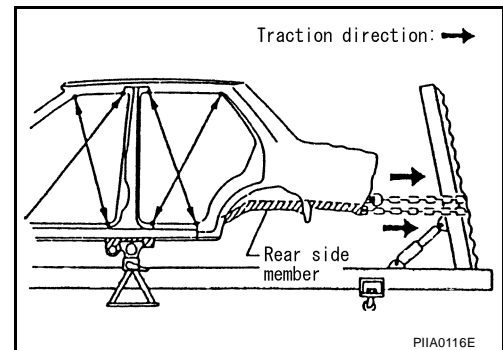

- When cutting HSS panels, avoid gas (torch) cutting if possible. Instead, use a saw to avoid weakening surrounding areas due to heat. If gas (torch) cutting is unavoidable, allow a minimum margin of 50 mm (1.97in).

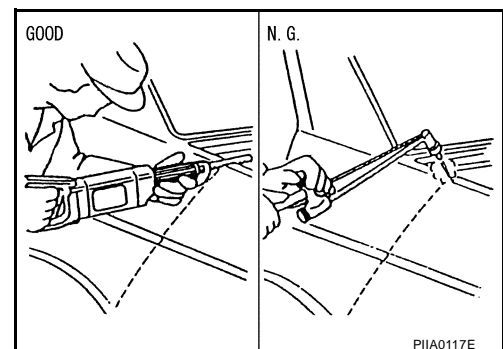

# BODY REPAIR

- When welding HSS panels, use spot welding whenever possible in order to minimize weakening surrounding areas due to heat. If spot welding is impossible, use M.I.G. welding. Do not use gas (torch) welding because it is inferior in welding strength.

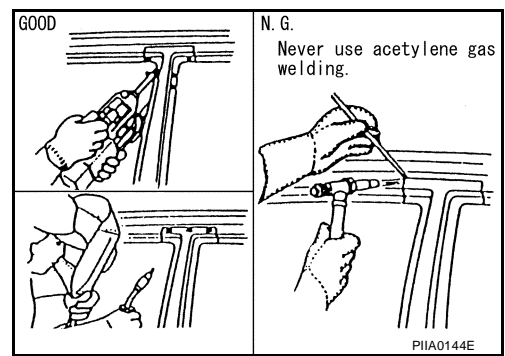

- The spot weld on HSS panels is harder than that of an ordinary steel panel. Therefore, when cutting spot welds on a HSS panel, use a low speed high torque drill (1,000 to 1,200 rpm) to increase drill bit durability and facilitate the operation.
- SP150 HSS panels with a tensile strength of 785 to 981 N/mm<sup>2</sup> (80 to 100 kg/mm<sup>2</sup>, 114 to 142 klb/sq in), used as reinforcement in the door guard beams, is too strong to repair. When these HSS parts are damaged, the outer panels also sustain substantial damage; therefore, the assembly parts must be replaced.

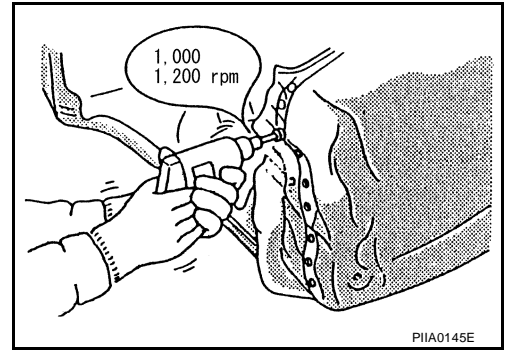

## 2. Precautions in spot welding HSS

This work should be performed under standard working conditions. Always note the following when spot welding HSS:

- The electrode tip diameter must be sized properly according to the metal thickness.

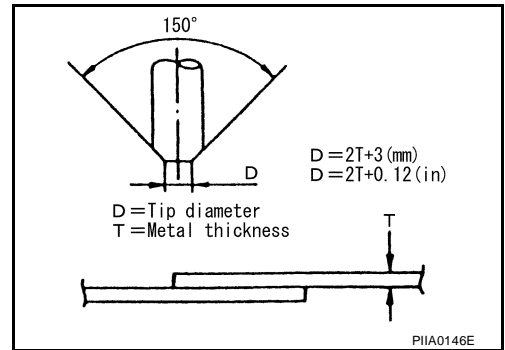

- The panel surfaces must fit flush to each other, leaving no gaps.

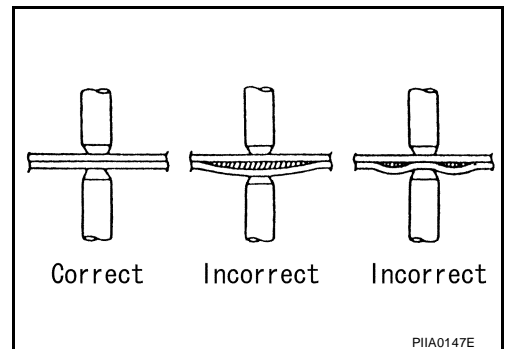

A  
B  
C  
D  
E  
F  
G  
H  
BL  
J  
K  
L  
M

# BODY REPAIR

- Follow the specifications for the proper welding pitch.

Thickness (t)	Minimum pitch (ℓ)
0.6 (0.024)	10 (0.39) or over
0.8 (0.031)	12 (0.47) or over
1.0 (0.039)	18 (0.71) or over
1.2 (0.047)	20 (0.79) or over
1.6 (0.063)	27 (1.06) or over
1.8 (0.071)	31 (1.22) or over

Unit:mm

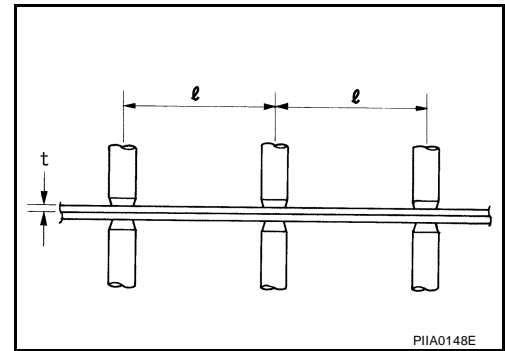

EIS0066B

## Foam Repair

During factory body assembly, foam insulators are installed in certain body panels and locations around the vehicle. Use the following procedure(s) to replace any factory-installed foam insulators.

### URETHANE FOAM APPLICATIONS

Use commercially available spray foam for sealant (foam material) repair of material used on vehicle. Read instructions on product for fill procedures.

### FILL PROCEDURES

1. Fill procedures after installation of service part.
  - Remove foam material remaining on vehicle side.
  - Clean area in which foam was removed.
  - Install service part.
  - Insert nozzle into hole near fill area and fill foam material or fill in enough to close gap with the service part.

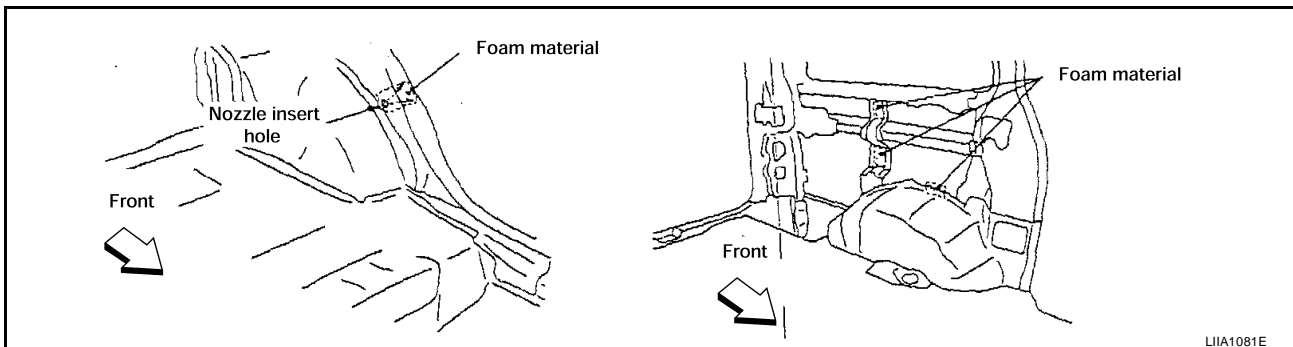

2. Fill procedures before installation of service part.
  - Remove foam material remaining on vehicle side.
  - Clean area in which foam was removed.
  - Fill foam material on wheelhouse outer side.

**NOTE:**

Fill in enough to close gap with service part while avoiding flange area.

- Install service part.

**NOTE:**

Refer to label for information on working times.

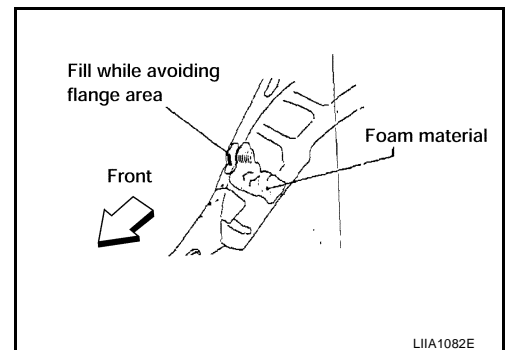

# BODY REPAIR

## Replacement Operations

EIS0066C

### DESCRIPTION

This section is prepared for technicians who have attained a high level of skill and experience in repairing collision-damaged vehicles and also use modern service tools and equipment. Persons unfamiliar with body repair techniques should not attempt to repair collision-damaged vehicles by using this section.

Technicians are also encouraged to read Body Repair Manual (Fundamentals) in order to ensure that the original functions and quality of the vehicle can be maintained. The Body Repair Manual (Fundamentals) contains additional information, including cautions and warnings, that are not including in this manual. Technicians should refer to both manuals to ensure proper repairs.

Please note that this information is prepared for worldwide usage, and as such, certain procedures may not apply in some regions or countries.

A

B

C

D

E

F

G

H

BL

J











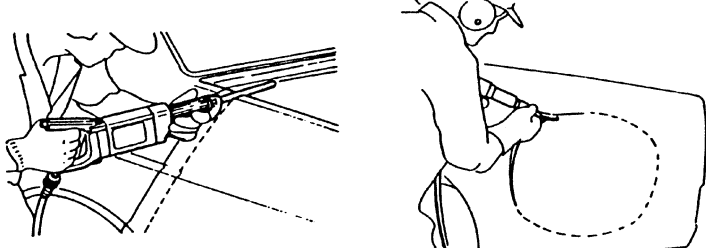

K

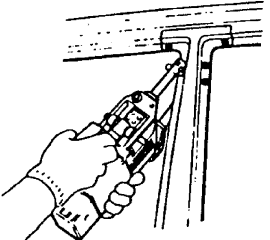
L

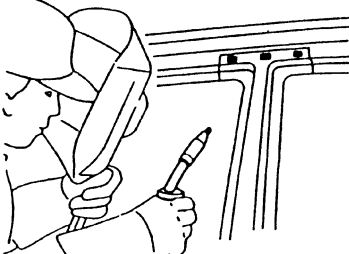
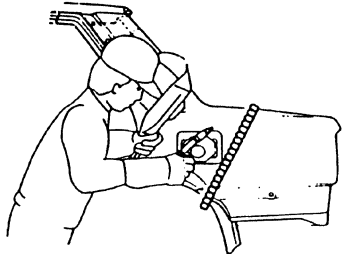
M

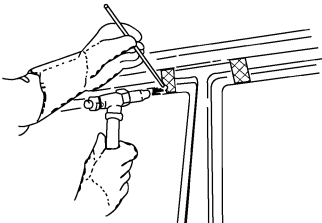
# BODY REPAIR

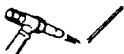
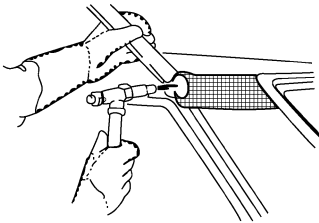
The symbols used in this section for cutting and welding / brazing operations are shown below.

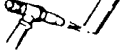
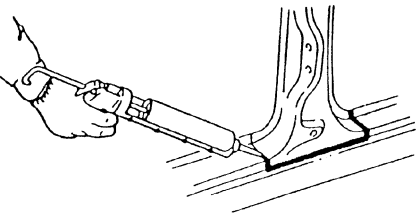
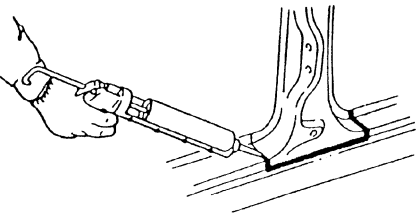
 <p>Saw cut or air chisel cut</p>		
<p>Spot weld</p> <p>● ● ● ● 2-spot welds</p>   <p>○ ● ● ● ○ 3-spot welds</p>	<p>2-spot welds (2-panel overlapping portions)</p>  <p>3-spot welds (3-panel overlapping portions)</p>	
<p>■ ■ ■ ■ MIG plug weld</p>  		
<p>⌒ ⌒ ⌒ ⌒ MIG seam weld/ Point weld</p> 		
<p>▨ ▨ ▨ ▨ Brazing</p>  		
<p>▩ ▩ ▩ ▩ Soldering</p>  		
<p>— Sealing</p>		

# BODY REPAIR

- Front pillar butt joint can be determined anywhere within shaded area as shown in the figure. The best location for the butt joint is at position A due to the construction of the vehicle. Refer to the front pillar section.

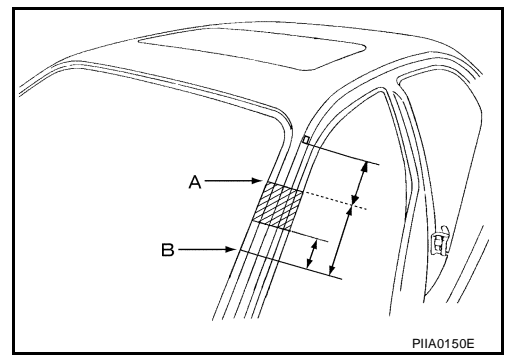

- Determine cutting position and record distance from the locating indent. Use this distance when cutting the service part. Cut outer front pillar over 60 mm above inner front pillar cut position.

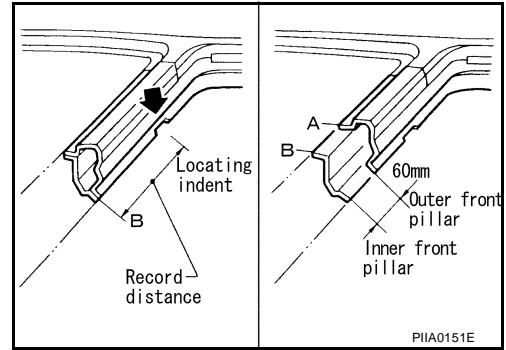

- Prepare a cutting jig to make outer pillar easier to cut. Also, this will permit service part to be accurately cut at joint position.

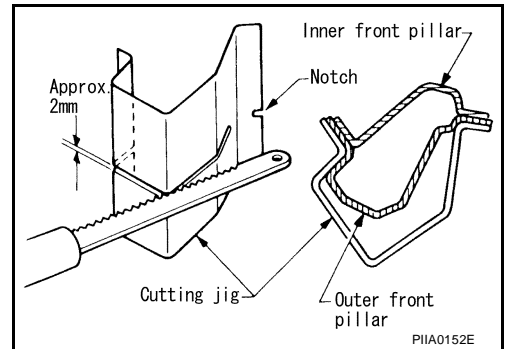

- An example of cutting operation using a cutting jig is as follows.

1. Mark cutting lines.  
A: Cut position of outer pillar  
B: Cut position of inner pillar
2. Align cutting line with notch on jig. Clamp jig to pillar.
3. Cut outer pillar along groove of jig. (At position A)
4. Remove jig and cut remaining portions.
5. Cut inner pillar at position B in same manner.

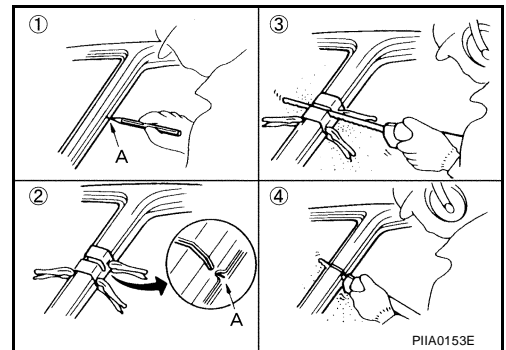

A  
B  
C  
D  
E  
F  
G  
H  
BL  
J  
K  
L  
M

# BODY REPAIR

## HOODLEDGE

### LH

- Work after radiator core support has been removed.

### Service Joint

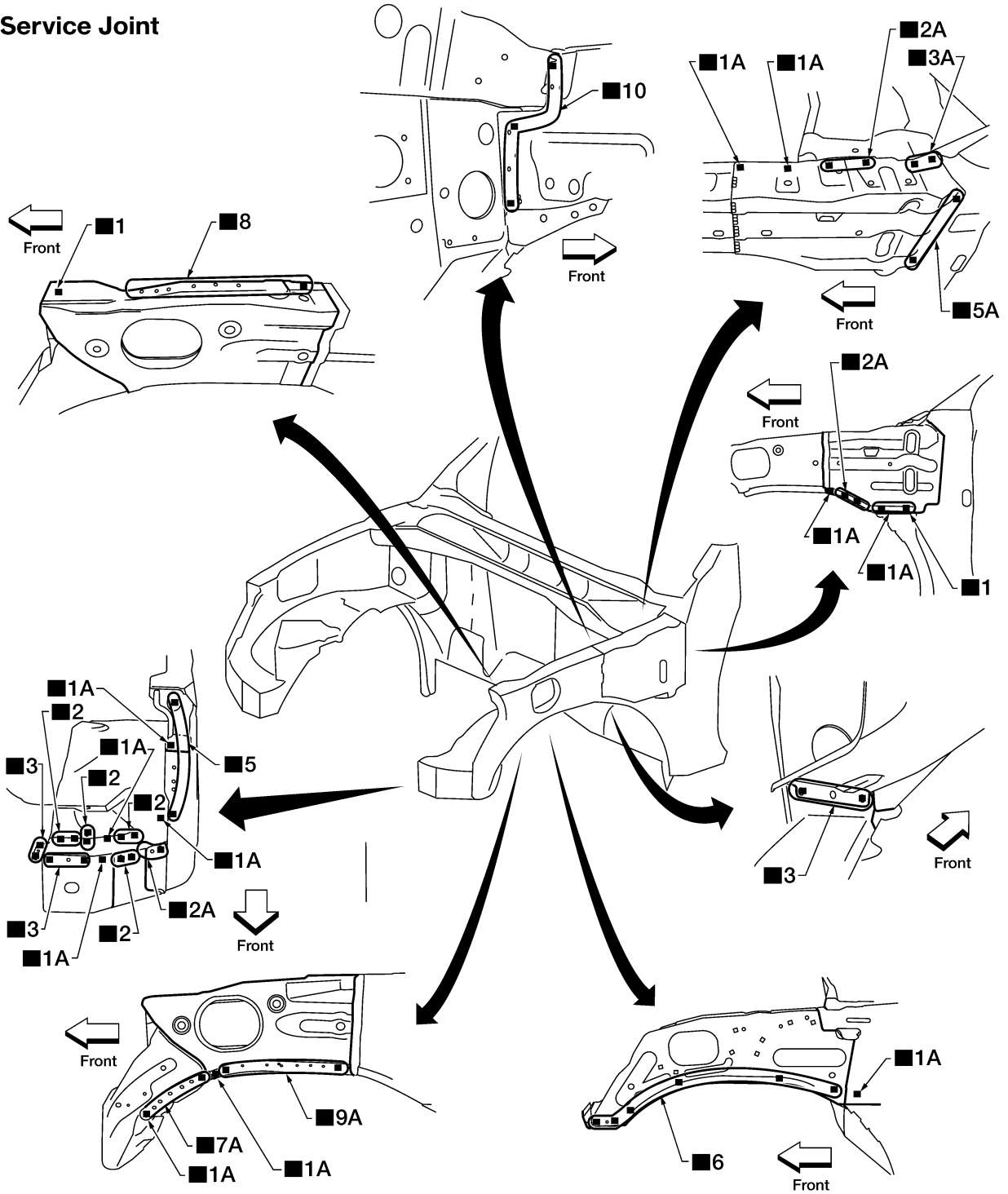

2-spot welds

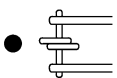

3-spot welds

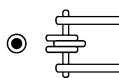

MIG Plug weld

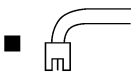

( For 3 panels plug weld method )



MIG seam weld/  
Point weld



LIA2119E



# BODY REPAIR

RH

- Work after radiator core support has been removed.

## Service Joint

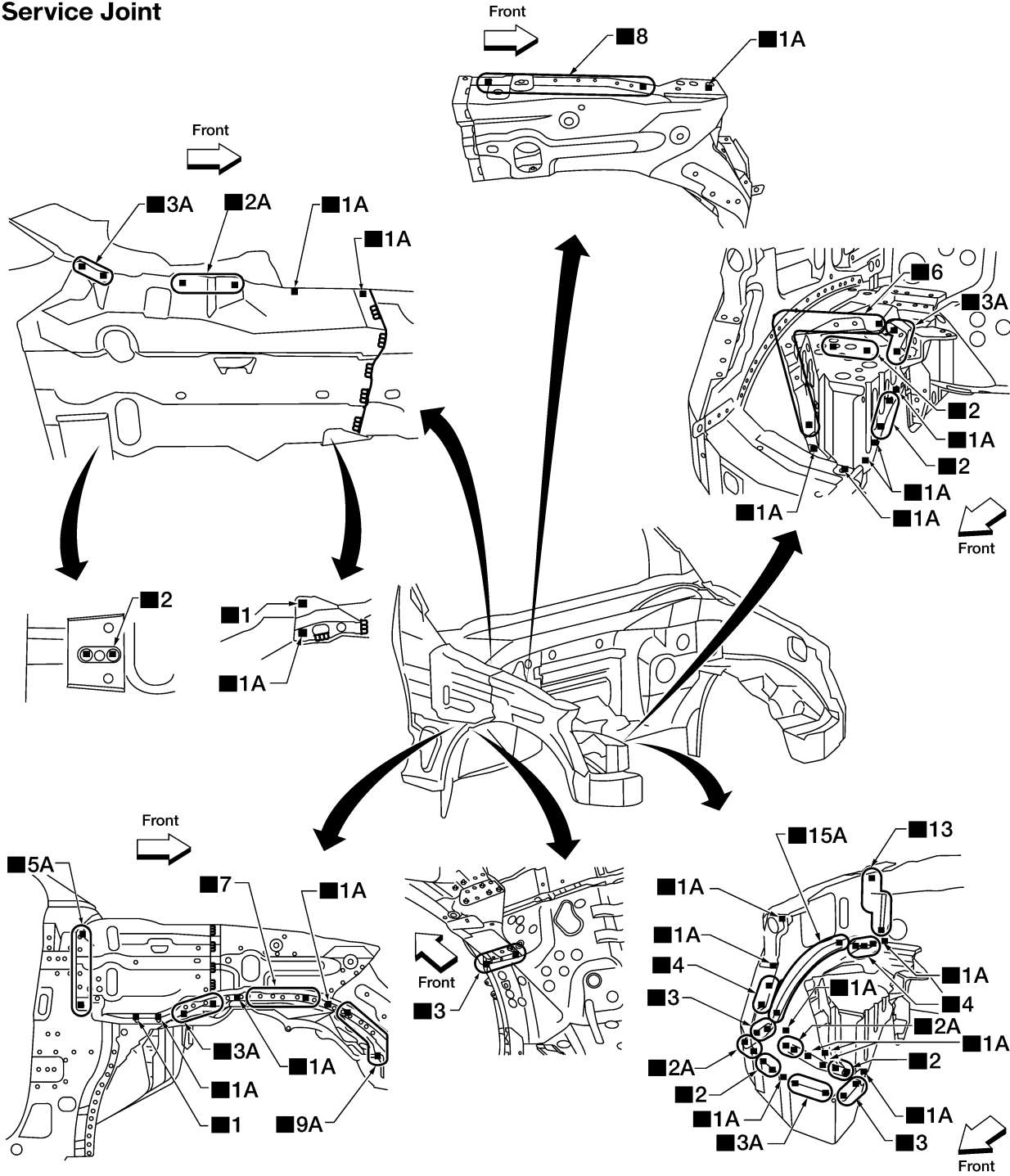

2-spot welds

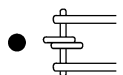

3-spot welds

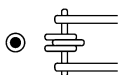

MIG Plug weld

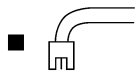

( For 3 panels plug weld method )



MIG seam weld/  
Point weld



LIA2120E

# BODY REPAIR

## FRONT PILLAR

- Work after rear hoodledge reinforcement has been removed.

### Service Joint

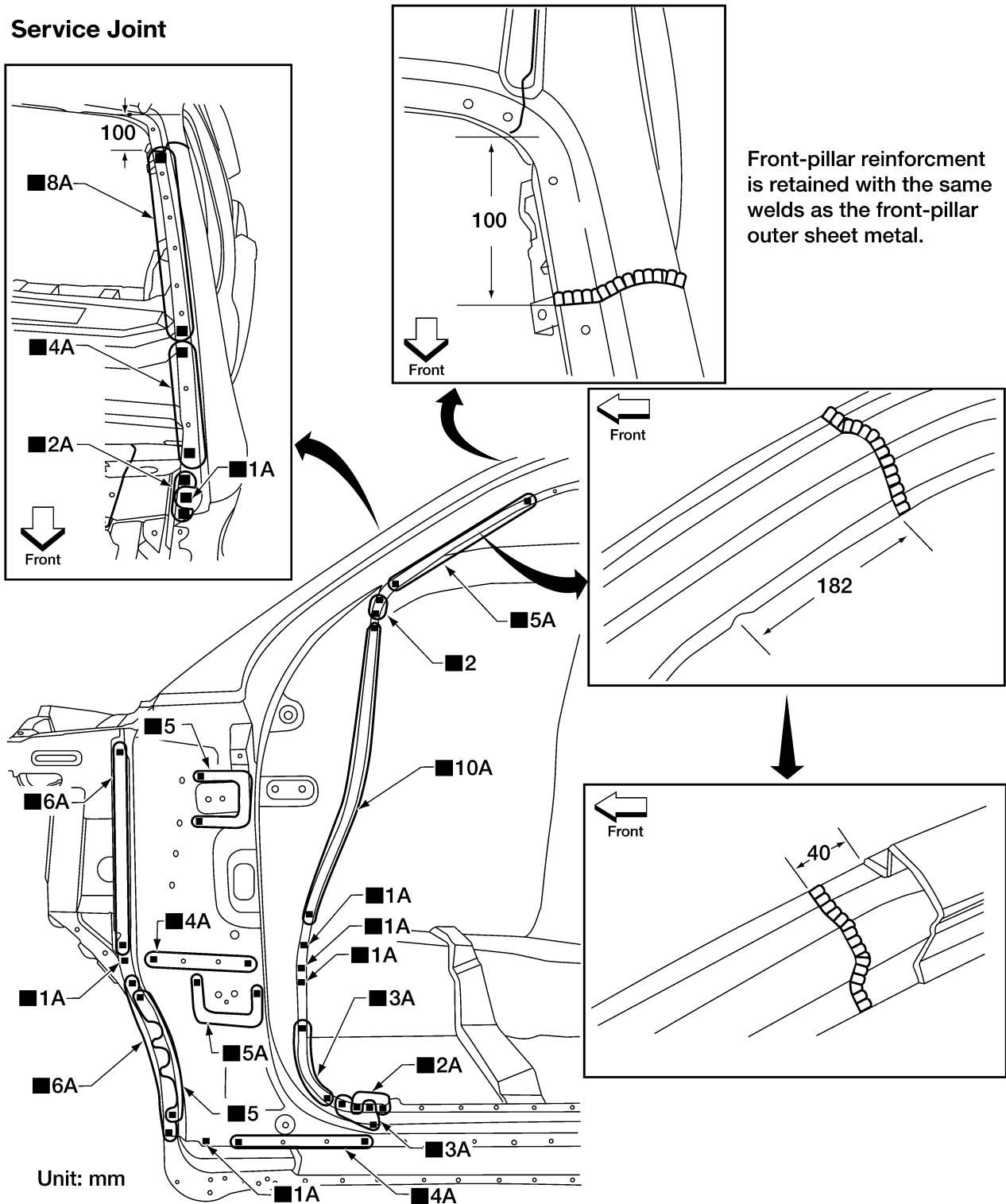

Front-pillar reinforcement is retained with the same welds as the front-pillar outer sheet metal.

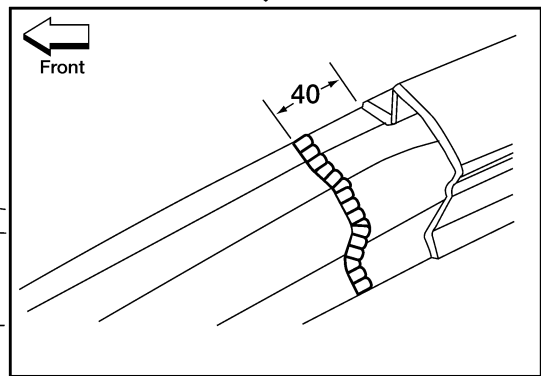
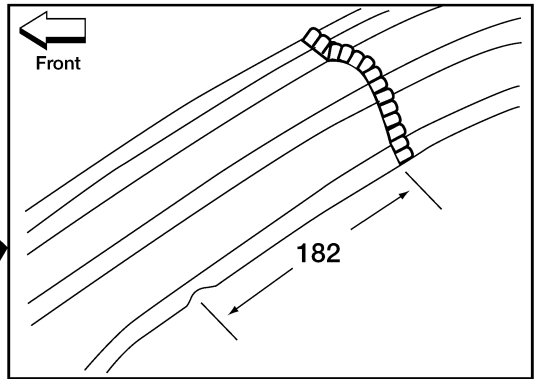
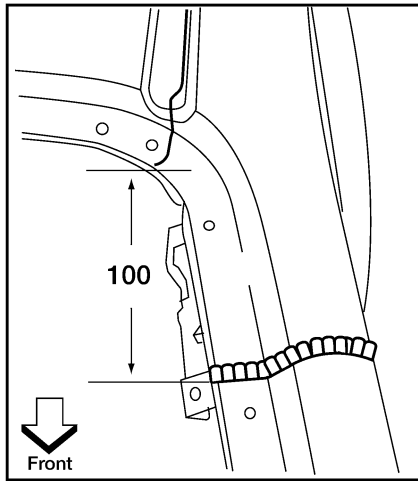

2-spot welds

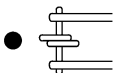

3-spot welds

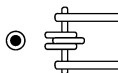

MIG Plug weld

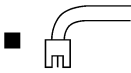

( For 3 panels plug weld method )

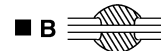

MIG seam weld/  
Point weld



W11A0863E

# BODY REPAIR

## CENTER PILLAR

### Service Joint

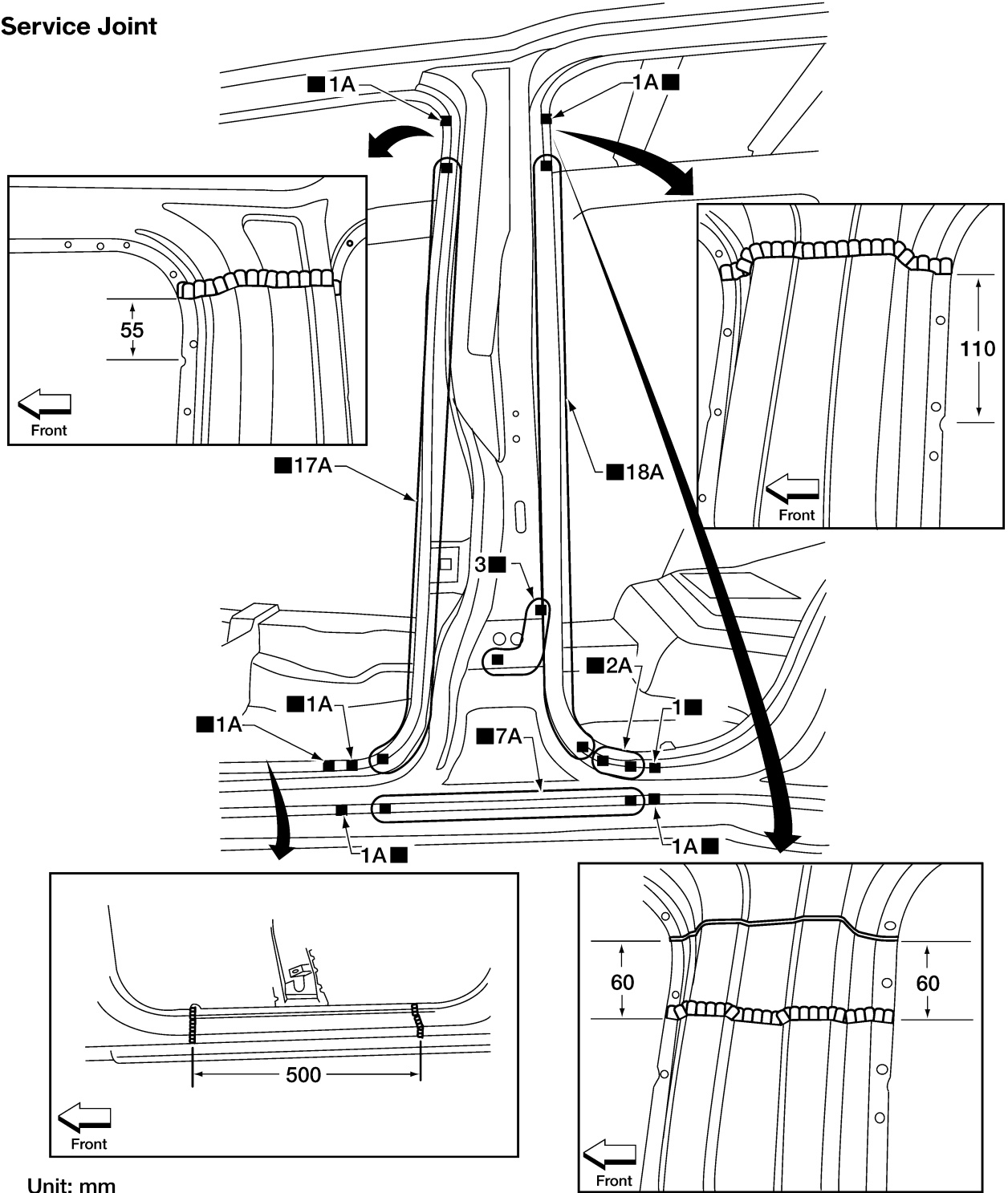

Unit: mm

2-spot welds

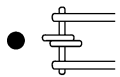

3-spot welds

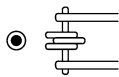

MIG Plug weld

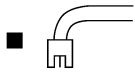

( For 3 panels plug weld method )



MIG seam weld/  
Point weld



WIHA0864E

# BODY REPAIR

## Service Joint

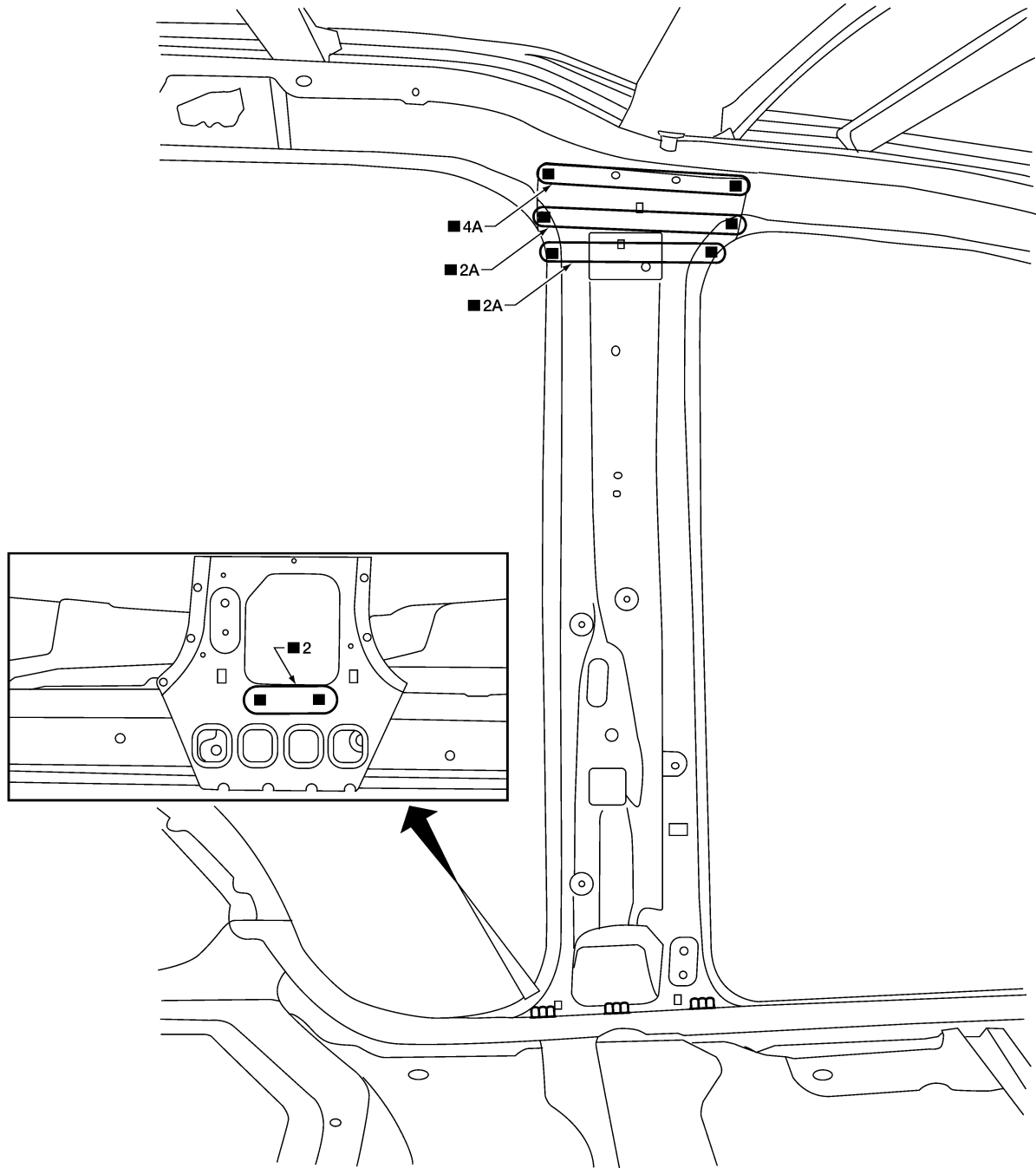

2-spot welds

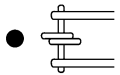

3-spot welds

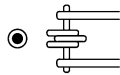

MIG Plug weld

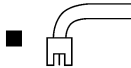

For 3 panels plug weld method



MIG seam weld/  
Point weld



LIA2123E

# BODY REPAIR

## OUTER SILL

### Service Joint

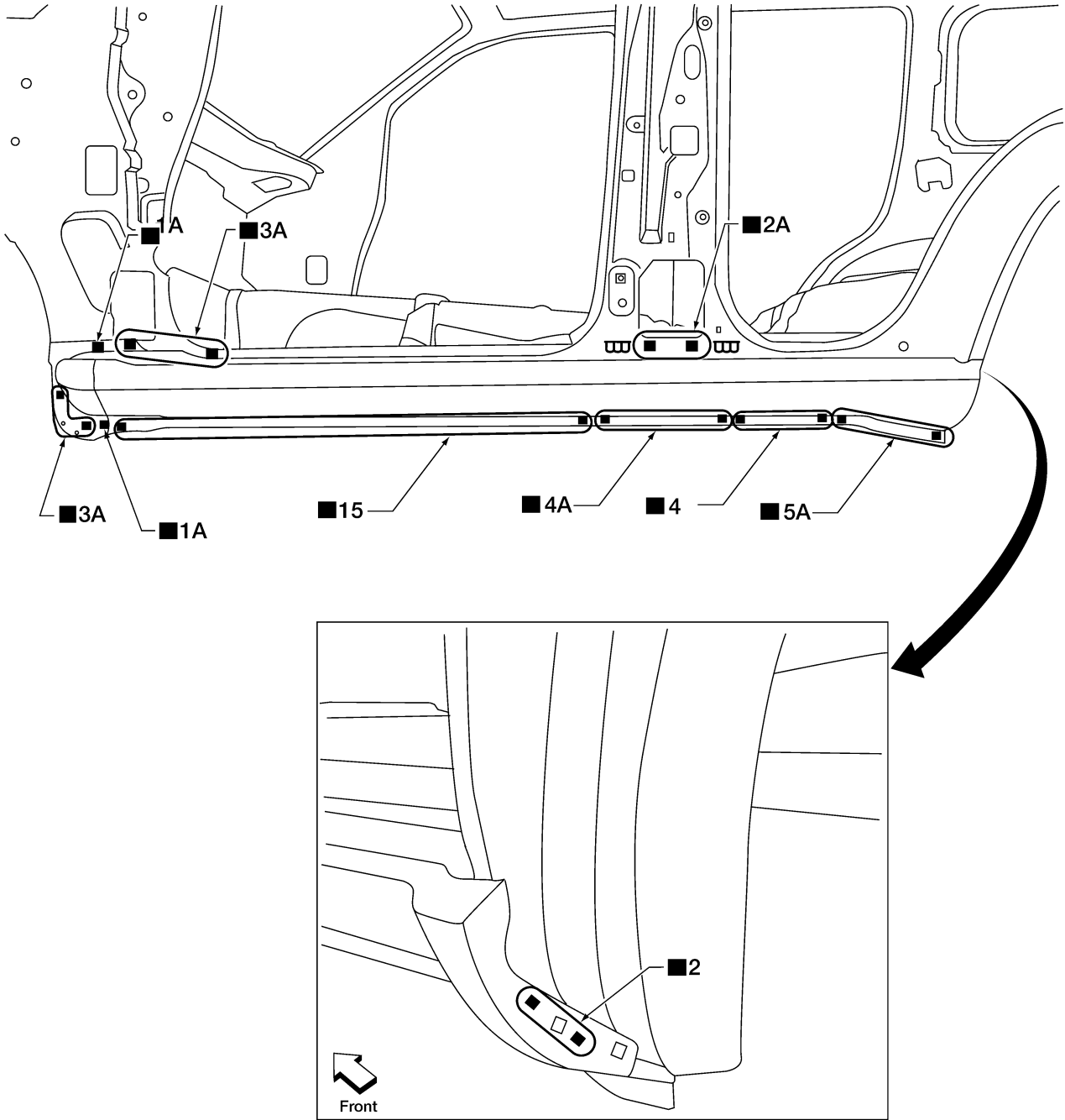

A  
B  
C  
D  
E  
F  
G  
H  
BL  
J  
K  
L  
M

2-spot welds

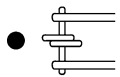

3-spot welds

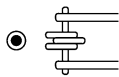

MIG Plug weld

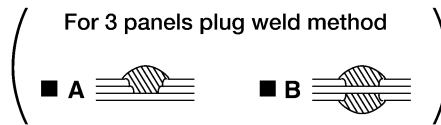
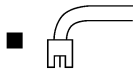

MIG seam weld/  
Point weld



W11A0865E

# BODY REPAIR

## REAR FENDER

### Service Joint

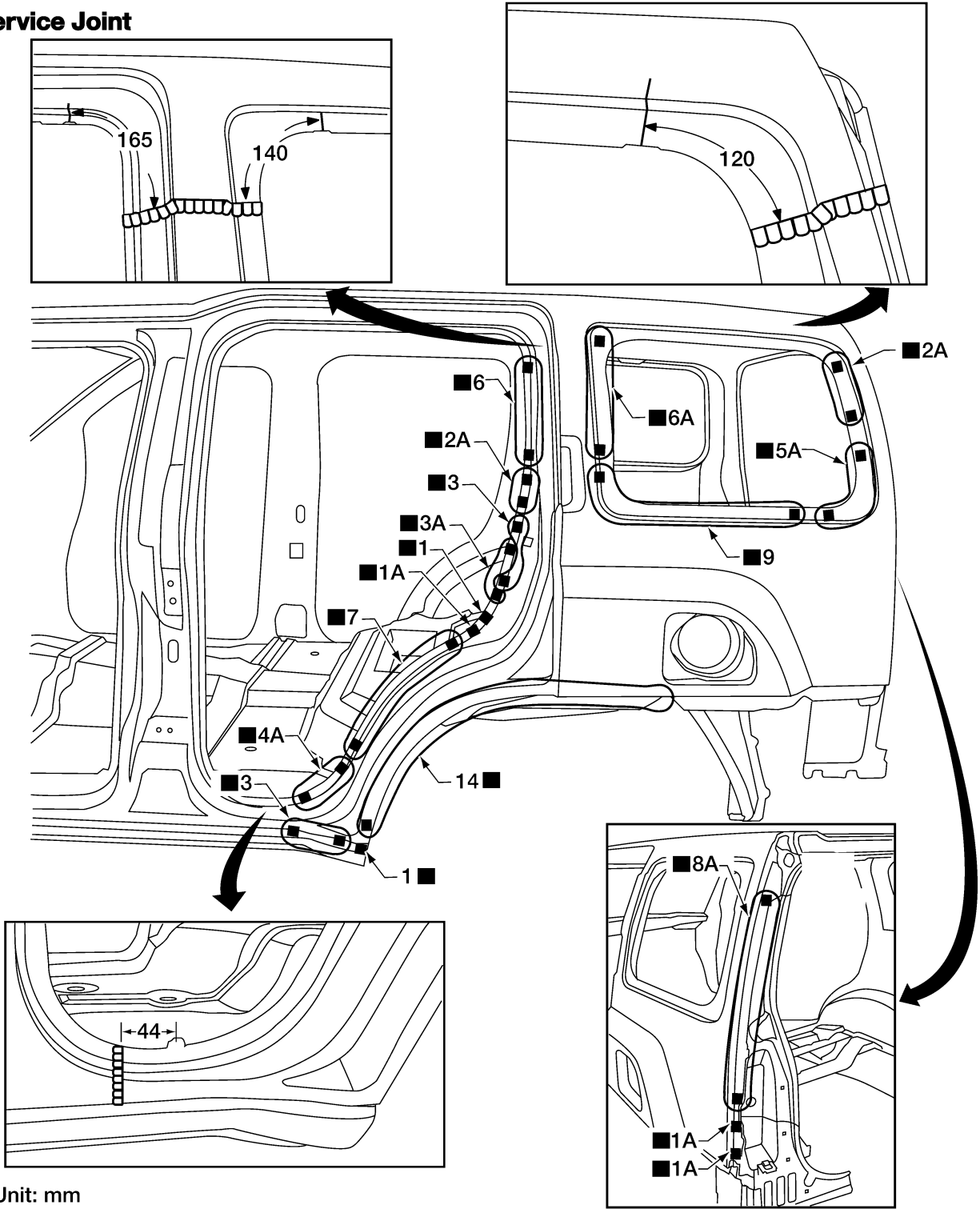

Unit: mm

2-spot welds

3-spot welds

MIG Plug weld

( For 3 panels plug weld method )

MIG seam weld/  
Point weld

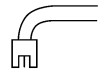

WIIA0866E

# BODY REPAIR

## REAR FENDER EXTENSION

### Service Joint

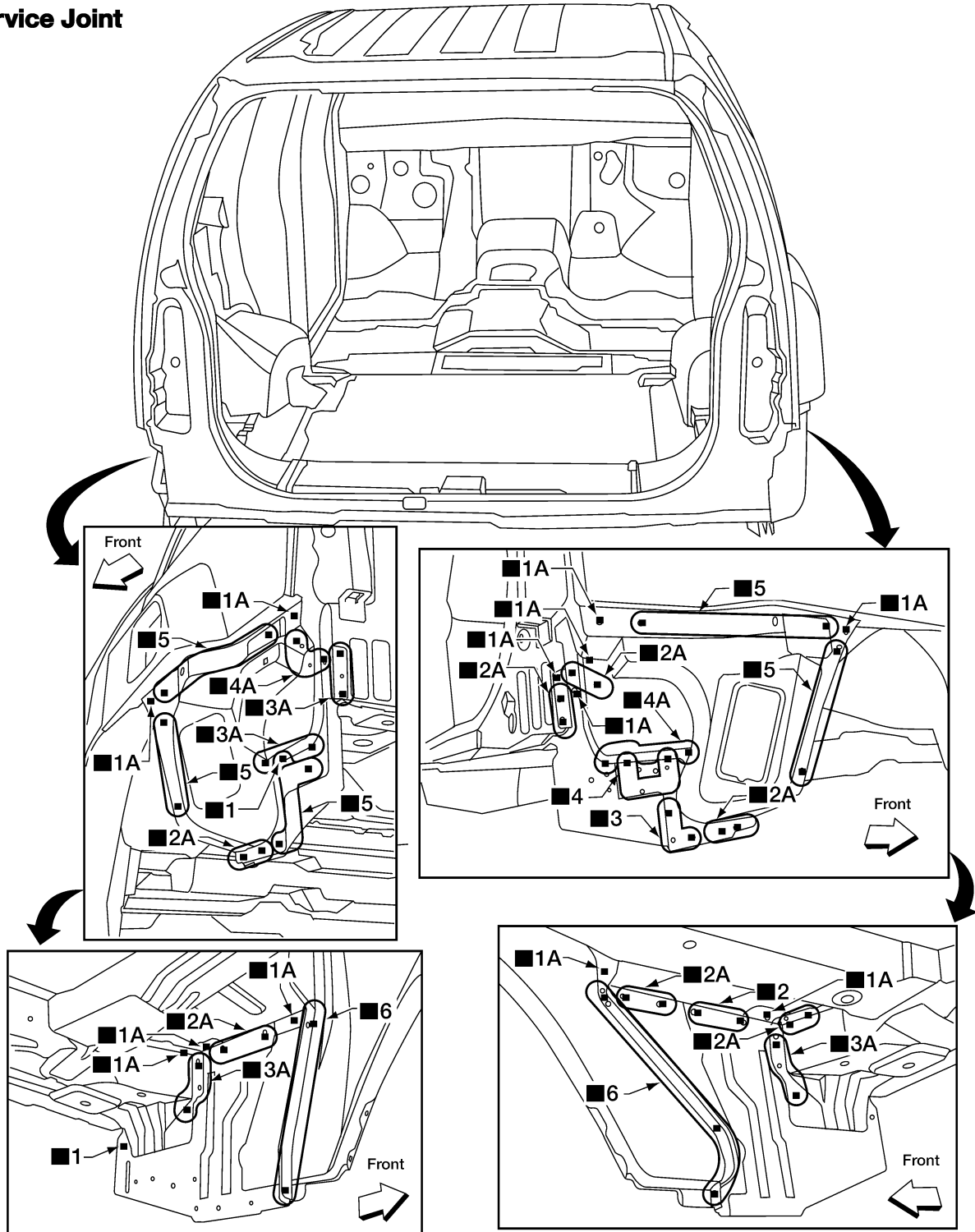

2-spot welds

3-spot welds

MIG Plug weld

( For 3 panels plug weld method )

MIG seam weld/  
Point weld

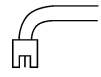

LIA2127E

# BODY REPAIR

## MAIN BACK PILLAR

### Service Joint

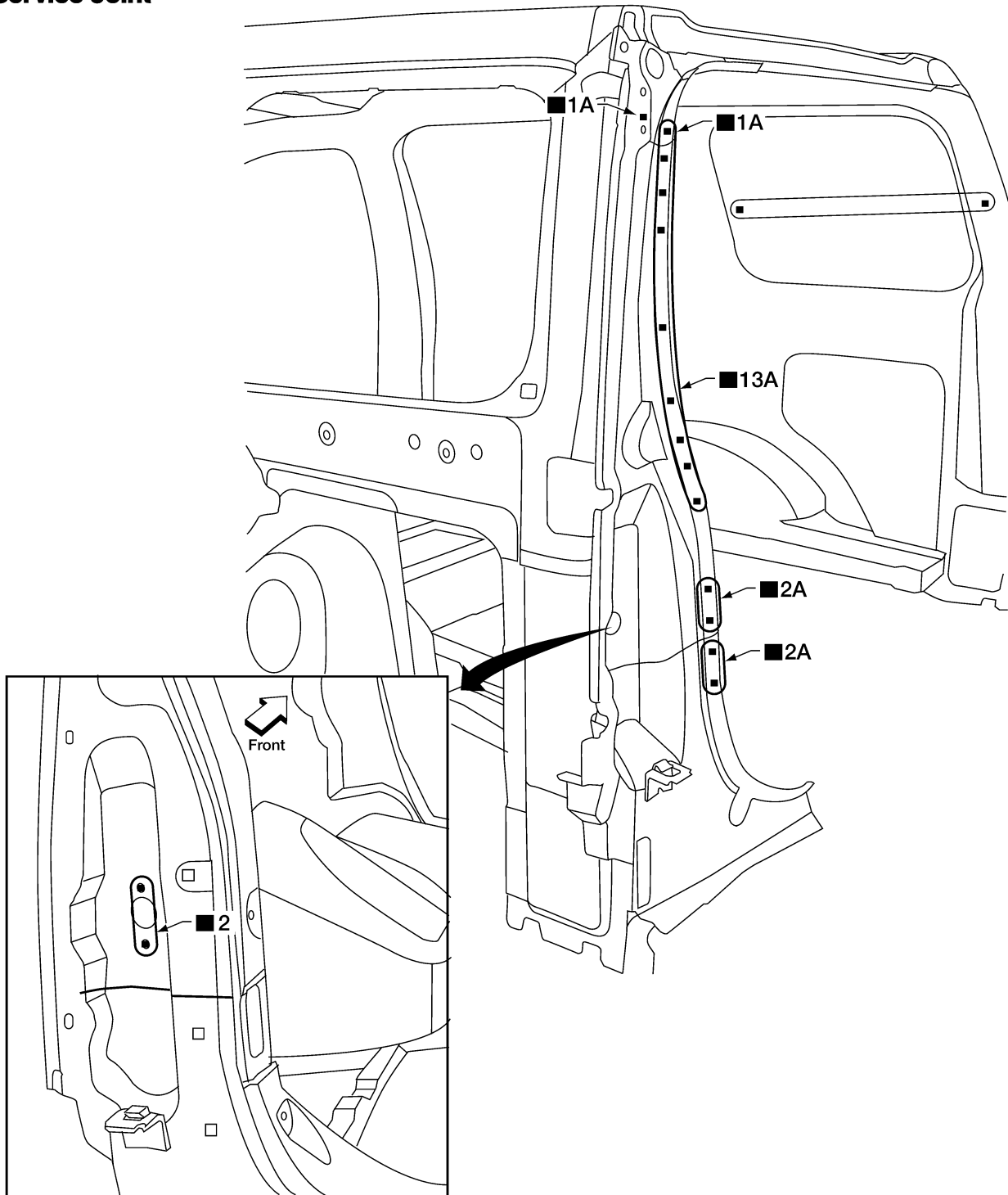

2-spot welds

3-spot welds

MIG Plug weld

For 3 panels plug weld method

MIG seam weld/  
Point weld



W11A0867E



# BODY REPAIR

## REAR FLOOR REAR

### Service Joint

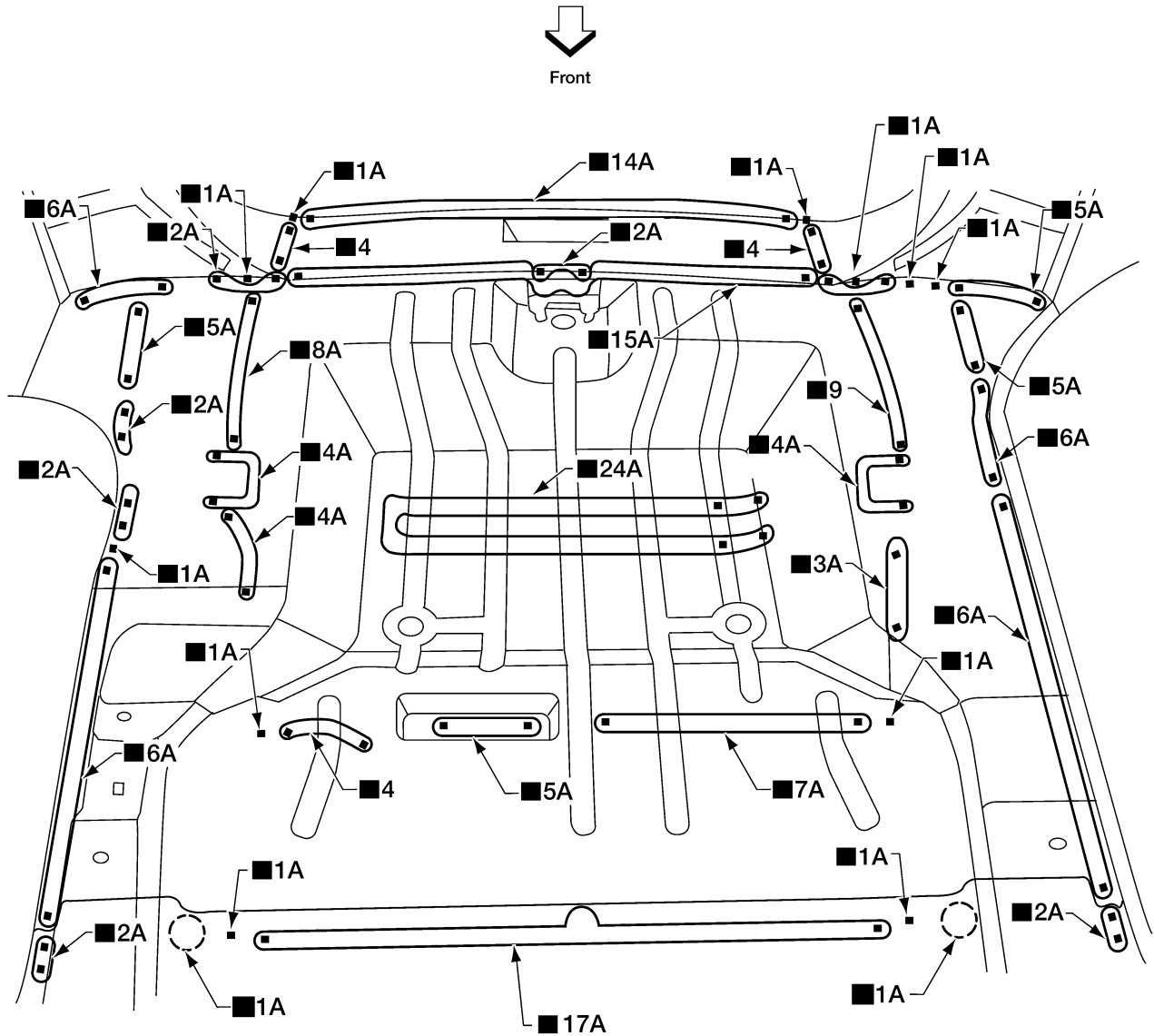

○ 3 panel plug weld below front floor

2-spot welds

3-spot welds

MIG Plug weld

( For 3 panels plug weld method )

MIG seam weld/  
Point weld

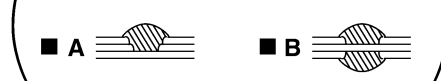
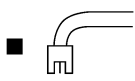
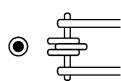
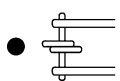

LIA2128E

# BODY REPAIR

## REAR CROSSMEMBER Rear Floor Upper Extensions

### Service Joint

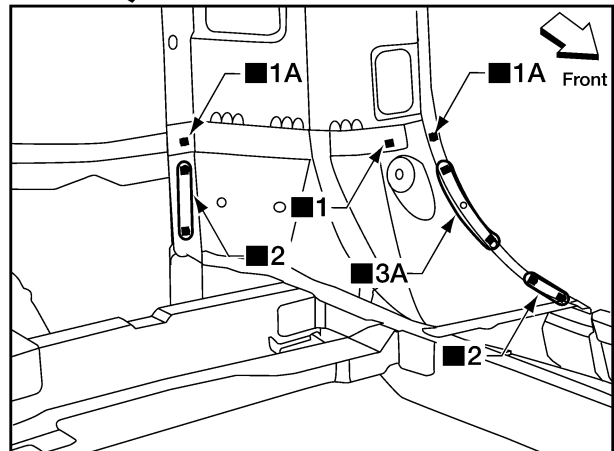
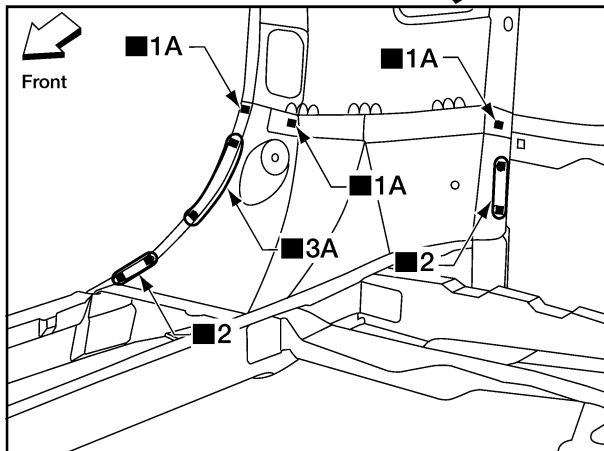
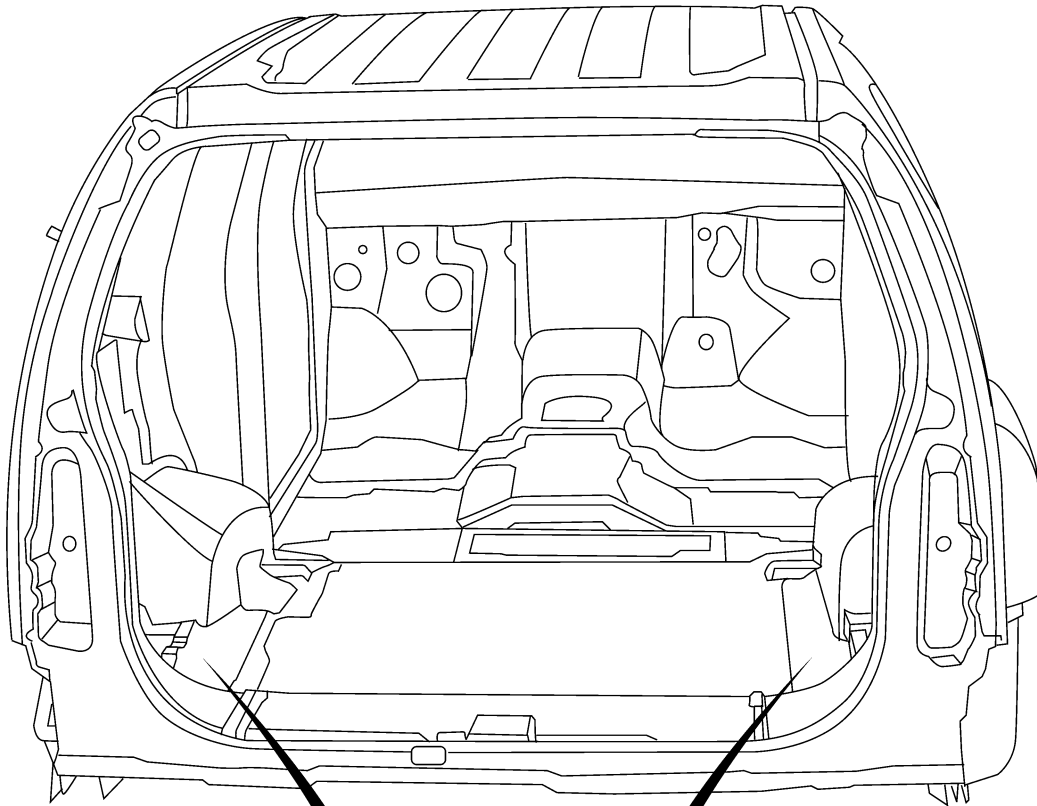

2-spot welds

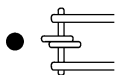

3-spot welds

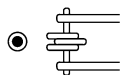

MIG Plug weld



( For 3 panels plug weld method )



MIG seam weld/  
Point weld



WI1A0868E

# BODY REPAIR

## Crossmember

### Service Joint

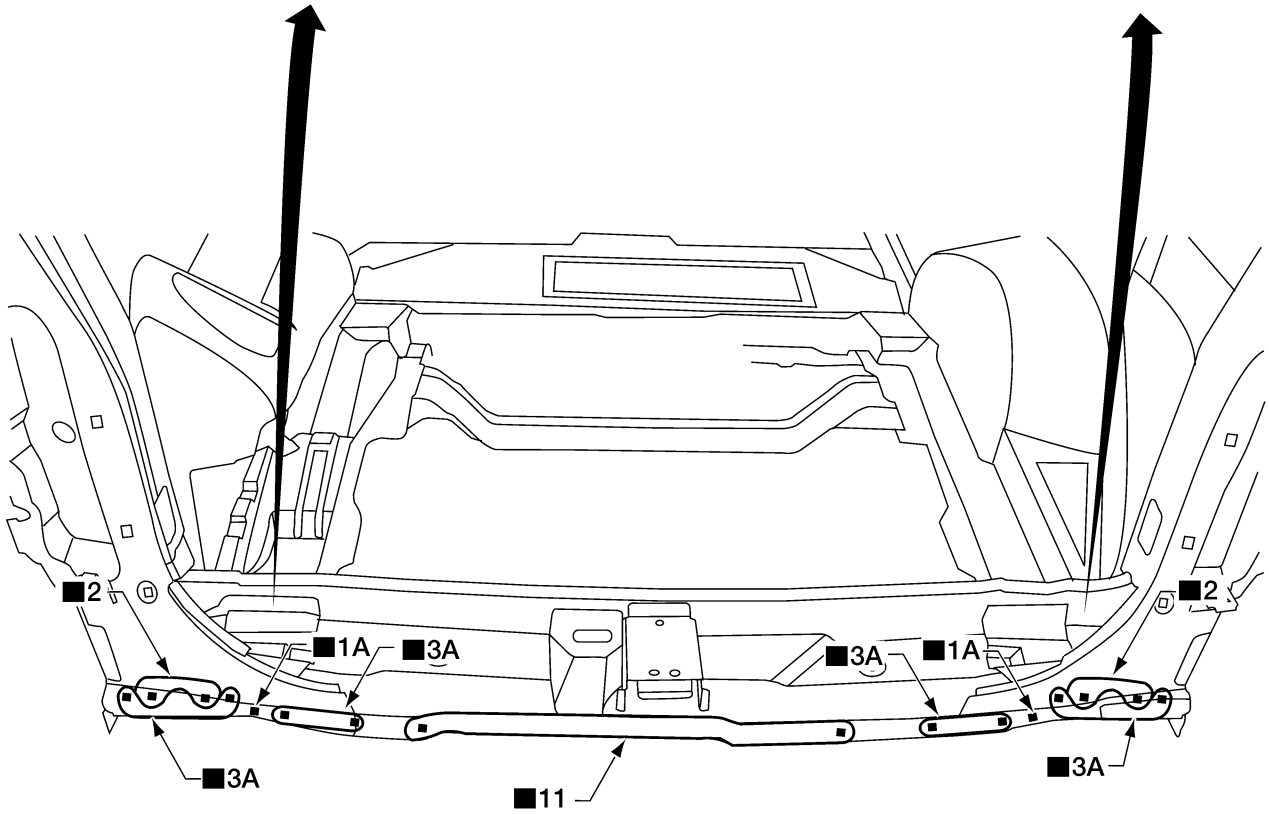
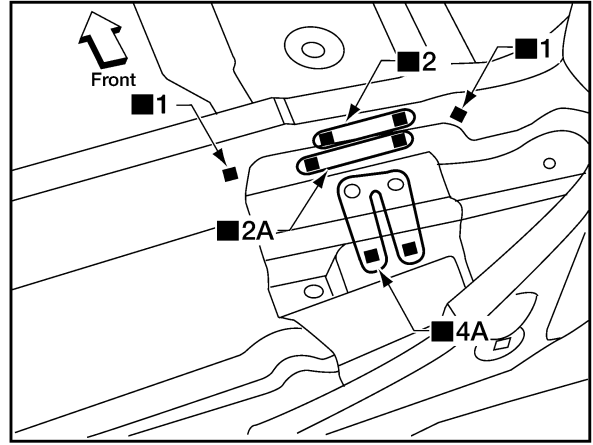
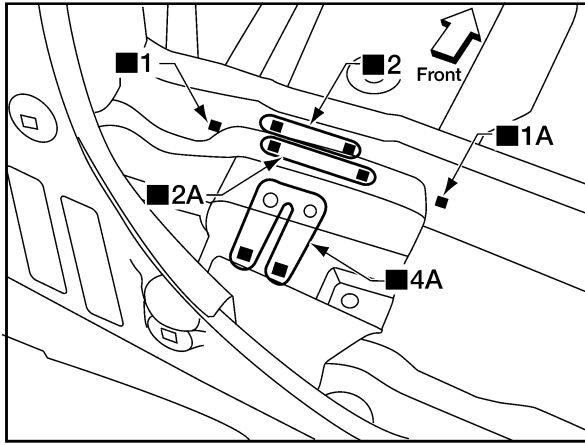

2-spot welds

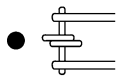

3-spot welds

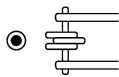

MIG Plug weld

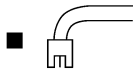

( For 3 panels plug weld method )



MIG seam weld/  
Point weld



WIHA0869E

A  
B  
C  
D  
E  
F  
G  
H  
BL  
J  
K  
L  
M

## BODY REPAIR

---

### CRUSH HORN

**CAUTION:**

When replacing a damaged crush horn on N50 model, do not choose partial replacement method, such as cutting and butt-joint welding the crush horn.

# BODY REPAIR

Be sure to replace the entire crush horn when the crush horn has damage at the back of the body mounting bracket.

## Service Joint

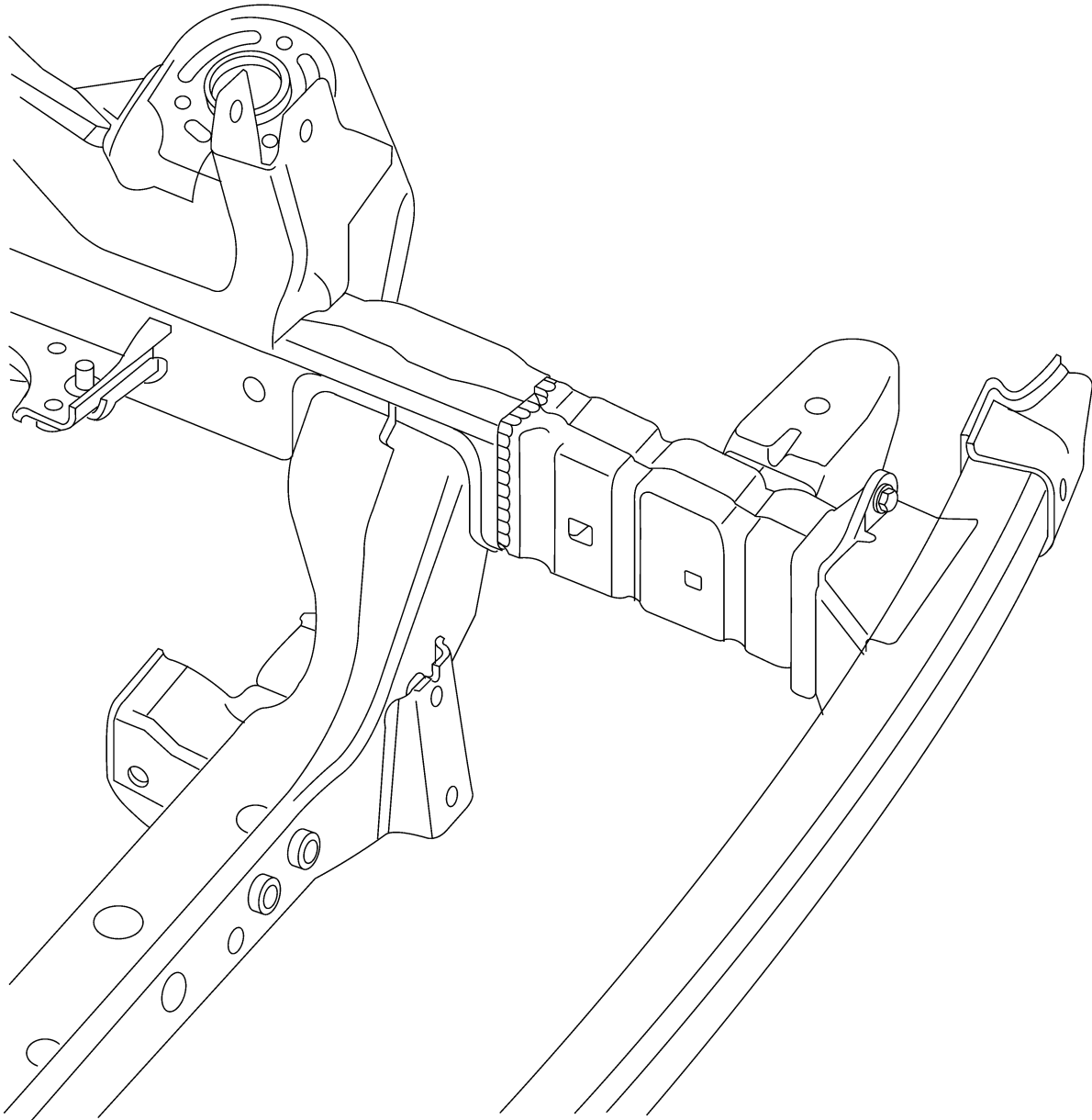

A  
B  
C  
D  
E  
F  
G  
H  
BL  
J  
K  
L  
M

2-spot welds

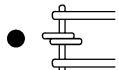

3-spot welds

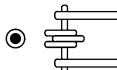

MIG Plug weld

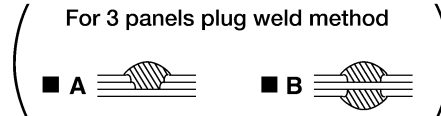
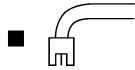

MIG seam weld/  
Point weld



LIIA2148E

# BODY REPAIR

---