

SECTION **LU**
ENGINE LUBRICATION SYSTEM

A

LU

C

D

E

CONTENTS

PRECAUTIONS	2	OIL COOLER	10	F
Precautions for Liquid Gasket	2	Removal and Installation	10	
LIQUID GASKET APPLICATION PROCEDURE.....	2	REMOVAL	10	G
PREPARATION	3	INSPECTION AFTER REMOVAL	11	
Special Service Tools	3	INSTALLATION	11	H
Commercial Service Tools	3	INSPECTION AFTER INSTALLATION	11	
LUBRICATION SYSTEM	4	OIL PUMP	12	I
Lubrication Circuit	4	Removal and Installation	12	
System Chart	5	REMOVAL	12	J
ENGINE OIL	6	INSTALLATION	12	
Inspection	6	INSPECTION AFTER INSTALLATION	12	K
ENGINE OIL LEVEL	6	Disassembly and Assembly	12	
ENGINE OIL APPEARANCE	6	DISASSEMBLY	12	L
ENGINE OIL LEAKAGE	6	INSPECTION AFTER DISASSEMBLY	13	
OIL PRESSURE CHECK	7	ASSEMBLY	14	M
Changing Engine Oil	8	SERVICE DATA AND SPECIFICATIONS (SDS)	15	
OIL FILTER	9	Standard and Limit	15	
Removal and Installation	9	OIL PRESSURE	15	
REMOVAL	9	OIL CAPACITY (APPROXIMATE)	15	
INSTALLATION	9	OIL PUMP	15	
INSPECTION AFTER INSTALLATION	9	REGULATOR VALVE	15	

PRECAUTIONS

PRECAUTIONS

PFP:00001

EBS00NLJ

Precautions for Liquid Gasket LIQUID GASKET APPLICATION PROCEDURE

1. Remove old liquid gasket adhering to the liquid gasket application surface and the mating surface, Using scraper.
 - Remove liquid gasket completely from the groove of the liquid gasket application surface, bolts, and bolt holes.
2. Thoroughly clean the mating surfaces and remove adhering moisture, grease and foreign materials.

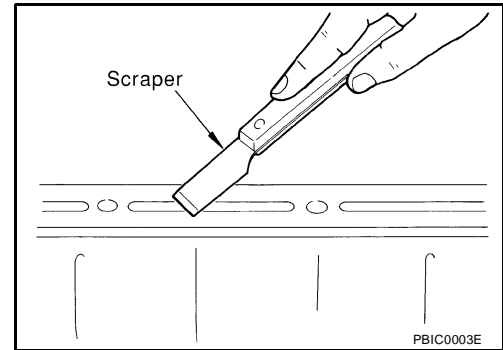

3. Attach liquid gasket tube to Tool.

Tool number : WS39930000 (—)

Use Genuine RTV Silicone Sealant or equivalent. Refer to [GI-48, "Recommended Chemical Products and Sealants"](#).

4. Apply liquid gasket without breaks to the specified location with the specified dimensions.
 - If there is a groove for the liquid gasket application, apply liquid gasket to the groove.

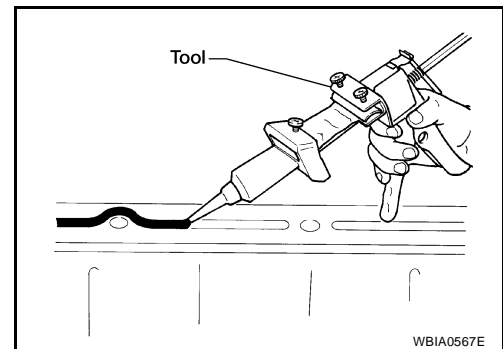

- As for the bolt holes, normally apply liquid gasket inside the holes. Occasionally, it should be applied outside the holes. Make sure to read the text of service manual.
- Within five minutes of liquid gasket application, install the mating component.
- If liquid gasket protrudes, wipe it off immediately.
- Do not retighten nuts or bolts after the installation.
- After 30 minutes or more have passed from the installation, fill engine oil and engine coolant.

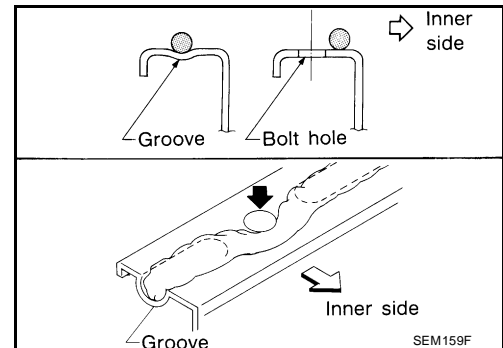

CAUTION:

If there are specific instructions in this manual, observe them.

PREPARATION

PREPARATION

PF0:00002

Special Service Tools

EBS00NLK

The actual shapes of Kent-Moore tools may differ from those of special service tools illustrated here.

Tool number (Kent-Moore No.) Tool name	Description
ST25051001 (J-25695-1) Oil pressure gauge	Measuring oil pressure Maximum measuring range: 2,452 kPa (25 kg/cm² , 356 psi)
ST25052000 (J-25695-2) Hose	Adapting oil pressure gauge to oil pan (upper)
KV10115801 (J-38956) Oil filter wrench	Removing oil filter a: 64.3 mm (2.531 in)
WS39930000 (—) Tube presser	Pressing the tube of liquid gasket

Commercial Service Tools

EBS00NLL

Tool name	Description
Power tool	Loosening nuts and bolts
Deep socket	Removing and installing oil pressure sensor a: 24 mm (0.94 in)

LUBRICATION SYSTEM

PF15010

LUBRICATION SYSTEM

Lubrication Circuit

EBS00NLM

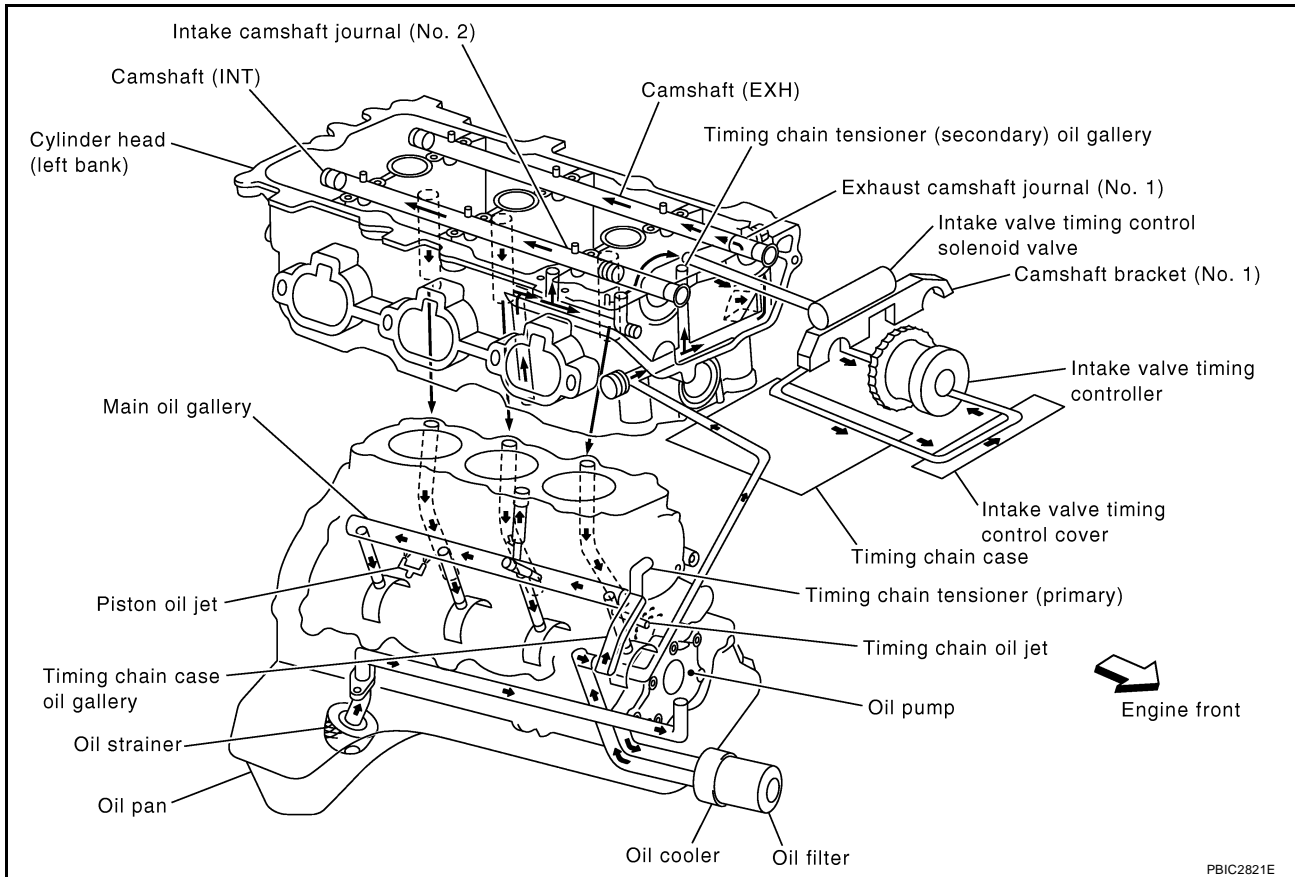

LUBRICATION SYSTEM

System Chart

EBS00NLN

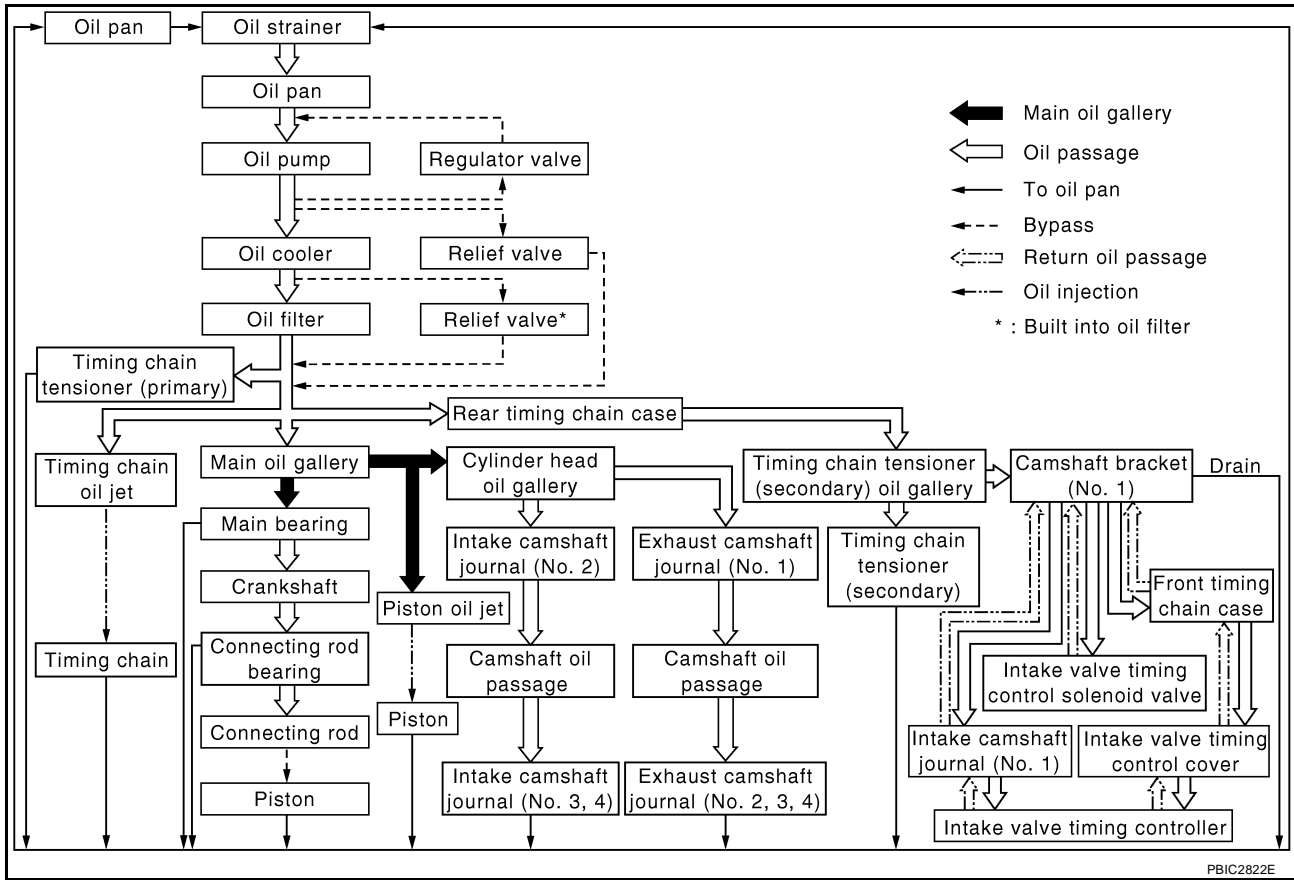

A
LU
 C
 D
 E
 F
 G
 H
 I
 J
 K
 L
 M

ENGINE OIL

ENGINE OIL

PFP:KLA92

Inspection ENGINE OIL LEVEL

EBS00NLO

Before starting the engine make sure the vehicle is parked on a flat and level surface, then check the oil level. If the engine is already running, turn it off and allow 10 minutes before checking.

1. Pull out oil level gauge and wipe it clean.
2. Insert oil level gauge and make sure the engine oil level is within the range as indicated on gauge.
3. If the engine oil is out of range, add oil as necessary.

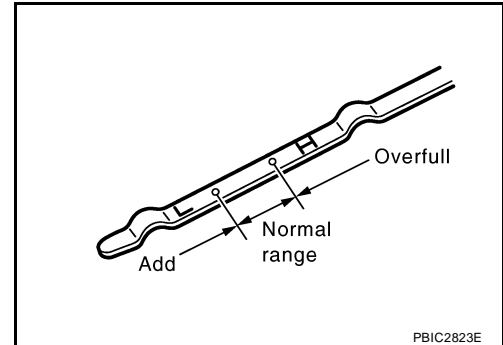

ENGINE OIL APPEARANCE

- Check engine oil for white milky or excessive contamination.
- If engine oil becomes milky, it is highly probable that it is contaminated with engine coolant. Repair or replace damaged parts.

ENGINE OIL LEAKAGE

Check for oil leakage around the following areas:

- Oil pans (lower and upper)
- Oil pan drain plug
- Oil pressure sensor
- Oil filter
- Oil cooler
- Water pump cover
- Chain tensioner cover
- Intake valve timing control cover and intake valve timing control solenoid valve
- Mating surface between cylinder block and cylinder head
- Mating surface between lower cylinder block and cylinder block
- Mating surface between cylinder head and rocker cover
- Mating surface between front timing chain case and rear timing chain case
- Mating surface between rear timing chain case and cylinder head
- Mating surface between rear timing chain case and cylinder block
- Mating surface between rear timing chain case and lower cylinder block
- Mating surface between rear timing chain case and oil pan (upper)
- Crankshaft oil seals (front and rear)
- Oil level gauge guide
- Camshaft position sensor (PHASE)

ENGINE OIL

OIL PRESSURE CHECK

WARNING:

- Be careful not to burn yourself, as engine oil may be hot.
- Oil pressure check should be done in "Parking position" (A/T models).

1. Check engine oil level. Refer to [LU-6, "ENGINE OIL LEVEL"](#).
2. Remove undercover with power tool.
3. Disconnect oil pressure sensor harness connector.
4. Disconnect harness connector at oil pressure sensor, and remove oil pressure sensor.

CAUTION:

Do not drop or shock oil pressure sensor.

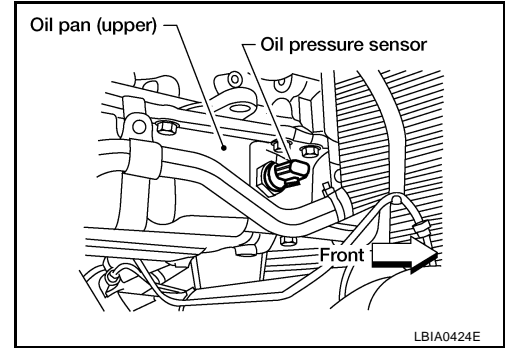

5. Install Tools.

Tool numbers : ST25051001 (J-25695-1)
: ST25052000 (J-25695-2)

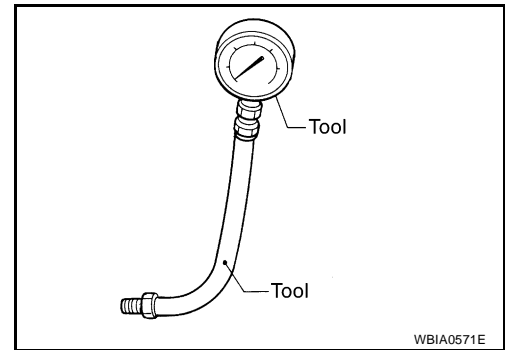

6. Start engine and warm it up to normal operating temperature.
7. Check oil pressure with engine running under no-load.

NOTE:

When engine oil temperature is low, engine oil pressure becomes high.

Engine oil pressure [Engine oil temperature at 80°C (176°F)]

Engine speed rpm	Approximate discharge pressure kPa (kg/cm ² , psi)
Idle speed	More than 98 (1.0, 14)
2,000	More than 294 (3.0, 43)

If difference is extreme, check oil passage and oil pump for oil leaks.

8. After the inspections, install oil pressure sensor as follows:
 - a. Remove old liquid gasket adhering to oil pressure sensor and engine.
 - b. Apply liquid gasket and tighten oil pressure sensor to the specification.
Use Genuine RTV Silicone Sealant or equivalent. Refer to [GI-48, "Recommended Chemical Products and Sealants"](#).

Oil pressure sensor torque : 14.7 N·m (1.5 kg·m, 11 ft·lb)

- c. After warming up engine, make sure there is no leakage of engine oil with running engine.

ENGINE OIL

EBS00NLP

Changing Engine Oil

WARNING:

- Be careful not to burn yourself, as engine oil may be hot.
 - Prolonged and repeated contact with used engine oil may cause skin cancer; try to avoid direct skin contact with used engine oil. If skin contact is made, wash thoroughly with soap or hand cleaner as soon as possible.
1. Warm up engine, put vehicle on flat and level surface then check for engine oil leakage from engine components. Refer to [LU-6, "ENGINE OIL LEAKAGE"](#) .
 2. Stop engine and wait for 10 minutes.
 3. Loosen oil filler cap and then remove drain plug.
 4. Drain engine oil.
 5. Install drain plug with new washer. Refer to [EM-27, "OIL PAN AND OIL STRAINER"](#) .

CAUTION:

Be sure to clean drain plug and install with new washer.

Oil pan drain plug : 34.3 N-m (3.5 kg-m, 25ft-lb)

6. Refill with new engine oil.
Engine oil specification and viscosity:
Refer to [MA-11, "RECOMMENDED FLUIDS AND LUBRICANTS"](#) .

Engine oil capacity (Approximate):

Unit: ℓ (US qt, Imp qt)

Drain and refill	With oil filter change	5.1 (5 3/8, 4-1/2)
	Without oil filter change	4.8 (5-1/8, 4-1/4)
Dry engine (Overhaul)		6.3 (6-5/8, 5-1/2)

CAUTION:

- When filling engine oil, do not pull out oil level gauge.
 - The refill capacity depends on the engine oil temperature and drain time. Use these specifications for reference only.
 - Always use oil level gauge to determine the proper amount of engine oil in engine.
7. Warm up engine and check area around drain plug and oil filter for oil leakage.
 8. Stop engine and wait for 10 minutes.
 9. Check the engine oil level. Refer to [LU-6, "ENGINE OIL LEVEL"](#) .

OIL FILTER

PF15208

EBS00NLQ

OIL FILTER

Removal and Installation

REMOVAL

1. Remove oil filter access in undercover.
2. Remove the oil filter using Tool.

Tool number : KV10115801 (J-38956)

CAUTION:

- Oil filter is provided with relief valve. Use Genuine NISSAN Oil Filter or equivalent.
- Be careful not to get burned when engine and engine oil may be hot.
- When removing, prepare a shop cloth to absorb any engine oil leakage or spillage.
- Do not allow engine oil to adhere to drive belts.
- Completely wipe off any engine oil that adheres to engine and vehicle.

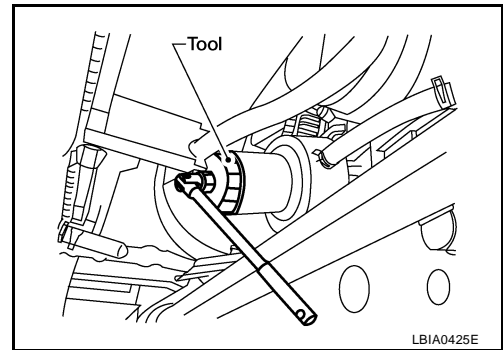

INSTALLATION

1. Remove foreign materials adhering to oil filter installation surface.
2. Apply engine oil to the oil seal circumference of new oil filter.

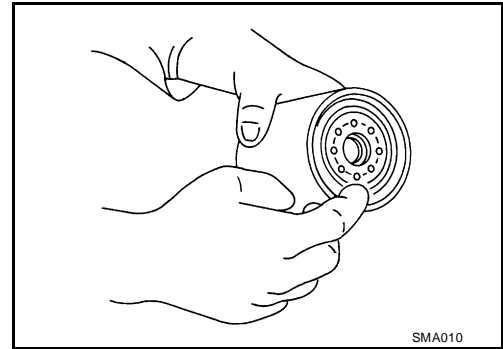

3. Screw oil filter manually until it touches the installation surface, then tighten it by 2/3 turn. Or tighten to specification.

Oil filter: : 17.7 N·m (1.8 kg·m, 13 ft·lb)

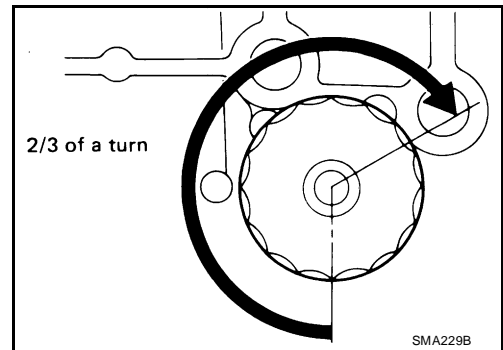

INSPECTION AFTER INSTALLATION

1. Check the engine oil level. Refer to [LU-6, "ENGINE OIL LEVEL"](#).
2. Start engine, and check there are no leaks of engine oil.
3. Stop engine and wait for 10 minutes.
4. Check the engine oil level and add engine oil. Refer to [LU-6, "ENGINE OIL LEVEL"](#).

A
LU
C
D
E
F
G
H
I
J
K
L
M

OIL COOLER

PF21305

OIL COOLER

Removal and Installation

EBS00NLR

SEC. 150•211•213

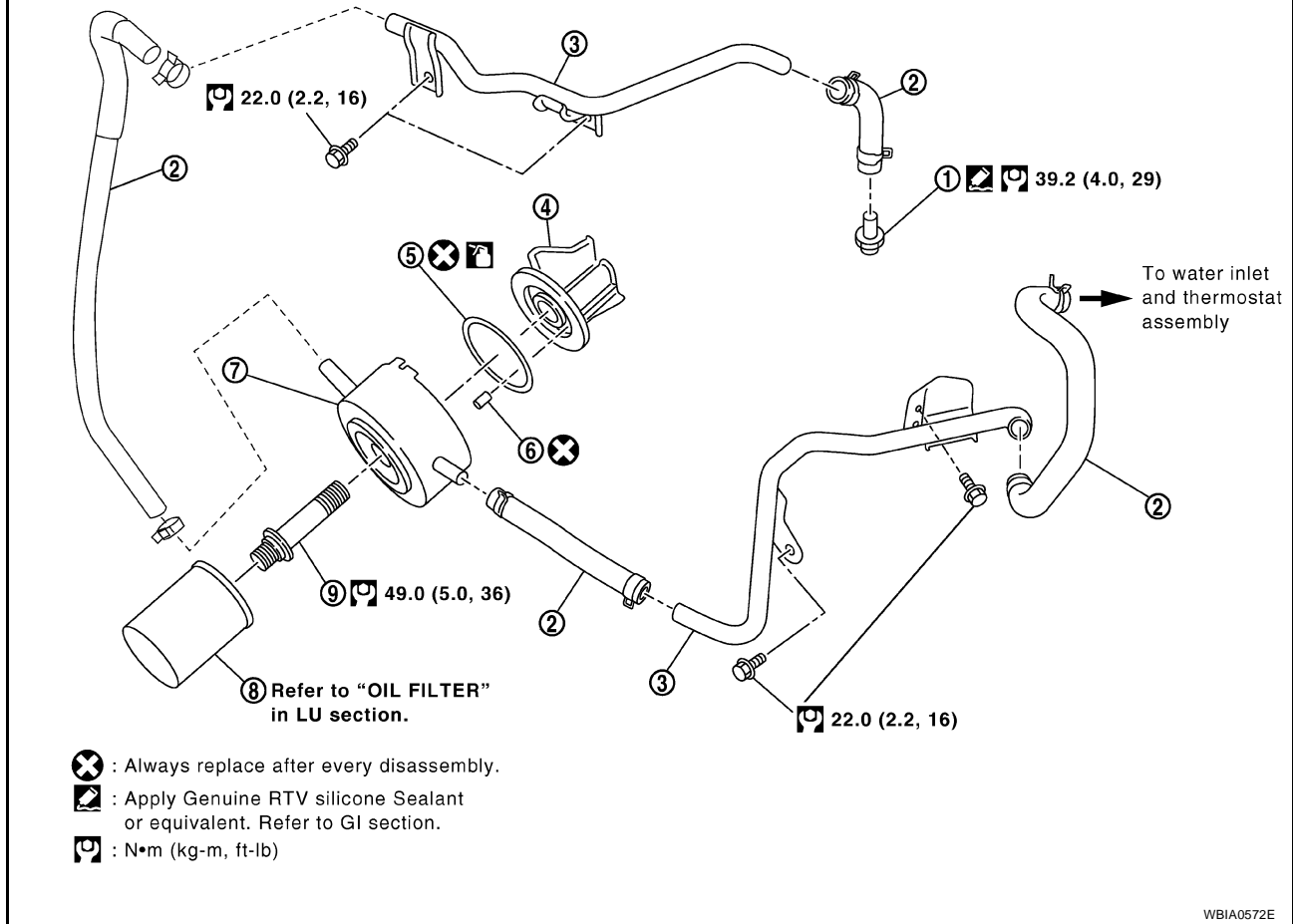

- | | | |
|-------------------------------|---------------|-------------------|
| 1. Water connector | 2. Water hose | 3. Water pipe |
| 4. Oil pan (upper) front side | 5. O-ring | 6. Relief valve |
| 7. Oil cooler | 8. Oil filter | 9. Connector bolt |

WARNING:

Be careful not to get burn yourself, as engine oil and engine coolant are hot.

REMOVAL

NOTE:

When removing oil cooler only, step 1 is unnecessary.

1. Drain engine coolant from radiator and cylinder block. Refer to [CO-10, "ENGINE COOLANT"](#) and [EM-109, "DISASSEMBLY"](#).

NOTE:

Perform this step when removing water pipes.

2. Remove oil filter. Refer to [LU-9, "Removal and Installation"](#).

CAUTION:

Do not spill engine oil on drive belts.

3. Disconnect water hoses from oil cooler.

- When removing oil cooler only, pinching water hoses near oil cooler to prevent engine coolant spilling.

CAUTION:

- Perform this step when engine is cold.
- Do not spill engine coolant on drive belts.

4. Remove connector bolt, and remove oil cooler.

OIL COOLER

CAUTION:

Do not spill engine oil to rubber parts such as drive belts and engine mounting insulator.

5. Remove water pipes, as necessary.

INSPECTION AFTER REMOVAL

Oil Cooler

Check oil cooler for cracks. Check oil cooler for clogging by blowing through engine coolant inlet. If necessary, replace oil cooler.

Relief Valve

Check relief valve for movement, cracks and breaks by pushing the ball. If replacement is necessary, remove relief valve by prying it out using a suitable tool. Install a new relief valve in place by tapping it in.

INSTALLATION

Installation is in the reverse order of removal, paying attention to the following.

- Make sure that no foreign objects are adhering to the installation planes of oil cooler and oil pan (upper).
- Tighten connector bolt after aligning cutout on oil cooler with protrusion on oil pan (upper) side.

Connector bolt torque : 49 N-m (5.0 kg-m, 36 ft-lb)

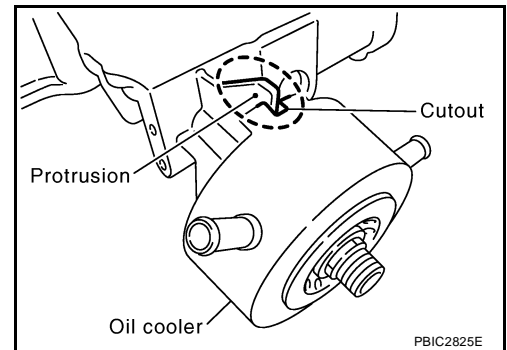

INSPECTION AFTER INSTALLATION

1. Check the engine oil level and the engine coolant level, and add engine oil and engine coolant. Refer to [LU-6, "ENGINE OIL LEVEL"](#) and [CO-10, "ENGINE COOLANT"](#).
2. Start engine, and make sure that there are no leaks of engine oil or engine coolant.
3. Stop engine and wait for 10 minutes.
4. Check the engine oil level and the engine coolant level again. Refer to [LU-6, "ENGINE OIL LEVEL"](#) and [CO-10, "ENGINE COOLANT"](#).

OIL PUMP

PF15010

OIL PUMP

Removal and Installation

EBS00NLS

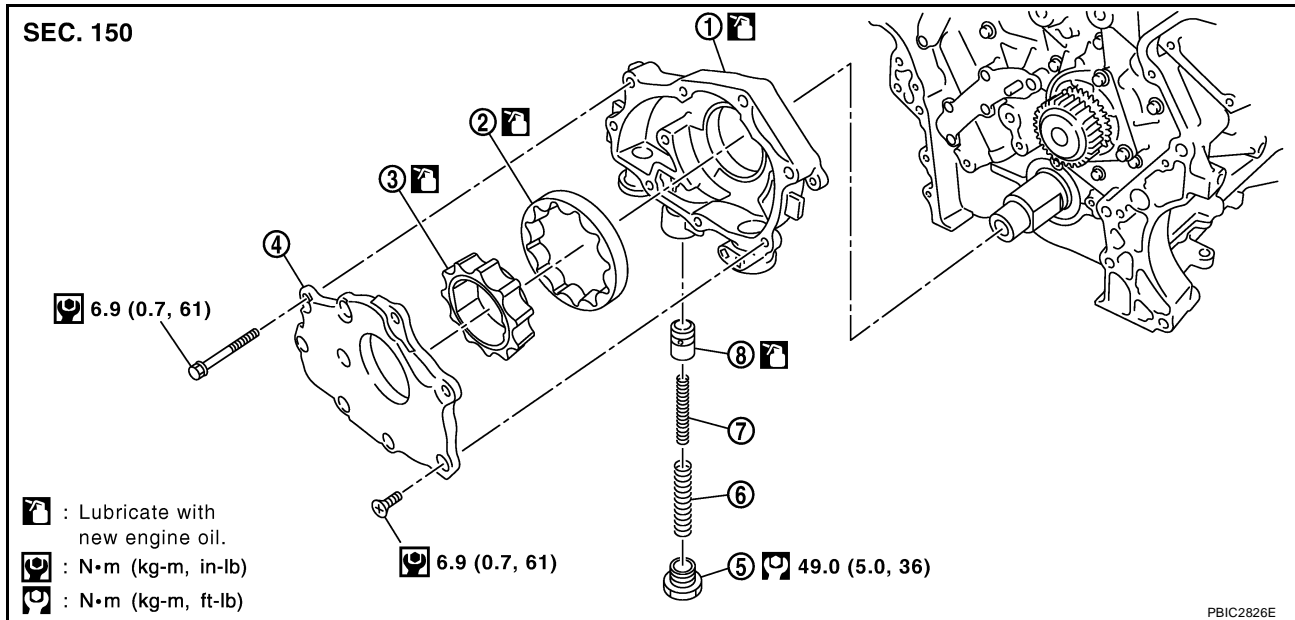

- | | | |
|---------------------------|-------------------------|---------------------------|
| 1. Oil pump body | 2. Oil pump outer rotor | 3. Oil pump inner rotor |
| 4. Oil pump cover | 5. Regulator valve plug | 6. Regulator valve spring |
| 7. Regulator valve spring | 8. Regulator valve | |

REMOVAL

1. Remove oil pans (lower and upper). Refer to [EM-27, "Removal and Installation"](#) .
2. Remove front timing chain case and timing chain (primary). Refer to [EM-55, "Removal and Installation"](#) .
3. Remove oil pump assembly.

INSTALLATION

Installation is in the reverse order of removal, paying attention to the following.

- When installing, align crankshaft flat faces with inner rotor flat faces.

INSPECTION AFTER INSTALLATION

1. Check the engine oil level. Refer to [LU-6, "ENGINE OIL LEVEL"](#) .
2. Start engine, and check there are no leaks of engine oil.
3. Stop engine and wait for 10 minutes.
4. Check the engine oil level and add engine oil. Refer to [LU-6, "ENGINE OIL LEVEL"](#) .

Disassembly and Assembly

DISASSEMBLY

EBS00NLT

1. Remove oil pump cover.
2. Remove oil pump inner rotor and oil pump outer rotor from oil pump body.
3. After removing regulator valve plug, remove regulator valve springs and regulator valve.

OIL PUMP

INSPECTION AFTER DISASSEMBLY

Oil Pump Clearance

- Measure the clearance with feeler gauge.
 - Clearance between oil pump outer rotor and oil pump body (position "1")
Standard : 0.120 - 0.195 mm (0.0047 - 0.0077 in)
 - Tip clearance between oil pump inner rotor and oil pump outer rotor (position "2")
Standard : 0.06 - 0.16 mm (0.0024 - 0.0063 in)

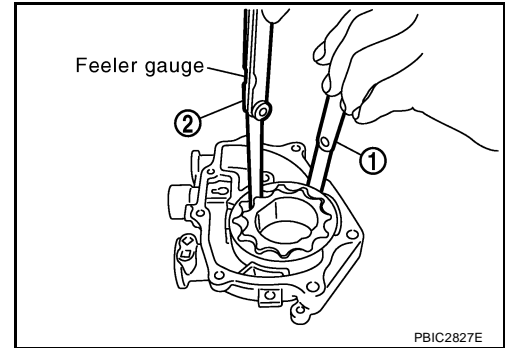

- Measure the clearance with feeler gauge and straightedge.
 - Side clearance between oil pump inner rotor and oil pump body (position "3")
Standard : 0.030 - 0.070 mm (0.0012 - 0.0028 in)
 - Side clearance between oil pump outer rotor and oil pump body (position "4")
Standard : 0.05 - 0.09 mm (0.0020 - 0.0035 in)

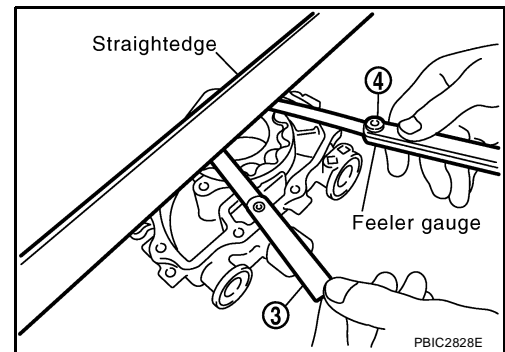

- Calculate the clearance between oil pump inner rotor and oil pump body as follows:

OIL PUMP BODY INNER DIAMETER

- Measure the inner diameter of oil pump body with inside micrometer. (position "5")

OIL PUMP INNER ROTOR OUTER DIAMETER

- Measure the outer diameter of protruded portion of oil pump inner rotor with micrometer. (position "6")

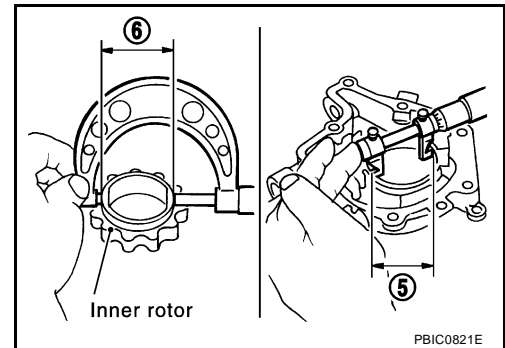

OIL PUMP INNER ROTOR TO OIL PUMP BODY CLEARANCE

- (Clearance) = (Oil pump body inner diameter) – (Oil pump inner rotor outer diameter)
Standard : 0.045 - 0.091 mm (0.0018 - 0.0036 in)

- If measured/calculated values are out of the standard, replace oil pump assembly.

OIL PUMP

Regulator Valve Clearance

(Clearance) = (Valve hole diameter) – (Regulator valve outer diameter)

Standard : 0.025 - 0.070 mm (0.0010 - 0.0028 in)

- If the calculated value is out of the standard, replace oil pump assembly.

CAUTION:

- Coat regulator valve with engine oil.
- Make sure that it falls smoothly into valve hole by its own weight.

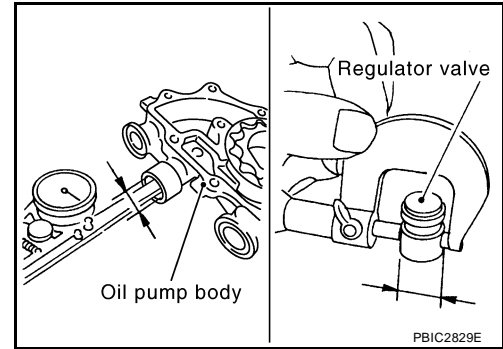

ASSEMBLY

Note the following, and assemble in the reverse order of disassembly.

- Install oil pump inner rotor with the groove faced and oil pump outer rotor with the punch mark to oil pump cover side.

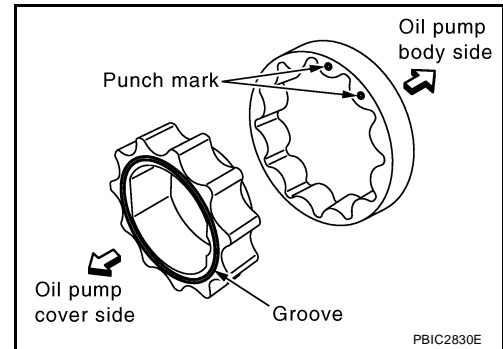

SERVICE DATA AND SPECIFICATIONS (SDS)

SERVICE DATA AND SPECIFICATIONS (SDS)

PF0:00030

Standard and Limit OIL PRESSURE

EBS00NLU

Engine speed rpm	Approximate discharge pressure* kPa (kg/cm ² , psi)
Idle speed	More than 98 (1.0, 14)
2,000	More than 294 (3.0, 43)

*: Engine oil temperature at 80°C (176°F)

OIL CAPACITY (APPROXIMATE)

Unit: ℓ (US qt, Imp qt)

Drain and refill	With oil filter change	5.1 (5-3/8, 4-1/2)
	Without oil filter change	4.8 (5-1/8, 4-1/4)
Dry engine (Overhaul)		6.3 (6-5/8, 5-1/2)

OIL PUMP

Unit: mm (in)

Body to outer rotor radial clearance	0.120 - 0.195 (0.0047 - 0.0077)
Inner rotor to outer rotor tip clearance	0.06 - 0.16 (0.0024 - 0.0063)
Body to inner rotor side clearance	0.030 - 0.070 (0.0012 - 0.0028)
Body to outer rotor side clearance	0.05 - 0.09 (0.0020 - 0.0035)
Inner rotor to brazed portion of housing clearance	0.045 - 0.091 (0.0018 - 0.0036)

REGULATOR VALVE

Unit: mm (in)

Regulator valve to oil pump body clearance	0.025 - 0.070 (0.0010 - 0.0028)
--	---------------------------------

SERVICE DATA AND SPECIFICATIONS (SDS)
