

SECTION MA
MAINTENANCE

A
B
C

CONTENTS

PRECAUTIONS	3	INSTALLATION	20	F
Precautions for Supplemental Restraint System (SRS) "AIR BAG" and "SEAT BELT PRE-TENSIONER"	3	Checking EVAP Vapor Lines	20	
PREPARATION	4	CHASSIS AND BODY MAINTENANCE	21	G
Special Service Tools	4	Changing the In-cabin Microfilter	21	
Commercial Service Tool	4	Checking the Exhaust System	22	
GENERAL MAINTENANCE	5	Checking the Automatic Transmission Fluid (ATF)..	22	
General Maintenance	5	Changing the Automatic Transmission Fluid (ATF)..	24	H
PERIODIC MAINTENANCE	7	Checking the Manual Transmission Fluid (MTF) ...	24	
Introduction of Periodic Maintenance	7	OIL LEAKAGE AND OIL LEVEL	24	
Schedule 1	7	Changing the Manual Transmission Fluid (MTF) ...	25	I
EMISSION CONTROL SYSTEM MAINTENANCE	7	DRAINING	25	
CHASSIS AND BODY MAINTENANCE	8	FILLING	25	
Schedule 2	9	Checking Transfer Fluid	25	J
EMISSION CONTROL SYSTEM MAINTENANCE	9	FLUID LEAKAGE AND FLUID LEVEL	25	
CHASSIS AND BODY MAINTENANCE	10	Changing Transfer Fluid	25	
RECOMMENDED FLUIDS AND LUBRICANTS	11	DRAINING	25	
Fluids and Lubricants	11	FILLING	26	K
SAE Viscosity Number	12	Checking Propeller Shaft	26	
GASOLINE ENGINE OIL	12	Checking Front Final Drive Oil	26	
ANTI-FREEZE COOLANT MIXTURE RATIO ...	12	OIL LEAKAGE AND OIL LEVEL	26	
ENGINE MAINTENANCE	13	Changing Front Final Drive Oil	26	MA
Checking Drive Belts	13	DRAINING	26	
DRIVE BELT TENSION ADJUSTMENT	13	FILLING	27	
Changing Engine Coolant	13	Checking Rear Final Drive Oil	27	M
DRAINING ENGINE COOLANT	13	OIL LEAKAGE AND OIL LEVEL	27	
REFILLING ENGINE COOLANT	14	Changing Rear Final Drive Oil	27	
FLUSHING COOLING SYSTEM	16	DRAINING	27	
Checking Fuel Lines	16	FILLING	28	
Changing Fuel Filter	16	Balancing Wheels	28	
Changing Engine Air Cleaner Filter	17	WHEEL BALANCE ADJUSTMENT	28	
VISCOUS PAPER TYPE	17	Tire Rotation	30	
Changing Engine Oil	17	Checking Brake Fluid Level and Leaks	30	
Changing Oil Filter	18	Checking Brake Lines and Cables	30	
Changing Spark Plugs (Platinum - Tipped Type) ...	19	Checking Disc Brake	31	
REMOVAL	19	ROTOR	31	
INSPECTION AFTER REMOVAL	19	CALIPER	31	
		PAD	31	
		Checking Steering Gear and Linkage	31	
		STEERING GEAR	31	
		STEERING LINKAGE	31	

Checking Power Steering Fluid and Lines	32	PARTS	32
CHECKING FLUID LEVEL	32	FRONT DRIVE SHAFT	32
CHECKING LINES	32	Lubricating Locks, Hinges and Hood Latches	33
Checking Axle and Suspension Parts	32	Checking Seat Belts, Buckles, Retractors, Anchors	
FRONT AND REAR AXLE AND SUSPENSION		and Adjusters	34

PRECAUTIONS

PRECAUTIONS

PFP:00001

Precautions for Supplemental Restraint System (SRS) “AIR BAG” and “SEAT BELT PRE-TENSIONER”

ELS001HG

The Supplemental Restraint System such as “AIR BAG” and “SEAT BELT PRE-TENSIONER”, used along with a front seat belt, helps to reduce the risk or severity of injury to the driver and front passenger for certain types of collision. This system includes seat belt switch inputs and dual stage front air bag modules. The SRS system uses the seat belt switches to determine the front air bag deployment, and may only deploy one front air bag, depending on the severity of a collision and whether the front occupants are belted or unbelted. Information necessary to service the system safely is included in the SRS and SB section of this Service Manual.

WARNING:

- To avoid rendering the SRS inoperative, which could increase the risk of personal injury or death in the event of a collision which would result in air bag inflation, all maintenance must be performed by an authorized NISSAN/INFINITI dealer.
- Improper maintenance, including incorrect removal and installation of the SRS, can lead to personal injury caused by unintentional activation of the system. For removal of Spiral Cable and Air Bag Module, see the SRS section.
- Do not use electrical test equipment on any circuit related to the SRS unless instructed to in this Service Manual. SRS wiring harnesses can be identified by yellow and/or orange harnesses or harness connectors.

A
B
C
D
E
F
G
H
I
J
K
M

MA

PREPARATION

PFP:00002

PREPARATION

Special Service Tools

ELS001HH

The actual shapes of the Kent-Moore tools may differ from those of the special service tools illustrated here.

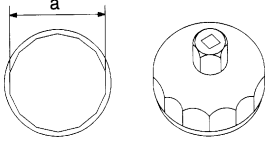
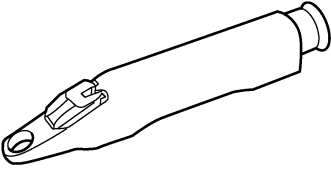
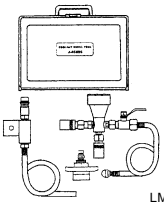
Tool number (Kent-Moore No.) Tool name		Description
KV10115801 (J-38956) Oil filter cap wrench	 <p style="text-align: center;">NT375</p>	Removing and installing oil filter a: 64.3 mm (2.531 in)
KV991J0010 (J-23688) Engine coolant refractometer	 <p style="text-align: center;">WBIA0539E</p>	Checking concentration of ethylene glycol in engine coolant
KV991J0070 (J-45695) Coolant refill tool	 <p style="text-align: center;">LMA053</p>	Filling cooling system

Commercial Service Tool

ELS001HI

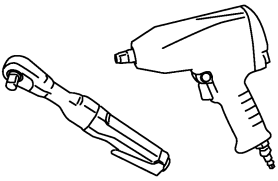
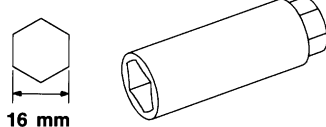
(Kent-Moore No.) Tool name		Description
Power tool	 <p style="text-align: center;">PBIC0190E</p>	Loosening bolts and nuts
Spark plug wrench	 <p style="text-align: center;">16 mm (0.63 in)</p> <p style="text-align: center;">S-NT047</p>	Removing and installing spark plug

GENERAL MAINTENANCE

GENERAL MAINTENANCE

PFP:00000

General Maintenance

ELS001HJ

General maintenance includes those items which should be checked during the normal day-to-day operation of the vehicle. They are essential if the vehicle is to continue operating properly. The owner can perform these checks and inspections or have their NISSAN dealers perform them.

OUTSIDE THE VEHICLE

The maintenance items listed here should be performed from time to time, unless otherwise specified.

Item		Reference page
Tires	Check the pressure with a gauge at least once a month and always prior to a long distance trip. Adjust to the specified pressure if necessary. Check carefully for damage, cuts or excessive wear.	—
Wheel lug nuts	When checking the tires, make sure no nuts are missing, and check for any loose nuts. Tighten if necessary.	WT-7, "Rotation"
Windshield	Clean the windshield on a regular basis. Check the windshield at least every six months for cracks or other damage. Repair as necessary.	
Tire rotation	Tires should be rotated every 12,000 km (7,500 miles).	WT-7, "Rotation"
Wheel alignment and balance	If the vehicle pulls to either side while driving on a straight and level road, or if you detect uneven or abnormal tire wear, there may be a need for wheel alignment. If the steering wheel or seat vibrates at normal highway speeds, wheel balancing may be needed.	WT-6, "Balancing Wheels" , FSU-6, "Front Wheel Alignment"
Windshield wiper blades	Check for cracks or wear if they do not wipe properly.	—
Doors and engine hood	Check that all doors and the engine hood operate smoothly as well as the back hatch. Also make sure that all latches lock securely. Lubricate if necessary. Make sure that the secondary latch keeps the hood from opening when the primary latch is released. When driving in areas using road salt or other corrosive materials, check lubrication frequently.	MA-33, "Lubricating Locks, Hinges and Hood Latches"
Lamps	Make sure that the head lamps, stop lamps, tail lamps, turn signal lamps, and other lamps are all operating properly and installed securely. Also check head lamp aim. Clean the head lamps on a regular basis.	LT-25, "Aiming Adjustment" for US, LT-40, "Aiming Adjustment" for Canada

INSIDE THE VEHICLE

The maintenance items listed here should be checked on a regular basis, such as when performing periodic maintenance, cleaning the vehicle, etc.

Item		Reference page
Warning lamps and buzzers/chimes	Make sure that all warning lamps and buzzers/chimes are operating properly.	DI-27, "Electrical Components Inspection"
Windshield wiper and washer	Check that the wipers and washer operate properly and that the wipers do not streak.	—
Windshield defroster	Check that the air comes out of the defroster outlets properly and in sufficient quantity when operating the heater or air conditioner.	—
Steering wheel	Check that it has the specified play. Be sure to check for changes in the steering condition, such as excessive play, hard steering or strange noises.	PS-8, "CHECKING STEERING WHEEL PLAY"
Seats	Check seat position controls such as seat adjusters, seat back recliner, etc. to make sure they operate smoothly and that all latches lock securely in every position. Check that the head restraints move up and down smoothly and that the locks (if equipped) hold securely in all latched positions. Check that the latches lock securely for folding-down rear seat backs.	—
Seat belts	Check that all parts of the seat belt system (e.g. buckles, anchors, adjusters and retractors) operate properly and smoothly and are installed securely. Check the belt webbing for cuts, fraying, wear or damage.	SB-8, "Seat Belt Inspection" , MA-34, "Checking Seat Belts, Buckles, Retractors, Anchors and Adjusters"
Accelerator pedal	Check the pedal for smooth operation. Keep the floor mats away from the pedal.	—

GENERAL MAINTENANCE

Item		Reference page
Brakes	Check that the brake does not pull the vehicle to one side when applied.	—
Brake pedal and booster	Check the pedal for smooth operation and make sure it has the proper distance under it when depressed fully. Check the brake booster function. Keep the floor mats away from the pedal.	BR-6, "Inspection and Adjustment" , BR-16, "On-Vehicle Service"
Parking brake	Check that the parking brake control has the proper travel and make sure that the vehicle is held securely on a fairly steep hill when only the parking brake is applied.	PB-3, "On-Vehicle Service"
Automatic transmission "Park" mechanism	On a fairly steep hill check that the vehicle is held securely with the selector lever in the P position without applying the brakes.	—

UNDER THE HOOD AND VEHICLE

The maintenance items listed here should be checked periodically (e.g. each time you check the engine oil or refuel).

Item		Reference page
Windshield washer fluid	Check that there is adequate fluid in the tank.	—
Engine coolant level	Check the coolant level when the engine is cold.	MA-13
Radiator and hoses	Check the front of the radiator and clean off any dirt, insects, leaves, etc., that may have accumulated. Make sure the hoses have no cracks, deformation, deterioration or loose connections.	—
Brake fluid level	Make sure that the brake fluid level is between the "MAX" and "MIN" lines on the reservoirs	MA-30
Battery	Check the fluid level in each cell. It should be between the "MAX" and "MIN" lines. Vehicles operated in high temperatures or under severe conditions require frequent checks of the battery fluid level.	—
Engine drive belt	Make sure that no belt is frayed, worn, cracked or oily.	MA-13
Engine oil level	Check the level on the dipstick after parking the vehicle on a level spot and turning off the engine.	MA-17
Power steering fluid level and lines	Check the level on the reservoir with the engine off. Check the lines for improper attachment, leaks, cracks, etc.	MA-32
Automatic transmission fluid level	Check the level on the dipstick after putting the selector lever in "P" with the engine idling.	MA-22
Exhaust system	Make sure there are no loose supports, cracks or holes. If the sound of the exhaust seems unusual or there is a smell of exhaust fumes, immediately locate the trouble and correct it.	MA-22
Underbody	The underbody is frequently exposed to corrosive substances such as those used on icy roads or to control dust. It is very important to remove these substances, otherwise rust will form on the floor pan, frame, fuel lines and around the exhaust system. At the end of winter, the underbody should be thoroughly flushed with plain water, being careful to clean those areas where mud and dirt can easily accumulate.	—
Fluid leaks	Check under the vehicle for fuel, oil, water or other fluid leaks after the vehicle has been parked for a while. Water dripping from the air conditioner after use is normal. If you should notice any leaks or gasoline fumes are evident, check for the cause and correct it immediately.	—

PERIODIC MAINTENANCE

PERIODIC MAINTENANCE

PFP:00026

Introduction of Periodic Maintenance

ELS001HK

Two different maintenance schedules are provided, and should be used, depending upon the conditions in which the vehicle is mainly operated. **After 60,000 miles (96,000 km) or 48 months, continue the periodic maintenance at the same mileage or time intervals, whichever comes first.**

Schedule 1	<p>Follow Periodic Maintenance Schedule 1 if your driving habits frequently includes one or more of the following driving conditions:</p> <ul style="list-style-type: none"> ● Repeated short trips of less than 5 miles (8 km). ● Repeated short trips of less than 10 miles (16 km) with outside temperatures remaining below freezing. ● Operating in hot weather in stop-and-go “rush hour” traffic. ● Extensive idling and/or low speed driving for long distances, such as police, taxi or door-to-door delivery use. ● Driving in dusty conditions. ● Driving on rough, muddy, or salt spread roads. ● Towing a trailer or using a car-top carrier. 	Emission Control System Maintenance	MA-7
		Chassis and Body Maintenance	MA-7
Schedule 2	<p>Follow Periodic Maintenance Schedule 2 if none of the driving conditions shown in Schedule 1 apply to the driving habits.</p>	Emission Control System Maintenance	MA-9
		Chassis and Body Maintenance	MA-9

Maintenance for off-road driving (4WD only)

After driving the vehicle off-road through sand, mud, or water; more frequent maintenance may be required for the following items:

- ▲ Brake pads and rotors
- ▲ Brake lines and hoses
- ▲ Rear final drive oil, transmission fluid, and transfer fluid
- ▲ Steering linkage
- ▲ Drive shafts
- ▲ Engine air cleaner filter
- ▲ In-cabin microfilters

Schedule 1

ELS001HL

EMISSION CONTROL SYSTEM MAINTENANCE

Abbreviations: R = Replace. I = Inspect. Correct or replace if necessary. []: At the mileage intervals only

MAINTENANCE OPERATION		MAINTENANCE INTERVAL								Reference Section - Page or - Content Title
Perform at number of miles, kilometers or months, whichever comes first.	Miles x 1,000 (km x 1,000) Months	3.75 (6)	7.50 (12)	11.25 (18)	15 (24)	18.75 (30)	22.5 (36)	26.25 (42)	30 (48)	
Drive belts	NOTE (1)									MA-13
Air cleaner filter	NOTE (2)								[R]	MA-17
EVAP vapor lines									I*	MA-20
Fuel lines									I*	MA-16
Fuel filter	NOTE (3)									—
Engine coolant	NOTE (4)									MA-16
Engine oil		R	R	R	R	R	R	R	R	MA-17
Engine oil filter		R	R	R	R	R	R	R	R	MA-18
Spark plugs (PLATINUM-TIPPED type)		Replace every 105,000 miles (169,000 km).								MA-19
Intake and exhaust valve clearance*	NOTE (5)									EM-139

PERIODIC MAINTENANCE

MAINTENANCE OPERATION		MAINTENANCE INTERVAL								Reference Section - Page or - Content Title
Perform at number of miles, kilometers or months, whichever comes first.	Miles x 1,000 (km x 1,000) Months	33.75 (54) 27	37.5 (60) 30	41.25 (66) 33	45 (72) 36	48.75 (78) 39	52.5 (84) 42	56.25 (90) 45	60 (96) 48	
Drive belts	NOTE (1)								I*	MA-13
Air cleaner filter	NOTE (2)								[R]	MA-17
EVAP vapor lines									I*	MA-20
Fuel lines									I*	MA-16
Fuel filter	NOTE (3)									MA-16
Engine coolant	NOTE (4)								R*	MA-13
Engine oil		R	R	R	R	R	R	R	R	MA-17
Engine oil filter		R	R	R	R	R	R	R	R	MA-18
Spark plugs (PLATINUM-TIPPED type)		Replace every 105,000 miles (169,000 km).								MA-19
Intake and exhaust valve clearance*	NOTE (5)									EM-139

- (1) After 60,000 miles (96,000 km) or 48 months, inspect every 15,000 miles (24,000 km) or 12 months. Replace the drive belts if found damaged, or if the auto tensioner reading reaches the maximum limit.
- (2) If operating mainly in dusty conditions, more frequent maintenance may be required.
- (3) Maintenance-free item. For service procedures, go to the FL section.
- (4) After 60,000 miles (96,000 km) or 48 months, replace every 30,000 miles (48,000 km) or 24 months.
- (5) If valve noise increases, inspect valve clearance.

* Maintenance items and intervals with "*" are recommended by NISSAN for reliable vehicle operation. The owner need not perform such maintenance in order to maintain the emission warranty or manufacturer recall liability. Other maintenance items and intervals are required.

CHASSIS AND BODY MAINTENANCE

Abbreviations: R = Replace. I = Inspect. Correct or replace if necessary. L = Lubricate. []: At the mileage intervals only.

MAINTENANCE OPERATION		MAINTENANCE INTERVAL								Reference Section - Page or - Content Title
Perform at number of miles, kilometers or months, whichever comes first.	Miles x 1,000 (km x 1,000) Months	3.75 (6) 3	7.5 (12) 6	11.25 (18) 9	15 (24) 12	18.75 (30) 15	22.5 (36) 18	26.25 (42) 21	30 (48) 24	
Brake lines and cables					I				I	MA-30
Brake pads and rotors			I		I		I		I	MA-31
Automatic transmission fluid	NOTE (1)				I				I	MA-22
Transfer fluid and front final drive oil	NOTE (1)				I				I	MA-25 , MA-26
Rear final drive oil	NOTE (1)				I				I	MA-27
Steering gear, linkage, axle, and suspension parts			I		I		I		I	MA-31 , MA-32
Tire rotation	NOTE (2)									MA-30
Drive shaft boots and propeller shaft (4WD)			I		I		I		I	MA-26
Exhaust system			I		I		I		I	MA-22
In-cabin microfilter					R				R	MA-21

PERIODIC MAINTENANCE

MAINTENANCE OPERATION		MAINTENANCE INTERVAL								Reference Section - Page or - Content Title
		Miles x 1,000 (54) 27	37.5 (60) 30	41.25 (66) 33	45 (72) 36	48.75 (78) 39	52.5 (84) 42	56.25 (90) 45	60 (96) 48	
Perform at number of miles, kilometers or months, whichever comes first.	Miles x 1,000 (km x 1,000) Months									
Brake lines and cables					I				I	MA-30
Brake pads and rotors			I		I		I		I	MA-31
Automatic transmission fluid	NOTE (1)				I				I	MA-22
Transfer fluid and front final drive oil	NOTE (1)				I				I	MA-25, MA-26
Rear final drive oil	NOTE (1)				I				I	MA-27
Steering gear, linkage, axle, and suspension parts			I		I		I		I	MA-31, MA-32
Tire Rotation	NOTE (2)									MA-30
Drive shaft boots and propeller shaft (4WD)			I		I		I		I	MA-26
Exhaust system			I		I		I		I	MA-22
In-cabin microfilter						R			R	MA-21

(1) If towing a trailer, or using a car-top carrier, or driving on rough or muddy roads, change (not just inspect) oil at every 30,000 miles (48,000 km) or 24 months.

(2) Refer to "Tire rotation" under the "General maintenance" heading earlier in this section.

Schedule 2 EMISSION CONTROL SYSTEM MAINTENANCE

ELS001HM

Abbreviations: R = Replace. I = Inspect. Correct or replace if necessary. []: At the mileage intervals only

MAINTENANCE OPERATION		MAINTENANCE INTERVAL								Reference Section - Page or - Content Title
		7.5 (12) 6	15 (24) 12	22.5 (36) 18	30 (48) 24	37.5 (60) 30	45 (72) 36	52.5 (84) 42	60 (96) 48	
Perform at number of miles, kilometers or months, whichever comes first.	Miles x 1,000 (km x 1,000) Months									
Drive belts	NOTE (1)								I*	MA-13
Air cleaner filter					[R]				[R]	MA-17
EVAP vapor lines					I*				I*	MA-20
Fuel lines					I*				I*	MA-16
Fuel filter	NOTE (2)									MA-16
Engine coolant	NOTE (3)								R*	MA-13
Engine oil		R	R	R	R	R	R	R	R	MA-17
Engine oil filter		R	R	R	R	R	R	R	R	MA-18
Spark plugs (PLATINUM-TIPPED type)		Replace every 105,000 miles (169,000 km).								MA-19
Intake and exhaust valve clearance*	NOTE (4)									EM-139

(1) After 60,000 miles (96,000 km) or 48 months, inspect every 15,000 miles (24,000 km) or 12 months. Replace the drive belts if found damaged, or if the auto tensioner reading reaches the maximum limit.

(2) Maintenance-free item. For service procedures, go to FL section.

(3) After 60,000 miles (96,000 km) or 48 months, replace every 30,000 miles (48,000 km) or 24 months.

(4) If valve noise increases, inspect valve clearance.

* Maintenance items and intervals with "*" are recommended by NISSAN for reliable vehicle operation. The owner need not perform such maintenance in order to maintain the emission warranty or manufacturer recall liability. Other maintenance items and intervals are required.

PERIODIC MAINTENANCE

CHASSIS AND BODY MAINTENANCE

Abbreviations: R = Replace. I = Inspect. Correct or replace if necessary. L = Lubricate. []: At the mileage interval only.

MAINTENANCE OPERATION		MAINTENANCE INTERVAL								Reference Section - Page or - Content Title
		Miles x 1,000 (km x 1,000) Months	7.5 (12) 6	15 (24) 12	22.5 (36) 18	30 (48) 24	37.5 (60) 30	45 (72) 36	52.5 (84) 42	
Perform at number of miles, kilometers or months, whichever comes first.										
Brake lines and cables			I		I		I		I	MA-30
Brake pads and rotors			I		I		I		I	MA-31
Automatic transmission fluid			I		I		I		I	MA-22
Transfer fluid and front final drive oil			I		I		I		I	MA-25 , MA-26
Rear final drive oil			I		I		I		I	MA-27
Steering gear, linkage, axle, and suspension parts.					I				I	MA-31 , MA-32
Tire rotation	NOTE (1)									MA-30
Drive shaft boots and propeller shaft (4WD)			I		I		I		I	MA-26
Exhaust system					I				I	MA-22
In-cabin microfilter			R		R		R		R	MA-21

(1) Refer to "Tire rotation" under the "General maintenance" heading earlier in this section.

RECOMMENDED FLUIDS AND LUBRICANTS

RECOMMENDED FLUIDS AND LUBRICANTS

PF0:0000

Fluids and Lubricants

ELS001HN

Description		Capacity (Approximate)			Recommended Fluids/Lubricants
		Metric	US measure	Imp measure	
Fuel		80 ℓ	21 1/8 gal	17 5/8 gal	Unleaded gasoline with an octane rating of at least 87 AKI (RON 91) *9
Engine oil Drain and refill	With oil filter change	5.1 ℓ	5 3/8 qt	4 1/2 qt	<ul style="list-style-type: none"> ● API Certification Mark*1 ● API grade SL, Energy Conserving*1 ● ILSAC grade GF-III*1
	Without oil filter change	4.8 ℓ	5 1/8 qt	4 1/4 qt	
Dry engine (engine overhaul)		6.3 ℓ	6 5/8 qt	5 1/2 qt	
Cooling system	With reservoir at MAX level	10.2 ℓ	2 3/4 gal	2 1/4 gal	Genuine NISSAN Long Life Anti-freeze coolant or equivalent
Automatic transmission fluid (ATF)		10.3 ℓ	10 7/8 qt	9 1/8 qt	Genuine NISSAN Matic J ATF *2
Manual transmission fluid (MTF) (6 M/T)	2WD	3.98 ℓ	8 3/8 pt	7 pt	Genuine NISSAN Manual Transmission Fluid (MTF) HQ Multi 75W-85 or API GL-4, Viscosity SAE 75W-85 or 75W-90
	4WD	4.18 ℓ	8 7/8 pt	7 3/8 pt	
Rear final drive oil	C200	1.6 ℓ	3 3/8 pt	2 7/8 pt	API GL-5 Synthetic 75W-90 Gear Oil (Part No. 999MP-DF200P) or equivalent *6
	M226	2.01 ℓ	4 1/4 pt	3 1/2 pt	API GL-5 Synthetic 75W-140 Gear Oil (Part No. 999MP-DF100P) or equivalent *6
Transfer fluid	TX15B	2.0 ℓ	2 1/8 qt	1 3/4 qt	Genuine NISSAN Matic D ATF (Continental U.S and Alaska) or Canada NISSAN Automatic Transmission Fluid *8
Front final drive oil		0.85 ℓ	1 3/4 pt	1 1/2 pt	API GL-5 Viscosity SAE 80W-90 *7
Power steering fluid (PSF)		1.0 ℓ	2 1/8 pt	1 3/4 pt	Genuine NISSAN PSF or equivalent *3
Brake fluid		—	—	—	Genuine NISSAN Super Heavy Duty Brake Fluid or equivalent, DOT 3 (US FMVSS No. 116) *4
Brake grease		—	—	—	PBC (poly butyl cuprysil)
Brake pad plate grease		—	—	—	Molykote AS880N grease
Multi-purpose grease		—	—	—	NLGI No. 2 (lithium soap base)
Windshield washer fluid		4.5 ℓ	1 1/4 gal	1 gal	Genuine NISSAN Windshield Washer Concentrate Cleaner & Anti-freeze or equivalent
A/C system refrigerant		0.70 ± 0.05 kg	1.54 ± 0.11 lb	1.54 ± 0.11 lb	HFC-134a (R134a) *5
A/C system oil		180 m ℓ	6.1 fl oz	6.3 fl oz	NISSAN A/C System Oil Type R or equivalent *5

*1: For further details, refer to [MA-12, "SAE Viscosity Number"](#).

*2: Using automatic transmission fluid other than Genuine NISSAN Matic J ATF will cause deterioration in driveability and automatic transmission durability, and may damage the automatic transmission, which is not covered by the NISSAN new vehicle limited warranty.

*3: For Canada, NISSAN Automatic Transmission Fluid (ATF), DEXRON™ III or MERCON™ or equivalent ATF may also be used.

*4: Available in mainland U.S.A. through your NISSAN dealer.

*5: For further details, see "Air conditioner Specification Label".

*6: See your NISSAN dealer for service for synthetic oil.

*7: For hot climates, viscosity SAE 90 is suitable for ambient temperatures above 0° C (32° F).

*8: DEXRON™ III, MERCON™ or equivalent may also be used. Outside the continental United States and Alaska contact a NISSAN dealership for more information regarding suitable fluids, including recommended brand(s) of DEXRON™ III or MERCON™ Automatic Transmission Fluid.

*9: For further details, refer to [GI-5, "Precautions for Fuel \(Unleaded Gasoline Recommended\)"](#).

RECOMMENDED FLUIDS AND LUBRICANTS

ELS001HO

SAE Viscosity Number GASOLINE ENGINE OIL

- SAE 5W-30 viscosity oil is preferred for all temperatures. SAE 10W-30 and 10W-40 viscosity oil may be used if the ambient temperature is above -18°C (0°F).
- Use of 5W-30 viscosity oil will increase fuel economy.

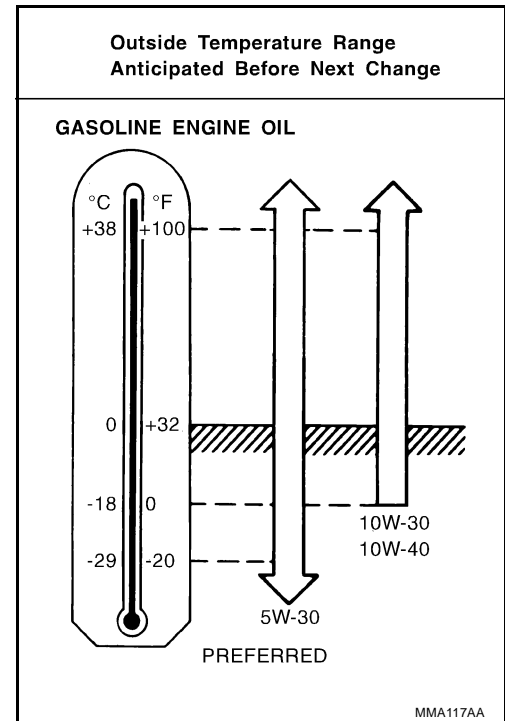

ANTI-FREEZE COOLANT MIXTURE RATIO

The engine cooling system is filled at the factory with a high-quality, long life, year-round, anti-freeze coolant solution. The anti-freeze solution contains rust and corrosion inhibitors. Therefore, additional cooling system additives are not necessary.

For outside temperatures down to:		Anti-freeze coolant mixture ratio	
° C	° F	Genuine NISSAN Long Life Antifreeze coolant	Demineralized water or distilled water
- 35°	- 30°	50 %	50 %

CAUTION:

- When adding or replacing coolant, be sure to use only Genuine NISSAN Long Life Anti-freeze coolant or equivalent with the proper mixture ratio of 50% anti-freeze and 50% demineralized water or distilled water.
- Other types of coolant solutions may damage your cooling system.

ENGINE MAINTENANCE

PFP:00000

Checking Drive Belts

ELS001MD

Drive Belt Routing

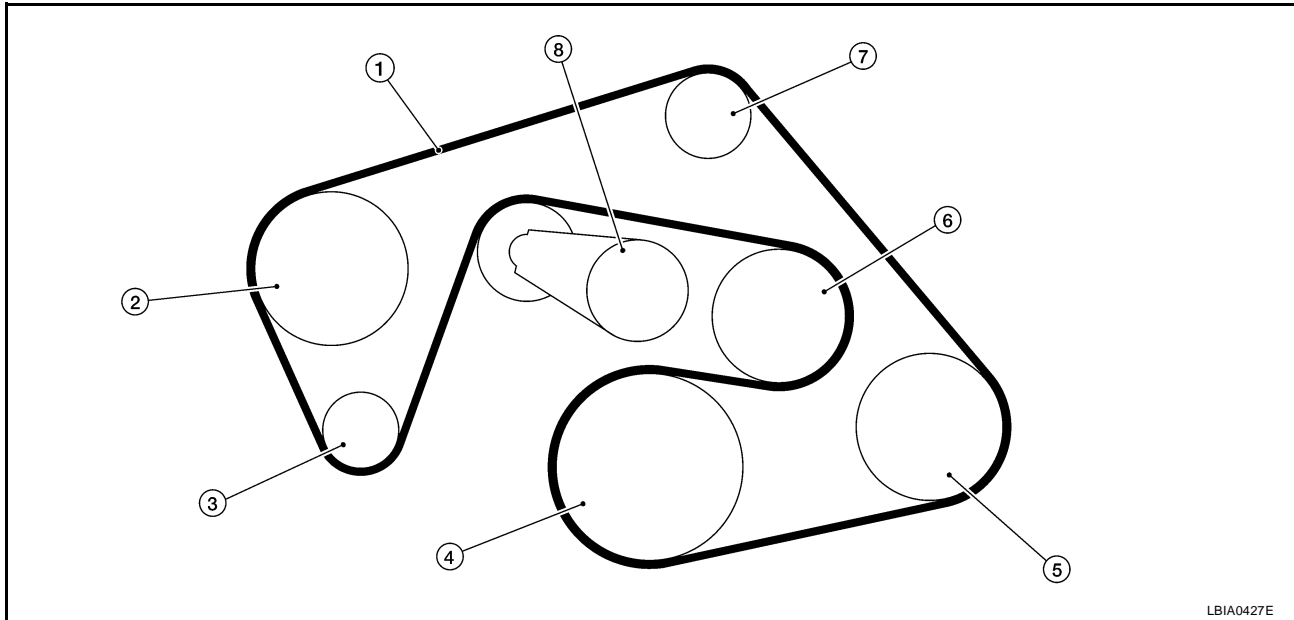

LBIA0427E

- | | | |
|----------------------|-------------------------------|-----------------------|
| 1. Drive belt | 2. Power steering pump pulley | 3. Generator pulley |
| 4. Crankshaft pulley | 5. A/C compressor | 6. Cooling fan pulley |
| 7. Idler pulley | 8. Drive belt auto-tensioner | |

WARNING:

Be sure to perform the inspection when the engine is stopped.

1. Remove the air duct and resonator assembly (inlet) when inspecting the drive belt.
2. Visually check the entire drive belt for wear, damage or cracks.

DRIVE BELT TENSION ADJUSTMENT

There is no manual drive belt tension adjustment. The drive belt tension is automatically adjusted by the drive belt auto-tensioner.

Changing Engine Coolant

ELS001ME

WARNING:

- To avoid being scalded, never change the coolant when the engine is hot.
- Wrap a thick cloth around the cap to carefully remove the cap. First, turn the cap a quarter of a turn to release any built-up pressure, then push down and turn the cap all the way to remove it.

DRAINING ENGINE COOLANT

1. Turn ignition switch ON and set temperature control lever all the way to HOT position or the highest temperature position. Wait 10 seconds and turn ignition switch OFF.
2. Remove the engine front undercover using power tool.
3. Open the radiator drain plug at the bottom of the radiator, and remove the reservoir cap. This is the only step required when partially draining the cooling system (radiator only).

CAUTION:

Do not to allow the coolant to contaminate the drive belts.

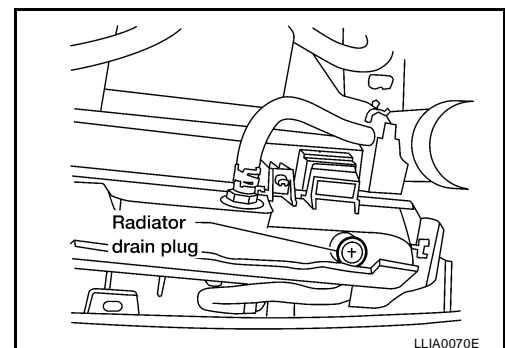

LLIA0070E

ENGINE MAINTENANCE

- When draining all of the coolant in the system for engine removal or repair, it is necessary to drain the cylinder block. Remove the cylinder block drain plugs, and block heater if equipped, to drain the cylinder block as shown.

NOTE:

For Canada, the “D” cylinder block drain plug as shown, is not a cylinder block drain plug but a block heater.

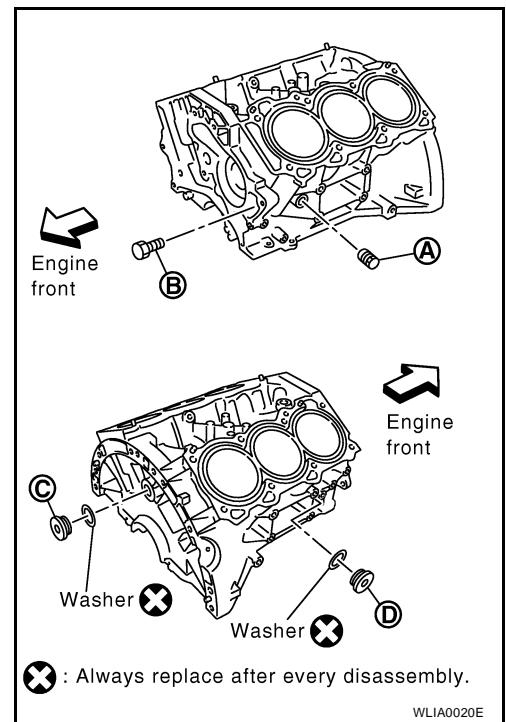

- Remove the reservoir tank to drain the engine coolant, then clean the reservoir tank before installing it.
- Check the drained coolant for contaminants such as rust, corrosion or discoloration. If the coolant is contaminated, flush the engine cooling system. Refer to [MA-16, "FLUSHING COOLING SYSTEM"](#).

REFILLING ENGINE COOLANT

- Close the radiator drain plug. Install the reservoir tank, cylinder block drain plugs, and block heater if equipped, if removed for a total system drain or for engine removal or repair.
 - The radiator must be completely empty of coolant and water.
 - Apply sealant to the threads of the cylinder block drain plug. Use Genuine High Performance Thread Sealant or equivalent. Refer to [GI-48, "Recommended Chemical Products and Sealants"](#).

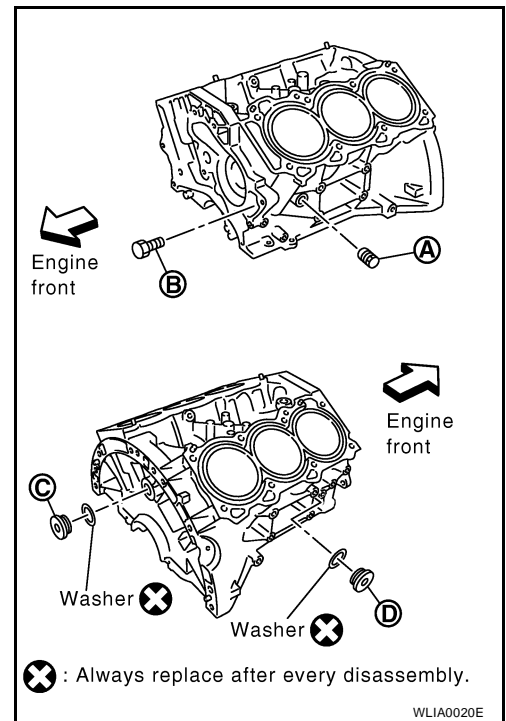

ENGINE MAINTENANCE

Block Plug and Block Heater Installation

Part	Washer	Tightening Torque
A	No	19.6 N·m (2.0 kg·m, 14 ft·lb)
B	Reuse	9.8 N·m (1.0 kg·m, 87 in·lb)
	New	6.0 N·m (0.61 kg·m, 53 in·lb)
C	Yes	62 N·m (6.3 kg·m, 46 ft·lb)
D	Plug	62 N·m (6.3 kg·m, 46 ft·lb)
	Block heater	73.5 N·m (7.5 kg·m, 54 ft·lb)

- Set the vehicle heater controls to the full HOT and heater ON position. Turn the vehicle ignition ON with the engine OFF as necessary to activate the heater mode.
- Remove the vented reservoir cap and replace it with a non-vented reservoir cap before filling the cooling system.

- Install the Tool by installing the radiator cap adapter onto the radiator neck opening. Then attach the gauge body assembly with the refill tube and the venturi assembly to the radiator cap adapter.

Tool number : KV991J0070 (J-45695)

- Insert the refill hose into the coolant mixture container that is placed at floor level. Make sure the ball valve is in the closed position.

- Use Genuine NISSAN Long Life Anti-freeze coolant or equivalent, mixed 50/50 with distilled water or demineralized water. Refer to [MA-12, "ANTI-FREEZE COOLANT MIXTURE RATIO"](#).

Cooling system capacity (with reservoir) : Refer to [MA-11, "Fluids and Lubricants"](#).

- Install an air hose to the venturi assembly, the air pressure must be within specification.

Compressed air supply pressure : 5.7 - 8.5 kPa (5.6 - 8.4 kg/cm², 80 - 120 psi)

CAUTION:

The compressed air supply must be equipped with an air dryer.

- The vacuum gauge will begin to rise and there will be an audible hissing noise. During this process open the ball valve on the refill hose slightly. Coolant will be visible rising in the refill hose. Once the refill hose is full of coolant, close the ball valve. This will purge any air trapped in the refill hose.

- Continue to draw the vacuum until the gauge reaches 28 inches of vacuum. The gauge may not reach 28 inches in high altitude locations, refer to the vacuum specifications based on the altitude above sea level.

Altitude above sea level	Vacuum gauge reading
0 - 100 m (328 ft)	: 28 inches of vacuum
300 m (984 ft)	: 27 inches of vacuum
500 m (1,641 ft)	: 26 inches of vacuum
1,000 m (3,281 ft)	: 24 - 25 inches of vacuum

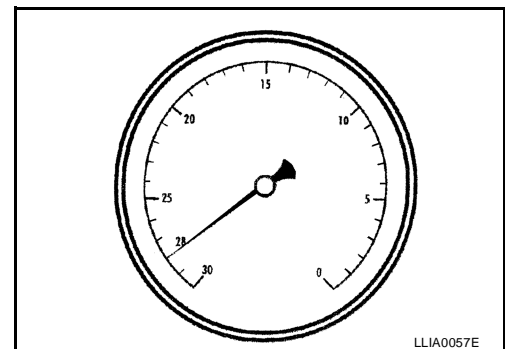
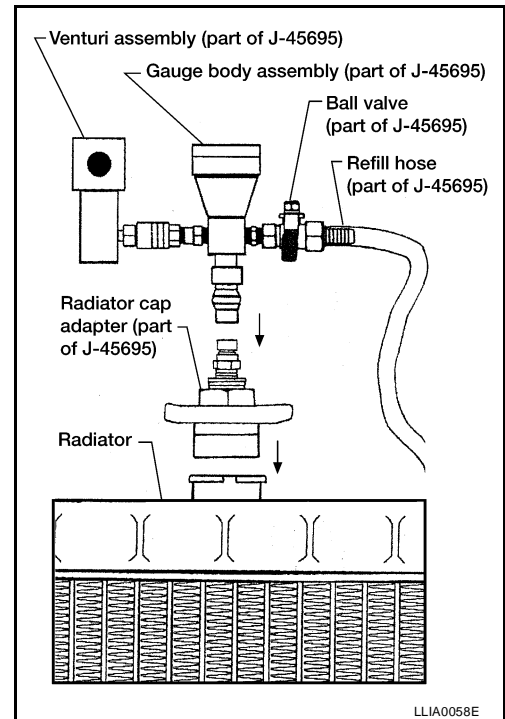

- When the vacuum gauge has reached the specified amount, disconnect the air hose and wait 20 seconds to see if the system loses any vacuum. If the vacuum level drops, perform any necessary repairs to the system and repeat steps 6 - 8 to bring the vacuum to the specified amount. Recheck for any leaks.

ENGINE MAINTENANCE

10. Place the coolant container (with the refill hose inserted) at the same level as the top of the radiator. Then open the ball valve on the refill hose so the coolant will be drawn up to fill the cooling system. The cooling system is full when the vacuum gauge reads zero.

CAUTION:

Do not allow the coolant container to get too low when filling, to avoid air from being drawn into the cooling system.

11. Remove the Tool from the radiator neck opening and install the radiator cap.
12. Remove the reservoir cap.
13. Fill the cooling system reservoir tank to the specified level. Run the engine to warm up the cooling system and top up the system as necessary before installing the reservoir cap.

FLUSHING COOLING SYSTEM

1. Drain the water from the engine cooling system. Refer to [MA-13, "DRAINING ENGINE COOLANT"](#) .
2. Fill the radiator and the reservoir tank (to the "MAX" line), with water. Reinstall the radiator cap and leave the vented reservoir cap off.
3. Run the engine until it reaches normal operating temperature.
4. Press the engine accelerator two or three times under no-load.
5. Stop the engine and wait until it cools down.
6. Drain the water from the engine cooling system. Refer to [MA-13, "DRAINING ENGINE COOLANT"](#) .
7. Repeat steps 2 through 6 until clear water begins to drain from the radiator.

Checking Fuel Lines

Inspect the fuel lines and fuel tank for improper mounting, leaks, cracks, damage, loose connections, chafing, or deterioration. As necessary, repair or replace any faulty parts.

ELS001MF

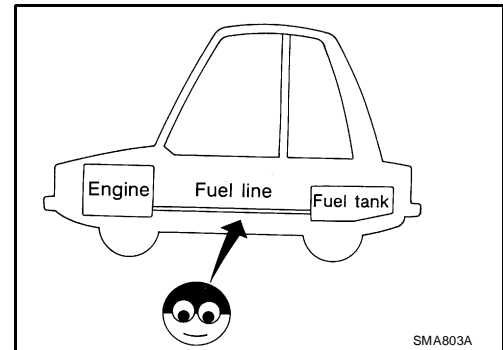

SMA803A

Changing Fuel Filter

The fuel filter is part of the fuel level sensor unit, fuel filter and fuel pump assembly. Refer to [FL-6, "FUEL LEVEL SENSOR UNIT, FUEL FILTER AND FUEL PUMP ASSEMBLY"](#) .

WARNING:

Before replacing the fuel filter, release the fuel pressure from the fuel system. Refer to [EC-80, "FUEL PRESSURE RELEASE"](#) .

ELS001MG

ENGINE MAINTENANCE

Changing Engine Air Cleaner Filter VISCIOUS PAPER TYPE

ELS001MH

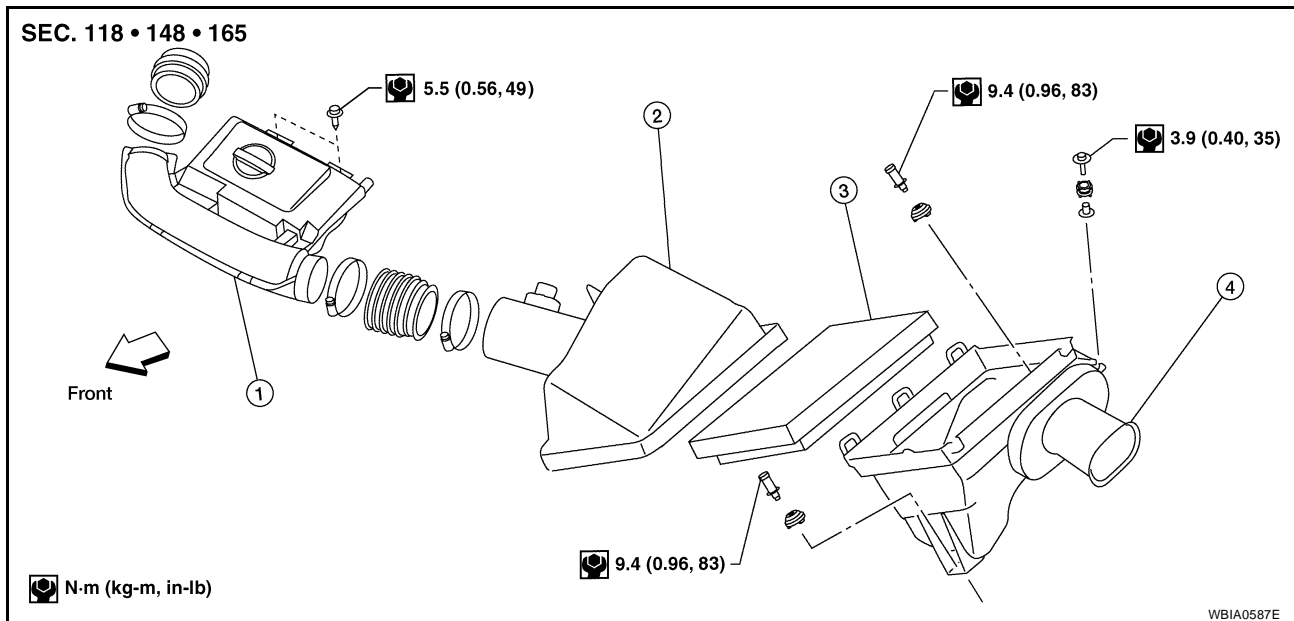

1. Air duct and resonator assembly
2. Air cleaner case (upper)
3. Air cleaner filter
4. Air cleaner case (lower)

NOTE:

- The viscous paper type filter does not need cleaning between replacement intervals.
 - Replace the air filter as necessary for required maintenance.
1. Unhook the clips and raise the air cleaner case (upper).
 2. Remove the air cleaner filter from the air cleaner case (lower).
 3. Install the new air cleaner filter in the air cleaner case (lower).
 4. Lower the air cleaner case (upper) into position and hook the clips.

Changing Engine Oil

ELS001MI

WARNING:

- Be careful not to burn yourself, as the engine oil is hot.
- Prolonged and repeated contact with used engine oil may cause skin cancer; try to avoid direct skin contact with used oil. If skin contact is made, wash thoroughly with soap or hand cleaner as soon as possible.

1. Warm up the engine, and check for any oil leaks.
2. Stop the engine and wait for at least 10 minutes.
3. Loosen the oil filler cap, then remove the drain plug.
4. Drain the engine oil.
5. Install the drain plug with a new washer.

Oil pan drain plug : Refer to [EM-108, "CYLINDER BLOCK"](#) .

CAUTION:

Clean the drain plug and install with a new washer.

6. Refill with new engine oil.

Oil viscosity and capacity : Refer to [MA-11, "Fluids and Lubricants"](#) .

CAUTION:

- The refill capacity depends on the oil temperature and drain time. Use the specifications for reference only.
 - Always use the dipstick to determine when the proper amount of oil is in the engine.
7. Warm up the engine and check the area around the drain plug and oil filter for any oil leaks.

ENGINE MAINTENANCE

8. Stop the engine and wait for 10 minutes.
9. Check the oil level using the dipstick as shown.

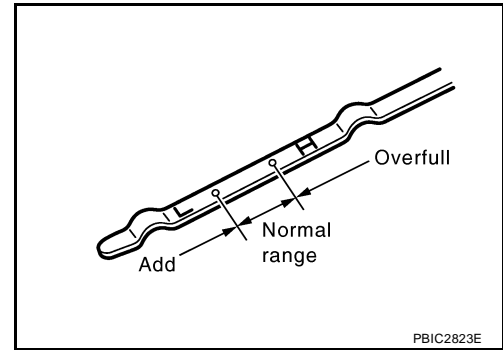

Changing Oil Filter

ELS001MJ

1. Remove the undercover using power tool.
2. Remove the oil filter using Tool.

Tool number : KV10115801 (J-38956)

WARNING:

Be careful not to burn yourself, as the engine and engine oil are hot.

CAUTION:

- Oil filter is provided with relief valve. Use Genuine NISSAN Oil Filter or equivalent.
 - When removing, prepare a shop cloth to absorb any engine oil leakage or spillage.
 - Do not allow engine oil to adhere to drive belts.
 - Completely wipe off any engine oil that adheres to engine and vehicle.
3. Remove foreign materials adhering to the oil filter installation surface.
 4. Coat the oil filter rubber seal with engine oil as shown.

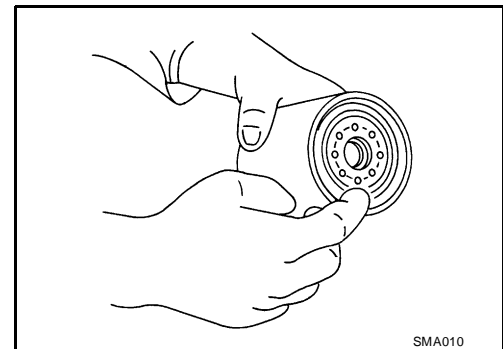

5. Screw on the oil filter until a slight resistance is felt, then tighten the oil filter an additional 2/3 turn as shown using Tool. Or tighten to specification.

Oil filter : Refer to [EM-108, "CYLINDER BLOCK"](#)

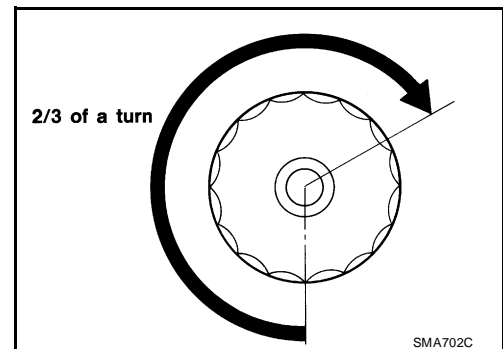

6. Install the undercover.
7. Check the oil level using the dipstick and adjust the engine oil level as necessary.
8. Start the engine and check for engine oil leaks, correct as necessary.
9. Stop the engine and wait for 10 minutes.
10. Check the oil level using the dipstick and adjust the engine oil level as necessary.

ENGINE MAINTENANCE

Changing Spark Plugs (Platinum - Tipped Type)

ELS001MK

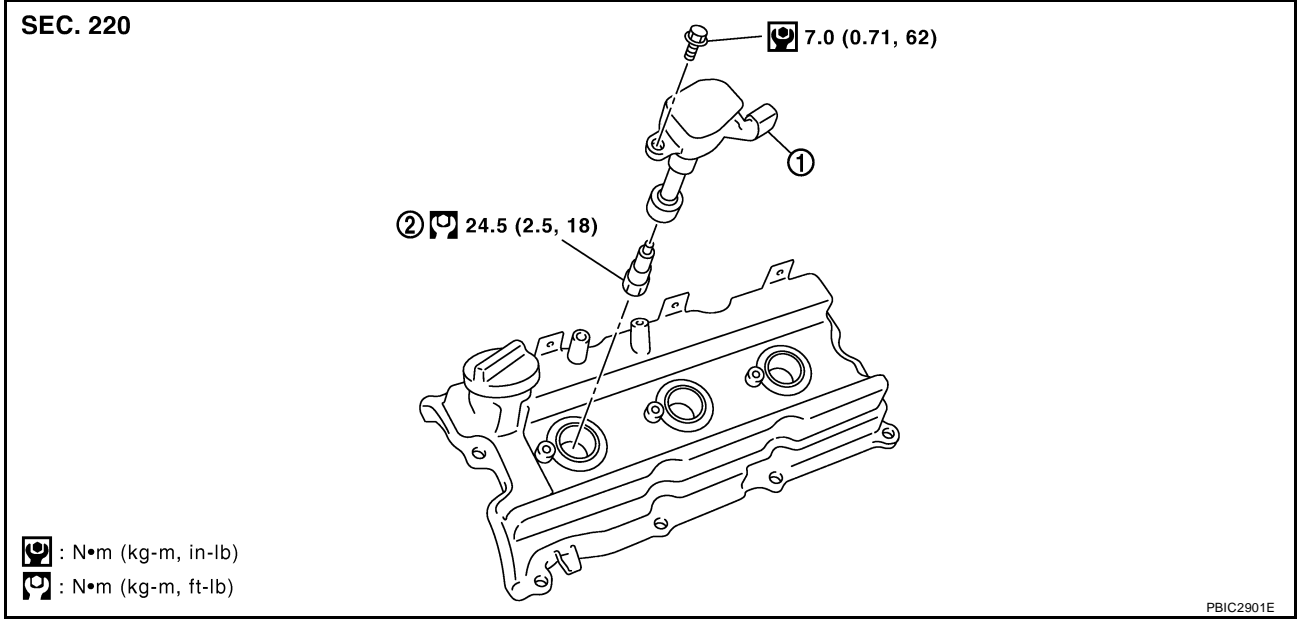

REMOVAL

1. Remove the ignition coil. Refer to [EM-32, "IGNITION COIL"](#).
2. Remove the spark plug using a suitable tool.

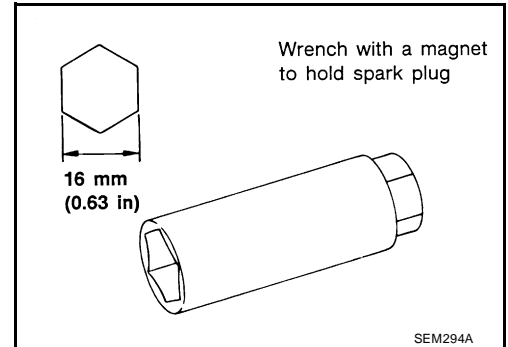

INSPECTION AFTER REMOVAL

- If plug tip is covered with carbon, spark plug cleaner may be used.

Cleaner air pressure : Less than 588 kPa (5.9 bar, 6 kg/cm², 85 psi)

Cleaning time : Less than 20 seconds

- Checking and adjusting plug gap is not required between change intervals.

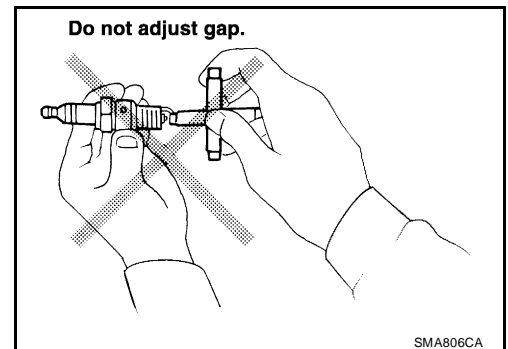

ENGINE MAINTENANCE

CAUTION:

- Do not use a wire brush to clean the spark plug.
- Do not drop or shock the spark plug.

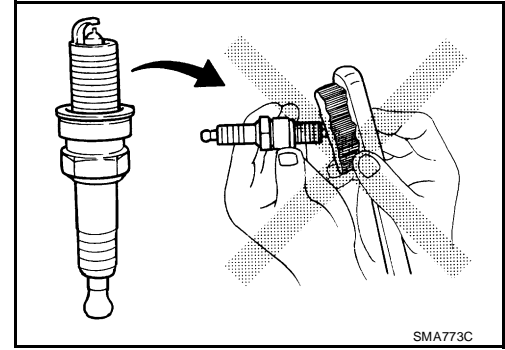

INSTALLATION

Installation is in the reverse order of removal.

- Use standard type spark plug for normal conditions.
- The hot type spark plug is suitable when fouling occurs with the standard type spark plug under conditions such as:
 - Frequent engine starts
 - Low ambient temperatures
- The cold type spark plug is suitable when spark knock occurs with the standard type spark plug under conditions such as:
 - Extended highway driving
 - Frequent high engine revolution

Make	NGK
Standard type	PLFR5A-11
Hot type	PLFR4A-11
Cold type	PLFR6A-11
Gap (nominal)	1.1 mm (0.043 in)

CAUTION:

Do not drop or shock the spark plug.

Checking EVAP Vapor Lines

ELS001ML

1. Visually inspect EVAP vapor lines for improper attachment, cracks, damage, loose connections, chafing or deterioration.
2. Inspect vacuum relief valve of fuel tank filler cap for clogging, sticking, etc.
Refer to [EC-36, "How to Detect Fuel Vapor Leakage"](#).

CHASSIS AND BODY MAINTENANCE

CHASSIS AND BODY MAINTENANCE

PFP:00100

ELS001MM

Changing the In-cabin Microfilter

1. Open the lower glove box and press in on the sides so that it will open completely allowing it to hang by the cord.

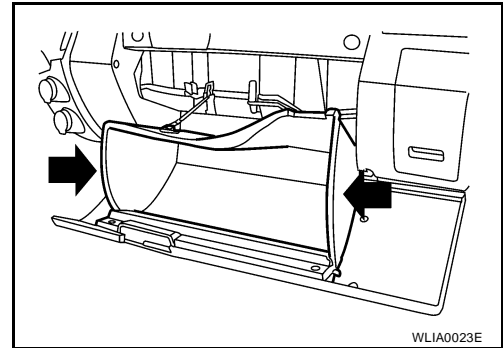

2. Remove the screw and remove the in-cabin microfilter cover.
3. Remove the in-cabin microfilters from the front heater and cooling unit housing.

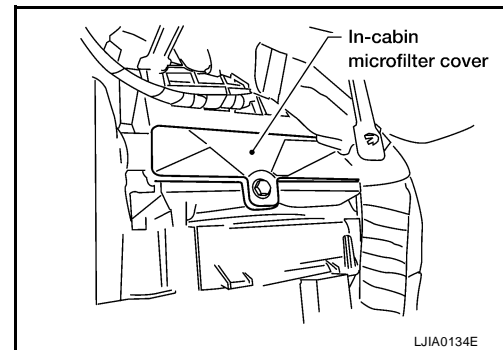

4. Insert the first new in-cabin microfilter into the front heater and cooling unit housing and slide it over to the right. Insert the second new in-cabin microfilter into the front heater and cooling unit housing.

NOTE:

The in-cabin microfilters are marked with air flow arrows. The end of the microfilter with the arrow should face the rear of the vehicle. The arrows should point downward.

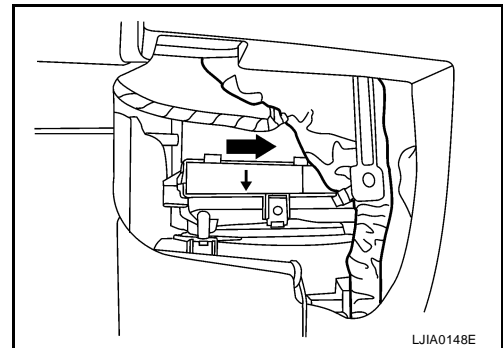

5. Install the in-cabin microfilter cover.

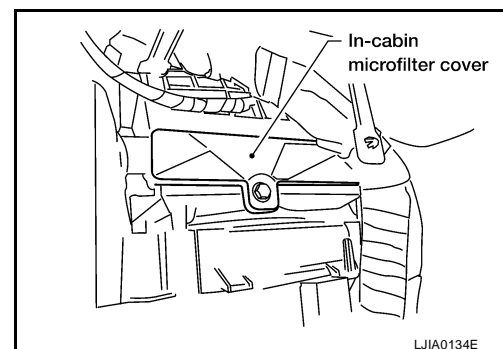

6. Close the lower glove box completely.

A
B
C
D
E
F
G
H
I
J
K
MA
M

CHASSIS AND BODY MAINTENANCE

Checking the Exhaust System

ELS001MN

Check exhaust pipes, muffler and mounting for improper attachment, leaks, cracks, damage, loose connections, chafing or deterioration.

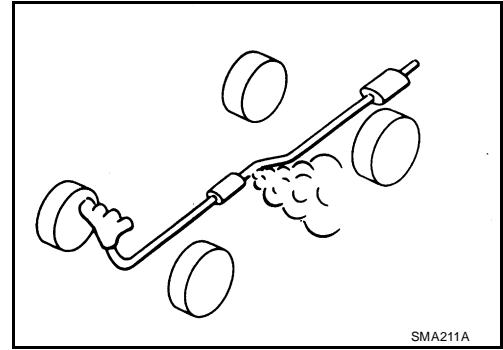

Checking the Automatic Transmission Fluid (ATF)

ELS001MO

1. Before driving, the ATF level can be checked at ATF temperatures of 30° to 50° C (86° to 122° F) using the "COLD" range on the ATF level gauge as follows:

- Park the vehicle on a level surface and set the parking brake.
- Start the engine and move the selector lever through each gear position. Shift the selector lever into the "P" position.
- Check the ATF level with the engine idling.
- Remove the ATF level gauge and wipe it clean with a lint-free paper.

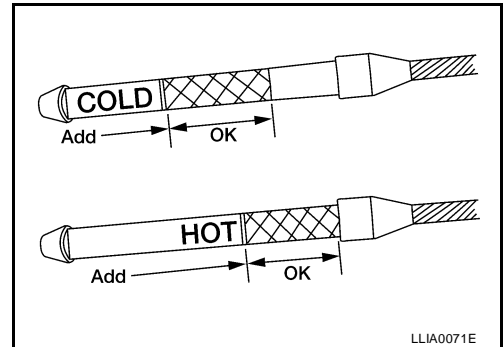

CAUTION:

When wiping the ATF from the ATF level gauge, always use a lint-free paper, not a cloth.

e. Re-insert the ATF level gauge into the charging pipe until the cap contacts the top of the charging pipe as shown.

CAUTION:

To check ATF level, insert the ATF level gauge until the cap contacts the top of the charging pipe, with the gauge reversed from the normal inserted position.

f. Remove the ATF level gauge and note the ATF level. If the ATF level is at low side of range, add ATF to the transmission through the charging pipe.

CAUTION:

Do not overfill the transmission with ATF.

g. Install the ATF level gauge and the ATF level gauge bolt.

ATF level gauge bolt : Refer to [AT-254, "Components"](#) .

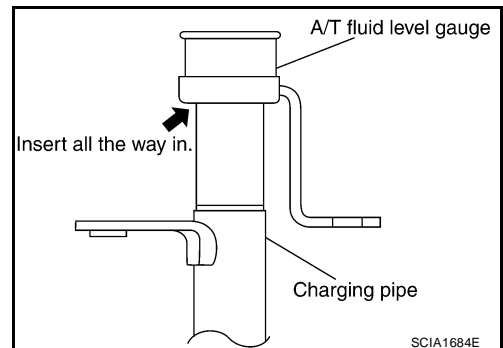

- Warm up the engine and transmission.
- Check for any ATF leaks.
- Drive the vehicle to increase the ATF temperature to 80° C (176° F).

CHASSIS AND BODY MAINTENANCE

- Allow the ATF temperature to fall to approximately 65°C (149°F). Use the CONSULT-II to monitor the ATF temperature as follows:

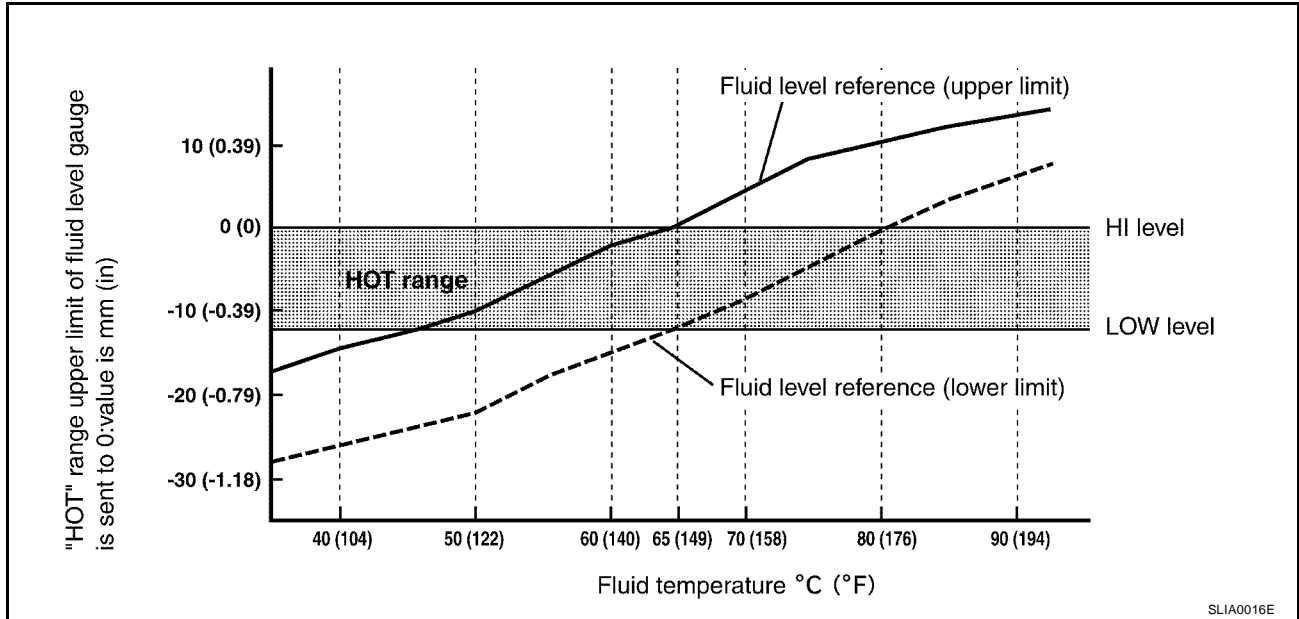

NOTE:

The ATF level will be significantly affected by the ATF temperature as shown. Therefore monitor the ATF temperature data using the CONSULT-II.

- Connect CONSULT-II to data link connector.
 - Select "MAIN SIGNALS" in "DATA MONITOR" mode for "A/T" with CONSULT-II.
 - Read out the value of "ATF TEMP 1".
- Re-check the ATF level at ATF temperatures of approximately 65°C (149°F) using the "HOT" range on the ATF level gauge as shown. The HOT range is between 50° - 80° C (122° - 176° F).

CAUTION:

- When wiping the ATF from the ATF level gauge, always use lint-free paper, not a cloth.

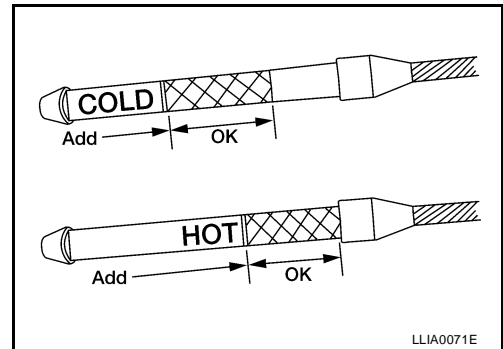

- To check the ATF level, insert the ATF level gauge until the cap contacts the top of the charging pipe, with the gauge reversed from the normal inserted position as shown.

- Check the ATF condition.

- If the ATF is very dark or has some burned smell, there may be an internal problem with the transmission. Refer to [AT-182, "TROUBLE DIAGNOSIS FOR SYMPTOMS"](#). Flush the transmission cooling system after repairing the transmission.
- If the ATF contains frictional material (clutches, bands, etc.), replace the radiator and flush the transmission cooler lines using cleaning solvent and compressed air after repairing the transmission.

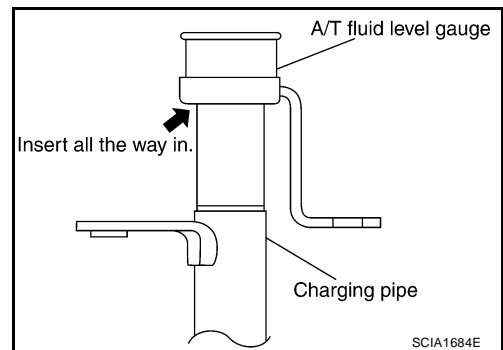

- Install the ATF level gauge in the charging pipe.
- Tighten the ATF level gauge bolt to specification.

ATF level gauge bolt : Refer to [AT-254, "Components"](#) .

CHASSIS AND BODY MAINTENANCE

Changing the Automatic Transmission Fluid (ATF)

ELS001MP

1. Drive the vehicle to warm up the ATF to approximately 80° C (176° F).
2. Stop the engine.
3. Remove the ATF level gauge.
4. Drain the ATF from the drain plug hole and then install the drain plug with a new gasket. Refill the transmission with new ATF. Always refill with the same volume as the drained ATF. Use the ATF level gauge to check the ATF level as shown. Add ATF as necessary.

Drain plug : Refer to [AT-254, "Components"](#) .

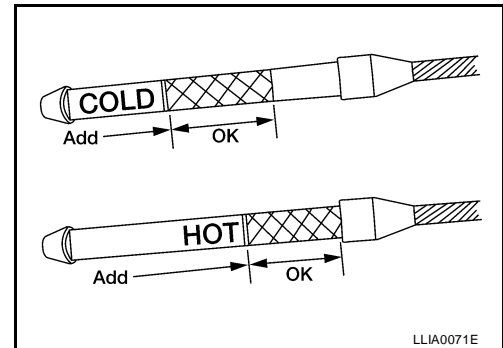

- To flush out the old ATF from the transmission oil coolers, pour new ATF into the charging pipe with the engine idling and at the same time drain the old ATF from the auxiliary transmission oil cooler hose return line.
- When the color of the ATF coming out of the auxiliary transmission oil cooler hose return line is about the same as the color of the new ATF, flushing out the old ATF is complete. The amount of new ATF used for flushing should be 30% to 50% of the specified capacity.

ATF type and capacity : Refer to [MA-11, "Fluids and Lubricants"](#) .

CAUTION:

- Use only Genuine NISSAN ATF and do not mix with other fluids.
 - Using automatic transmission fluid other than Genuine NISSAN ATF will cause deterioration in driveability and automatic transmission durability, and may damage the automatic transmission, which is not covered by the warranty.
 - When filling the transmission with ATF, do not spill the ATF on any heat generating parts such as the exhaust manifold.
 - Do not reuse the drain plug gasket.
5. Drive the vehicle to warm up the ATF to approximately 80° C (176° F).
 6. Install the ATF level gauge and tighten the ATF level gauge bolt to specification.

ATF level gauge bolt : Refer to [AT-254, "Components"](#) .

7. Check the fluid level and condition. If the ATF is still dirty, repeat steps 2 through 6.

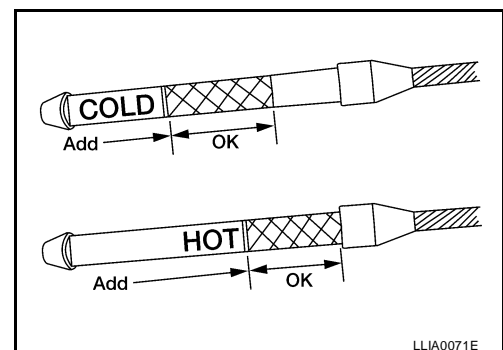

8. Install the ATF level gauge in the charging pipe and install the ATF level gauge bolt.
9. Tighten the ATF level gauge bolt to specification.

ATF level gauge bolt : Refer to [AT-254, "Components"](#) .

Checking the Manual Transmission Fluid (MTF) OIL LEAKAGE AND OIL LEVEL

ELS001MQ

1. Make sure that oil is not leaking from the transmission or around it.

CHASSIS AND BODY MAINTENANCE

2. Check oil level from the filler plug hole as shown.

CAUTION:

Do not start engine while checking oil level.

3. Set a gasket on the filler plug and install it to the transmission. Tighten the filler plug to the specified torque. Refer to [MT-22, "COMPONENTS"](#).

CAUTION:

Do not reuse gasket.

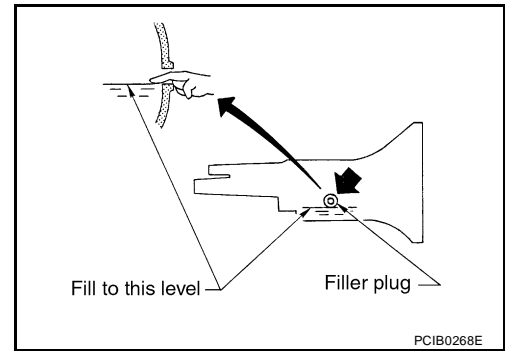

PCIB0268E

ELS001MR

Changing the Manual Transmission Fluid (MTF) DRAINING

1. Start the engine and let it run to warm up the transmission.
2. Stop the engine. Remove the transmission drain plug and drain the oil.
3. Set a gasket on the drain plug and install it to the transmission. Tighten the drain plug to the specified torque. Refer to [MT-22, "COMPONENTS"](#).

CAUTION:

Do no reuse gasket.

FILLING

1. Remove the filler plug. Fill with new oil until oil level reaches the specified limit near the filler plug hole.

Oil grade and Viscosity : Refer to [MA-11, "Fluids and Lubricants"](#).

Oil capacity : Refer to [MA-11, "Fluids and Lubricants"](#).

2. After refilling the oil, check oil level. Set a gasket to the filler plug, then install it to the transmission. Tighten the filler plug to the specified torque. Refer to [MT-22, "COMPONENTS"](#).

CAUTION:

Do not reuse gasket.

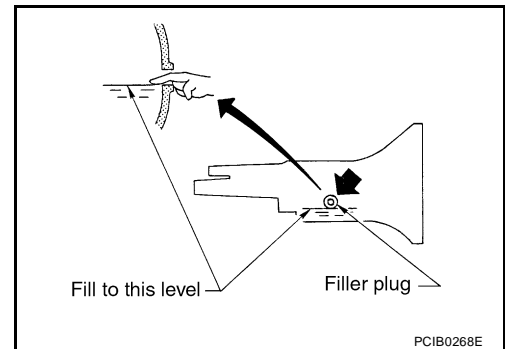

PCIB0268E

ELS001MS

Checking Transfer Fluid FLUID LEAKAGE AND FLUID LEVEL

1. Make sure that fluid is not leaking from the transfer assembly or around it.
2. Check fluid level from the filler plug hole as shown.

CAUTION:

Do not start engine while checking fluid level.

3. Install the filler plug with a new gasket to the transfer. Tighten to the specified torque. Refer to [TF-112, "COMPONENTS"](#).

CAUTION:

Do not reuse gasket.

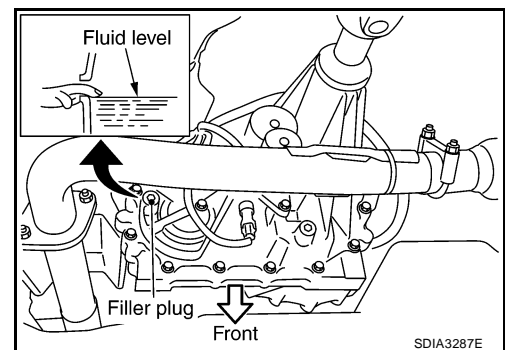

SDIA3287E

ELS001MT

Changing Transfer Fluid DRAINING

1. Stop engine.

A
B
C
D
E
F
G
H
I
J
K

MA

M

CHASSIS AND BODY MAINTENANCE

2. Remove the drain plug and gasket. Drain the fluid.
3. Install the drain plug with a new gasket to the transfer. Tighten to the specified torque. Refer to [TF-112, "COMPONENTS"](#) .

CAUTION:
Do not reuse gasket.

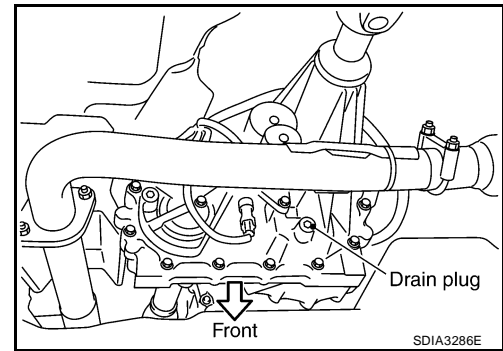

FILLING

1. Remove the filler plug and gasket.
2. Fill the transfer with new fluid until the fluid level reaches the specified limit near the filler plug hole.

Fluid grade and capacity : Refer to [MA-11, "Fluids and Lubricants"](#) .

CAUTION:
Carefully fill fluid. (Fill up for approx. 3 minutes.)

3. Leave the vehicle for 3 minutes, and check fluid level again.
4. Install the filler plug with a new gasket to the transfer. Tighten to the specified torque. Refer to [TF-112, "COMPONENTS"](#) .

CAUTION:
Do not reuse gasket.

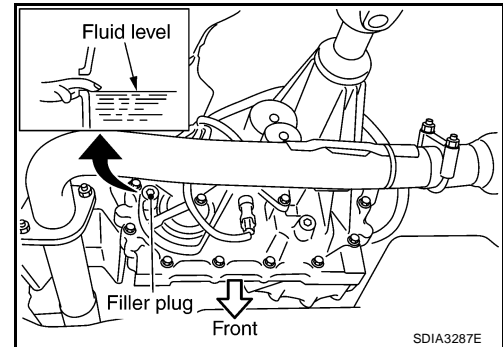

Checking Propeller Shaft

ELS001MU

Check the front and rear propeller shafts for damage, dents, and cracks. Check the joints for looseness and any damage. Repair or replace as necessary. Refer to [PR-3, "NVH Troubleshooting Chart"](#) .

Checking Front Final Drive Oil OIL LEAKAGE AND OIL LEVEL

ELS001MV

1. Make sure that oil is not leaking from the final drive assembly or around it.
2. Check oil level from the filler plug hole as shown.

CAUTION:
Do not start engine while checking oil level.

3. Install the filler plug with a new gasket on it to the final drive assembly. Tighten to the specified torque. Refer to [FFD-16, "COMPONENTS"](#) .

CAUTION:
Do not reuse gasket.

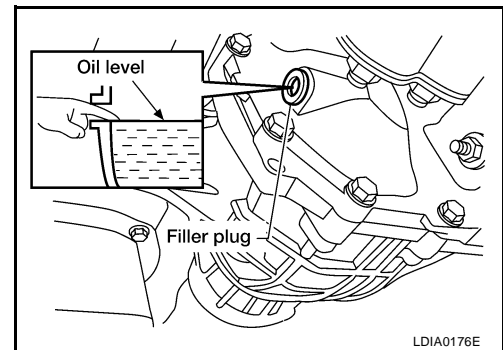

Changing Front Final Drive Oil DRAINING

ELS001MW

1. Stop the engine.

CHASSIS AND BODY MAINTENANCE

2. Remove the drain plug and gasket. Drain the gear oil.
3. Install the drain plug with a new gasket to the final drive assembly. Tighten to the specified torque. Refer to [FFD-16, "COMPONENTS"](#) .

CAUTION:

Do not reuse gasket.

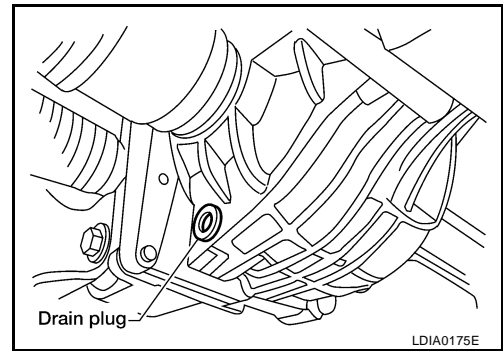

FILLING

1. Remove the filler plug and gasket. Fill with new gear oil until the oil level reaches the specified level near the filler plug hole.

Oil grade and capacity : Refer to [MA-11, "Fluids and Lubricants"](#) .

2. After refilling oil, check the oil level. Install the filler plug with a new gasket on it to the final drive assembly. Tighten to the specified torque. Refer to [FFD-16, "COMPONENTS"](#) .

CAUTION:

Do not reuse gasket.

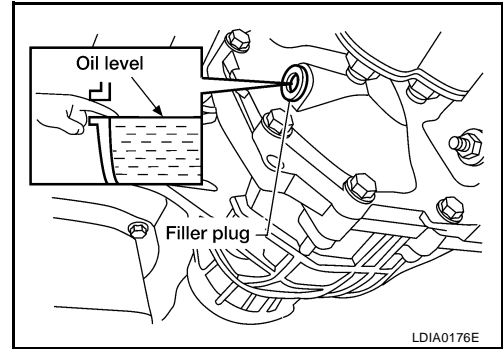

Checking Rear Final Drive Oil

CAUTION:

If using the vehicle for towing, the rear final drive oil must be replaced as specified. Refer to [MA-7, "PERIODIC MAINTENANCE"](#) .

NOTE:

The C200 is shown, the M226 (without electronic locking differential), and M226 (with electronic locking differential) are similar.

OIL LEAKAGE AND OIL LEVEL

1. Make sure that gear oil is not leaking from final drive assembly or around it.
2. Check oil level from filler plug hole as shown.

CAUTION:

Do not start engine while checking oil level.

3. Apply sealant to filler plug. Install filler plug to final drive assembly and tighten to the specified torque. Refer to [RFD-50, "COMPONENTS"](#) (C200), [RFD-50, "COMPONENTS"](#) (M226 without electronic locking differential), and [RFD-121, "COMPONENTS"](#) (M226 with electronic locking differential).

- Use Genuine Silicone RTV or equivalent. Refer to [GI-48, "Recommended Chemical Products and Sealants"](#) .

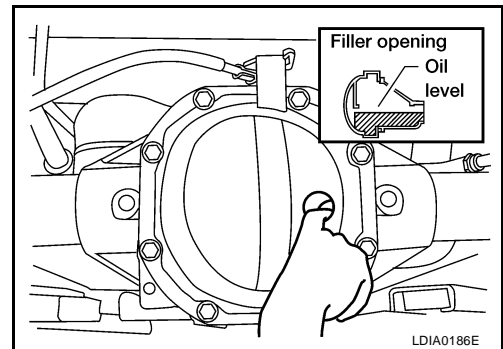

Changing Rear Final Drive Oil

CAUTION:

If using the vehicle for towing, the rear final drive oil must be replaced as specified. Refer to [MA-7, "PERIODIC MAINTENANCE"](#) .

NOTE:

The C200 is shown, the M226 (without electronic locking differential), and M226 (with electronic locking differential) are similar.

DRAINING

1. Stop engine.

CHASSIS AND BODY MAINTENANCE

2. Remove drain plug and drain gear oil.
3. Set a gasket on drain plug and install it to final drive assembly and tighten to the specified torque. Refer to [RFD-15, "COMPONENTS"](#) (C200), [RFD-50, "COMPONENTS"](#) (M226 without electronic locking differential), and [RFD-121, "COMPONENTS"](#) (M226 with electronic locking differential).

CAUTION:

Do not reuse gasket.

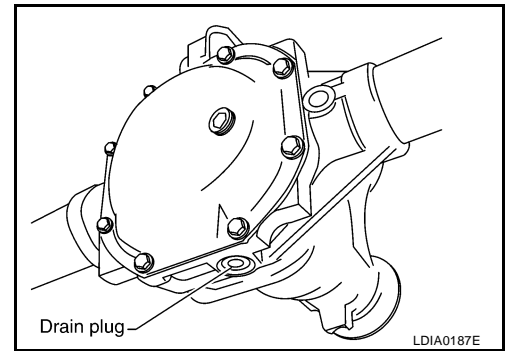

FILLING

1. Remove filler plug. Fill with new gear oil until oil level reaches the specified level near filler plug hole.

Oil grade and capacity : Refer to [MA-11, "Fluids and Lubricants"](#) .

2. After refilling oil, check oil level. Apply sealant to filler plug. Install filler plug to final drive assembly and tighten to the specified torque. Refer to [RFD-15, "COMPONENTS"](#) (C200), [RFD-50, "COMPONENTS"](#) (M226 without electronic locking differential), and [RFD-121, "COMPONENTS"](#) (M226 with electronic locking differential).

- Use Genuine Silicone RTV or equivalent. Refer to [GI-48, "Recommended Chemical Products and Sealants"](#) .

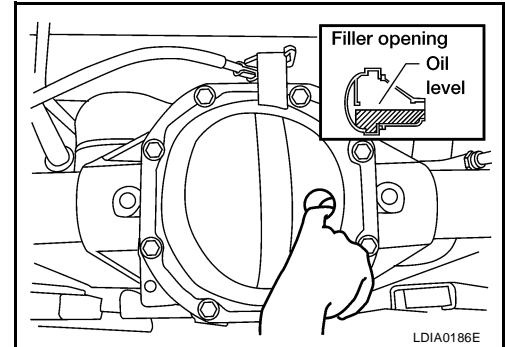

Balancing Wheels

WHEEL BALANCE ADJUSTMENT

NOTE:

If a wheel balance machine has adhesion balance weight mode settings and drive-in weight mode setting, select and adjust a drive-in weight mode suitable for the wheels.

1. Set the wheel on the wheel balance machine using the center hole as a guide. Start the wheel balance machine.
2. When the inner and outer imbalance values are shown on the wheel balance machine indicator, multiply the outer imbalance value by 1.6 to determine the balance weight that should be used. Select the outer balance weight with a value closest to the calculated value and install it to the designated outer position of, or at the designated angle in relation to the road wheel.

CAUTION:

- Do not install the inner balance weight before installing the outer balance weight.
- Before installing the balance weight, be sure to clean the mating surface of the wheel.

Indicated imbalance value $\times 5/3$ = balance weight to be installed

Calculation example:

$23 \text{ g (0.81 oz)} \times 5/3 = 38.33 \text{ g (1.35 oz)} = 40 \text{ g (1.41 oz)}$ balance weight (closer to calculated balance weight value)

Note that balance weight value must be closer to the calculated balance weight value.

Example:

$37.4 \text{ g} = 35 \text{ g (1.23 oz)}$

$37.5 \text{ g} = 40 \text{ g (1.41 oz)}$

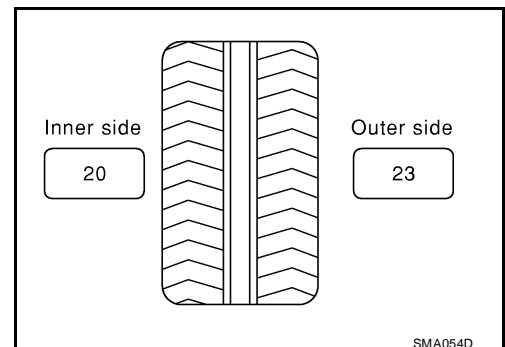

CHASSIS AND BODY MAINTENANCE

- a. Install balance weight in the position as shown.
- b. When installing the balance weight to the wheels, set it into the grooved area on the inner wall of the wheel as shown, so that the balance weight center is aligned with the wheel balance machine indication position (angle).

CAUTION:

- Always use Genuine NISSAN adhesion balance weights.
- Balance weights are not reusable; always replace the old ones with new ones.
- Do not install more than three sheets of balance weights.

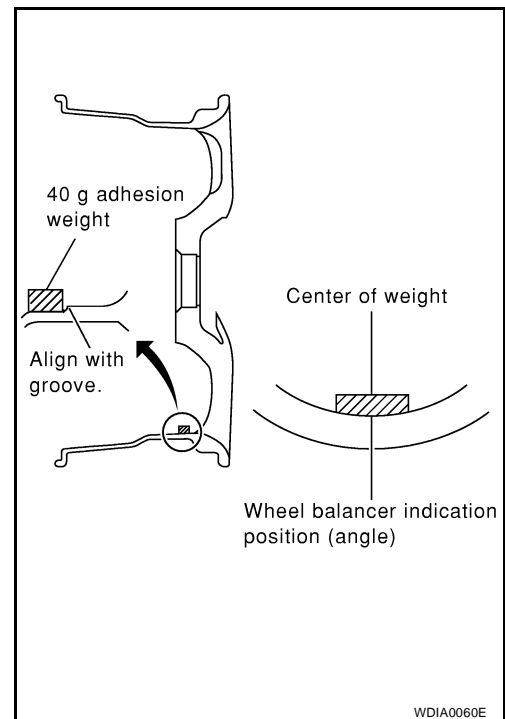

- c. If the calculated balance weight value exceeds 50 g (1.76 oz), install two balance weight sheets in line with each other as shown.

CAUTION:

Do not install one balance weight sheet on top of another.

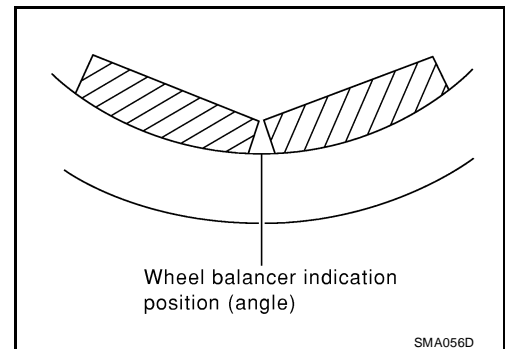

3. Start the wheel balance machine again.
4. Install the drive-in balance weight on the inner side of the road wheel in the wheel balance machine indication position (angle).

CAUTION:

Do not install more than two balance weights.

5. Start the wheel balance machine. Make sure that the inner and outer residual imbalance values are 5g (0.18 oz) each or below.
 - If either the inner or outer residual imbalance value exceeds 5 g (0.18 oz), repeat the tire installation procedure.

CHASSIS AND BODY MAINTENANCE

Wheel Balance (Maximum Allowable Imbalance)

Maximum allowable imbalance	Dynamic (At rim flange)	5 g (0.18 oz) (one side)
	Static	10 g (0.35 oz)

Tire Rotation

ELS001N0

1. Rotate the tires on each side from front to back as shown, using power tool.

Wheel nuts : Refer to [WT-6, "WHEEL AND TIRE ASSEMBLY"](#) .

- Follow the maintenance schedule for tire rotation maintenance intervals. Refer to [MA-5, "GENERAL MAINTENANCE"](#) .
- Do not include the spare tire when rotating the tires.

CAUTION:

When installing the wheels, tighten the wheel nuts diagonally by repeating the tightening pattern two or three times in order to prevent the wheels from developing any distortion.

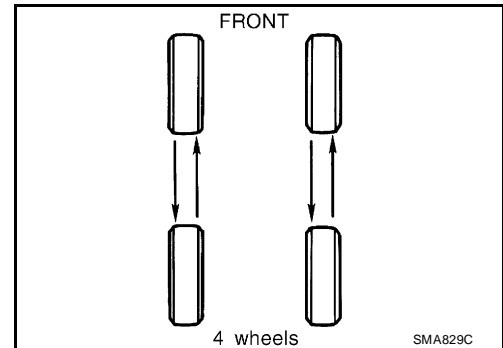

2. Adjust the tire pressure to specification. Refer to [WT-34, "Tire"](#) .
3. After the tire rotation, retighten the wheel nuts after the vehicle has been driven for 1,000 km (600 miles), and also after a wheel and tire have been installed such as after repairing a flat tire.

Checking Brake Fluid Level and Leaks

ELS001N1

- Check the brake fluid level in the reservoir tank. It should be between the "MAX" and "MIN" lines on the reservoir tank.
- If the fluid level is extremely low, check the brake system.
- If the brake warning lamp comes on when the fluid is at the correct level, check the brake fluid level switch and the parking brake switch.

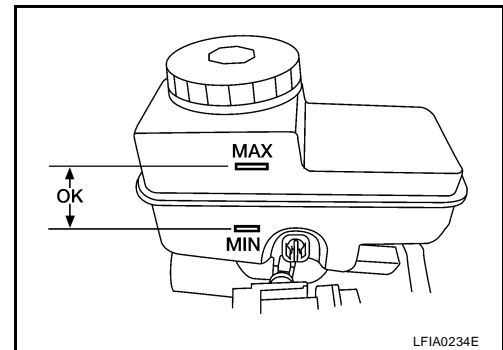

Checking Brake Lines and Cables

ELS001N2

1. Check the brake lines and hoses for cracks, deterioration, and other damage. Replace any damaged parts.

CAUTION:

If brake fluid leaks are visible around the brake line joints, retighten the joint, or replace damaged parts as necessary.

2. Check for brake fluid leaks by fully depressing brake pedal while engine is running.

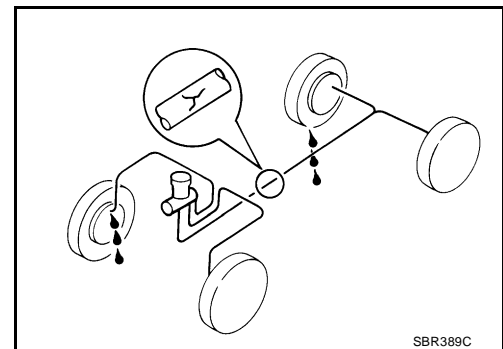

CHASSIS AND BODY MAINTENANCE

Checking Disc Brake

ELS001N3

ROTOR

Check the condition of the rotor, and for any wear or damage. Repair or replace as necessary.

Standard thickness : Refer to [BR-21, "FRONT DISC BRAKE"](#), [BR-28, "REAR DISC BRAKE"](#).

Repair limit thickness : Refer to [BR-21, "FRONT DISC BRAKE"](#), [BR-28, "REAR DISC BRAKE"](#).

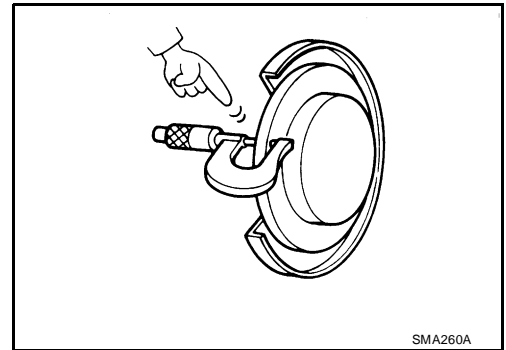

SMA260A

CALIPER

Check for any fluid leakage. Repair as necessary.

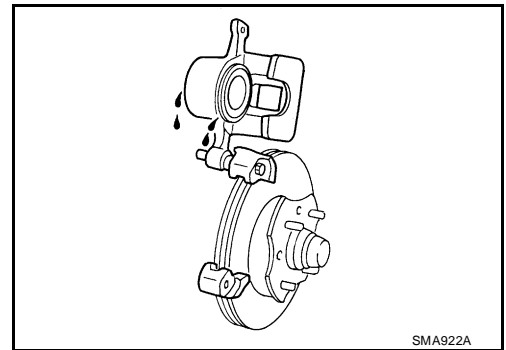

SMA922A

PAD

Check for any wear or damage. Repair or replace as necessary.

Standard thickness : Refer to [BR-21, "FRONT DISC BRAKE"](#), [BR-28, "REAR DISC BRAKE"](#).

Repair limit thickness : Refer to [BR-21, "FRONT DISC BRAKE"](#), [BR-28, "REAR DISC BRAKE"](#).

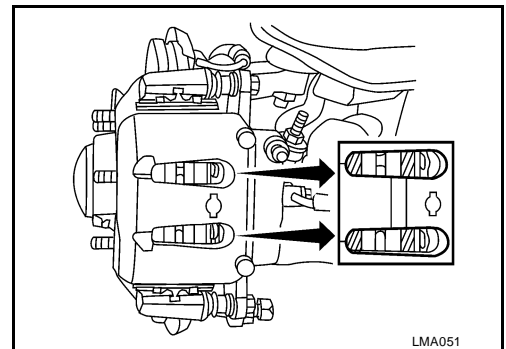

LMA051

Checking Steering Gear and Linkage

ELS001N4

STEERING GEAR

- Check the steering gear housing for looseness, damage and oil leakage as shown.
- Check the steering column connections for looseness.

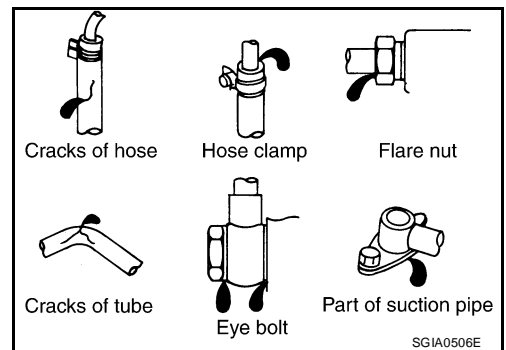

Cracks of hose

Hose clamp

Flare nut

Cracks of tube

Eye bolt

Part of suction pipe

SGIA0506E

STEERING LINKAGE

- Check the ball joint, dust cover and other component parts for looseness, wear, damage and grease leakage.

A
B
C
D
E
F
G
H
I
J
K
MA
M

CHASSIS AND BODY MAINTENANCE

Checking Power Steering Fluid and Lines

ELS001N5

CHECKING FLUID LEVEL

- Check the power steering fluid level with the engine off.
- Check fluid level on reservoir. Use "HOT" range at fluid temperatures of 50° to 80°C (122° to 176°F). Use "COLD" range at fluid temperatures of 0° to 30°C (32° to 86°F).

CAUTION:

- Do not overfill.
- Fill with the recommended fluid or equivalent. Refer to [MA-11, "Fluids and Lubricants"](#) .

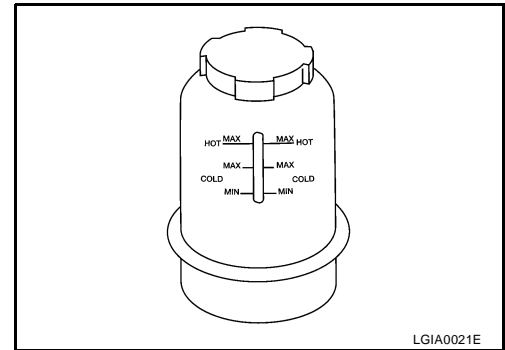

CHECKING LINES

- Check lines for improper attachment, leaks, cracks, damage, loose connections, chafing and deterioration.

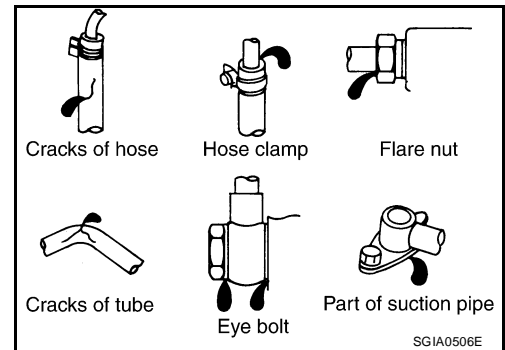

Checking Axle and Suspension Parts FRONT AND REAR AXLE AND SUSPENSION PARTS

ELS001N6

Check front and rear axle and suspension parts for excessive play, cracks, wear or other damage.

- Shake each wheel to check for excessive play.
- Rotate each wheel to check for abnormal noise.
- Check axle and suspension nuts and bolts for looseness.

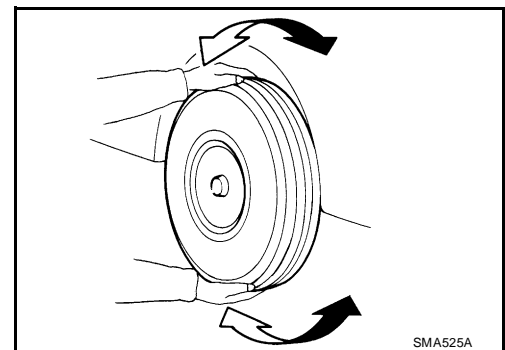

- Check the strut and shock absorber for oil leakage or other damage.
- Check suspension ball joints for grease leakage and ball joint dust cover for cracks or other damage.

FRONT DRIVE SHAFT

Check the boots and drive shaft for cracks, wear, damage, and grease leakage.

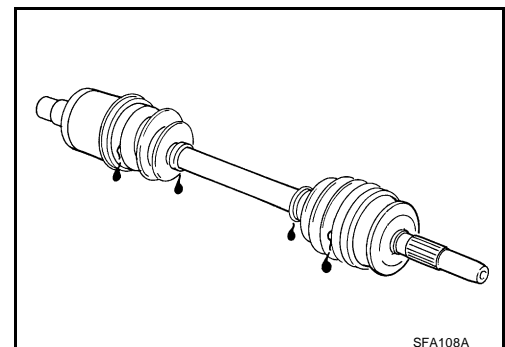

CHASSIS AND BODY MAINTENANCE

Lubricating Locks, Hinges and Hood Latches

ELS00111

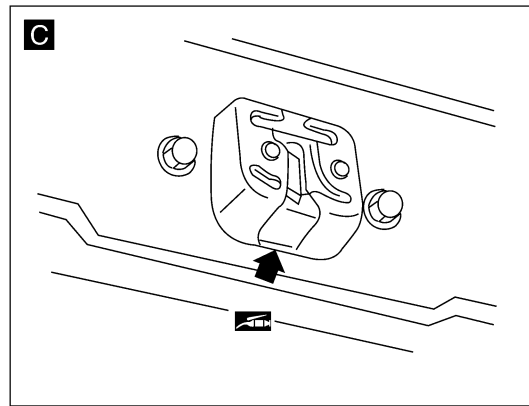
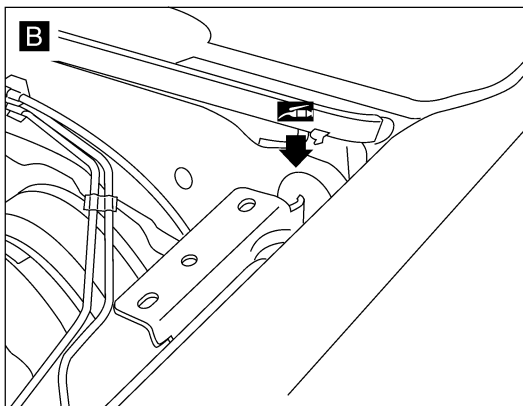
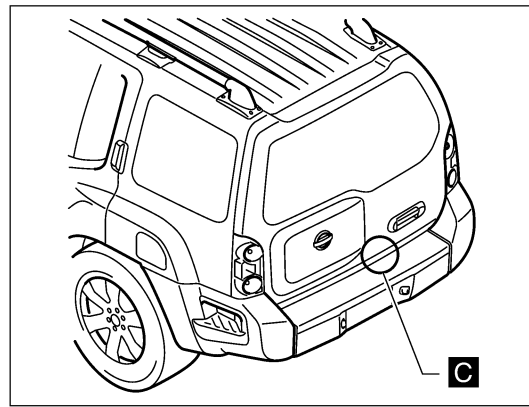
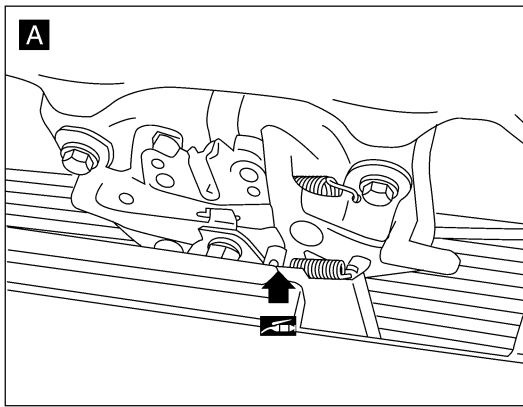
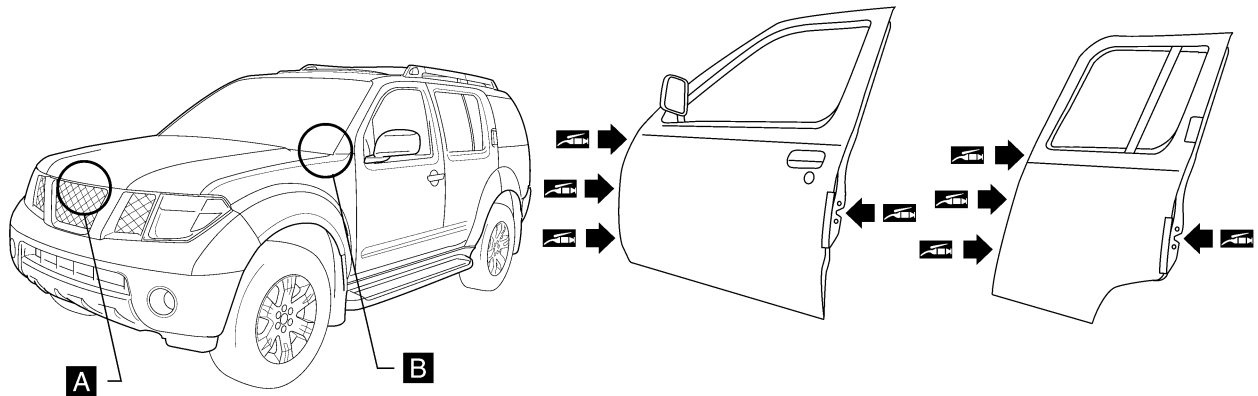

- Lubricate the locations shown. Refer to [MA-11, "Fluids and Lubricants"](#).

WLIA0028E

A
B
C
D
E
F
G
H
I
J
K
MA
M

CHASSIS AND BODY MAINTENANCE

Checking Seat Belts, Buckles, Retractors, Anchors and Adjusters

ELS001J

Check the seat belt buckles, webbing, retractors, anchors and adjusters. Replace any seat belt assembly as necessary. Refer to [SB-8, "Seat Belt Inspection"](#).

- Check the seat belt anchors for loose mounting bolts, damage, or excessive wear.
- Check the seat belt webbing for any damage, cuts, fraying, or excessive wear.
- Check the retractor for smooth operation.
- Check the function of the buckles by inserting the seat belt tongue and checking for proper engagement of the buckle and press the button on the buckle to check for proper release of the seat belt tongue.

CAUTION:

- **After any collision, inspect all seat belt assemblies, including retractors and other attached components, such as the guide rail set. NISSAN recommends replacing all seat belt assemblies in use during a collision, unless they are not damaged and are inspected to confirm they are operating properly after a minor collision.**
Also inspect all seat belt assemblies that are not in use during a collision, and replace any components if damaged or not operating properly. The seat belt pre-tensioner should be replaced even if the seat belts are not in use during a frontal collision where the driver and passenger air bags have been deployed.
- **If any component of the seat belt assembly is suspected of being damaged or not operating properly, do not repair the component. Replace the components as an assembly.**
- **If the seat belt webbing is cut, frayed, or damaged then replace the seat belt assembly.**
- **Never lubricate the seat belt buckle or tongue.**
- **When replacing any seat belt assembly always use a Genuine NISSAN seat belt assembly.**