

SECTION **PR**
PROPELLER SHAFT

A
B
C

PR

CONTENTS

E

PREPARATION	2	REAR PROPELLER SHAFT	9	F
Commercial Service Tools	2	On-Vehicle Service	9	
NOISE, VIBRATION, AND HARSHNESS (NVH)		APPEARANCE AND NOISE INSPECTION	9	
TROUBLESHOOTING	3	PROPELLER SHAFT VIBRATION	9	G
NVH Troubleshooting Chart	3	Removal and Installation	10	
FRONT PROPELLER SHAFT	4	COMPONENTS	10	
On-Vehicle Service	4	REMOVAL	11	H
APPEARANCE AND NOISE INSPECTION	4	INSPECTION	11	
PROPELLER SHAFT VIBRATION	4	INSTALLATION	12	
Removal and Installation	5	Disassembly and Assembly	13	
COMPONENTS	5	DISASSEMBLY	13	I
REMOVAL	5	ASSEMBLY	14	
INSPECTION	6	SERVICE DATA AND SPECIFICATIONS (SDS)	15	J
INSTALLATION	6	General Specifications	15	
Disassembly and Assembly	6	Snap Ring	16	
DISASSEMBLY	6			K
ASSEMBLY	7			L

M

PREPARATION

PREPARATION

PF0:00002

Commercial Service Tools

EDS0032M

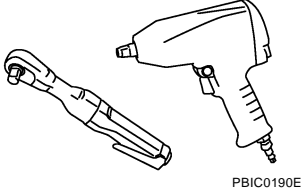
Tool name	Description
<p data-bbox="154 298 267 325">Power tool</p>  <p data-bbox="862 516 933 535">PBIC0190E</p>	<p data-bbox="1010 298 1258 325">Loosening bolts and nuts</p>

NOISE, VIBRATION, AND HARSHNESS (NVH) TROUBLESHOOTING

NOISE, VIBRATION, AND HARSHNESS (NVH) TROUBLESHOOTING

PF0:00003

NVH Troubleshooting Chart

EDS0032N

Use the chart below to help you find the cause of the symptom. If necessary, repair or replace these parts.

Reference page		PR-4 (front) PR-9 (rear)	PR-4 (front) PR-9 (rear)	PR-4 (front) PR-9 (rear)	FFD-6, "NVH Troubleshooting Chart" RFD-8, "NVH Troubleshooting Chart"	FAX-4, "NVH Troubleshooting Chart" RAX-5, "NVH Troubleshooting Chart"	FSU-4, "NVH Troubleshooting Chart" RSU-4, "NVH Troubleshooting Chart"	WT-4, "NVH Troubleshooting Chart"	WT-4, "NVH Troubleshooting Chart"	FAX-4, "NVH Troubleshooting Chart"	BR-5, "NVH Troubleshooting Chart"	PS-5, "NVH Troubleshooting Chart"
Possible cause and suspected parts		Uneven rotation torque	Rotation imbalance	Excessive run out	Differential	Axle	Suspension	Tires	Road wheel	Drive shaft	Brakes	Steering
Symptom	Noise	x	x	x	x	x	x	x	x	x	x	x
	Shake					x	x	x	x	x	x	x
	Vibration	x	x	x		x	x	x		x		x

x: Applicable

A
B
C
PR
E
F
G
H
I
J
K
L
M

FRONT PROPELLER SHAFT

FRONT PROPELLER SHAFT

PFP:37200

On-Vehicle Service

EDS00320

APPEARANCE AND NOISE INSPECTION

- Check the propeller shaft tube surface for dents or cracks. If damaged, replace the propeller shaft assembly.
- Check the bearings for noise and damage. Repair or replace the bearings as necessary.

PROPELLER SHAFT VIBRATION

If a vibration is present at high speed, inspect the propeller shaft runout first.

1. Measure the runout of the propeller shaft tube at several points by rotating the final drive companion flange with your hands.

Propeller shaft runout limit : 0.6 mm (0.024 in) or less

2. If the runout exceeds specifications, disconnect the propeller shaft at the final drive companion flange; then rotate the companion flange 90°, 180° and 270° and reconnect the propeller shaft.
3. Check the runout again. If the runout still exceeds specifications, replace the propeller shaft assembly.
4. After installation, check for vibration by driving the vehicle.

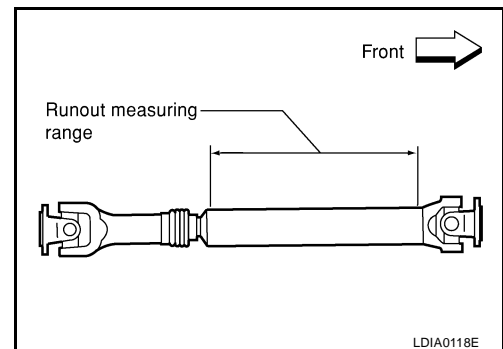
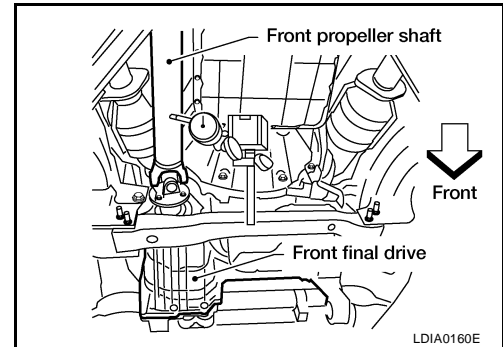

FRONT PROPELLER SHAFT

EDS0032P

Removal and Installation COMPONENTS

Model 2F1310

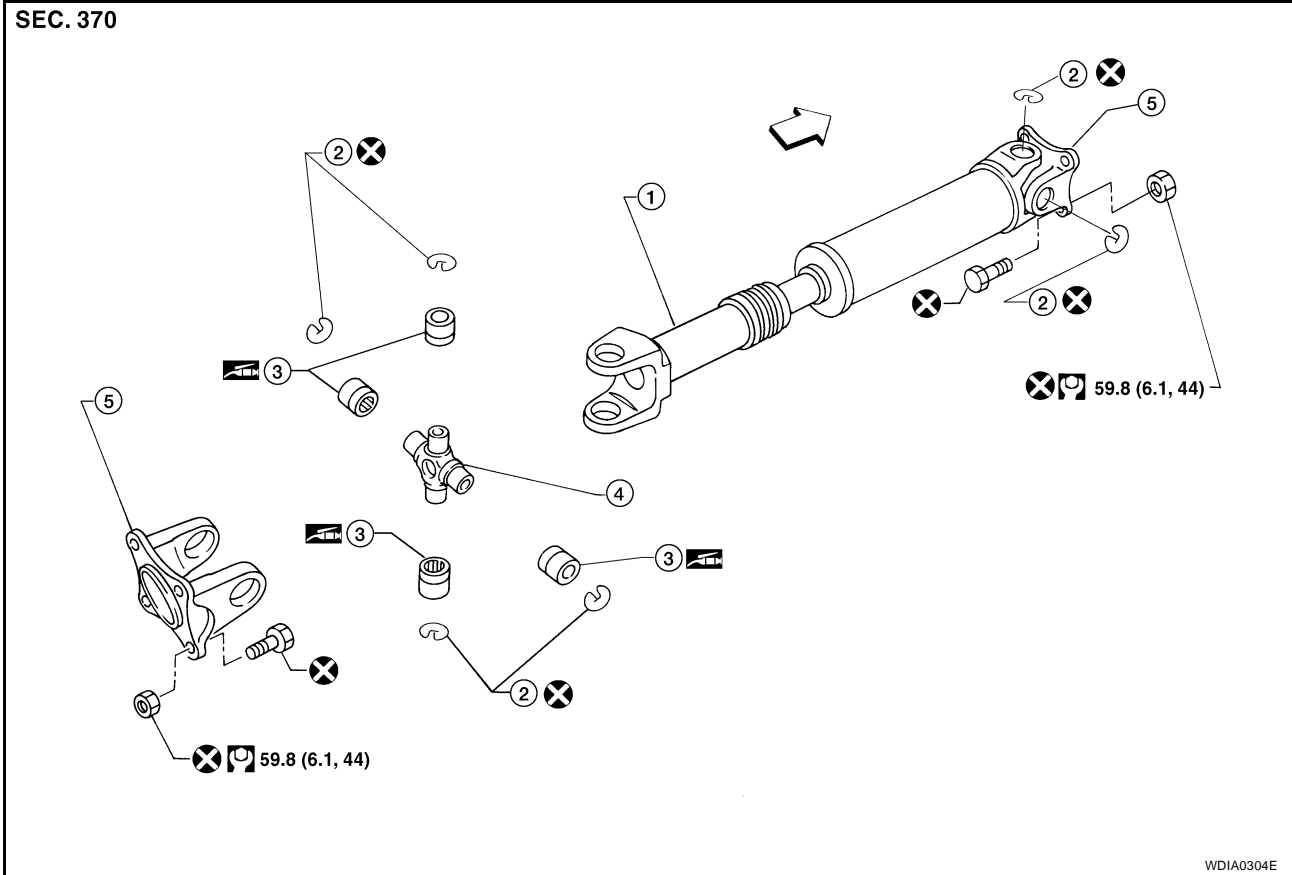

- | | | |
|-------------------------|----------------|--------------------|
| 1. Propeller shaft tube | 2. Snap ring | 3. Journal bearing |
| 4. Journal | 5. Flange yoke | ⇐: Vehicle front |

REMOVAL

1. Remove the undercover using power tool.
2. Put matching marks on the front propeller shaft flange yoke and the front final drive companion flange as shown.

CAUTION:

For matching marks, use paint. Never damage the flange yoke and companion flange of the front final drive.

3. Put matching marks on the front propeller shaft flange yoke and the transfer companion flange.

CAUTION:

For matching marks, use paint. Never damage the flange yoke and companion flange of the front final drive.

4. Remove the bolts and then remove the front propeller shaft from the front final drive and transfer.

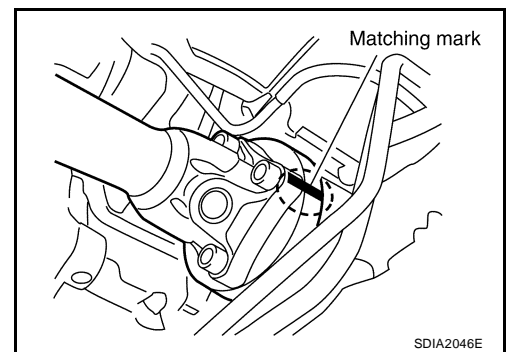

FRONT PROPELLER SHAFT

INSPECTION

- Inspect the propeller shaft runout. If runout exceeds the limit, replace the propeller shaft assembly.

Runout limit : 0.6 mm (0.024 in) or less

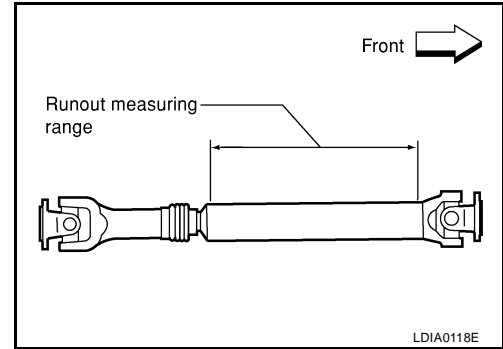

- While holding the flange yoke on one side, check axial play of the joint as shown. If the journal axial play exceeds the specification, repair or replace the journal parts.

Journal axial play : 0.02 mm (0.0008 in) or less

- Check the propeller shaft tube surface for dents or cracks. If damage is detected, replace the propeller shaft assembly.

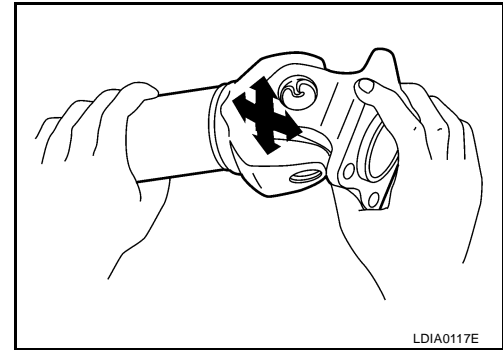

INSTALLATION

Installation is in the reverse order of removal.

- After installation, check for vibration by driving the vehicle. Refer to [PR-3, "NVH Troubleshooting Chart"](#).

CAUTION:

Do not reuse the bolts and nuts. Always install new ones.

Disassembly and Assembly

DISASSEMBLY

EDS0032Q

Journal

1. Put matching marks on the front propeller shaft and flange yoke as shown.

CAUTION:

For matching marks, use paint. Never damage the front propeller shaft or flange yoke.

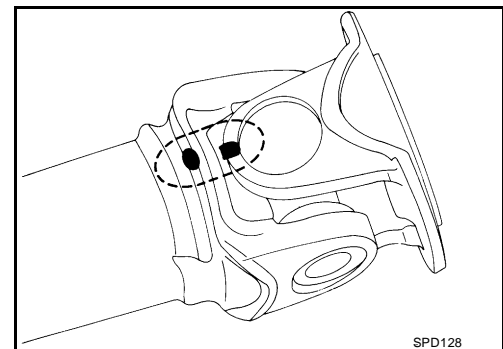

2. Remove the snap rings.

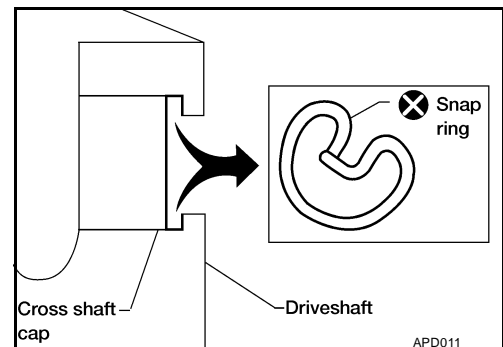

FRONT PROPELLER SHAFT

3. Push out and remove the journal bearings by lightly tapping the flange yoke with a hammer, taking care not to damage the journal or flange yoke hole.

NOTE:

Put marks on the disassembled parts so that they can be reinstalled in their original positions from which they were removed.

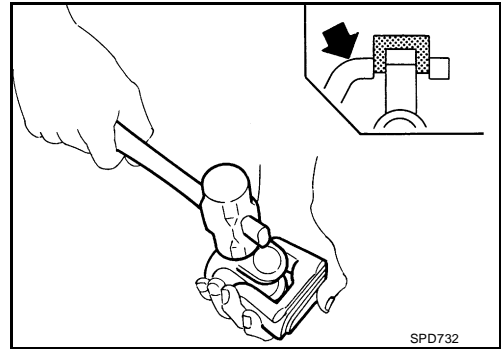

4. Push out and remove the remaining journal bearings at the opposite side by lightly tapping the flange yoke with a hammer, taking care not to damage the journal or flange yoke hole.

NOTE:

Put marks on the disassembled parts so that they can be reinstalled in their original positions from which they were removed.

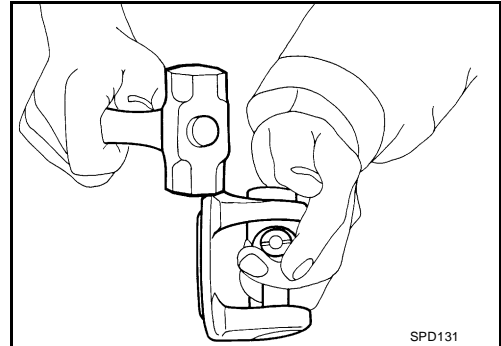

ASSEMBLY

Journal

1. Assemble the journal bearings. Apply multipurpose grease on the bearing inner surface.

NOTE:

During assembly, use caution so that the needle bearings do not fall down.

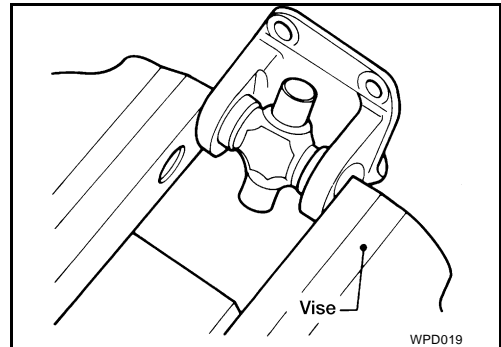

2. Select snap rings that will provide the specified play in an axial direction of the journal, and install them. Refer to [PR-16, "Snap Ring"](#).

NOTE:

Select snap rings with a difference in thickness at both sides within 0.02 mm (0.0008 in).

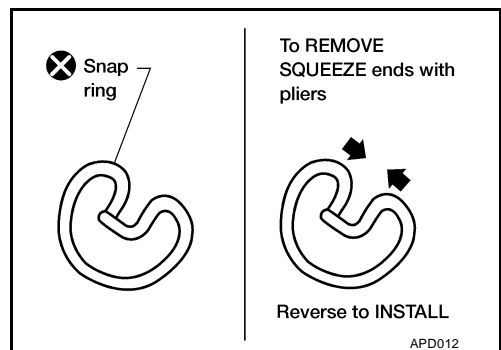

A
B
C
PR
E
F
G
H
I
J
K
L
M

FRONT PROPELLER SHAFT

3. Adjust the thrust clearance between the bearing and snap ring to zero by tapping the yoke.

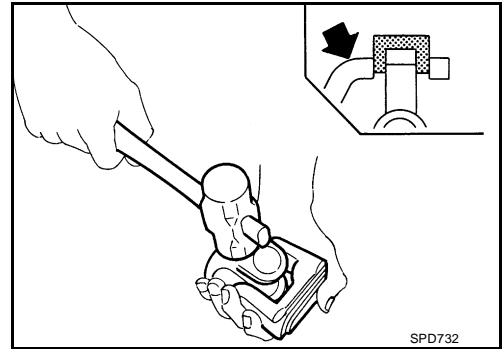

4. Make sure that the journal moves smoothly and is below the joint flex effort specification.

Joint flex effort : 1.96 N·m (0.20 kg·m, 17 in·lb) or less

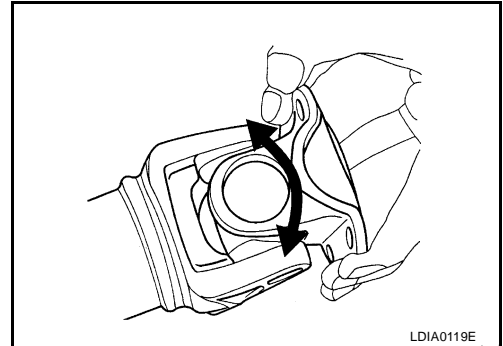

REAR PROPELLER SHAFT

PFP:37000

REAR PROPELLER SHAFT

On-Vehicle Service

EDS0032R

APPEARANCE AND NOISE INSPECTION

Check the propeller shaft tube surface for dents or cracks. If damaged, replace the propeller shaft assembly.

PROPELLER SHAFT VIBRATION

If a vibration is present at high speed, inspect the propeller shaft runout first.

1. Measure the runout of the propeller shaft tube at several points by rotating the final drive companion flange with your hands.

Propeller shaft runout limit

2WD : 1.02 mm (0.040 in) or less

4WD : 0.6 mm (0.024 in) or less

2. If the runout exceeds specifications, disconnect the propeller shaft at the final drive companion flange; then rotate the companion flange 90°, 180° and 270° and reconnect the propeller shaft.
3. Check the runout again. If the runout still exceeds specifications, replace the propeller shaft assembly.
4. After installation, check for vibration by driving vehicle.

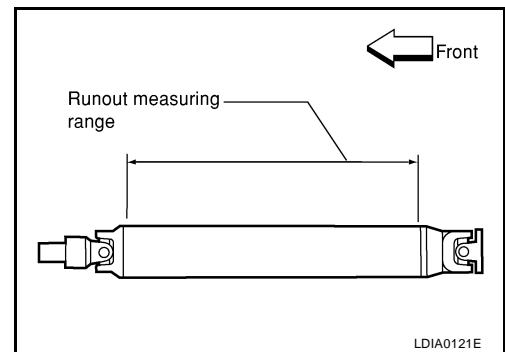
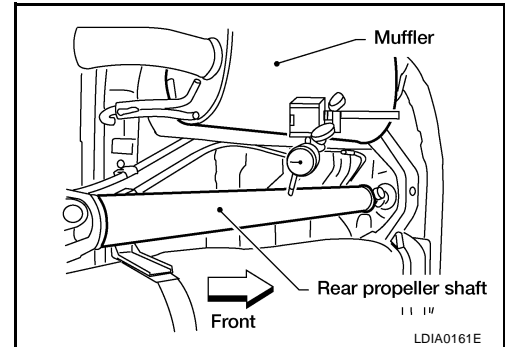

A
B
C
PR
E
F
G
H
I
J
K
L
M

REAR PROPELLER SHAFT

EDS0032S

Removal and Installation COMPONENTS

Model 2S1330

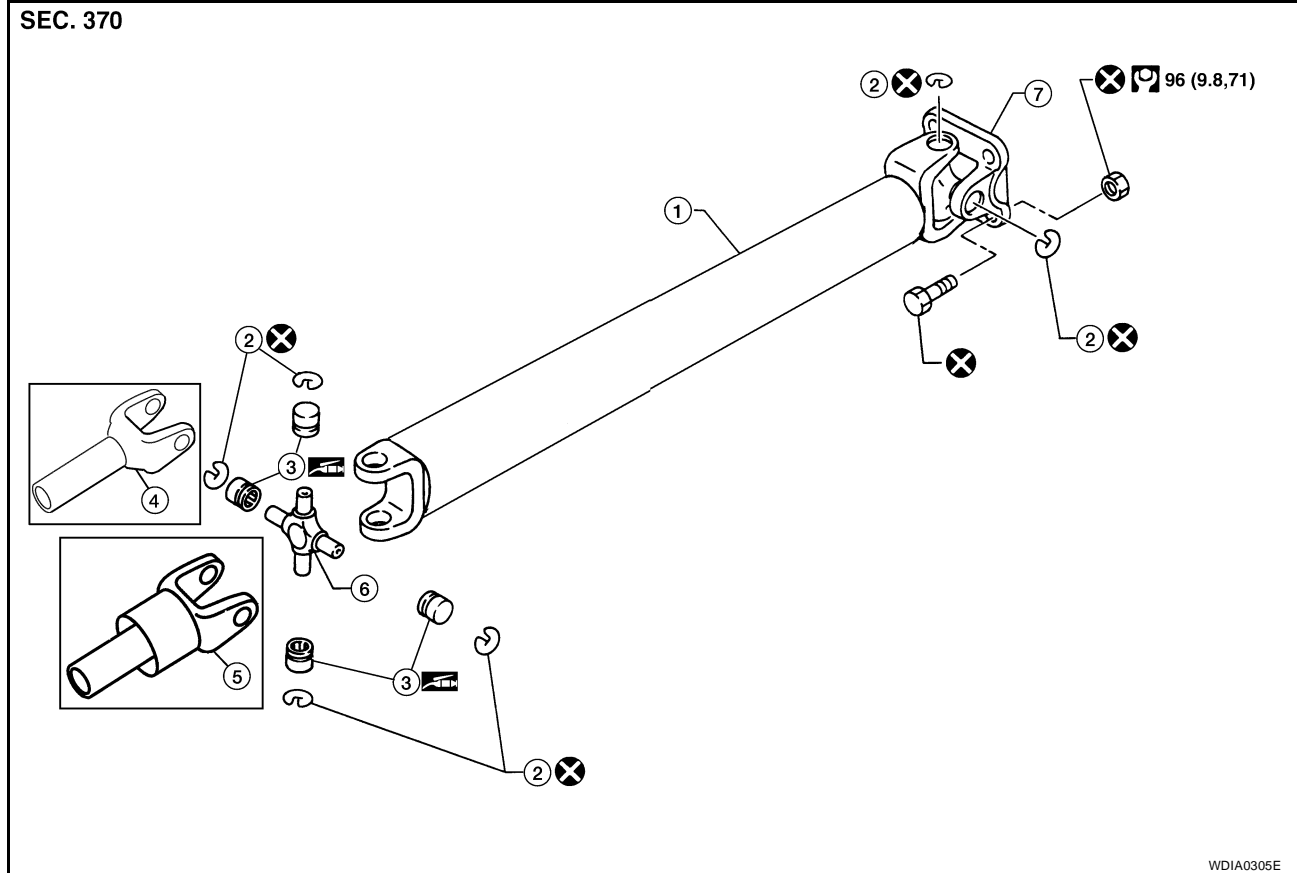

- | | | |
|-----------------------------|-----------------------------|--------------------|
| 1. Propeller shaft | 2. Snap ring | 3. Journal bearing |
| 4. Sleeve yoke (M/T models) | 5. Sleeve yoke (A/T models) | 6. Journal |
| 7. Flange yoke | | |

REAR PROPELLER SHAFT

Model 2S1330-BJ100

SEC. 370

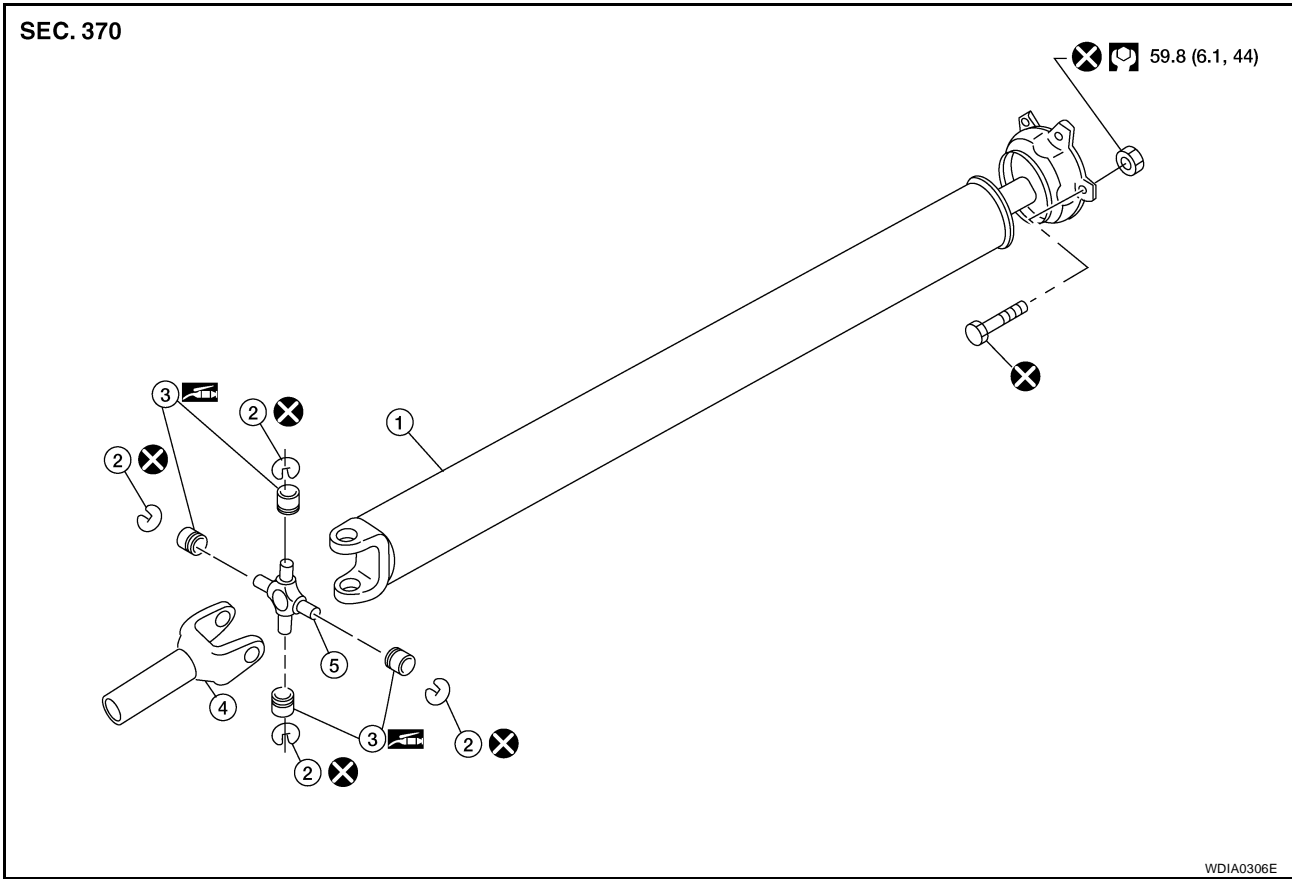

- | | | |
|--------------------|--------------|--------------------|
| 1. Propeller shaft | 2. Snap ring | 3. Journal bearing |
| 4. Sleeve yoke | 5. Journal | |

REMOVAL

- Put the transmission in neutral and release the parking brake.
- Put matching marks on the rear propeller shaft flange yoke and the rear final drive companion flange as shown.

CAUTION:

For matching marks, use paint. Never damage the rear propeller shaft flange yoke or the companion flange.

- Remove the bolts, then remove the propeller shaft from the rear final drive and transmission or transfer.

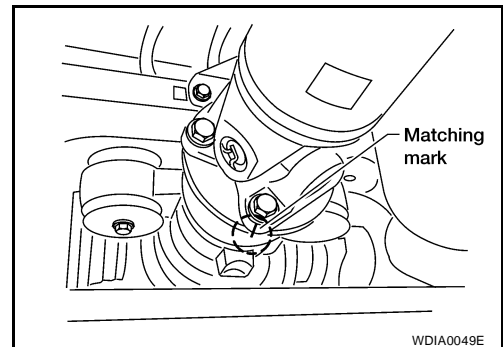

INSPECTION

- Inspect the propeller shaft runout. If runout exceeds the limit, replace the propeller shaft assembly.

Propeller shaft runout limit

2WD : 1.02 mm (0.040 in) or less

4WD : 0.6 mm (0.024 in) or less

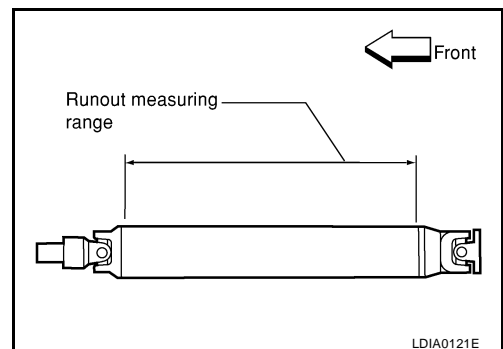

A
B
C
PR
E
F
G
H
I
J
K
L
M

REAR PROPELLER SHAFT

- While holding the flange yoke on one side, check axial play of the joint as shown. If the journal axial play exceeds the specification, repair or replace the journal parts.

Journal axial play : 0.02 mm (0.0008 in) or less

- Check the propeller shaft for dents or cracks. If damage is detected, replace the propeller shaft assembly.

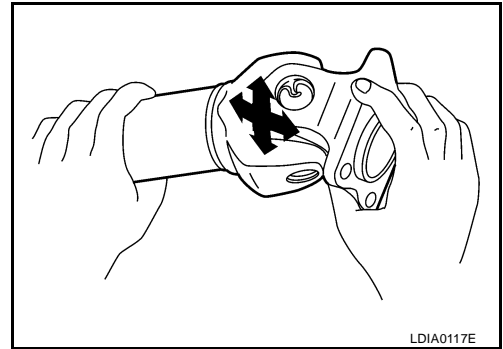

INSTALLATION

Installation is in the reverse order of removal.

- After installation, check for vibration by driving the vehicle. Refer to [PR-3, "NVH Troubleshooting Chart"](#).

CAUTION:

Do not reuse the bolts and nuts. Always install new ones.

REAR PROPELLER SHAFT

EDS0032T

Disassembly and Assembly DISASSEMBLY

Journal

1. Put matching marks on the rear propeller shaft and flange yoke as shown.

CAUTION:

For matching marks use paint. Never damage the rear propeller shaft or flange yoke.

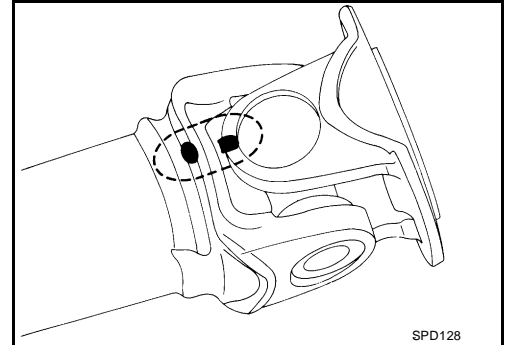

2. Remove the snap rings.

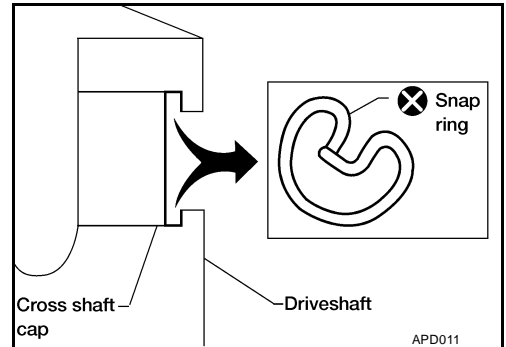

3. Push out and remove the journal bearings by lightly tapping the flange yoke with a hammer, taking care not to damage the journal or flange yoke hole.

NOTE:

Put marks on the disassembled parts so that they can be reinstalled in their original positions from which they were removed.

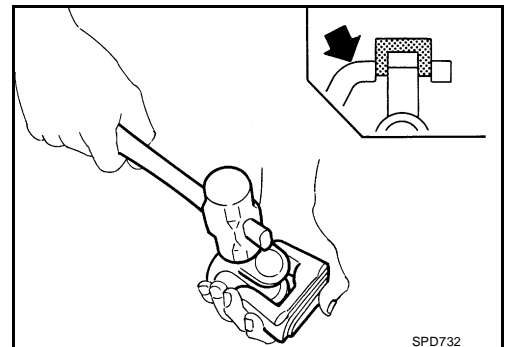

4. Push out and remove the remaining journal bearings at the opposite side by lightly tapping the flange yoke with a hammer, taking care not to damage the journal or flange yoke hole.

NOTE:

Put marks on the disassembled parts so that they can be reinstalled in their original positions from which they were removed.

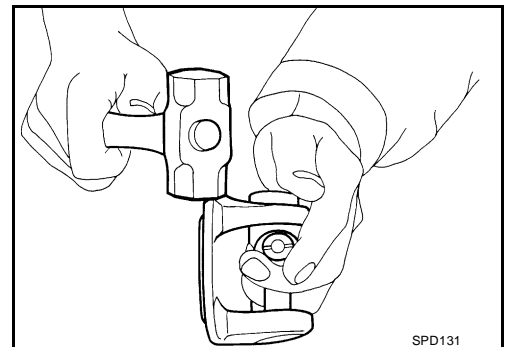

A
B
C
PR
E
F
G
H
I
J
K
L
M

REAR PROPELLER SHAFT

ASSEMBLY

Journal

1. Assemble the journal bearings. Apply multipurpose grease on the bearing inner surface.

NOTE:

During assembly, use caution so that the needle bearings do not fall down.

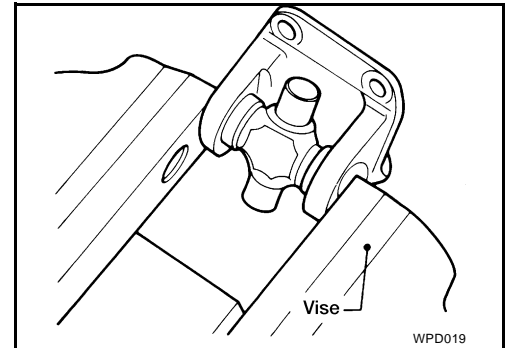

2. Select snap rings that will provide the specified play in an axial direction of the journal, and install them. Refer to [PR-16, "Snap Ring"](#).

NOTE:

Select snap rings with a difference in thickness at both sides within 0.02 mm (0.0008 in).

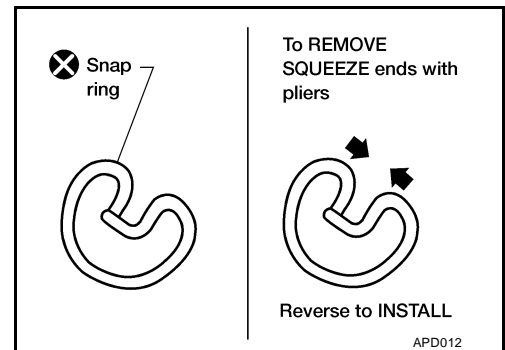

3. Adjust the thrust clearance between the bearing and snap ring to zero by tapping the yoke.

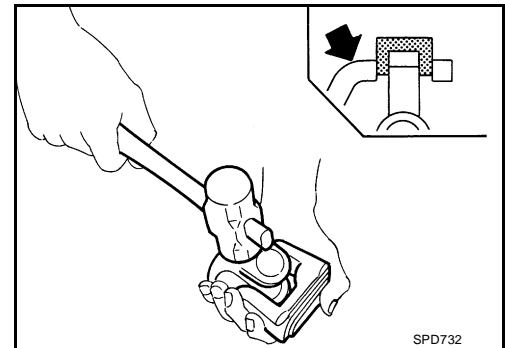

4. Make sure that the journal moves smoothly and is below the joint flex effort specification.

Joint flex effort : 2.26 N-m (0.23 kg-m, 20 in-lb) or less

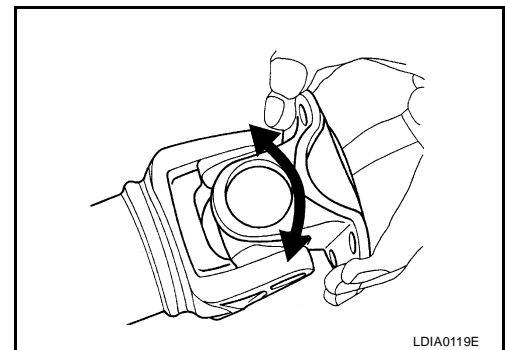

SERVICE DATA AND SPECIFICATIONS (SDS)

SERVICE DATA AND SPECIFICATIONS (SDS)

PF0:00030

General Specifications 2WD Model

EDS0032U

Applied model	VQ40DE	
	M/T	A/T
Propeller shaft model	2S1330 (aluminum)	
Number of joints	2	
Coupling method with rear final drive	Flange type	
Coupling method with transmission	Sleeve type	
Shaft length (Spider to spider)	1178.8 mm (46.41 in)	1262.80 (49.72 in)
Shaft outer diameter	102.5 mm (4.00 in)	
Journal axial play	0.02 mm (0.0008 in) or less	
Propeller shaft runout limit	1.02 mm (0.040 in) or less	
Propeller shaft joint flex effort	2.26 N·m (0.23 kg·m, 20 in·lb) or less	

4WD Model

Applied model		VQ40DE	
		C200	M226
Front	Propeller shaft model	2F1310	
	Number of joints	2	
	Coupling method with front final drive	Flange type	
	Coupling method with transfer	Flange type	
	Shaft length (Spider to spider)	696 mm (27.40 in)	
	Shaft outer diameter	63.5 mm (2.50 in)	
	Journal axial play	0.02 mm (0.0008 in) or less	
	Propeller shaft runout limit	0.6 mm (0.024 in) or less	
	Propeller shaft joint flex effort	1.96 N·m (0.20 kg·m, 17 in·lb) or less	
Rear	Propeller shaft model	2S1330-BJ100 (steel)	
	Number of joints	2	
	Coupling method with rear final drive	Flange type	
	Coupling method with transmission	Sleeve type	
	Shaft length (Spider to spider)	804.9 mm (31.69 in)	774.9 mm (30.51 in)
	Shaft outer diameter	76.2 mm (3.00 in)	
	Journal axial play	0.02 mm (0.0008 in) or less	
	Propeller shaft runout limit	0.6 mm (0.024 in) or less	
	Propeller shaft joint flex effort	2.26 N·m (0.23 kg·m, 20 in·lb) or less	

SERVICE DATA AND SPECIFICATIONS (SDS)

Snap Ring

Model 2F1310, 2S1330-BJ100 (steel)

EDS0032V

Unit: mm (in)

Thickness	Color	Part Number*
1.99 (0.0783)	White	37146-C9400
2.02 (0.0795)	Yellow	37147-C9400
2.05 (0.0807)	Red	37148-C9400
2.08 (0.0819)	Green	37149-C9400
2.11 (0.0831)	Blue	37150-C9400
2.14 (0.0843)	Light brown	37151-C9400
2.17 (0.0854)	Black	37152-C9400
2.20 (0.0866)	No paint	37153-C9400

*Always check with the Parts Department for the latest parts information.

Model 2S1330 (aluminum)

Unit: mm (in)

Thickness	Color	Part Number*
1.499 - 1.537 (0.0590 - 0.0605)	Black	37146-EA500
1.524 - 1.562 (0.0600 - 0.0615)	Black	37147-EA500
1.549 - 1.588 (0.0610 - 0.0625)	Black	37148-EA500
1.600 - 1.638 (0.0630 - 0.0645)	Black	37149-EA500

*Always check with the Parts Department for the latest parts information.