

A
CO
C
D
E
F
G
H
I
J
K
L
M
N
O
P

SECTION CO

ENGINE COOLING SYSTEM

CONTENTS

<p style="text-align: center;">VQ40DE</p> <p>PRECAUTION 2</p> <p>PRECAUTIONS 2</p> <p style="padding-left: 20px;">Precaution for Supplemental Restraint System (SRS) "AIR BAG" and "SEAT BELT PRE-TENSIONER"2</p> <p style="padding-left: 20px;">Precaution for Liquid Gasket2</p> <p>PREPARATION 4</p> <p>PREPARATION 4</p> <p style="padding-left: 20px;">Special Service Tool4</p> <p style="padding-left: 20px;">Commercial Service Tool4</p> <p>FUNCTION DIAGNOSIS 6</p> <p>COOLING SYSTEM 6</p> <p style="padding-left: 20px;">Cooling Circuit6</p> <p style="padding-left: 20px;">Schematic7</p> <p>OVERHEATING CAUSE ANALYSIS 8</p> <p style="padding-left: 20px;">Troubleshooting Chart8</p> <p>ON-VEHICLE MAINTENANCE10</p> <p>ENGINE COOLANT10</p> <p style="padding-left: 20px;">System Inspection10</p> <p style="padding-left: 20px;">Changing Engine Coolant11</p>	<p>ON-VEHICLE REPAIR15</p> <p>RADIATOR15</p> <p style="padding-left: 20px;">Exploded View15</p> <p style="padding-left: 20px;">Removal and Installation15</p> <p style="padding-left: 20px;">Checking Radiator17</p> <p>ENGINE COOLING FAN18</p> <p style="padding-left: 20px;">Exploded View18</p> <p style="padding-left: 20px;">Removal and Installation (Crankshaft driven type)...18</p> <p style="padding-left: 20px;">Removal and Installation (Motor driven type)19</p> <p>WATER PUMP21</p> <p style="padding-left: 20px;">Exploded View21</p> <p style="padding-left: 20px;">Removal and Installation21</p> <p>WATER INLET AND THERMOSTAT ASSEMBLY26</p> <p style="padding-left: 20px;">Exploded View26</p> <p style="padding-left: 20px;">Removal and Installation26</p> <p>WATER OUTLET AND WATER PIPING28</p> <p style="padding-left: 20px;">Exploded View28</p> <p style="padding-left: 20px;">Removal and Installation28</p> <p>SERVICE DATA AND SPECIFICATIONS (SDS)30</p> <p>SERVICE DATA AND SPECIFICATIONS (SDS)30</p> <p style="padding-left: 20px;">Standard and Limit30</p>
---	--

PRECAUTION

PRECAUTIONS

Precaution for Supplemental Restraint System (SRS) "AIR BAG" and "SEAT BELT PRE-TENSIONER"

INFOID:000000004063633

The Supplemental Restraint System such as "AIR BAG" and "SEAT BELT PRE-TENSIONER", used along with a front seat belt, helps to reduce the risk or severity of injury to the driver and front passenger for certain types of collision. This system includes seat belt switch inputs and dual stage front air bag modules. The SRS system uses the seat belt switches to determine the front air bag deployment, and may only deploy one front air bag, depending on the severity of a collision and whether the front occupants are belted or unbelted. Information necessary to service the system safely is included in the SR and SB section of this Service Manual.

WARNING:

- To avoid rendering the SRS inoperative, which could increase the risk of personal injury or death in the event of a collision which would result in air bag inflation, all maintenance must be performed by an authorized NISSAN/INFINITI dealer.
- Improper maintenance, including incorrect removal and installation of the SRS, can lead to personal injury caused by unintentional activation of the system. For removal of Spiral Cable and Air Bag Module, see the SR section.
- Do not use electrical test equipment on any circuit related to the SRS unless instructed to in this Service Manual. SRS wiring harnesses can be identified by yellow and/or orange harnesses or harness connectors.

Precaution for Liquid Gasket

INFOID:000000004063634

REMOVAL OF LIQUID GASKET SEALING

- After removing nuts and bolts, separate the mating surface, using Tool and remove old liquid gasket sealing.

Tool number : KV10111100 (J-37228)

CAUTION:

Be careful not to damage the mating surfaces.

- Tap (1) Tool to insert it, and then slide (2) it by tapping on the side as shown.
- In areas where Tool is difficult to use, use plastic hammer to lightly tap the parts, to remove it.

CAUTION:

If for some unavoidable reason suitable tool such as screwdriver is used, be careful not to damage the mating surfaces.

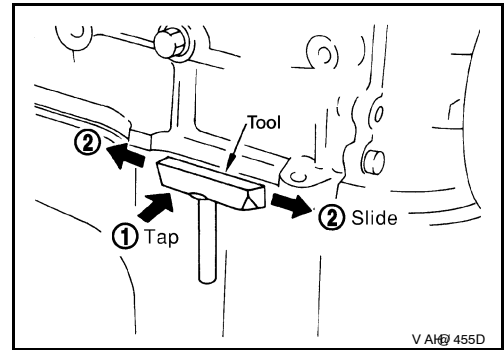

LIQUID GASKET APPLICATION PROCEDURE

1. Remove the old liquid gasket adhering to the gasket application surface and the mating surface using suitable tool.
 - Remove the liquid gasket completely from the groove of the liquid gasket application surface, bolts, and bolt holes.
2. Thoroughly clean the mating surfaces and remove adhering moisture, grease and foreign material.

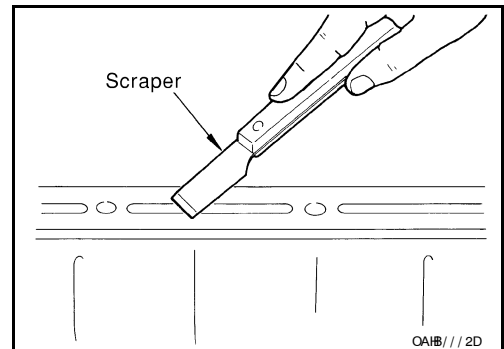

PRECAUTIONS

[VQ40DE]

< PRECAUTION >

3. Attach the liquid gasket tube to the Tool.

Tool number : WS39930000 (—)

Use Genuine RTV Silicone Sealant or equivalent. Refer to [GI-14, "Recommended Chemical Products and Sealants"](#).

4. Apply the liquid gasket without breaks to the specified location with the specified dimensions.

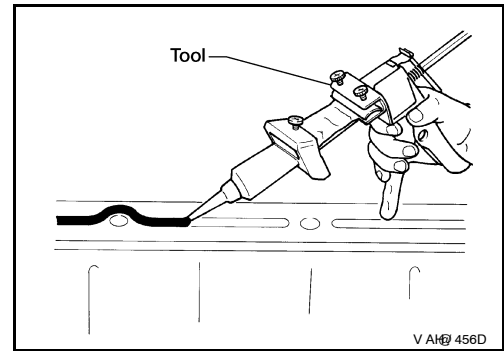

- If there is a groove for the liquid gasket application, apply the liquid gasket to the groove.
- As for the bolt holes, normally apply the liquid gasket inside the holes. If specified in the procedure, it should also be applied outside the holes.
- Within five minutes of liquid gasket application, install the mating component.
- If the liquid gasket protrudes, wipe it off immediately.
- Do not retighten after the installation.
- Wait 30 minutes or more after installation before refilling the engine with engine oil and engine coolant.

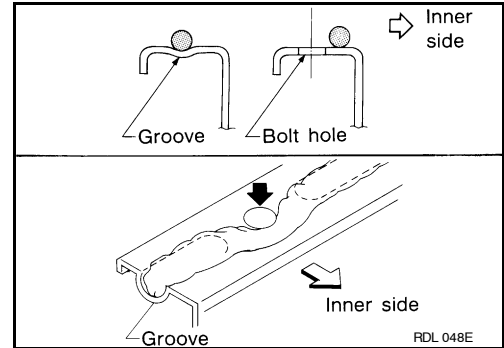

CAUTION:

If there are specific instructions in this manual, observe them.

A
CO
C
D
E
F
G
H
I
J
K
L
M
N
O
P

PREPARATION

< PREPARATION >

[VQ40DE]

PREPARATION

PREPARATION

Special Service Tool

INFOID:000000004063635

The actual shapes of Kent-Moore tools may differ from those of special service tools illustrated here.

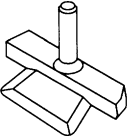
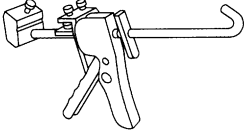
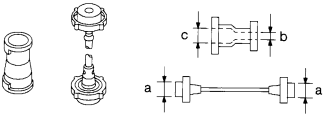
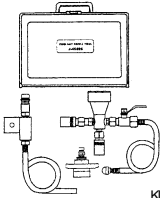
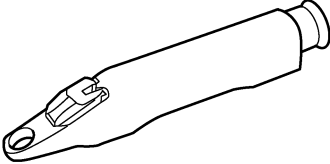
Tool number (Kent-Moore No.) Tool name	Description
KV10111100 (J-37228) Seal cutter  MS/35	Removing chain tensioner cover and water pump cover
WS39930000 (—) Tube presser  R,MS/41	Pressing the tube of liquid gasket
EG17650301 (J-33984-A) Radiator cap tester adapter  R,MS453	Adapting radiator cap tester to radiator cap and radiator filler neck a: 28 (1.10) dia. b: 31.4 (1.236) dia. c: 41.3 (1.626) dia. Unit: mm (in)
KV991J0070 (J-45695) Coolant refill tool  KL @ 42	Filling cooling system
KV991J0010 (J-23688) Engine coolant refractometer  V A1@ 428D	Checking concentration of ethylene glycol in engine coolant

Commercial Service Tool

INFOID:000000004063636

PREPARATION

< PREPARATION >

[VQ40DE]

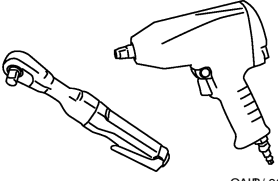
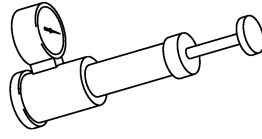
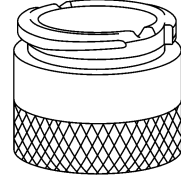
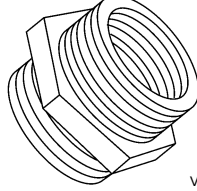
Tool name	Description
<p>Power tool</p>  <p style="text-align: right; font-size: small;">OAHB/08/D</p>	<p>Loosening bolts and nuts</p>
<p>Radiator cap tester</p>  <p style="text-align: right; font-size: small;">OAHB0871D</p>	<p>Checking radiator and radiator cap</p>
<p>Coolant system tester adapter</p>  <p style="text-align: right; font-size: small;">V AH@3/7D</p>	<p>Adapting radiator cap tester to reservoir filler neck</p>
<p>Coolant system tester adapter</p>  <p style="text-align: right; font-size: small;">V AH@3/8D</p>	<p>Adapting radiator cap tester to reservoir cap</p>

A

CO

C

D

E

F

G

H

I

J

K

L

M

N

O

P

FUNCTION DIAGNOSIS

COOLING SYSTEM

Cooling Circuit

INFOID:000000004063637

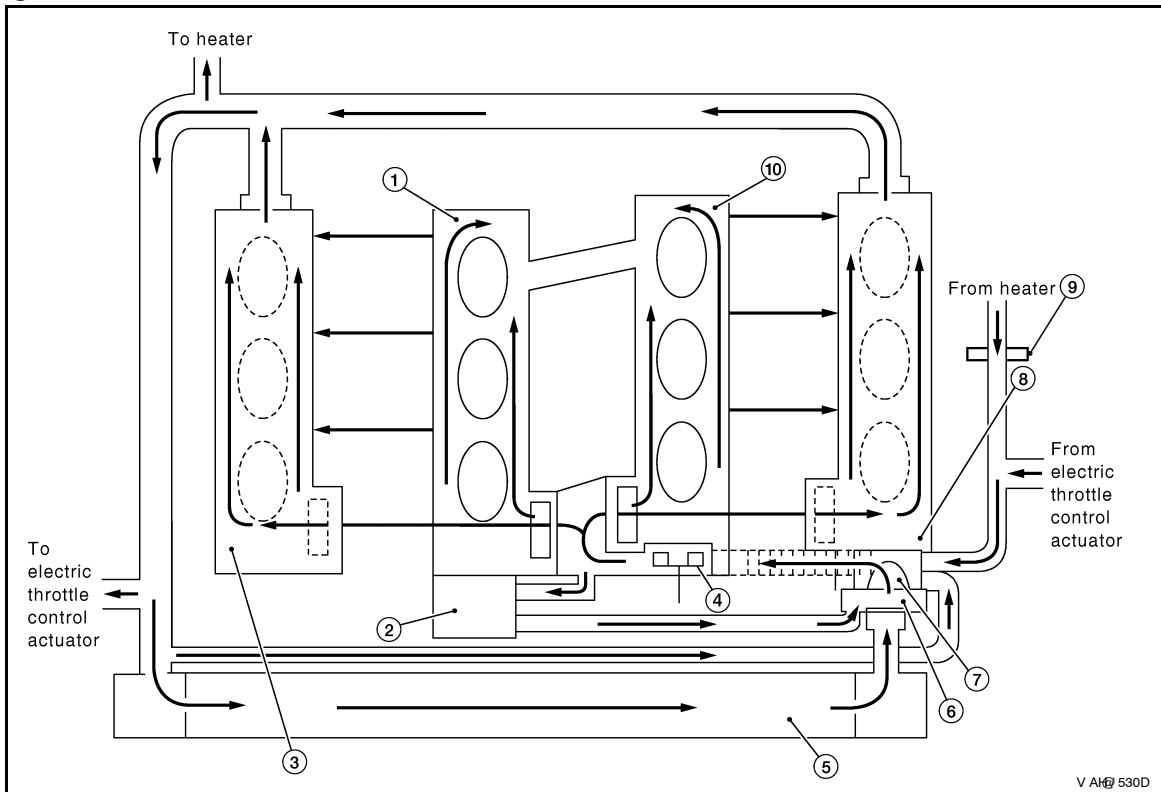

- | | | |
|-------------------------|-----------------------|-----------------------|
| 1. Cylinder block (RH) | 2. Oil cooler | 3. Cylinder head (RH) |
| 4. Water pump | 5. Radiator | 6. Water inlet |
| 7. Thermostat | 8. Cylinder head (LH) | 9. Heater pump |
| 10. Cylinder block (LH) | | |

COOLING SYSTEM

< FUNCTION DIAGNOSIS >

[VQ40DE]

Schematic

INFOID:000000004063638

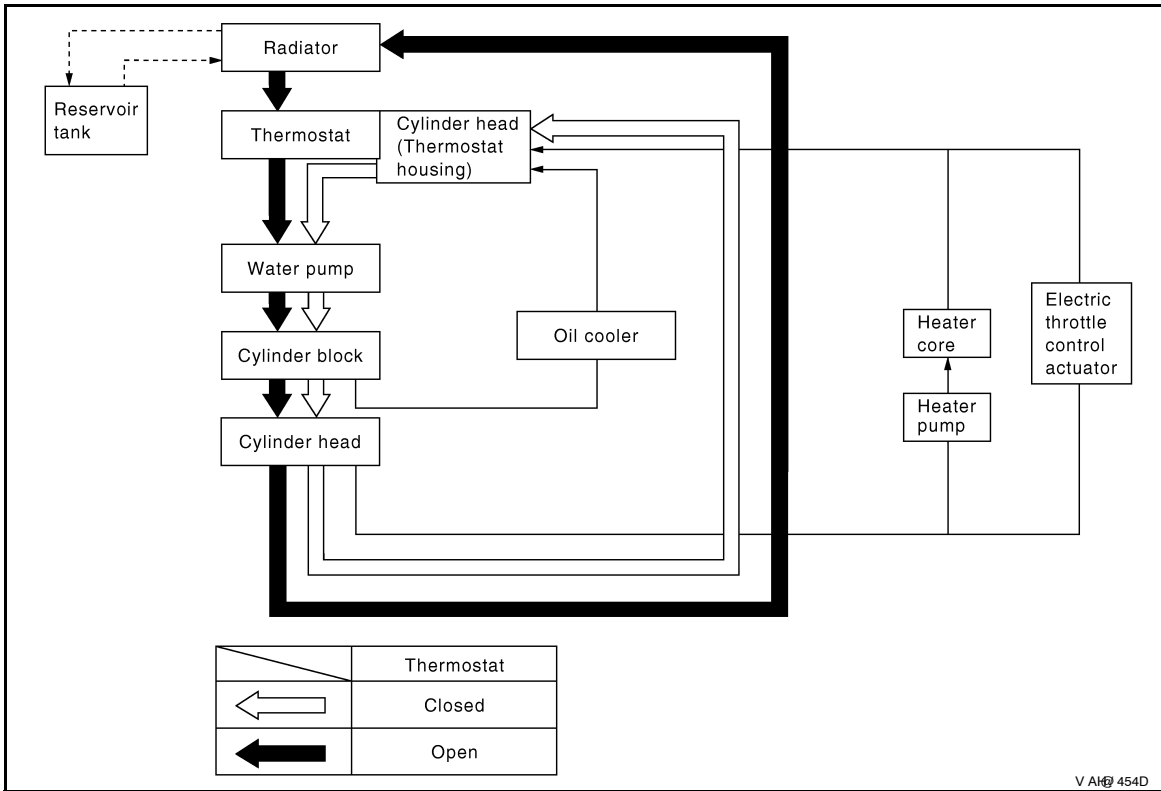

A

CO

C

D

E

F

G

H

I

J

K

L

M

N

O

P

OVERHEATING CAUSE ANALYSIS

< FUNCTION DIAGNOSIS >

[VQ40DE]

OVERHEATING CAUSE ANALYSIS

Troubleshooting Chart

INFOID:000000004063639

		Symptom	Check items		
Cooling system parts malfunction	Poor heat transfer	Water pump malfunction	Worn or loose drive belt	—	
		Thermostat stuck closed	—		
		Damaged fins	Dust contamination or paper clogging		
			Physical damage		
		Clogged radiator cooling tube	Excess foreign material (rust, dirt, sand, etc.)		
	Reduced air flow	Cooling fan does not operate	Fan assembly	—	
		High resistance to fan rotation			
		Damaged fan blades			
		Damaged radiator shroud	—	—	
		Improper engine coolant mixture ratio	—	—	
		Poor engine coolant quality	—	Engine coolant viscosity	—
	Insufficient engine coolant	Engine coolant leaks	Cooling hose	Loose clamp	
				Cracked hose	
			Heater pump	Physical damage	
			Water pump	Poor sealing	
Radiator cap			Loose		
			Poor sealing		
Radiator		O-ring for damage, deterioration or improper fitting			
		Cracked radiator tank			
	Cracked radiator core				
	Reservoir tank	Cracked reservoir tank			
Overflowing reservoir tank	Exhaust gas leaks into cooling system	Cylinder head deterioration			
		Cylinder head gasket deterioration			

OVERHEATING CAUSE ANALYSIS

< FUNCTION DIAGNOSIS >

[VQ40DE]

	Symptom		Check items			
Except cooling system parts malfunction	—	Overload on engine	Abusive driving	High engine rpm under no load	A	
				Driving in low gear for extended time	CO	
				Driving at extremely high speed		
				Powertrain system malfunction		C
				Installed improper size wheels and tires	—	D
				Dragging brakes		
			Improper ignition timing		E	
	Blocked or restricted air flow	Blocked bumper	—			
		Blocked radiator grille	Installed car brassiere			
			Mud contamination or paper clogging	—	F	
		Blocked radiator	—			
		Blocked condenser	Blocked air flow			G
Installed large fog lamp						

H
I
J
K
L
M
N
O
P

ON-VEHICLE MAINTENANCE

ENGINE COOLANT

System Inspection

INFOID:000000004063640

WARNING:

- Never remove the radiator/reservoir cap when the engine is hot. Serious burns could occur from high pressure fluid escaping from the radiator or reservoir.
- Wrap a thick cloth around the cap. Slowly push down and turn it a quarter turn to allow built-up pressure to escape. Carefully remove the cap by pushing down and turning it all the way.

CHECKING COOLING SYSTEM HOSES

Check hoses for the following:

- Improper attachment
- Leaks
- Cracks
- Damage
- Loose connections
- Chafing
- Deterioration

CHECKING RESERVOIR LEVEL

- Check if the engine coolant reservoir tank level is within MIN to MAX when the engine is cool.
- Adjust engine coolant level as necessary.

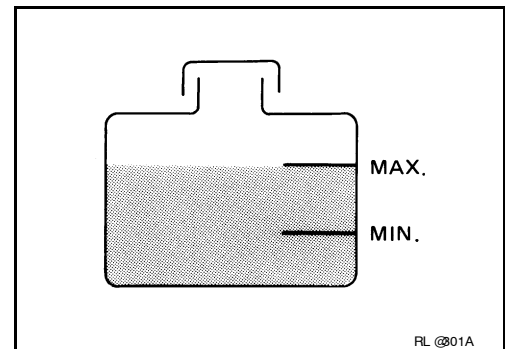

CHECKING COOLING SYSTEM FOR LEAKS

WARNING:

Never remove the radiator/reservoir cap when the engine is hot. Serious burns could occur from high pressure coolant escaping from the radiator or reservoir.

To check for leakage, apply pressure to the cooling system using Tool.

Tool number : EG17650301 (J-33984-A)

Testing pressure : 137 kPa (1.4 kg/cm², 20 psi)

CAUTION:

Higher pressure than specified may cause radiator damage.

NOTE:

In case that engine coolant decreases, replenish cooling system with engine coolant.

If any concerns are found, repair or replace damaged parts.

CHECKING RESERVOIR CAP

1. Inspect the reservoir cap.
 - Replace the cap if the metal plunger cannot be seen around the edge of the black rubber gasket.
 - Replace the cap if deposits of waxy residue or other foreign material are on the black rubber gasket or the metal retainer.

NOTE:

Thoroughly wipe out the reservoir filler neck to remove any waxy residue or foreign material.

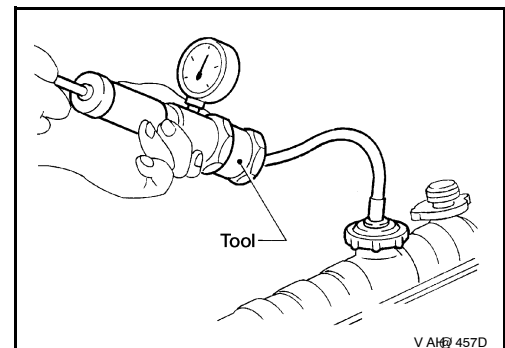

ENGINE COOLANT

[VQ40DE]

< ON-VEHICLE MAINTENANCE >

2. Pull the negative-pressure valve to open it and check that it closes completely when released.
 - Check that there is no dirt or damage on the valve seat of the reservoir cap negative-pressure valve.
 - Check that there are no abnormalities in the opening and closing conditions of the negative-pressure valve.

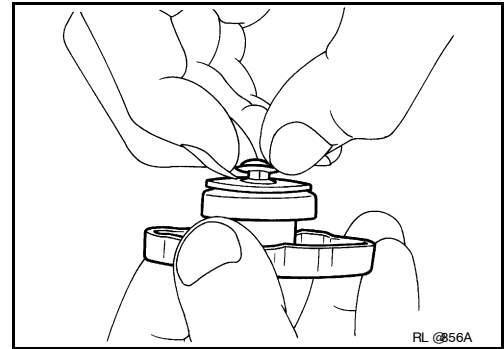

3. Check reservoir cap relief pressure using suitable tool and Tool.

Tool number : EG17650301 (J-33984-A)

Standard: 78 – 98 kPa (0.8 – 1.0 kg/cm², 11 – 14 psi)

Limit: 59 kPa (0.6 kg/cm², 9 psi)

NOTE:

- Apply engine coolant to the cap seal surface.
- Replace the reservoir cap if there is any damage in the negative-pressure valve, or if the open-valve pressure is outside of the limit.

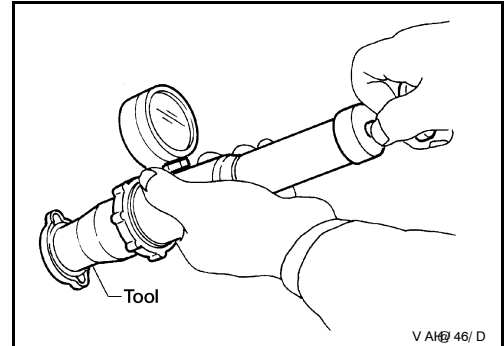

CHECKING RADIATOR CAP

Inspect the radiator cap.

NOTE:

Thoroughly wipe out the radiator filler neck to remove any waxy residue or foreign material.

- Replace the cap if the metal plunger cannot be seen around the edge of the black rubber gasket.
- Replace the cap if deposits of waxy residue or other foreign material are on the black rubber gasket or the metal retainer.

CHECKING RADIATOR

Check radiator for mud or clogging. If necessary, clean radiator as follows.

CAUTION:

- **Be careful not to bend or damage the radiator fins.**
- **When radiator is cleaned without removal, remove all surrounding parts such as cooling fan shroud and horns. Then tape the harness and electrical connectors to prevent water from entering.**

1. Apply water by hose to the back side of the radiator core, with the hose pointed vertically downward.
2. Apply water again to all radiator core surfaces once per minute.
3. Stop washing if any stains no longer flow out from the radiator.
4. Blow air into the back side of radiator core, with the air hose pointed vertically downward.
 - Use compressed air lower than 490 kPa (5 kg/cm², 71 psi) and keep distance more than 30 cm (11.8 in).
5. Blow air again into all the radiator core surfaces once per minute until no water sprays out.
6. Check for leaks.

Changing Engine Coolant

INFOID:000000004063641

WARNING:

- **To avoid being scalded, never change the coolant when the engine is hot.**
- **Wrap a thick cloth around the cap to carefully remove the cap. First, turn the cap a quarter of a turn to release any built-up pressure, then push down and turn the cap all the way to remove it.**

DRAINING ENGINE COOLANT

1. Turn ignition switch ON and set temperature control lever all the way to HOT position or the highest temperature position. Wait 10 seconds and turn ignition switch OFF.
2. Remove the engine front undercover using power tool.

ENGINE COOLANT

< ON-VEHICLE MAINTENANCE >

[VQ40DE]

3. Open the radiator drain plug at the bottom of the radiator, and remove the reservoir cap. This is the only step required when partially draining the cooling system (radiator only).

CAUTION:

Do not to allow the coolant to contact the drive belts.

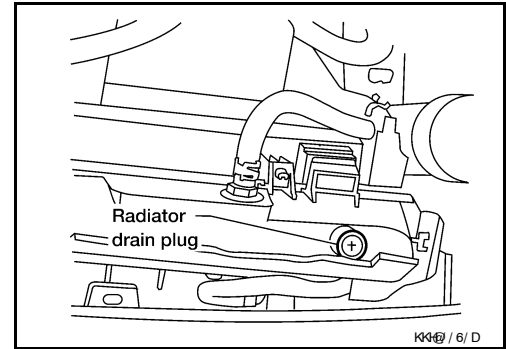

4. When draining all of the coolant in the system for engine removal or repair, it is necessary to drain the cylinder block. Remove the cylinder block drain plugs (A), (B), (C), (D) and block heater if equipped, to drain the cylinder block as shown.

NOTE:

For Canada, the (D) cylinder block drain plug as shown, is not a cylinder block drain plug but a block heater.

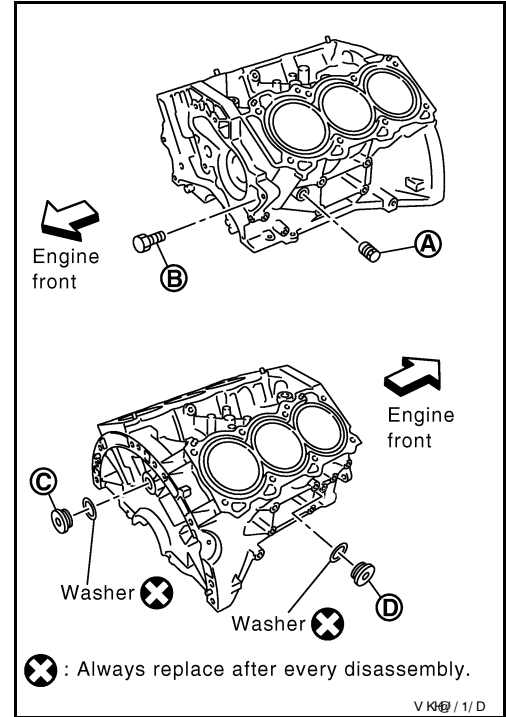

5. Remove the reservoir tank to drain the engine coolant, then clean the reservoir tank before installing it.
6. Check the drained coolant for contaminants such as rust, corrosion or discoloration. If the coolant is contaminated, flush the engine cooling system. Follow the "Flushing Cooling System" procedure.

REFILLING ENGINE COOLANT

ENGINE COOLANT

[VQ40DE]

< ON-VEHICLE MAINTENANCE >

1. Close the radiator drain plug. Install the reservoir tank, cylinder block drain plugs (A), (B), (C), (D) and block heater if equipped, if removed for a total system drain or for engine removal or repair.
 - The radiator must be completely empty of coolant and water.
 - Apply sealant to the threads of the cylinder block drain plugs (A), (B), (C), (D). Use Genuine High Performance Thread Sealant or equivalent. Refer to [GI-14, "Recommended Chemical Products and Sealants"](#).
 - Tighten each plug to the specified torque. Refer to [EM-107, "Disassembly and Assembly"](#).

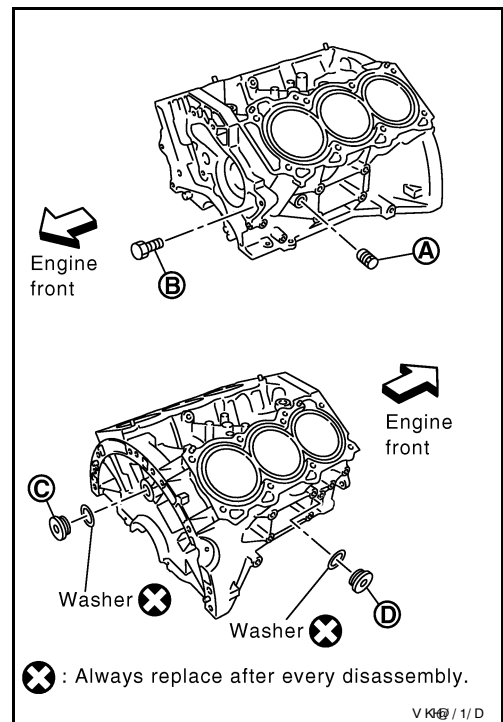

2. Set the vehicle heater controls to the full HOT and heater ON position. Turn the vehicle ignition ON with the engine OFF as necessary to activate the heater mode.
3. Remove the vented reservoir cap and replace it with a non-vented reservoir cap before filling the cooling system.
4. Install the Tool by installing the radiator cap adapter onto the radiator neck opening. Then attach the gauge body assembly with the refill tube and the venturi assembly to the radiator cap adapter.

Tool number : KV991J0070 (J-45695)

5. Insert the refill hose into the coolant mixture container that is placed at floor level. Make sure the ball valve is in the closed position.
 - Use recommended coolant or equivalent. Refer to [MA-11, "Fluids and Lubricants"](#).

Cooling system capacity (with reservoir) : Refer to [MA-11, "Fluids and Lubricants"](#).

6. Install an air hose to the venturi assembly, the air pressure must be within specification.

Compressed air supply pressure : 5.7 - 8.5 kPa (5.6 - 8.4 kg/cm², 80 - 120 psi)

CAUTION:

The compressed air supply must be equipped with an air dryer.

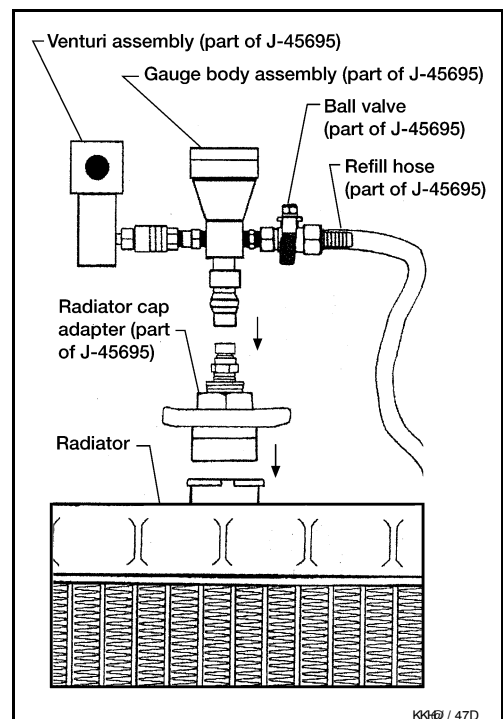

7. The vacuum gauge will begin to rise and there will be an audible hissing noise. During this process open the ball valve on the refill hose slightly. Coolant will be visible rising in the refill hose. Once the refill hose is full of coolant, close the ball valve. This will purge any air trapped in the refill hose.

ENGINE COOLANT

< ON-VEHICLE MAINTENANCE >

[VQ40DE]

8. Continue to draw the vacuum until the gauge reaches 28 inches of vacuum. The gauge may not reach 28 inches in high altitude locations, use the vacuum specifications based on the altitude above sea level.

Altitude above sea level	Vacuum gauge reading
0 - 100 m (328 ft)	: 28 inches of vacuum
300 m (984 ft)	: 27 inches of vacuum
500 m (1,641 ft)	: 26 inches of vacuum
1,000 m (3,281 ft)	: 24 - 25 inches of vacuum

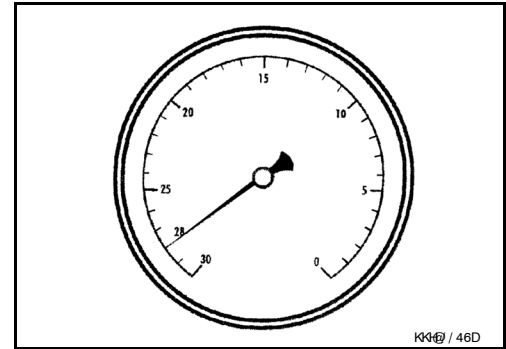

9. When the vacuum gauge has reached the specified amount, disconnect the air hose and wait 20 seconds to see if the system loses any vacuum. If the vacuum level drops, perform any necessary repairs to the system and repeat steps 6 - 8 to bring the vacuum to the specified amount. Recheck for any leaks.
10. Place the coolant container (with the refill hose inserted) at the same level as the top of the radiator. Then open the ball valve on the refill hose so the coolant will be drawn up to fill the cooling system. The cooling system is full when the vacuum gauge reads zero.

CAUTION:

Do not allow the coolant container to get too low when filling, to avoid air from being drawn into the cooling system.

11. Remove the Tool from the radiator neck opening and install the radiator cap.
12. Remove the non-vented reservoir cap.
13. Fill the cooling system reservoir tank to the specified level. Run the engine to warm up the cooling system and top up the system as necessary before installing the vented reservoir cap.

FLUSHING COOLING SYSTEM

1. Drain the water from the engine cooling system. Refer to [CO-11, "Changing Engine Coolant"](#).
2. Fill the radiator and the reservoir tank (to the "MAX" line), with water. Reinstall the radiator cap and leave the vented reservoir cap off.
3. Run the engine until it reaches normal operating temperature.
4. Press the engine accelerator two or three times under no-load.
5. Stop the engine and wait until it cools down.
6. Drain the water from the engine cooling system. Refer to [CO-11, "Changing Engine Coolant"](#).
7. Repeat steps 2 through 6 until clear water begins to drain from the radiator.

RADIATOR

< ON-VEHICLE REPAIR >

[VQ40DE]

ON-VEHICLE REPAIR

RADIATOR

Exploded View

INFOID:000000004063642

SEC. 214

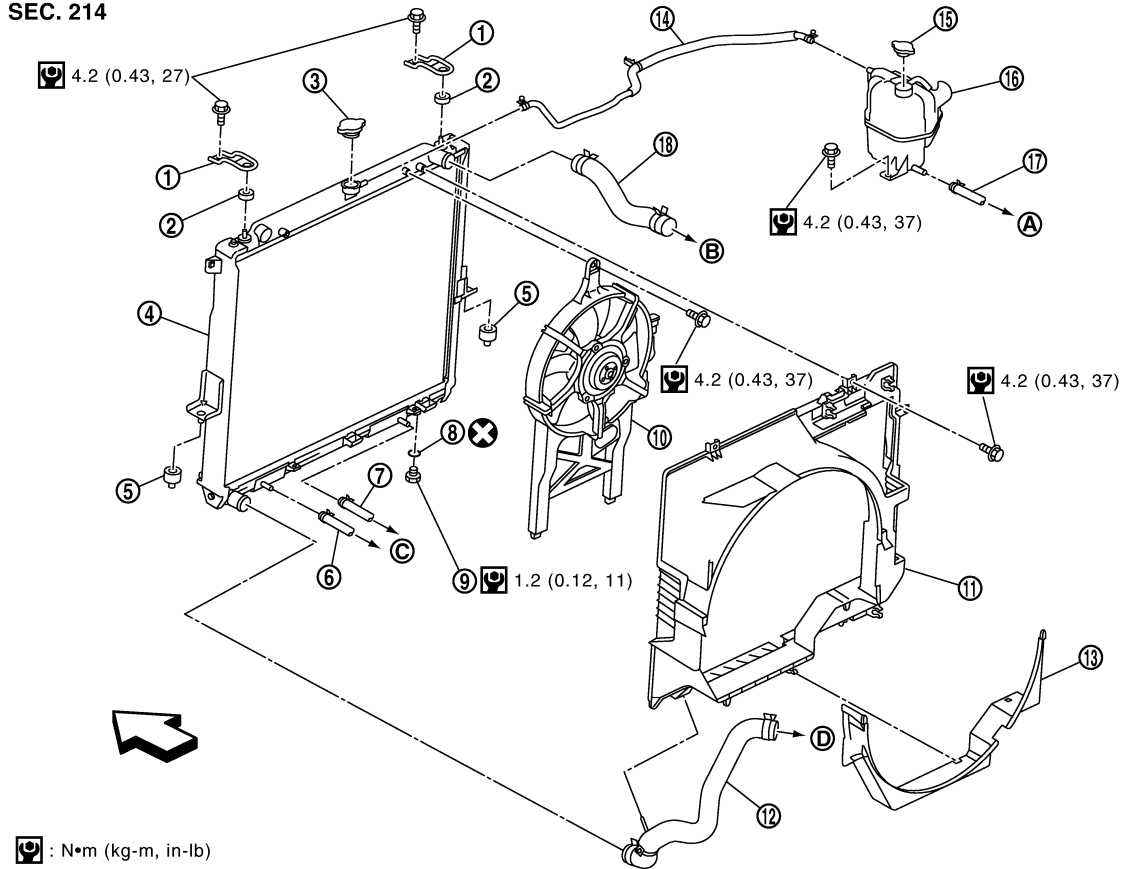

: N•m (kg-m, in-lb)

QAI#2750D

- | | | |
|---|-----------------------------|---------------------------|
| 1. Radiator mounting bracket | 2. Mounting rubber (upper) | 3. Radiator cap |
| 4. Radiator | 5. Mounting rubber (lower) | 6. A/T fluid cooler hose |
| 7. A/T fluid cooler hose (if equipped) | 8. O-ring | 9. Drain plug |
| 10. Cooling fan assembly | 11. Radiator shroud (upper) | 12. Radiator hose (lower) |
| 13. Radiator shroud (lower) | 14. Reservoir tank hose | 15. Reservoir tank cap |
| 16. Reservoir tank | 17. Water hose | 18. Radiator hose (upper) |
| A. To heater return tube | B. To water pipe | C. To A/T cooler tube |
| D. To water inlet and thermostat assembly | ← Vehicle front | |

Removal and Installation

INFOID:000000004063643

WARNING:

Do not remove radiator cap when engine is hot. Serious burns could occur from high-pressure engine coolant escaping from radiator. Wrap a thick cloth around the cap. Slowly turn it a quarter of a turn to release built-up pressure. Carefully remove radiator cap by turning it all the way.

REMOVAL

1. Remove air dam using power tool.
2. Remove engine undercover using power tool.
3. Drain engine coolant from radiator. Refer to [CO-10](#).

CAUTION:

- Perform this step when engine is cold.

RADIATOR

< ON-VEHICLE REPAIR >

[VQ40DE]

- Do not spill engine coolant on drive belts.

4. Remove air duct and air cleaner case assembly. Refer to [EM-24, "Removal and Installation"](#).
5. Remove reservoir tank hose.
6. Remove radiator hoses (upper and lower).
CAUTION:
Be careful not to allow engine coolant to contact drive belts.
7. Disconnect A/T fluid cooler hoses, if equipped.
 - Install blind plug to avoid leakage of A/T fluid.
8. Remove radiator shroud (lower).
9. Remove radiator shroud (upper).
10. Remove radiator cooling fan assembly. Refer to [CO-18](#).
11. Remove the upper radiator mounting bracket bolts.

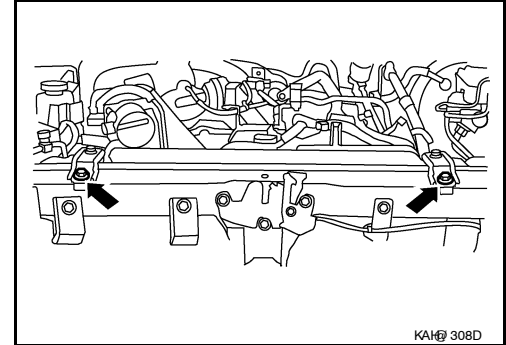

12. Remove the two A/C condenser bolts.

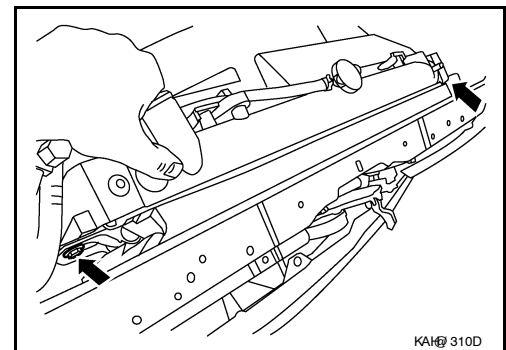

13. Remove radiator as follows:

CAUTION:

Do not damage or scratch A/C condenser and radiator core when removing.

- a. With lifting and pulling radiator in a rear direction, disassemble mounting rubber (lower) from radiator core support center.

CAUTION:

Because A/C condenser is attached to the front-lower portion of radiator, moving it in the rear direction should be at a minimum.

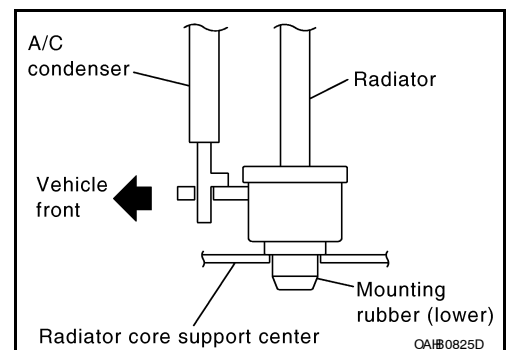

RADIATOR

< ON-VEHICLE REPAIR >

[VQ40DE]

- b. Lift A/C condenser up and remove radiator after disengaging the fitting at front-bottom surface.

CAUTION:

Lifting A/C condenser should be minimum to prevent a load to A/C piping.

- c. After removing radiator, put A/C condenser on radiator core support center to prevent a load to A/C piping, and temporarily fix it with rope or similar means.

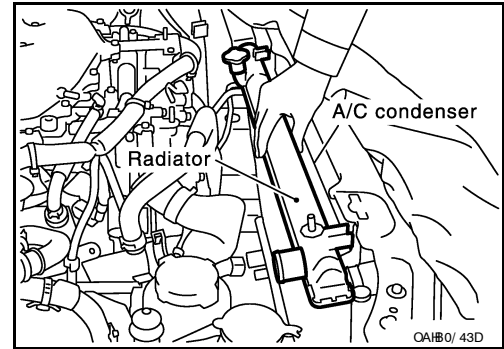

INSTALLATION

Installation is in the reverse order of removal.

INSPECTION AFTER INSTALLATION

- Check for leaks of engine coolant. Refer to [CO-10. "System Inspection"](#).
- Start and warm up engine. Visually check there are no leaks of engine coolant and A/T fluid.

Checking Radiator

INFOID:000000004063644

Check radiator for mud or clogging. If necessary, clean radiator as follows.

CAUTION:

- **Be careful not to bend or damage the radiator fins.**
 - **When radiator is cleaned without removal, remove all surrounding parts such as cooling fan, radiator shroud and horns. Then tape the harness and electrical connectors to prevent water from entering.**
1. Apply water by hose to the back side of the radiator core vertically downward.
 2. Apply water again to all radiator core surfaces.
 3. Stop washing when dirt and debris no longer flow out from the radiator.
 4. Blow air into the back side of radiator core vertically downward.
 - Use compressed air lower than 490 kPa (5 kg/cm², 71 psi) and keep distance more than 30 cm (11.8 in).
 5. Blow air again into all the radiator core surfaces until no water sprays out.
 6. Check for leaks.

ENGINE COOLING FAN

< ON-VEHICLE REPAIR >

[VQ40DE]

ENGINE COOLING FAN

Exploded View

INFOID:000000004063645

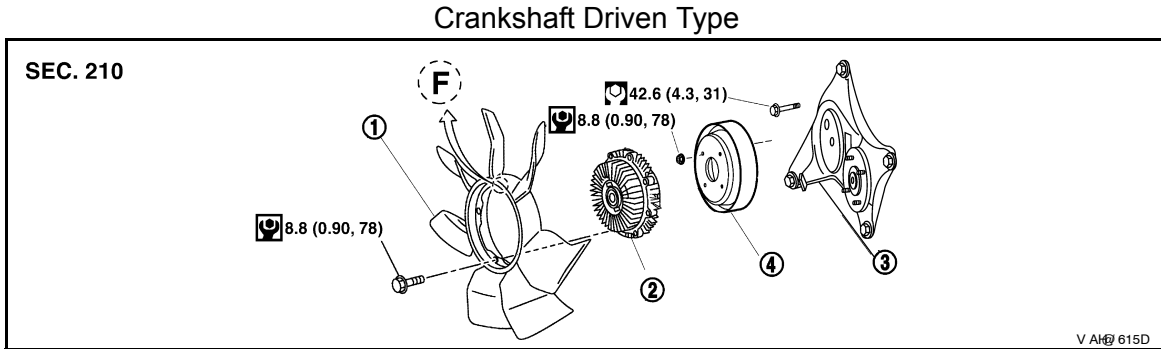

1. Cooling fan
2. Fan coupling
3. Fan bracket
4. Cooling fan pulley

Removal and Installation (Crankshaft driven type)

INFOID:000000004063646

REMOVAL

1. Remove air dam using power tool.
2. Remove engine front undercover using power tool.
3. Partially drain engine coolant from radiator. Refer to [CO-10](#).
CAUTION:
 - Perform this step when engine is cold.
 - Do not spill engine coolant on drive belts.
4. Remove air duct. Refer to [EM-24, "Removal and Installation"](#).
5. Remove reservoir tank hose from shroud.
6. Removal radiator hose (upper) from radiator.
CAUTION:
Do not spill engine coolant on drive belts.
7. Release the radiator shroud (lower) (2) from the radiator shroud (upper) (1) and position aside.
 - Release the tabs, pull radiator shroud (lower) (2) rearwards and down.

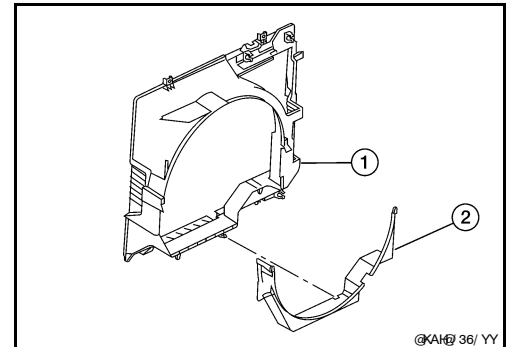

8. Remove the radiator shroud (upper) bolts and remove the radiator shroud (upper). Refer to [CO-15, "Exploded View"](#).
9. Remove the drive belt. Refer to [EM-12, "Removal and Installation"](#).
10. Remove the engine cooling fan.

INSPECTION AFTER REMOVAL

Fan Coupling

ENGINE COOLING FAN

< ON-VEHICLE REPAIR >

[VQ40DE]

Inspect fan coupling for oil leakage and bimetal conditions.

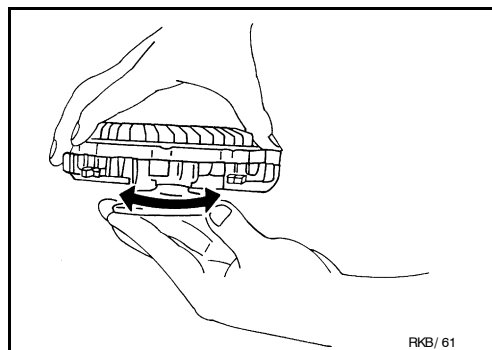

Fan Bracket

- Visually check that there is no significant looseness in the fan bracket shaft, and that it turns smoothly by hand.
- If there are any unusual concerns, replace the fan bracket assembly.

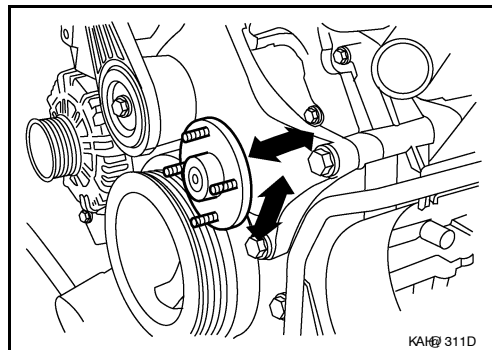

INSTALLATION

Installation is in the reverse order of removal.

- Install cooling fan with its front mark "F" facing front of engine. Refer to [CO-18, "Removal and Installation \(Crankshaft driven type\)"](#).

INSPECTION AFTER INSTALLATION

- Check for leaks of the engine coolant. Refer to [CO-10, "System Inspection"](#).
- Start and warm up the engine. Visually make sure that there are no leaks of the engine coolant.

Removal and Installation (Motor driven type)

INFOID:000000004063647

REMOVAL

1. Remove the air dam using power tool.
2. Remove the engine front undercover using power tool.
3. Partially drain engine coolant from radiator. Refer to [CO-11, "Changing Engine Coolant"](#).

CAUTION:

- Perform this step when engine is cold.
 - Do not spill engine coolant on drive belts.
4. Release the radiator shroud (lower) (2) from the radiator shroud (upper) (1) and position aside.
 - Release the tabs, pull radiator shroud (lower) (2) rearwards and down.

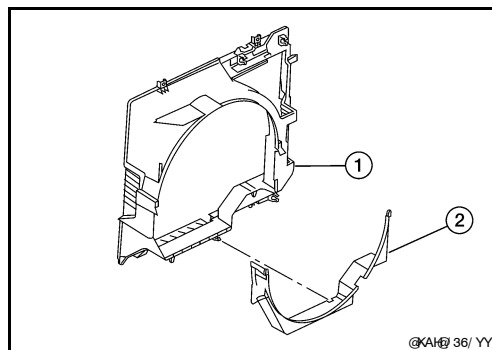

5. Remove air duct. Refer to [EM-24, "Removal and Installation"](#).
6. Remove reservoir tank hose from radiator shroud (upper).
7. Remove the radiator shroud (upper) bolts and remove the radiator shroud (upper). Refer to [CO-15, "Exploded View"](#).

ENGINE COOLING FAN

[VQ40DE]

< ON-VEHICLE REPAIR >

8. Disconnect harness connector from fan motor.
9. Remove the bolt and remove the fan grille and motor assembly.

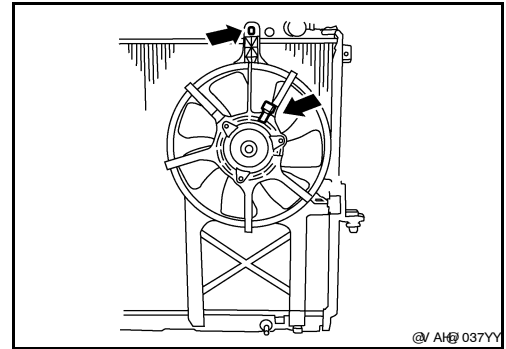

INSTALLATION

Installation is in the reverse order of removal.

- Cooling fan is controlled by ECM. For details, refer to [EC-307. "Diagnosis Procedure"](#).

WATER PUMP

< ON-VEHICLE REPAIR >

[VQ40DE]

WATER PUMP

Exploded View

INFOID:000000004063648

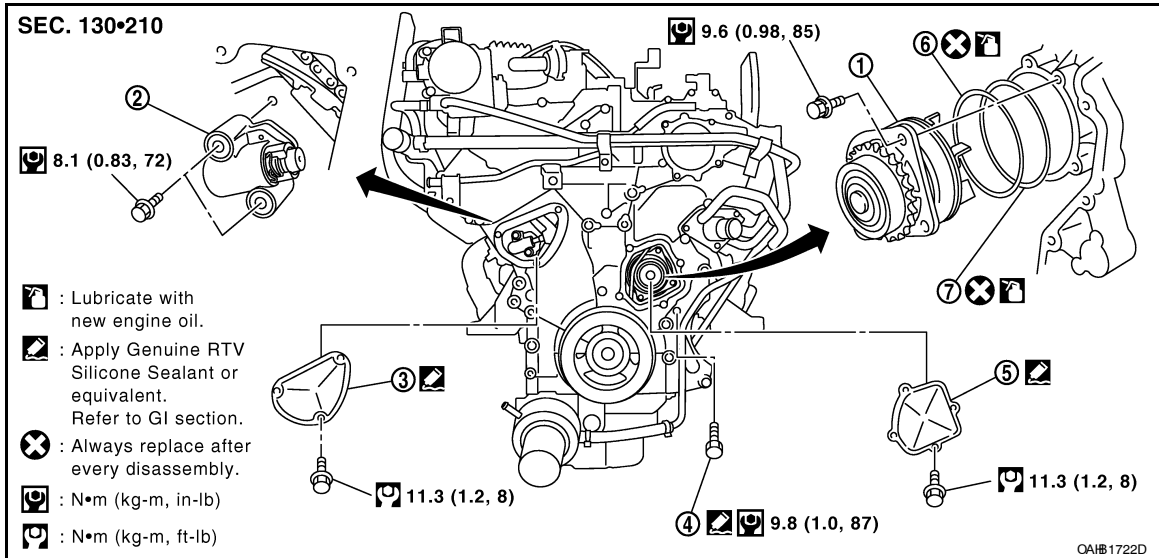

- | | | |
|-----------------------------|-------------------------------------|--------------------------|
| 1. Water pump | 2. Timing chain tensioner (primary) | 3. Chain tensioner cover |
| 4. Water drain plug (front) | 5. Water pump cover | 6. O-ring |
| 7. O-ring | | |

Removal and Installation

INFOID:000000004063649

CAUTION:

- When removing water pump assembly, be careful not to get engine coolant on timing chain and drive belt.
- Water pump cannot be disassembled and should be replaced as a unit.
- After installing water pump, connect hose and clamp securely, then check for leaks.

REMOVAL

1. Remove air dam using power tool.
2. Remove engine front undercover using power tool.
3. Remove air duct and resonator assembly. Refer to [EM-24, "Removal and Installation"](#).
4. Remove drive belt. Refer to [EM-12, "Removal and Installation"](#).
5. Drain engine coolant. Refer to [CO-10](#).
CAUTION:
 - Perform this step when engine is cold.
 - Do not spill engine coolant on timing chain and drive belt.
6. Remove radiator hose (upper).
7. Remove cooling fan (Crankshaft driven type). Refer to [CO-18, "Removal and Installation \(Crankshaft driven type\)"](#).

WATER PUMP

[VQ40DE]

< ON-VEHICLE REPAIR >

8. Remove chain tensioner cover and water pump cover from front timing chain case, using Tool.

Tool number : KV10111100 (J-37228)

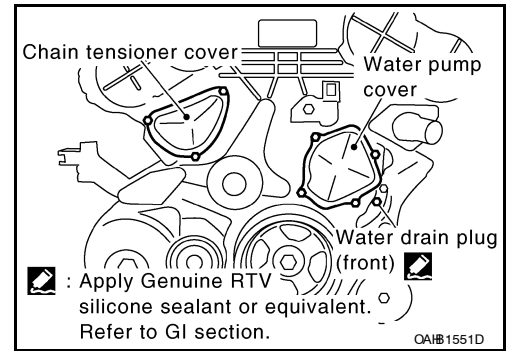

9. Remove timing chain tensioner (primary) as follows:
- Loosen clip of timing chain tensioner (primary), and release plunger stopper (1).
 - Insert plunger into tensioner body by pressing slack guide (2).
 - Keep slack guide pressed and hold plunger in by pushing stopper pin through the tensioner body hole and plunger groove (3).

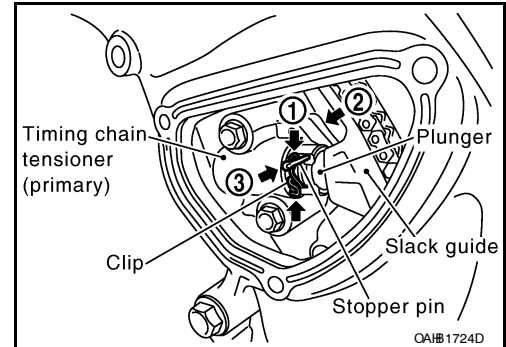

- d. Turn crankshaft pulley clockwise so that timing chain on the timing chain tensioner (primary) side is loose.

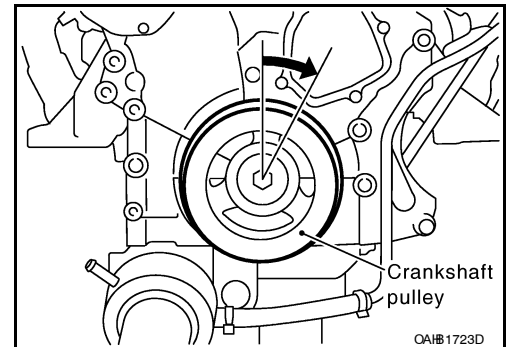

- e. Remove bolts and remove timing chain tensioner (primary).
CAUTION:
Be careful not to drop bolts inside timing chain case.

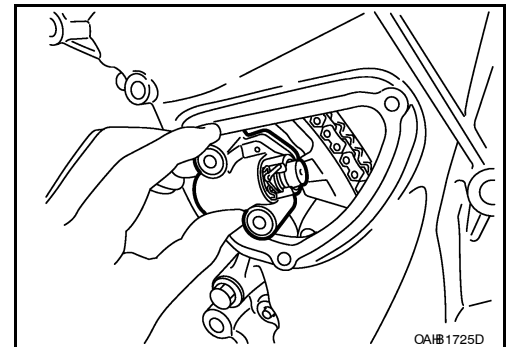

10. Remove water pump as follows:

WATER PUMP

[VQ40DE]

< ON-VEHICLE REPAIR >

- a. Remove three water pump bolts. Secure a gap between water pump gear and timing chain, by turning crankshaft pulley counterclockwise until timing chain looseness on water pump sprocket becomes maximum.

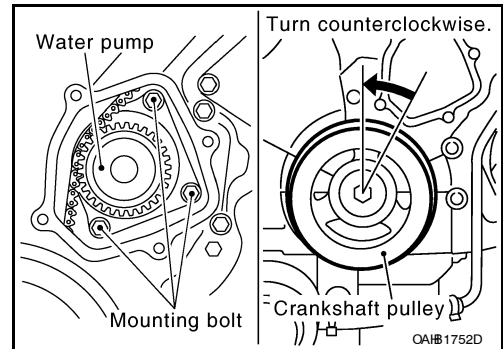

- b. Screw M8 bolts [pitch: 1.25 mm (0.049 in) length: approx. 50 mm (1.97 in)] into water pumps upper and lower bolt holes until they reach timing chain case. Then, alternately tighten each bolt for a half turn, and pull out water pump.

CAUTION:

- Pull straight out while preventing vane from contacting socket in installation area.
- Remove water pump without causing sprocket to contact timing chain.
- Do not spill engine coolant into timing chain case.

- c. Remove M8 bolts and O-rings from water pump.

CAUTION:

Do not disassemble water pump.

NOTE:

Do not reuse O-rings.

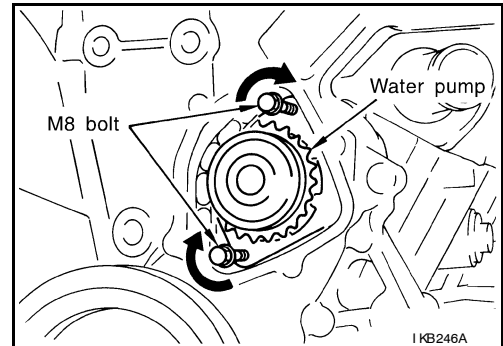

INSPECTION AFTER REMOVAL

- Check for badly rusted or corroded water pump body assembly.
- Check for rough operation due to excessive end play.
- Replace water pump, if necessary.

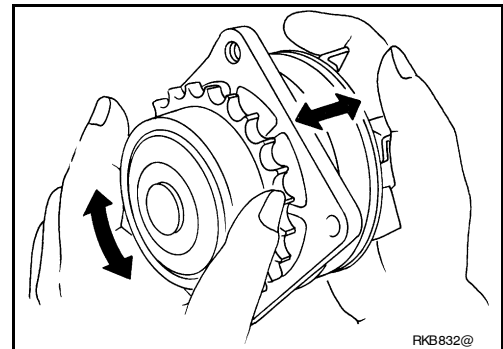

INSTALLATION

1. Install new O-rings to water pump.

NOTE:

- Apply engine oil to O-rings.
- Locate O-ring with white paint mark to engine front side.

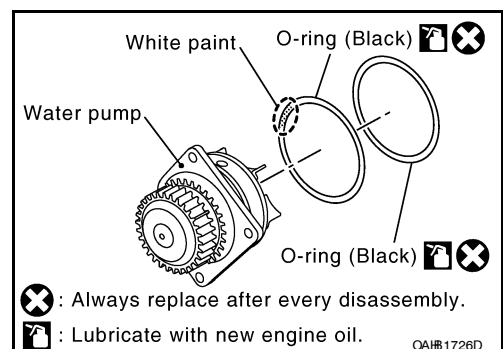

WATER PUMP

< ON-VEHICLE REPAIR >

[VQ40DE]

2. Install water pump.

CAUTION:

Do not allow timing chain case to pinch O-rings when installing water pump.

- Make sure that timing chain and water pump sprocket are engaged.
- Insert water pump by tightening bolts alternately and evenly.

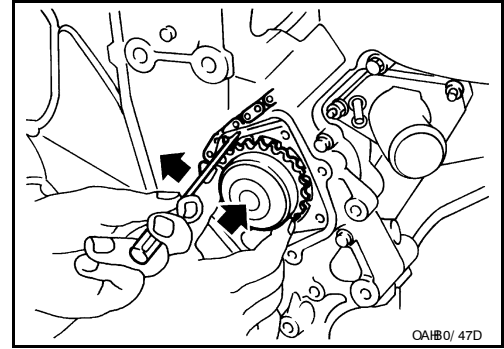

3. Install timing chain tensioner (primary) as follows:

- Remove dust and foreign material completely from backside of timing chain tensioner (primary) and from installation area of rear timing chain case.
- Turn crankshaft pulley clockwise so that timing chain on the timing chain tensioner (primary) side is loose.
- Install timing chain tensioner (primary) with its stopper pin attached.

CAUTION:

Be careful not to drop bolts inside timing chain case.

- Remove stopper pin.

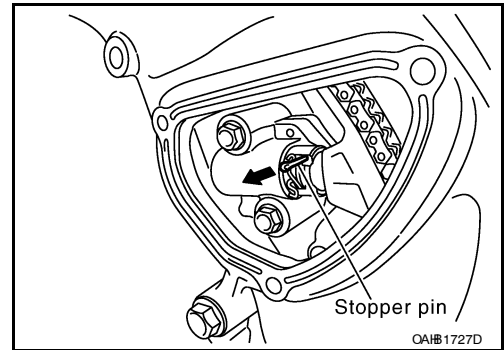

- Make sure again that timing chain and water pump sprocket are engaged.

4. Install chain tensioner cover and water pump cover as follows:

- Before installing, remove all traces of old liquid gasket from mating surface of water pump cover and chain tensioner cover using scraper. Also remove traces of old liquid gasket from the mating surface of front timing chain case.

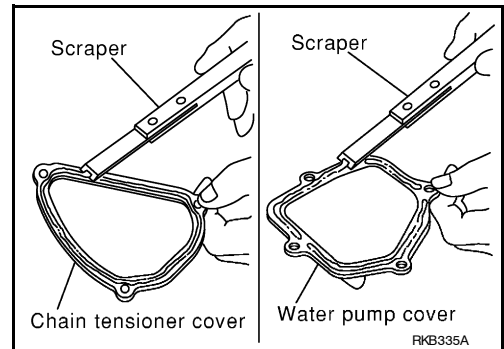

- Apply a continuous bead of liquid gasket, to mating surface of chain tensioner and water pump cover, using Tool.

Tool number : WS39930000 (—)

Use Genuine RTV Silicone Sealant or equivalent. Refer to [GI-14, "Recommended Chemical Products and Sealants"](#).

CAUTION:

Attaching should be done within 5 minutes after coating.

- Tighten bolts to specified torque. Refer to [EM-49, "Exploded View"](#).

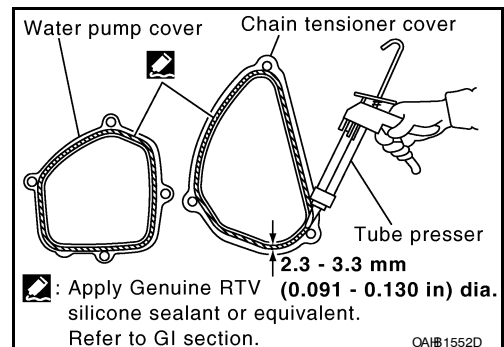

WATER PUMP

< ON-VEHICLE REPAIR >

[VQ40DE]

5. Refill engine coolant system. Refer to [CO-11, "Changing Engine Coolant"](#).
 - Apply liquid gasket to the thread of water drain plug (front).
Use Genuine RTV Silicone Sealant or equivalent. Refer to [GI-14, "Recommended Chemical Products and Sealants"](#).
6. Installation of the remaining components is in the reverse order of removal after this step.
 - **After starting engine, let idle for three minutes, then rev engine up to 3,000 rpm under no load to purge air from the high-pressure chamber of chain tensioner. Engine may produce a rattling noise. This indicates that air still remains in the chamber and is not a matter of concern.**

INSPECTION AFTER INSTALLATION

- Check for leaks of engine coolant. Refer to [CO-10, "System Inspection"](#).
- Start and warm up engine. Visually check there are no leaks of engine coolant.

A
CO
C
D
E
F
G
H
I
J
K
L
M
N
O
P

WATER INLET AND THERMOSTAT ASSEMBLY

< ON-VEHICLE REPAIR >

[VQ40DE]

WATER INLET AND THERMOSTAT ASSEMBLY

Exploded View

INFOID:000000004063650

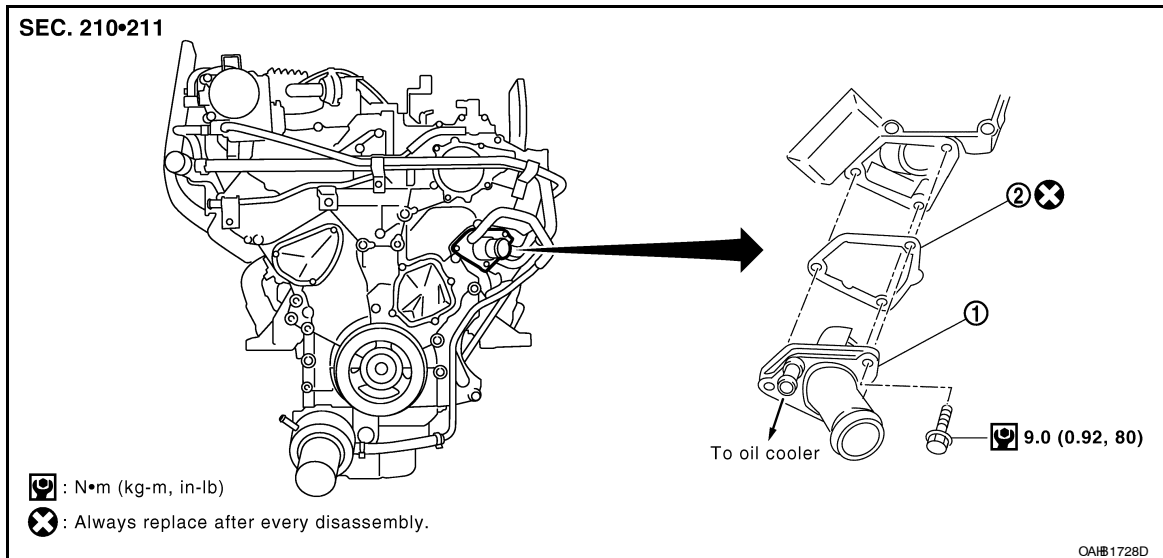

1. Water inlet and thermostat assembly
2. Gasket

Removal and Installation

INFOID:000000004063651

REMOVAL

1. Drain engine coolant from the radiator. Refer to [CO-11, "Changing Engine Coolant"](#).
CAUTION:
 - Perform this step when engine is cold.
 - Do not spill engine coolant on drive belts.
2. Remove air duct and resonator assembly. Refer to [EM-24, "Removal and Installation"](#).
3. Disconnect radiator hose (lower) and oil cooler hose from water inlet and thermostat assembly.
4. Remove water inlet and thermostat assembly.
CAUTION:
 - Do not disassemble water inlet and thermostat assembly.
 - Replace water inlet and thermostat assembly as a unit, if necessary.

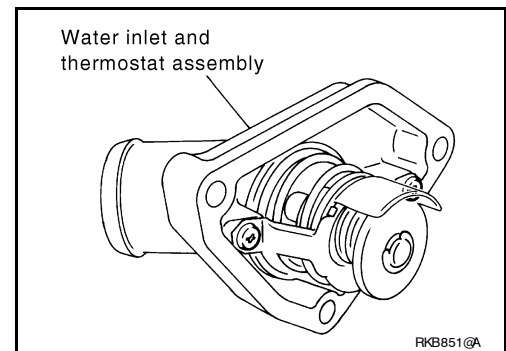

INSPECTION AFTER REMOVAL

1. Check valve seating condition at ordinary room temperatures. It should seat tightly.

WATER INLET AND THERMOSTAT ASSEMBLY

< ON-VEHICLE REPAIR >

[VQ40DE]

2. Check valve operation.
 - Place a thread so that it is caught in the valve of the thermostat. Immerse fully in a container filled with water. Heat while stirring.
 - The valve opening temperature is the temperature at which the valve opens and falls from the thread.
 - Continue heating. Check the full-open lift amount.
 - After checking the full-open lift amount, lower the water temperature and check the valve closing temperature.

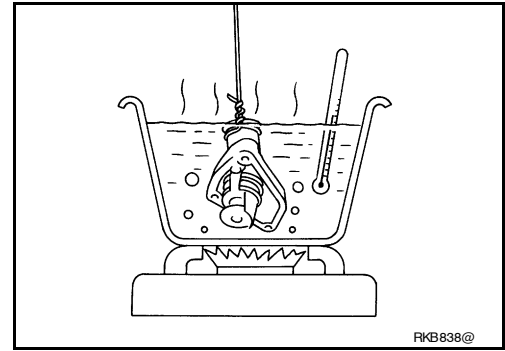

Thermostat	Standard
Valve opening temperature	80.5 - 83.5°C (177 - 182°F)
Full-open lift amount	8.6 mm / 95°C (0.339 in / 203°F)
Valve closing temperature	77°C (171°F)

- If valve seating at ordinary room temperature, or measured values are out of standard, replace water inlet and thermostat assembly.

INSTALLATION

Installation is in the reverse order of removal, paying attention to the following.

- **Do not spill engine coolant in engine room. Use rag to absorb engine coolant.**

INSPECTION AFTER INSTALLATION

- Check for leaks of engine coolant. Refer to [CO-10, "System Inspection"](#).
- Start and warm up engine. Visually check for leaks of engine coolant.

WATER OUTLET AND WATER PIPING

< ON-VEHICLE REPAIR >

[VQ40DE]

- Start and warm up engine. Visually check for leaks of engine coolant.

A

CO

C

D

E

F

G

H

I

J

K

L

M

N

O

P

SERVICE DATA AND SPECIFICATIONS (SDS)

< SERVICE DATA AND SPECIFICATIONS (SDS)

[VQ40DE]

SERVICE DATA AND SPECIFICATIONS (SDS)

SERVICE DATA AND SPECIFICATIONS (SDS)

Standard and Limit

INFOID:000000004063654

ENGINE COOLANT CAPACITY (APPROXIMATE)

Unit: ℓ (US qt, Imp qt)

Engine coolant capacity (With reservoir tank at "MAX" level)	10.2 (10-3/4, 9)
--	------------------

RADIATOR

Unit: kPa (kg/cm², psi)

Cap relief pressure	Standard	78 - 98 (0.8 - 1.0, 11 - 14)
	Limit	59 (0.6, 9)
Leakage testing pressure		137 (1.4, 20)

THERMOSTAT

Valve opening temperature	80.5 - 83.5°C (177 - 182°F)
Full-open lift amount	8.6 mm / 95°C (0.339 in / 203°F)
Valve closing temperature	77°C (171°F)