

# SECTION **BRC**

## BRAKE CONTROL SYSTEM

A  
B  
C  
D  
E

### CONTENTS

<b>ABS</b>	
<b>PRECAUTIONS</b> .....	<b>4</b>
Precautions for Supplemental Restraint System (SRS) "AIR BAG" and "SEAT BELT PRE-TENSIONER" .....	4
Precautions for Brake System .....	4
Precautions When Using CONSULT-II .....	4
CHECK POINTS FOR USING CONSULT-II .....	4
Precautions for Brake Control .....	5
Precautions for CAN System .....	5
Wiring Diagrams and Trouble Diagnosis .....	6
<b>PREPARATION</b> .....	<b>7</b>
Special Service Tool .....	7
Commercial Service Tools .....	7
<b>SYSTEM DESCRIPTION</b> .....	<b>8</b>
System Diagram .....	8
ABS Function .....	8
EBD Function .....	8
Wheel Sensors .....	9
Fail-Safe Function .....	9
ABS/EBD SYSTEM .....	9
Hydraulic Circuit Diagram .....	10
<b>CAN COMMUNICATION</b> .....	<b>11</b>
System Description .....	11
<b>TROUBLE DIAGNOSIS</b> .....	<b>12</b>
How to Perform Trouble Diagnoses for Quick and Accurate Repair .....	12
INTRODUCTION .....	12
WORK FLOW .....	13
CLARIFY CONCERN .....	14
EXAMPLE OF DIAGNOSIS SHEET .....	14
Component Parts and Harness Connector Location .....	15
Schematic .....	16
Wiring Diagram — ABS — .....	17
Basic Inspection .....	21
BRAKE FLUID LEVEL, FLUID LEAK, AND BRAKE PAD INSPECTION .....	21
POWER SYSTEM TERMINAL LOOSENESS AND BATTERY INSPECTION .....	21
ABS WARNING LAMP INSPECTION .....	21
Warning Lamp and Indicator Timing .....	21
Control Unit Input/Output Signal Standard .....	22
REFERENCE VALUE FROM CONSULT-II .....	22
CONSULT-II Function (ABS) .....	24
CONSULT-II BASIC OPERATION PROCEDURE .....	24
SELF-DIAGNOSIS .....	25
DATA MONITOR .....	27
ACTIVE TEST .....	29
<b>TROUBLE DIAGNOSIS FOR SELF-DIAGNOSTIC ITEMS</b> .....	<b>31</b>
Wheel Sensor System Inspection .....	31
Engine System Inspection .....	32
ABS Control Unit Inspection .....	33
Actuator Motor, Motor Relay, and Circuit Inspection .....	33
Stop Lamp Switch System Inspection .....	34
ABS Control Unit Power and Ground Systems Inspection .....	35
CAN Communication System Inspection .....	36
<b>TROUBLE DIAGNOSES FOR SYMPTOMS</b> .....	<b>37</b>
ABS Works Frequently .....	37
Unexpected Pedal Action .....	38
Long Stopping Distance .....	39
ABS Does Not Work .....	39
Pedal Vibration or ABS Operation Noise .....	39
ABS Warning Lamp Does Not Come On When Ignition Switch Is Turned On .....	40
ABS Warning Lamp Stays On When Ignition Switch Is Turned On .....	40
<b>WHEEL SENSORS</b> .....	<b>41</b>
Removal and Installation .....	41
<b>SENSOR ROTOR</b> .....	<b>42</b>
Removal and Installation .....	42
REMOVAL .....	42
INSTALLATION .....	42
<b>ACTUATOR AND ELECTRIC UNIT (ASSEMBLY)...</b>	<b>43</b>
Removal and Installation .....	43
REMOVAL .....	43
INSTALLATION .....	43

BRC

G  
H  
I  
J  
K  
L  
M

## TCS/ABS

<b>PRECAUTIONS</b> .....	<b>45</b>
Precautions for Supplemental Restraint System (SRS) "AIR BAG" and "SEAT BELT PRE-TENSIONER" .....	45
Precautions for Brake System .....	45
Precautions When Using CONSULT-II .....	45
CHECK POINTS FOR USING CONSULT-II .....	45
Precautions for Brake Control .....	46
Precautions for CAN System .....	46
Wiring Diagrams and Trouble Diagnosis .....	47
<b>PREPARATION</b> .....	<b>48</b>
Special Service Tool .....	48
Commercial Service Tools .....	48
<b>SYSTEM DESCRIPTION</b> .....	<b>49</b>
System Diagram .....	49
ABS Function .....	49
EBD Function .....	49
TCS Function .....	49
Wheel Sensors .....	50
Fail-Safe Function .....	50
ABS/EBD SYSTEM .....	50
TCS SYSTEM .....	50
Hydraulic Circuit Diagram .....	51
<b>CAN COMMUNICATION</b> .....	<b>52</b>
System Description .....	52
<b>TROUBLE DIAGNOSIS</b> .....	<b>53</b>
How to Perform Trouble Diagnoses for Quick and Accurate Repair .....	53
INTRODUCTION .....	53
WORK FLOW .....	54
CLARIFY CONCERN .....	55
EXAMPLE OF DIAGNOSIS SHEET .....	55
Component Parts and Harness Connector Location..	56
Schematic .....	57
Wiring Diagram — TCS — .....	58
Basic Inspection .....	62
BRAKE FLUID LEVEL, FLUID LEAK, AND BRAKE PAD INSPECTION .....	62
POWER SYSTEM TERMINAL LOOSENESS AND BATTERY INSPECTION .....	62
ABS WARNING LAMP AND SLIP INDICATOR LAMP INSPECTION .....	62
Warning Lamp and Indicator Timing .....	62
Control Unit Input/Output Signal Standard .....	63
REFERENCE VALUE FROM CONSULT-II .....	63
CONSULT-II Function (ABS) .....	65
CONSULT-II BASIC OPERATION PROCEDURE .....	65
SELF-DIAGNOSIS .....	66
DATA MONITOR .....	68
ACTIVE TEST .....	70
<b>TROUBLE DIAGNOSIS FOR SELF-DIAGNOSTIC ITEMS</b> .....	<b>72</b>
Wheel Sensor System Inspection .....	72
Engine System Inspection .....	73
ABS/TCS Control Unit Inspection .....	74
Actuator Motor, Motor Relay, and Circuit Inspection..	74

Stop Lamp Switch System Inspection .....	75
ABS/TCS Control Unit Power and Ground Systems Inspection .....	76
CAN Communication System Inspection .....	77
<b>TROUBLE DIAGNOSES FOR SYMPTOMS</b> .....	<b>78</b>
ABS Works Frequently .....	78
Unexpected Pedal Action .....	79
Long Stopping Distance .....	80
ABS Does Not Work .....	80
Pedal Vibration or ABS Operation Noise .....	80
ABS Warning Lamp Does Not Come On When Ignition Switch Is Turned On .....	81
ABS Warning Lamp Stays On When Ignition Switch Is Turned On .....	81
Vehicle Jerks During TCS Activation .....	82
<b>WHEEL SENSORS</b> .....	<b>83</b>
Removal and Installation .....	83
<b>SENSOR ROTOR</b> .....	<b>84</b>
Removal and Installation .....	84
REMOVAL .....	84
INSTALLATION .....	84
<b>ACTUATOR AND ELECTRIC UNIT (ASSEMBLY)</b> .....	<b>85</b>
Removal and Installation .....	85
REMOVAL .....	85
INSTALLATION .....	85

## VDC/TCS/ABS

<b>PRECAUTIONS</b> .....	<b>87</b>
Precautions for Supplemental Restraint System (SRS) "AIR BAG" and "SEAT BELT PRE-TENSIONER" .....	87
Precautions for Brake System .....	87
Precautions When Using CONSULT-II .....	87
CHECK POINTS FOR USING CONSULT-II .....	87
Precautions for Brake Control .....	88
Precautions for CAN System .....	88
Wiring Diagrams and Trouble Diagnosis .....	89
<b>PREPARATION</b> .....	<b>90</b>
Special Service Tool .....	90
Commercial Service Tools .....	90
<b>SYSTEM DESCRIPTION</b> .....	<b>91</b>
System Components .....	91
ABS Function .....	91
EBD Function .....	91
TCS Function .....	92
VDC Function .....	92
Wheel Sensors .....	93
Fail-Safe Function .....	93
ABS/EBD SYSTEM .....	93
VDC/TCS SYSTEM .....	93
Hydraulic Circuit Diagram .....	94
<b>CAN COMMUNICATION</b> .....	<b>95</b>
System Description .....	95
<b>TROUBLE DIAGNOSIS</b> .....	<b>96</b>
How to Perform Trouble Diagnoses for Quick and Accurate Repair .....	96
INTRODUCTION .....	96
WORK FLOW .....	96

CLARIFY CONCERN .....	98	Brake Fluid Level Sensor System Inspection .....	128	
EXAMPLE OF DIAGNOSIS SHEET .....	98	CAN Communication System Inspection .....	128	A
Component Parts and Harness Connector Location .....	99	Component Inspection .....	129	
Schematic .....	100	VDC OFF SWITCH .....	129	
Wiring Diagram — VDC — .....	101	<b>TROUBLE DIAGNOSES FOR SYMPTOMS .....</b>	<b>130</b>	B
Basic Inspection .....	107	ABS Works Frequently .....	130	
BRAKE FLUID LEVEL, FLUID LEAK, AND		Unexpected Pedal Action .....	131	
BRAKE PAD INSPECTION .....	107	Long Stopping Distance .....	132	C
POWER SYSTEM TERMINAL LOOSENESS		ABS Does Not Work .....	132	
AND BATTERY INSPECTION .....	107	Pedal Vibration or ABS Operation Noise .....	132	
ABS WARNING LAMP, SLIP INDICATOR LAMP		ABS Warning Lamp Does Not Come On When Igni-		
AND VDC OFF INDICATOR LAMP INSPECTION	107	tion Switch Is Turned On .....	133	D
Warning Lamp and Indicator Timing .....	107	ABS Warning Lamp Stays On When Ignition Switch		
Control Unit Input/Output Signal Standard .....	108	Is Turned On .....	133	
REFERENCE VALUE FROM CONSULT-II .....	108	Vehicle Jerks During TCS/VDC Activation .....	134	E
CONSULT-II Function (ABS) .....	111	<b>ON-VEHICLE SERVICE .....</b>	<b>135</b>	
CONSULT-II BASIC OPERATION PROCEDURE		Adjustment of Steering Angle Sensor Neutral Posi-		
..	112	tion .....	135	
SELF-DIAGNOSIS .....	112	<b>WHEEL SENSORS .....</b>	<b>136</b>	BRC
DATA MONITOR .....	115	Removal and Installation .....	136	
ACTIVE TEST .....	117	<b>SENSOR ROTOR .....</b>	<b>137</b>	
<b>TROUBLE DIAGNOSIS FOR SELF-DIAGNOSTIC</b>		Removal and Installation .....	137	G
<b>ITEMS .....</b>	<b>119</b>	REMOVAL .....	137	
Wheel Sensor System Inspection .....	119	INSTALLATION .....	137	
Engine System Inspection .....	120	<b>ACTUATOR AND ELECTRIC UNIT (ASSEMBLY).</b>	<b>138</b>	H
ABS/TCS/VDC Control Unit Inspection .....	121	Removal and Installation .....	138	
Steering Angle Sensor System Inspection .....	121	REMOVAL .....	138	
Yaw Rate/Side/Decel G Sensor System Inspection	122	INSTALLATION .....	138	I
Solenoid and VDC Change-Over Valve System		<b>STEERING ANGLE SENSOR .....</b>	<b>140</b>	
Inspection .....	124	Removal and Installation .....	140	
Actuator Motor, Motor Relay, and Circuit Inspection	125	<b>G SENSOR .....</b>	<b>141</b>	J
Stop Lamp Switch System Inspection .....	126	Removal and Installation .....	141	
ABS/TCS/VDC Control Unit Power and Ground		REMOVAL .....	141	
Systems Inspection .....	127	INSTALLATION .....	141	K

**PRECAUTIONS**

PFP:00001

**Precautions for Supplemental Restraint System (SRS) “AIR BAG” and “SEAT BELT PRE-TENSIONER”**

EFS002PT

The Supplemental Restraint System such as “AIR BAG” and “SEAT BELT PRE-TENSIONER”, used along with a front seat belt, helps to reduce the risk or severity of injury to the driver and front passenger for certain types of collision. Information necessary to service the system safely is included in the SRS and SB section of this Service Manual.

**WARNING:**

- To avoid rendering the SRS inoperative, which could increase the risk of personal injury or death in the event of a collision which would result in air bag inflation, all maintenance must be performed by an authorized NISSAN/INFINITI dealer.
- Improper maintenance, including incorrect removal and installation of the SRS, can lead to personal injury caused by unintentional activation of the system. For removal of Spiral Cable and Air Bag Module, see the SRS section.
- Do not use electrical test equipment on any circuit related to the SRS unless instructed to in this Service Manual. SRS wiring harnesses can be identified by yellow and/or orange harnesses or harness connectors.

**Precautions for Brake System**

EFS002PU

**CAUTION:**

- Recommended fluid is brake fluid “DOT 3”.
- Never reuse drained brake fluid.
- Be careful not to splash brake fluid on painted areas; it may cause paint damage. If brake fluid is splashed on painted areas, wash it away with water immediately.
- To clean or wash all parts of master cylinder and disc brake caliper, use clean brake fluid.
- Never use mineral oils such as gasoline or kerosene. They will ruin rubber parts of the hydraulic system.
- Use flare nut wrench when removing and installing brake tube.
- If a brake fluid leak is found, the part must be disassembled without fail. Then it has to be replaced with a new one if a defect exists.
- Turn the ignition switch OFF and remove the connector of the ABS actuator control unit or the battery terminal before performing the work.
- Always torque brake lines when installing.
- Burnish the brake contact surfaces after refinishing or replacing rotors, after replacing pads, or if a soft pedal occurs at very low mileage.

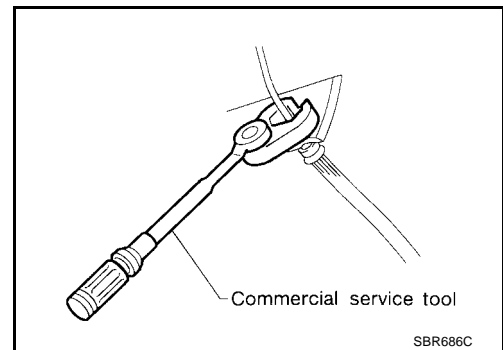

SBR686C

Refer to [BR-28. "Brake Burnishing"](#) (front disc brake) or [BR-35. "Brake Burnishing"](#) (Rear disc brake).

**WARNING:**

- Clean brake pads and shoes with a waste cloth, then wipe with a dust collector.

**Precautions When Using CONSULT-II**

EFS0031O

When connecting CONSULT-II to data link connector, connect them through CONSULT-II CONVERTER.

**CAUTION:**

If CONSULT-II is used with no connection of CONSULT-II CONVERTER, malfunctions might be detected in self-diagnosis depending on control unit which carry out CAN communication.

**CHECK POINTS FOR USING CONSULT-II**

1. Has CONSULT-II been used without connecting CONSULT-II CONVERTER on this vehicle?
  - If YES, GO TO 2.
  - If NO, GO TO 5.

# PRECAUTIONS

[ABS]

2. Is there any indication other than indications relating to CAN communication system in the self-diagnosis results?
  - If YES, GO TO 3.
  - If NO, GO TO 4.
3. Based on self-diagnosis results unrelated to CAN communication, carry out the inspection.
4. Malfunctions may be detected in self-diagnosis depending on control units carrying out CAN communication. Therefore, erase the self-diagnosis results.
5. Diagnose CAN communication system. Refer to [LAN-8, "CAN COMMUNICATION"](#).

## Precautions for Brake Control

EFS002UZ

- During ABS operation, the brake pedal may vibrate lightly and a mechanical noise may be heard. This is normal.
- Just after starting vehicle, the brake pedal may vibrate or a motor operating noise may be heard from engine compartment. This is a normal status of operation check.
- Stopping distance may be longer than that of vehicles without ABS when vehicle drives on rough, gravel, or snow-covered (fresh, deep snow) roads.
- When an error is indicated by ABS or another warning lamp, collect all necessary information from customer (what symptoms are present under what conditions) and check for simple causes before starting diagnosis. Besides electrical system inspection, check booster operation, brake fluid level, and fluid leaks.
- If incorrect tire sizes or types are installed on the vehicle or brake pads are not Genuine NISSAN parts, stopping distance or steering stability may deteriorate.
- If there is a radio, antenna or related wiring near control module, ABS function may have a malfunction or error.
- If aftermarket parts (car stereo, CD player, etc.) have been installed, check for incidents such as harness pinches, open circuits or improper wiring.

## Precautions for CAN System

EFS002V2

- Do not apply voltage of 7.0V or higher to terminal to be measured.
- Maximum open terminal voltage of tester in use must be less than 7.0V.
- Before checking harnesses, turn ignition switch OFF and disconnect battery negative cable.
- Area to be repaired must be soldered and wrapped with tape. Make sure that fraying of twisted wire is within 110 mm (4.33 in).

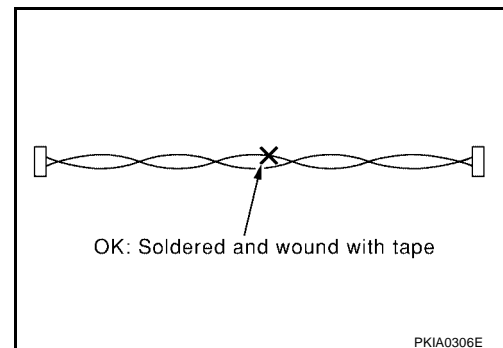

- Do not make a bypass connection to repaired area. (If the circuit is bypassed, characteristics of twisted wire will be lost.)

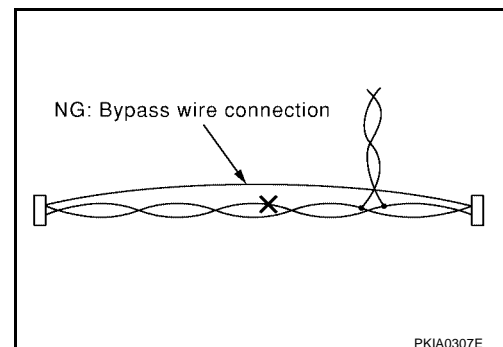

---

## Wiring Diagrams and Trouble Diagnosis

When you read wiring diagrams, refer to the following:

- [GI-12, "How to Read Wiring Diagrams"](#)
- [PG-3, "POWER SUPPLY ROUTING CIRCUIT"](#)

When you perform trouble diagnosis, refer to the following:

- [GI-10, "HOW TO FOLLOW TEST GROUPS IN TROUBLE DIAGNOSES"](#)
- [GI-25, "How to Perform Efficient Diagnosis for an Electrical Incident"](#)

# PREPARATION

**[ABS]**

## PREPARATION

PFP:00002

### Special Service Tool

EFS002VV

The actual shapes of Kent-Moore tools may differ from those of special service tools illustrated here.

Tool number (Kent-Moore No.) Tool name	Description
(J-45741) ABS active wheel sensor tester	Checking operation of ABS active wheel sensor

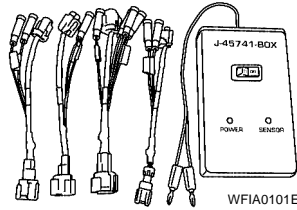

### Commercial Service Tools

EFS002VV

Tool name	Description
1. Flare nut crowfoot a: 10mm (0.39 in)/12mm (0.47 in) 2. Torque wrench	Removing and installing brake piping

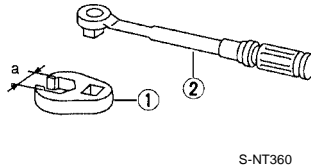

A  
B  
C  
D  
E  
**BRC**  
G  
H  
I  
J  
K  
L  
M

## SYSTEM DESCRIPTION

PFP:00000

### System Diagram

EFS002VF

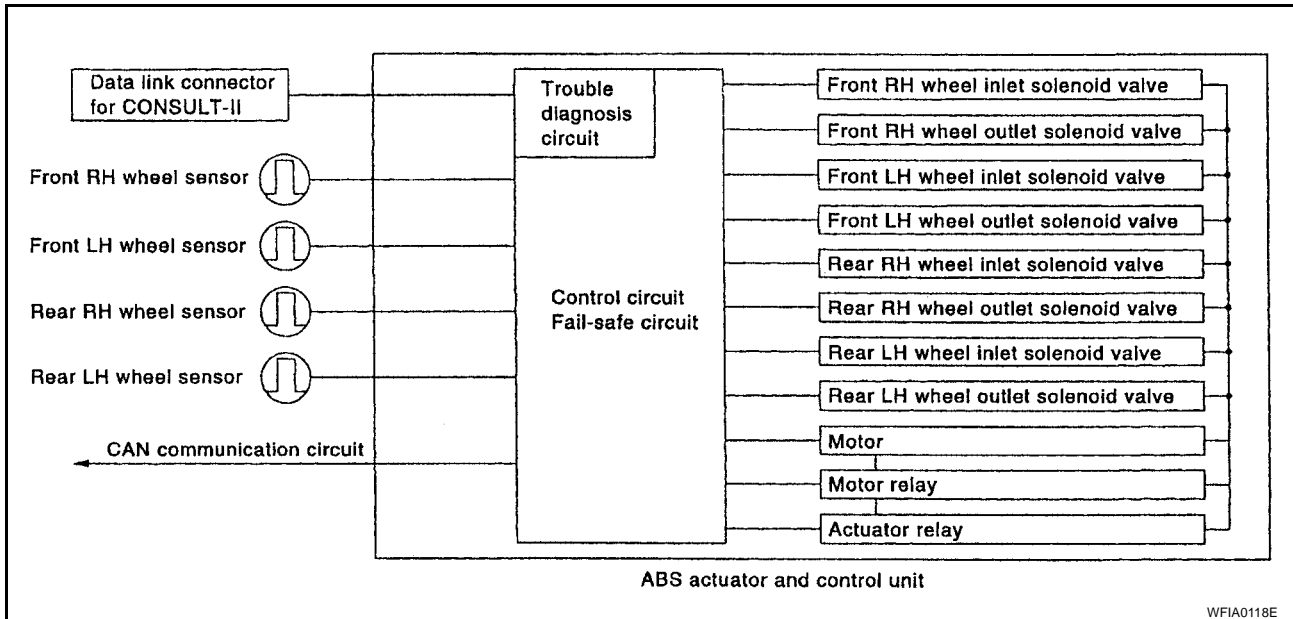

### ABS Function

EFS002VG

- The Anti-Lock Brake System detects wheel revolution while braking and improves handling stability during sudden braking by electrically preventing wheel lockup. Maneuverability is also improved for avoiding obstacles.
- If the electrical system malfunctions, the Fail-Safe function is activated, the ABS becomes inoperative and the ABS warning lamp turns on.
- The electrical system can be diagnosed using CONSULT-II.
- During ABS operation, the brake pedal may vibrate lightly and a mechanical noise may be heard. This is normal.
- Just after starting the vehicle, the brake pedal may vibrate or a motor operating noise may be heard from engine compartment. This is a normal status of operation check.
- Stopping distance may be longer than that of vehicles without ABS when vehicle drives on rough, gravel, or snow-covered (fresh, deep snow) roads.

### EBD Function

EFS002VH

- Electronic Brake Distribution is a function that detects subtle slippages between the front and rear wheels during braking, and it improves handling stability by electronically controlling the brake fluid pressure which results in reduced rear wheel slippage.
- If the electrical system malfunctions, the Fail-Safe function is activated, the EBD and ABS become inoperative, and the ABS warning lamp and BRAKE warning lamp are turned on.
- The electrical system can be diagnosed using CONSULT-II.
- During EBD operation, the brake pedal may vibrate lightly and a mechanical noise may be heard. This is normal.
- Just after starting the vehicle, the brake pedal may vibrate or a motor operating noise may be heard from engine compartment. This is a normal status of operation check.
- Stopping distance may be longer than that of vehicles without EBD when vehicle drives on rough, gravel, or snow-covered (fresh, deep snow) roads.



## Wheel Sensors

The front sensor units consist of a gear-shaped sensor rotor and a sensor element. The element contains a magnet around which a coil is wound. The front wheel sensors are installed on the front of the wheel knuckles. As the wheel rotates, the sensor generates a square-wave signal. The frequency increases as the wheel speed increases.

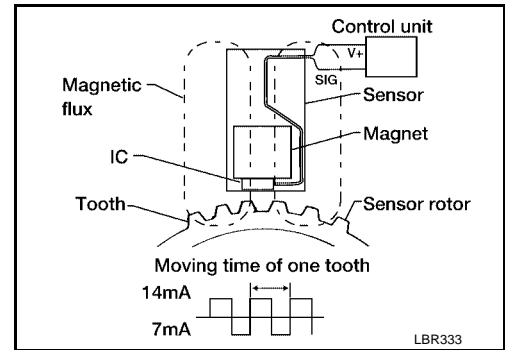

The rear sensor units consist of wheel hubs with a series of internal magnets and a sensor element. The rear wheel sensors are installed on the inner side of the wheel knuckles. As the wheel rotates, the sensor generates a square-wave signal. The frequency increases as the wheel speed increases.

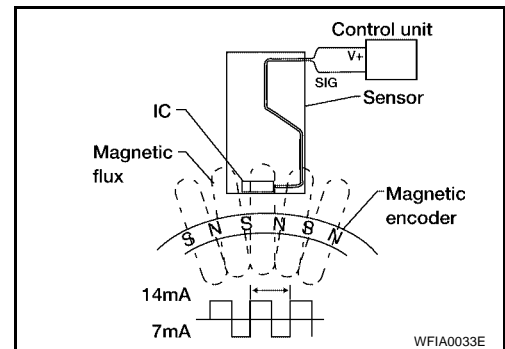

## Fail-Safe Function

**CAUTION:**

If the Fail-Safe function is activated, perform the Self Diagnosis for ABS system.

### ABS/EBD SYSTEM

In case of an electrical malfunction with the ABS, the ABS warning lamp will turn on. In case of an electrical malfunction with the EBD system, the BRAKE warning lamp and the ABS warning lamp will turn on. The system will revert to one of the following conditions of the Fail-Safe function.

1. For ABS malfunction, only the EBD is operative and the condition of the vehicle is the same condition of vehicles without ABS system.
2. For EBD malfunction, the EBD and ABS become inoperative, and the condition of the vehicle is the same as the condition of vehicles without ABS or EBD system.

A  
B  
C  
D  
E  
BRC  
G  
H  
I  
J  
K  
L  
M

# SYSTEM DESCRIPTION

[ABS]

## Hydraulic Circuit Diagram

EFS002VL

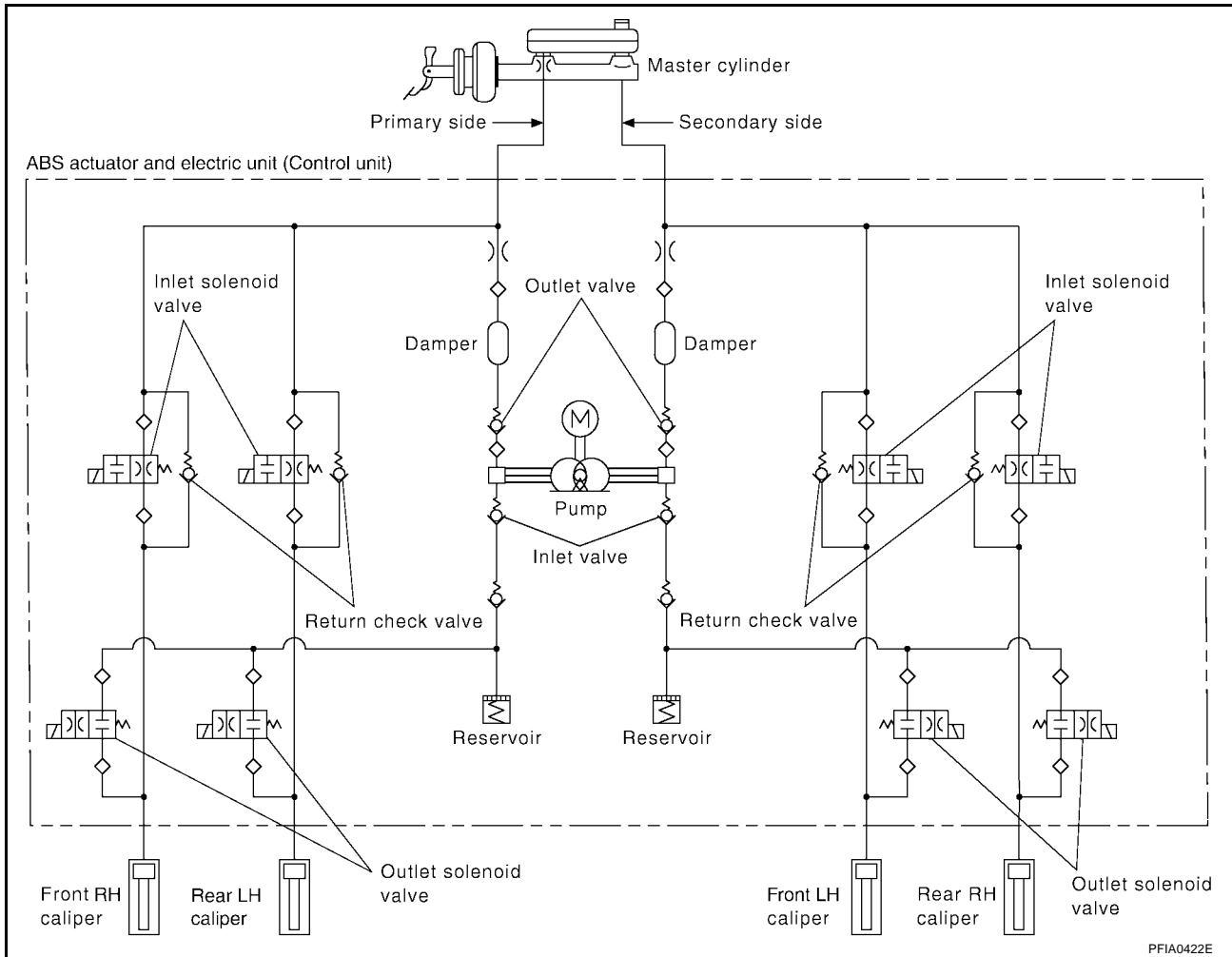

---

**CAN COMMUNICATION**

PFP:23710

**System Description**

EPS002W0

Refer to [LAN-8, "CAN COMMUNICATION"](#) .

A

B

C

D

E

**BRC**

G

H

I

J

K

L

M

## TROUBLE DIAGNOSIS

### How to Perform Trouble Diagnoses for Quick and Accurate Repair INTRODUCTION

The ABS system has an electronic control unit to control major functions. The control unit accepts input signals from sensors and controls actuator operation. It is also important to check for conventional problems such as air leaks in the booster or lines, lack of brake fluid, or other problems with the brake system.

It is much more difficult to diagnose a problem that occurs intermittently rather than continuously. Most intermittent problems are caused by poor electrical connections or faulty wiring. In this case, careful checking of suspicious circuits may help prevent the replacement of good parts.

A visual check only may not find the cause of the problem, so a road test should be performed.

Before undertaking actual checks, take just a few minutes to talk with a customer who approaches with an ABS complaint. The customer is a very good source of information on such problems, especially intermittent ones. Through the talks with the customer, find out what symptoms are present and under what conditions they occur.

Start your diagnosis by looking for "conventional" problems first. This is one of the best ways to troubleshoot brake problems on an ABS equipped vehicle. Also check related Service Bulletins for information.

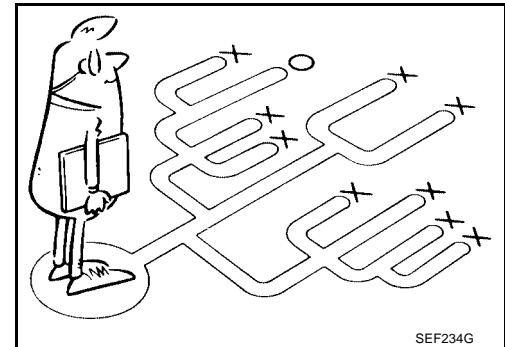
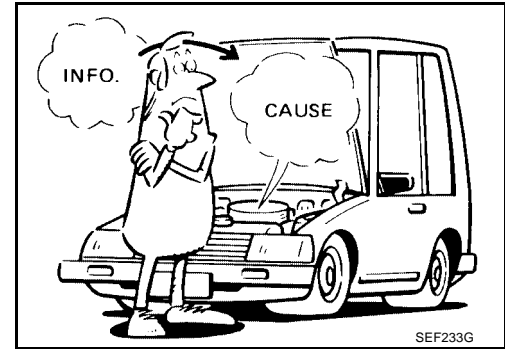

# TROUBLE DIAGNOSIS

[ABS]

## WORK FLOW

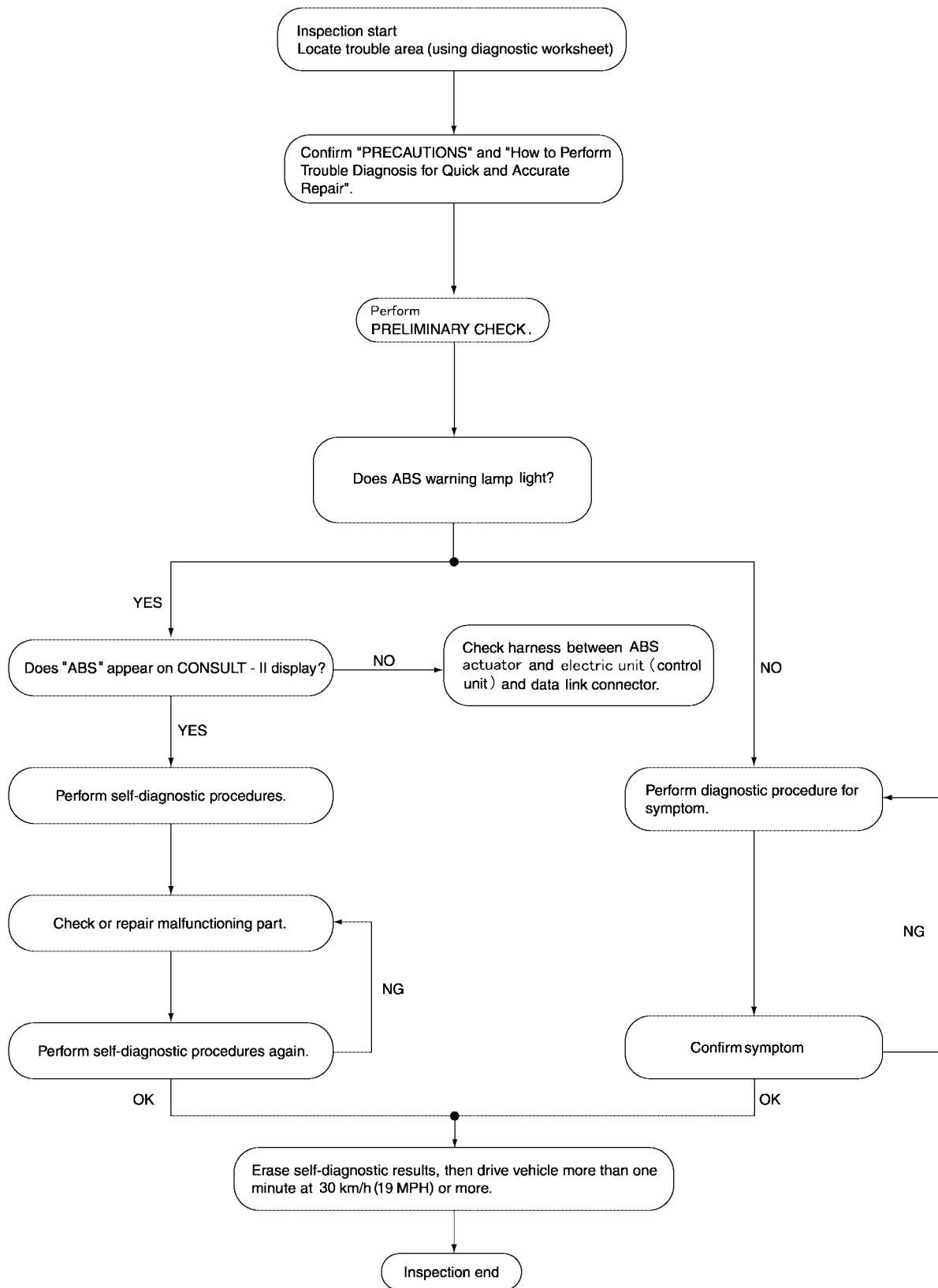

A  
B  
C  
D  
E  
BRC  
G  
H  
I  
J  
K  
L  
M

LFIA0197E

# TROUBLE DIAGNOSIS

[ABS]

## CLARIFY CONCERN

- A customer's description of a vehicle concern may vary depending on the individual. It is important to clarify the customer's concern.
- Ask the customer about what symptoms are present under what conditions. Use this information to reproduce the symptom while driving.
- It is also important to use the diagnosis sheet to understand what type of trouble the customer is having.

**KEY POINTS**

**WHAT** ..... Vehicle model  
**WHEN** ..... Date, Frequencies  
**WHERE** ..... Road conditions  
**HOW** ..... Operating conditions,  
 Weather conditions,  
 Symptoms

SBR339B

## EXAMPLE OF DIAGNOSIS SHEET

Customer name	Model & Year	VIN	
Engine #	Trans.	Mileage	
Incident Date	Manuf. Date	In Service Date	
Symptoms	<input type="checkbox"/> Noise and vibration (from engine compartment)	<input type="checkbox"/> ABS warning lamp activates	<input type="checkbox"/> Pedal operation
	<input type="checkbox"/> Noise and vibration (from axle)	<input type="checkbox"/> SLIP warning lamp activates	<input type="checkbox"/> Large stroke pedal operation
	<input type="checkbox"/> TCS does not work (drive wheels slip when accelerating)	<input type="checkbox"/> ABS does not work (wheels slip when braking)	<input type="checkbox"/> Firm pedal
	<input type="checkbox"/> Lack of sense of acceleration		
Engine conditions	<input type="checkbox"/> When starting <input type="checkbox"/> After starting		
Road conditions	<input type="checkbox"/> Low friction road ( <input type="checkbox"/> Snow <input type="checkbox"/> Gravel <input type="checkbox"/> Other ) <input type="checkbox"/> Bumps/potholes		
Driving conditions	<input type="checkbox"/> Full-acceleration <input type="checkbox"/> High speed cornering <input type="checkbox"/> Vehicle speed: Greater than 10 km/h (6 MPH) <input type="checkbox"/> Vehicle speed: 10 km/h (6 MPH) or less <input type="checkbox"/> Vehicle is stopped		
Applying brake conditions	<input type="checkbox"/> Suddenly <input type="checkbox"/> Gradually		
Other conditions	<input type="checkbox"/> Operation of electrical equipment <input type="checkbox"/> Shift change <input type="checkbox"/> Other descriptions		

WFIA0097E

## Component Parts and Harness Connector Location

EFS002Z4

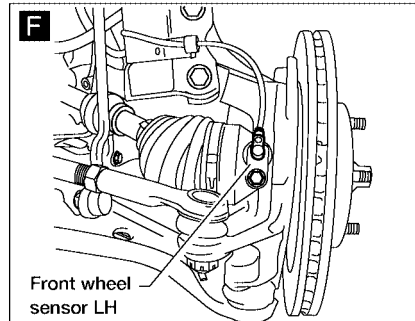
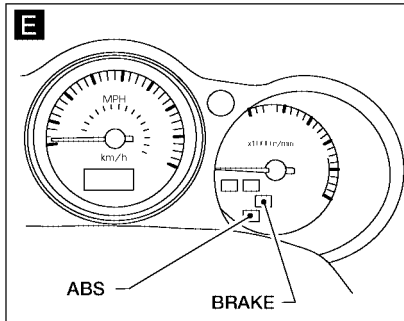
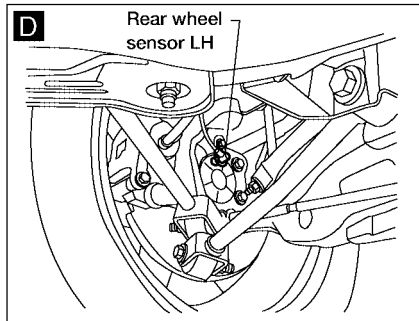
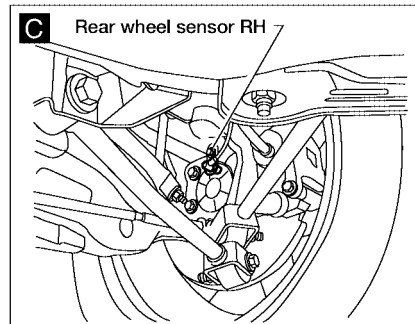
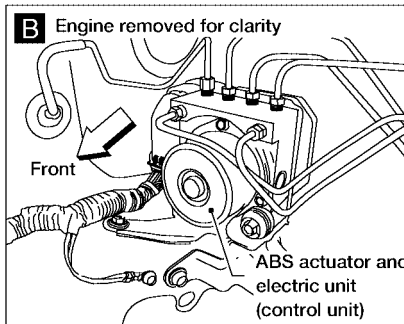
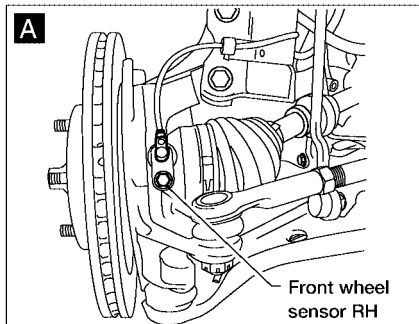
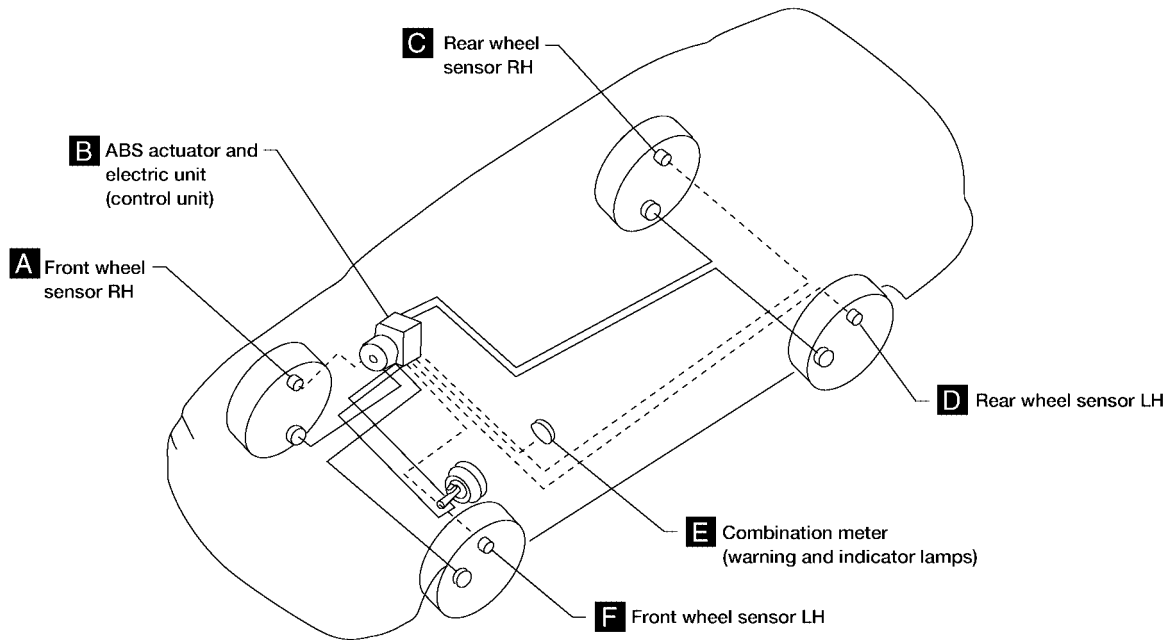

A  
B  
C  
D  
E  
BRC  
G  
H  
I  
J  
K  
L  
M

WFIA0099E

# TROUBLE DIAGNOSIS

[ABS]

## Schematic

EFS002Z5

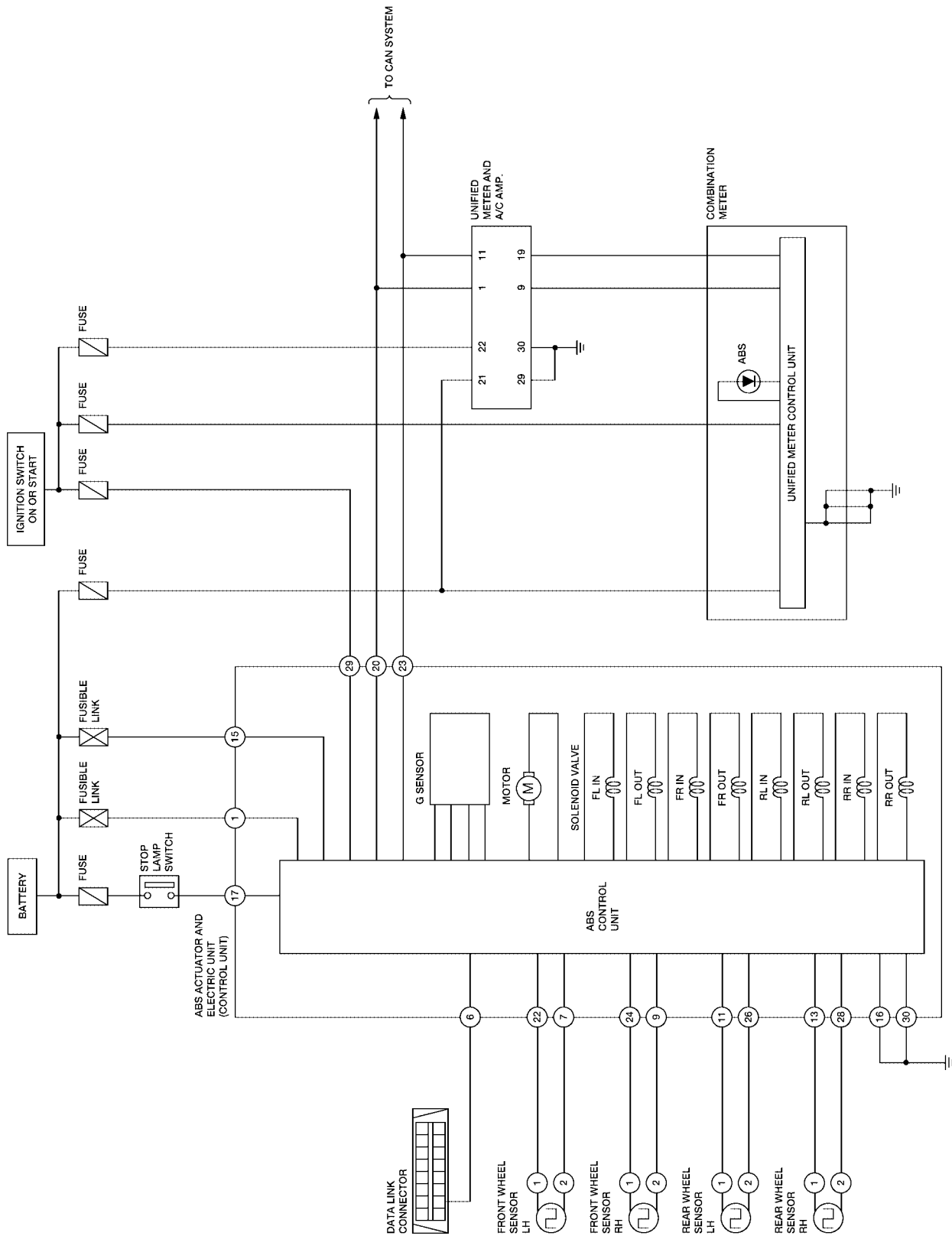

WFWA0016E



# TROUBLE DIAGNOSIS

[ABS]

## Wiring Diagram — ABS —

EFS002Z6

BRC-ABS-01

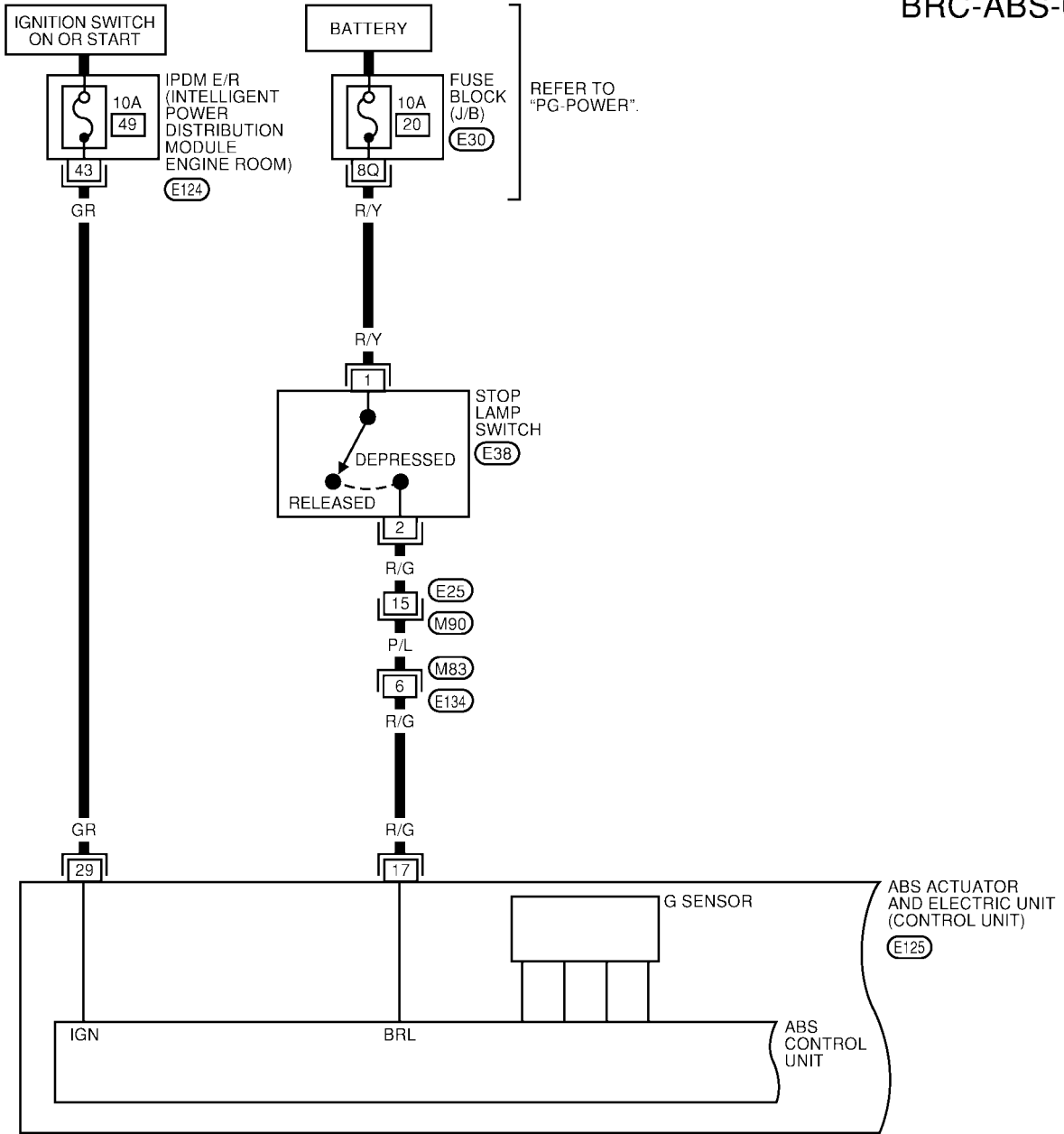

A  
B  
C  
D  
E  
**BRC**  
G  
H  
I  
J  
K  
L  
M

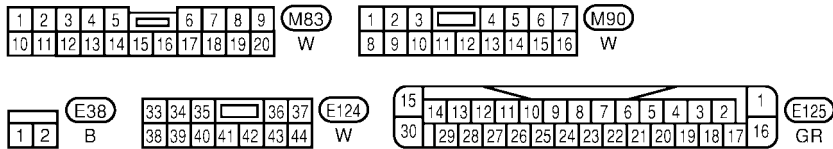

REFER TO THE FOLLOWING.  
 (E30) - FUSE BLOCK - JUNCTION BOX (J/B)

WFWA0017E

# TROUBLE DIAGNOSIS

[ABS]

BRC-ABS-02

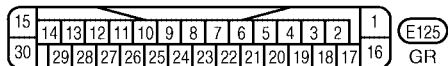
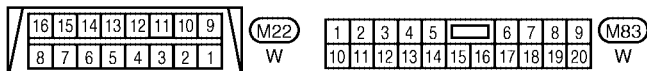
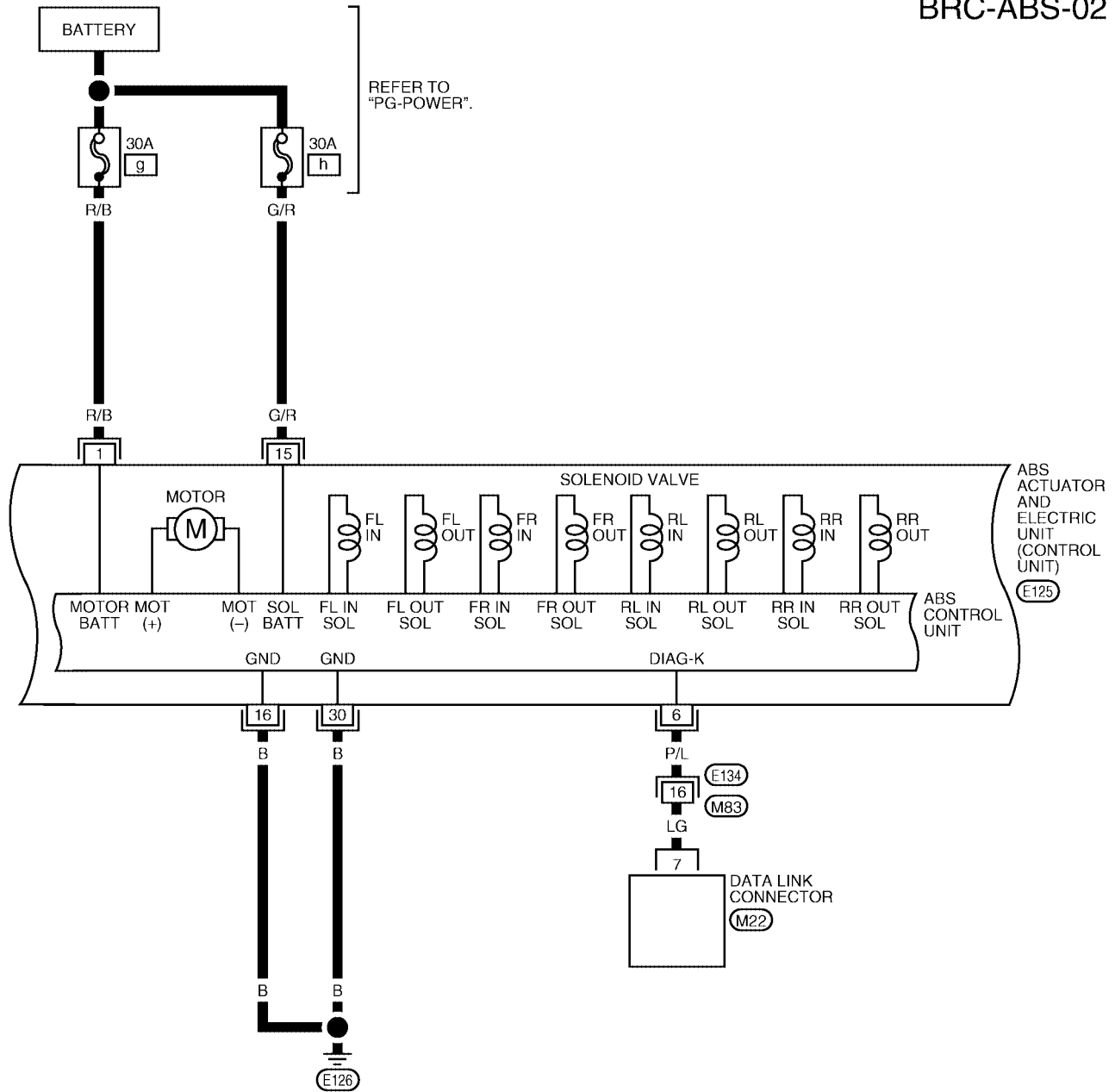

WFWA0018E

# TROUBLE DIAGNOSIS

[ABS]

BRC-ABS-03

— — — — — : DATA LINE

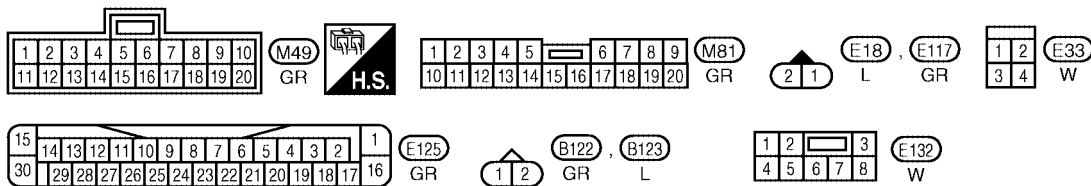
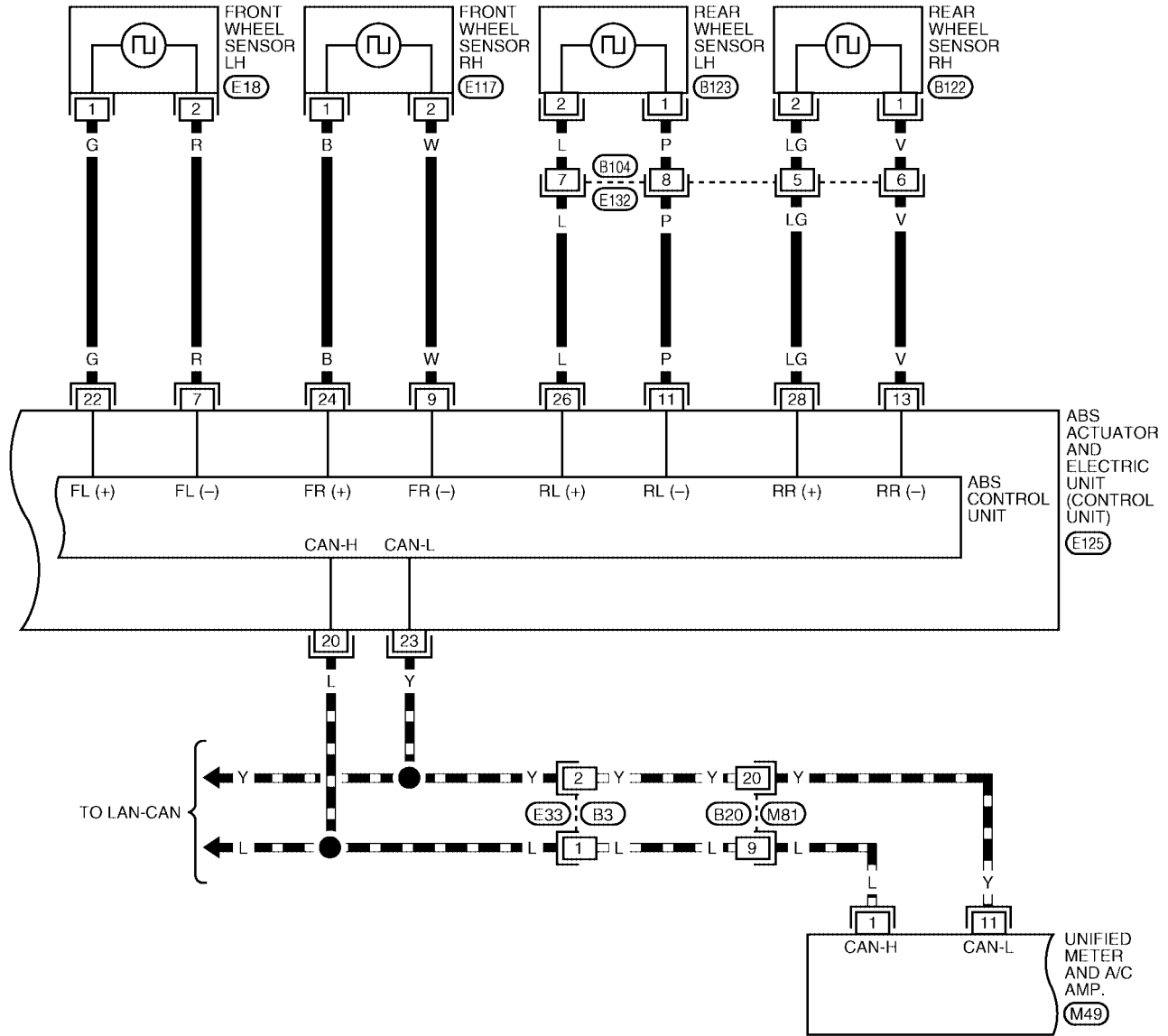

WFWA0019E

# TROUBLE DIAGNOSIS

[ABS]

BRC-ABS-04

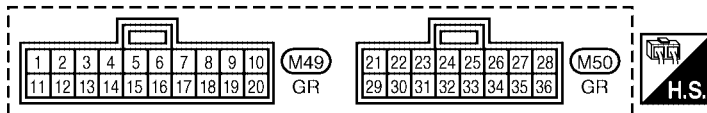
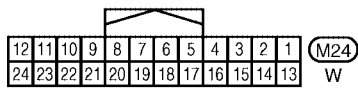
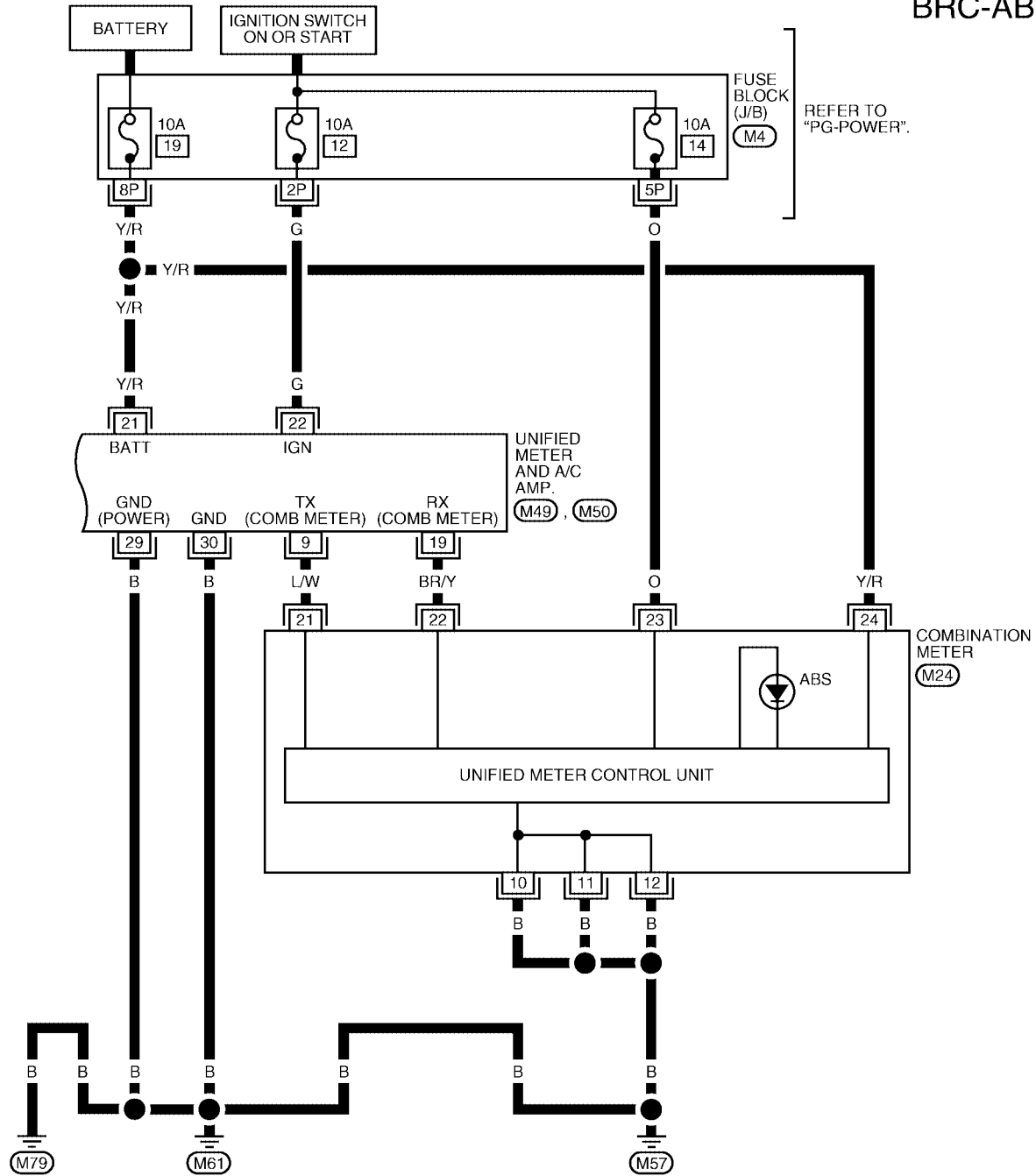

Refer to the following.  
 (M4) - FUSE BLOCK - JUNCTION BOX (J/B)

WFWA0020E

**Basic Inspection****BRAKE FLUID LEVEL, FLUID LEAK, AND BRAKE PAD INSPECTION**

1. Check fluid level in the brake fluid reservoir. If fluid level is low, add fluid.
2. Check the brake piping and around the ABS actuator and electric unit (control unit) for leaks. If there is leaking or seeping fluid, check the following items.
  - If ABS actuator and electric unit (control unit) connection is loose, tighten the piping to the specified torque and recheck for leaks.
  - If there is damage to the connection flare nut or ABS actuator and electric unit (control unit) screw, replace the damaged part and recheck for leaks.
  - When there is fluid leaking or seeping from a fluid connection, use a clean cloth to wipe off the fluid and recheck for leaks. If fluid is still seeping out, replace the damaged part. If the fluid is leaking at the ABS actuator and electric unit (control unit), replace the ABS actuator and electric unit (control unit) assembly.

**CAUTION:**

**The ABS actuator and electric unit (control unit) cannot be disassembled and must be replaced as an assembly.**

3. Check the brake pads for excessive wear.

**POWER SYSTEM TERMINAL LOOSENESS AND BATTERY INSPECTION**

Make sure the battery positive cable, negative cable and ground connection are not loose. In addition, make sure the battery is sufficiently charged.

**ABS WARNING LAMP INSPECTION**

1. Make sure ABS warning lamp turns on for approximately 1 second when the ignition switch is turned ON. Check CAN communications. If there are no errors with CAN communication system, check combination meter. Refer to [DI-5, "COMBINATION METERS"](#).
2. Make sure the lamp turns off approximately 1 second after the ignition switch is turned ON. If the lamp does not turn off, conduct self-diagnosis.
3. Make sure ABS warning lamp turns off approximately 2 seconds after the engine is started. If ABS warning lamp has not turned off 10 seconds after the engine has been started, conduct self-diagnosis of the ABS actuator and electric unit (control unit).
4. After conducting the self-diagnosis, be sure to erase the error memory. Refer to [BRC-24, "CONSULT-II Function \(ABS\)"](#).

**Warning Lamp and Indicator Timing**

×: ON    -: Lamp OFF

Condition	ABS warning lamp	Remarks
When the ignition switch is OFF	–	–
After the ignition switch is turned ON For approx. 0.5 seconds	×	–
Ignition switch ON Approx. 0.5 seconds later	–	Lamp goes off approx. 2 seconds after the engine start.
ABS malfunction	×	–
	×	When the ABS control unit is malfunctioning (power supply or ground malfunction).

# TROUBLE DIAGNOSIS

[ABS]

EFS002Z9

## Control Unit Input/Output Signal Standard REFERENCE VALUE FROM CONSULT-II

### CAUTION:

The display shows the control unit calculation data, so a normal value might be displayed even in the event the output circuit (harness) is open or short circuited.

Monitor item	Display content	Data monitor		Note: Error inspection checklist
		Condition	Reference value in normal operation	
SLCT LVR POSI	PNP switch signal ON/OFF condition	A/T shift position = N or P position	ON	<a href="#">BRC-36, "CAN Communication System Inspection"</a>
		A/T shift position = other than N and P positions	OFF	
GEAR	A/T gear position	1:1st gear 2:2nd gear 3:3rd gear 4:4th gear		<a href="#">BRC-36, "CAN Communication System Inspection"</a>
FR RH SENSOR FR LH SENSOR RR RH SENSOR RR LH SENSOR	Wheel speed	Vehicle stopped	0 [km/h (MPH)]	<a href="#">BRC-31, "Wheel Sensor System Inspection"</a>
		Vehicle running (Note 1)	Almost in accordance with speedometer display (within ±10%)	
ACCEL POS SIG	Open/close condition of throttle valve (linked with accelerator pedal).	Accelerator pedal not depressed (ignition switch is ON)	0%	<a href="#">BRC-36, "CAN Communication System Inspection"</a>
		Depress accelerator pedal (ignition switch is ON)	0 to 100%	
ENGINE SPEED	With engine running	With engine stopped	0 rpm	<a href="#">BRC-32, "Engine System Inspection"</a>
		Engine running	Almost in accordance with tachometer display	
BATTERY VOLT	Battery voltage supplied to ABS actuator and electric unit (control unit)	Ignition switch ON	10 to 16V	<a href="#">BRC-35, "ABS Control Unit Power and Ground Systems Inspection"</a>
STOP LAMP SW	Brake pedal operation	Brake pedal depressed	ON	<a href="#">BRC-34, "Stop Lamp Switch System Inspection"</a>
		Brake pedal not depressed	OFF	
ABS WARN LAMP	ABS warning lamp ON condition (Note 2)	ABS warning lamp ON	ON	<a href="#">BRC-40, "ABS Warning Lamp Does Not Come On When Ignition Switch Is Turned On"</a>
		ABS warning lamp OFF	OFF	
MOTOR RELAY	Operation status of motor and motor relay	Ignition switch ON or engine running (ABS not operated)	OFF	<a href="#">BRC-33, "Actuator Motor, Motor Relay, and Circuit Inspection"</a>
		Ignition switch ON or engine running (ABS operated)	ON	
ACTUATOR RLY	Actuator relay operation status	Vehicle stopped (Ignition switch ON)	OFF	<a href="#">BRC-33, "Actuator Motor, Motor Relay, and Circuit Inspection"</a>
		Vehicle stopped (Engine running)	ON	
FR LH IN SOL FR LH OUT SOL FR RH IN SOL FR RH OUT SOL RR RH IN SOL RR RH OUT SOL RR LH IN SOL RR LH OUT SOL	Solenoid valve operation	Actuator (solenoid) is active ("ACTIVE TEST" with CONSULT-II) or actuator relay is inactive (in fail-safe mode).	ON	—
		When actuator (solenoid) is not active and actuator relay is active (ignition switch ON).	OFF	

# TROUBLE DIAGNOSIS

[ABS]

Monitor item	Display content	Data monitor		Note: Error inspection checklist
		Condition	Reference value in normal operation	
FLUID LEV SW	ON/OFF status of brake fluid level switch	When brake fluid level switch ON	ON	<a href="#">DI-41. "WARNING LAMPS"</a>
		When brake fluid level switch OFF	OFF	
ABS FAIL SIG EBD FAIL SIG	Fail signal status	ABS fail EBD fail	OFF	ABS system EBD system

Note 1: Confirm tire pressure is normal.

Note 2: ON/OFF timing of ABS warning lamp

ON: For approximately 1.8 seconds after ignition switch is turned ON, or when a malfunction is detected.

A  
B  
C  
D  
E

**BRC**

G  
H  
I  
J  
K  
L  
M

## CONSULT-II Function (ABS)

CONSULT-II can display each diagnostic item using the diagnostic test modes shown following.

ABS diagnostic mode	Description
WORK SUPPORT	Supports inspection and adjustments. Commands are transmitted to the ABS actuator and electric unit (control unit) for setting the status suitable for required operation, input/output signals are received from the ABS actuator and electric unit (control unit) and received data is displayed.
SELF-DIAG RESULTS	Displays ABS actuator and electric unit (control unit) self-diagnosis results.
DATA MONITOR	Displays ABS actuator and electric unit (control unit) input/output data in real time.
CAN DIAG SUPPORT MNTR	The result of transmit/receive diagnosis of CAN communication can be read.
ACTIVE TEST	Operation of electrical loads can be checked by sending drive signal to them.
FUNCTION TEST	Conducted by CONSULT-II instead of a technician to determine whether each system is "OK" or "NG".
ECU PART NUMBER	ABS actuator and electric unit (control unit) part number can be read.

### CONSULT-II BASIC OPERATION PROCEDURE

1. Turn ignition switch OFF.
2. Connect CONSULT-II and CONSULT-II CONVERTER to the data link connector.

**CAUTION:**

If CONSULT-II is used with no connection of CONSULT-II CONVERTER, malfunctions might be detected in self-diagnosis depending on control unit which carry out CAN communication.

3. Turn ignition switch ON.

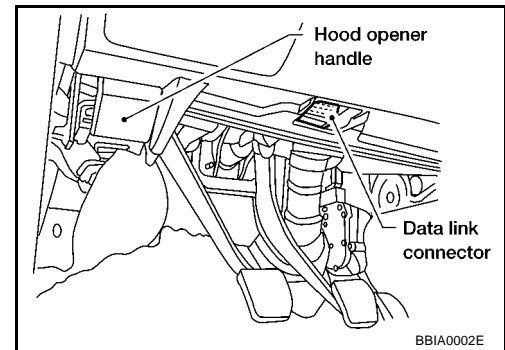

4. Touch "START (NISSAN BASED VHCL)".

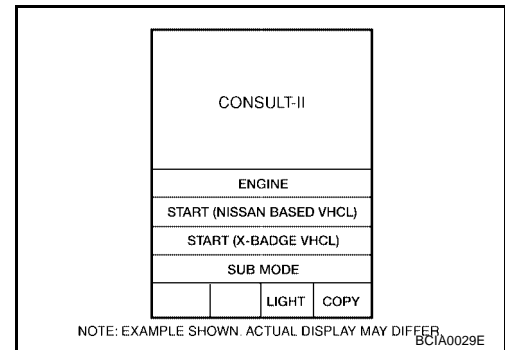

5. Touch "ABS" in the "Select System" screen.  
If "ABS" is not indicated, go to [GI-36, "CONSULT-II Data Link Connector \(DLC\) Circuit"](#).

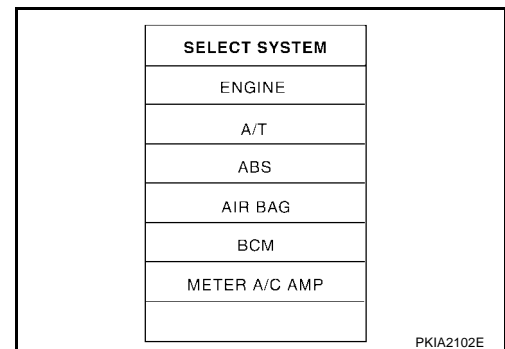

6. Select the required diagnostic location from the "Diagnosis Mode Selection" screen.  
For further information, see the CONSULT-II Operation Manual.



**SELF-DIAGNOSIS****Description**

If an error is detected in the system, the ABS warning lamp will turn on. In this case, perform self-diagnosis as follows:

**Operation Procedure**

1. Turn ignition switch OFF.
2. Connect CONSULT-II and CONSULT-II CONVERTER to the data link connector.

**CAUTION:**

**If CONSULT-II is used with no connection of CONSULT-II CONVERTER, malfunctions might be detected in self-diagnosis depending on control unit which carry out CAN communication.**

3. Turn ignition switch ON.
4. Start engine and drive at approximately 30 km/h (19 MPH) for approximately 1 minute.
5. After stopping the vehicle, with the engine running, touch "START (NISSAN BASED VHCL)", "ABS", "SELF-DIAG RESULTS" in order on the CONSULT-II screen.

**CAUTION:**

**If "START (NISSAN BASED VHCL)" is touched immediately after starting the engine or turning on the ignition switch, "ABS" might not be displayed in the Select System screen. In this case, repeat the operation from step 1.**

6. The self-diagnostic results are displayed. (If necessary, the self-diagnostic results can be printed out by touching "COPY".)
  - When "NO FAILURE" is displayed, check the ABS warning lamp.
7. Conduct the appropriate inspection from the display item list, and repair or replace the malfunctioning component.
8. Start engine and drive at approximately 30 km/h (19 MPH) for approximately 1 minute.

**CAUTION:**

**● When a wheel sensor "short-circuit" is detected, if the vehicle is not driven at 30 km/h (19 MPH) for at least 1 minute, the ABS warning lamp will not turn off even if the malfunction is repaired.**

9. Turn ignition switch OFF to prepare for erasing the memory.
10. Start the engine and touch "START (NISSAN BASED VHCL)", "ABS", "SELF-DIAG RESULTS", "ERASE MEMORY" in order on the CONSULT-II screen to erase the error memory.  
If "ABS" is not indicated, go to [GI-36, "CONSULT-II Data Link Connector \(DLC\) Circuit"](#).

**CAUTION:**

**If the error memory is not erased, re-conduct the operation from step 5.**

11. For the final inspection, drive at approximately 30 km/h (19 MPH) for approximately 1 minute and confirm that the ABS warning lamp are off.

# TROUBLE DIAGNOSIS

[ABS]

## Display Item List

Self-diagnostic item	Malfunction detecting condition	Check system	
FR LH SENSOR 1 [C1104]	Circuit of front LH wheel sensor is open	<a href="#">BRC-31. "Wheel Sensor System Inspection"</a> (Note 1)	
RR RH SENSOR 1 [C1101]	Circuit of rear RH wheel sensor is open		
FR RH SENSOR 1 [C1103]	Circuit of front RH wheel sensor is open		
RR LH SENSOR 1 [C1102]	Circuit of rear LH wheel sensor is open		
FR LH SENSOR 2 [C1108]	Circuit of front LH wheel sensor is shorted, or sensor power voltage is unusual. ABS actuator and electric unit (control unit) cannot identify sensor pulses, because of large gap between wheel sensor and sensor rotor.		
RR RH SENSOR 2 [C1105]	Circuit of rear RH wheel sensor is shorted, or sensor power voltage is unusual. ABS actuator and electric unit (control unit) cannot identify sensor pulses, because of large gap between wheel sensor and sensor rotor.		
FR RH SENSOR 2 [C1107]	Circuit of front RH wheel sensor is shorted, or sensor power voltage is unusual. ABS actuator and electric unit (control unit) cannot identify sensor pulses, because of large gap between wheel sensor and sensor rotor.		
RR LH SENSOR 2 [C1106]	Circuit of rear LH wheel sensor is shorted, or sensor power voltage is unusual. ABS actuator and electric unit (control unit) cannot identify sensor pulses, because of large gap between wheel sensor and sensor rotor.		
STOP LAMP SW 1 [C1116]	Stop lamp switch or circuit malfunction.		<a href="#">BRC-34. "Stop Lamp Switch System Inspection"</a>
FR LH IN ABS SOL [C1120]	Circuit of front LH IN ABS solenoid is open or shorted, or control line is open or shorted to power supply or ground.		—
FR LH OUT ABS SOL [C1121]	Circuit of front LH OUT ABS solenoid is open or shorted, or control line is open or shorted to power supply or ground.		
RR RH IN ABS SOL [C1126]	Circuit of rear RH IN ABS solenoid is open or shorted, or control line is open or shorted to power supply or ground.		
RR RH OUT ABS SOL [C1127]	Circuit of rear RH OUT ABS solenoid is open or shorted, or control line is open or shorted to power supply or ground.		
FR RH IN ABS SOL [C1122]	Circuit of front RH IN ABS solenoid is open or shorted, or control line is open or shorted to power supply or ground.		
FR RH OUT ABS SOL [C1123]	Circuit of front RH OUT ABS solenoid is open or shorted, or control line is open or shorted to power supply or ground.		
RR LH IN ABS SOL [C1124]	Circuit of rear LH IN ABS solenoid is open or shorted, or control line is open or shorted to power supply or ground.		
RR LH OUT ABS SOL [C1125]	Circuit of rear LH OUT ABS solenoid is open or shorted, or control line is open or shorted to power supply or ground.		
PUMP MOTOR (Note 3) [C1111]	During actuator motor operation with ON, when actuator motor turns OFF or when control line for actuator motor relay is open. During actuator motor operation with OFF, when actuator motor turns ON or when control line for relay is shorted to ground.	<a href="#">BRC-33. "Actuator Motor, Motor Relay, and Circuit Inspection"</a>	
BATTERY VOLTAGE [ABNORMAL] [C1109]	ABS actuator and electric unit (control unit) power voltage is too low.	<a href="#">BRC-35. "ABS Control Unit Power and Ground Systems Inspection"</a>	
CONTROLLER FAILURE [C1110]	Internal malfunction of ABS actuator and electric unit (control unit)	<a href="#">BRC-33. "ABS Control Unit Inspection"</a>	

# TROUBLE DIAGNOSIS

[ABS]

Self-diagnostic item	Malfunction detecting condition	Check system
CAN COMM CIRCUIT [U1000]	<ul style="list-style-type: none"> <li>CAN communication line is open or shorted.</li> <li>ABS actuator and electric unit (control unit) internal malfunction</li> <li>Battery voltage for ECM is suddenly interrupted for approximately 0.5 seconds or more.</li> </ul>	<a href="#">BRC-36. "CAN Communication System Inspection"</a> (Note 2)
BR FLUID LEVEL LOW [C1155]	Brake fluid level drops or circuit between ABS actuator and electric unit (control unit) and brake fluid level switch is open or shorted.	<a href="#">DI-41. "WARNING LAMPS"</a>
ENGINE SPEED SIG	Engine speed signal from ECM is abnormal.	<a href="#">BRC-32. "Engine System Inspection"</a>
ENGINE SIGNAL 1 [C1130]	ECM judges the communication between ABS control unit and ECM is abnormal.	<a href="#">BRC-36. "CAN Communication System Inspection"</a>
STOP LAMP SW 2 [C1176]	ASCD brake switch or circuit malfunction.	<a href="#">EC-672. "ASCD BRAKE SWITCH"</a>

Note 1. If wheel sensor 2 for each wheel is indicated, check ABS actuator and electric unit (control unit) power supply voltage in addition to wheel sensor circuit check.

Note 2. If multiple malfunctions are detected including CAN communication line [U1000], perform diagnosis for CAN communication line first.

Note 3: "ACTUATOR RLY" on the CONSULT-II self-diagnosis results indicates the malfunction of the actuator motor relay or circuit.

## DATA MONITOR

### Operation Procedure

- After turning OFF the ignition switch, connect CONSULT-II and the CONVERTER to the data link connector.

**CAUTION:**

If CONSULT-II is used with no connection of CONSULT-II CONVERTER, malfunctions might be detected in self-diagnosis depending on control unit which carry out CAN communication.

- Touch "START (NISSAN BASED VHCL)", "ABS", "DATA MONITOR" in order on the CONSULT-II screen. If "ABS" is not indicated, go to [GI-36. "CONSULT-II Data Link Connector \(DLC\) Circuit"](#).

**CAUTION:**

When "START (NISSAN BASED VHCL)" is touched immediately after starting the engine or turning on the ignition switch, "ABS" might not be displayed in the system selection screen. In this case, repeat the operation from step 2.

- Return to the Monitor Item Selection screen, and touch "C/U INPUT ITEM", "MAIN ITEM" or "ITEM MENU SELECTION". Refer to the following information.
- When "START" is touched, the data monitor screen is displayed.

### Display Item List

Item (Unit)	Data monitor item selection			Remarks
	ECU INPUT SIGNALS	MAIN SIGNALS	SELECTION FROM MENU	
GEAR	×	×	×	Gear position judged by PNP switch signal is displayed.
FR RH SENSOR (km/h, MPH)	×	×	×	Wheel speed calculated by front RH wheel sensor signal is displayed.
FR LH SENSOR (km/h, MPH)	×	×	×	Wheel speed calculated by front LH wheel sensor signal is displayed.
RR RH SENSOR (km/h, MPH)	×	×	×	Wheel speed calculated by rear RH wheel sensor signal is displayed.
RR LH SENSOR (km/h, MPH)	×	×	×	Wheel speed calculated by rear LH wheel sensor signal is displayed.

# TROUBLE DIAGNOSIS

**[ABS]**

Item (Unit)	Data monitor item selection			Remarks
	ECU INPUT SIGNALS	MAIN SIGNALS	SELECTION FROM MENU	
BATTERY VOLT (V)	×	×	×	Voltage supplied to ABS actuator and electric unit (control unit) is displayed.
SLCT LVR POSI	×	×	×	Shift position judged by PNP switch signal.
ACCEL POS SIG (%)	×	-	×	Throttle valve open/close status judged by LAN communication signal is displayed.
ENGINE SPEED (rpm)	×	×	×	Engine speed judged by LAN communication signal is displayed.
STOP LAMP SW (ON/OFF)	×	×	×	Stop lamp switch (ON/OFF) status is displayed.
ABS WARN LAMP (ON/OFF)	-	×	×	ABS warning lamp (ON/OFF) status is displayed.
FR LH IN SOL (ON/OFF)	-	×	×	Front LH IN ABS solenoid (ON/OFF) status is displayed.
FR LH OUT SOL (ON/OFF)	-	×	×	Front LH OUT ABS solenoid (ON/OFF) status is displayed.
RR RH IN SOL (ON/OFF)	-	×	×	Rear RH IN ABS solenoid (ON/OFF) status is displayed.
RR RH OUT SOL (ON/OFF)	-	×	×	Rear RH OUT ABS solenoid (ON/OFF) status is displayed.
FR RH IN SOL (ON/OFF)	-	×	×	Front RH IN ABS solenoid (ON/OFF) status is displayed.
FR RH OUT SOL (ON/OFF)	-	×	×	Front RH OUT ABS solenoid (ON/OFF) status is displayed.
RR LH IN SOL (ON/OFF)	-	×	×	Rear LH IN ABS solenoid (ON/OFF) status is displayed.
RR LH OUT SOL (ON/OFF)	-	×	×	Rear LH OUT ABS solenoid (ON/OFF) status is displayed.
MOTOR RELAY (ON/OFF)	-	×	×	ABS motor relay signal (ON/OFF) status is displayed.
ACTUATOR RLY (ON/OFF)	-	×	×	ABS actuator relay signal (ON/OFF) status is displayed.
ABS FAIL SIG (ON/OFF)	-	-	×	ABS fail signal (ON/OFF) status is displayed.
EBD FAIL SIG (ON/OFF)	-	-	×	EBD fail signal (ON/OFF) status is displayed.
FLUID LEV SW (ON/OFF)	×	-	×	Brake fluid level switch (ON/OFF) status is displayed.
EBD SIGNAL (ON/OFF)	-	-	×	EBD operation (ON/OFF) status is displayed.
ABS SIGNAL (ON/OFF)	-	-	×	ABS operation (ON/OFF) status is displayed.
TRQ MAP S/C	-	-	×	S/C is selected for engine torque map
TRQ MAP N/A	-	-	×	N/A is selected for engine

×: Applicable

-: Not applicable

## ACTIVE TEST

**CAUTION:**

- Do not perform active test while driving.
- Make sure to completely bleed air from the brake system.
- The ABS and brake (EBD) warning lamps turn on during the active test.

### Operation Procedure

1. Connect the CONSULT-II and CONVERTER to the data link connector and start the engine.

**CAUTION:**

If CONSULT-II is used with no connection of CONSULT-II CONVERTER, malfunctions might be detected in self-diagnosis depending on control unit which carry out CAN communication.

2. Touch "START (NISSAN BASED VHCL)" on the display screen.
3. Touch "ABS".  
If "ABS" is not indicated, go to [GI-36, "CONSULT-II Data Link Connector \(DLC\) Circuit"](#).
4. Touch "ACTIVE TEST".
5. The test item selection screen is displayed.
6. Touch necessary test item.

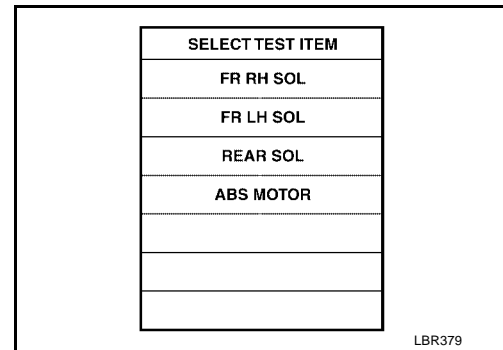

7. With the "MAIN ITEM" display shown in reverse, touch "START".
8. The Active Test screen will be displayed, so conduct the following test.

### Solenoid Valve Operation Chart

Operation		ABS solenoid valve			ABS solenoid valve (ACT)		
		UP	KEEP	DOWN	UP	ACTUA-TOR UP	ACTUA-TOR KEEP
FR RH SOL FR RH ABS SOLE- NOID (ACT)	FR RH IN SOL	OFF	ON	ON	OFF	OFF	OFF
	FR RH OUT SOL	OFF	OFF	ON*	OFF	OFF	OFF
FR LH SOL FR LH ABS SOLE- NOID (ACT)	FR LH IN SOL	OFF	ON	ON	OFF	OFF	OFF
	FR LH OUT SOL	OFF	OFF	ON*	OFF	OFF	OFF
RR RH SOL RR RH ABS SOLE- NOID (ACT)	RR RH IN SOL	OFF	ON	ON	OFF	OFF	OFF
	RR RH OUT SOL	OFF	OFF	ON*	OFF	OFF	OFF
RR LH SOL RR LH ABS SOLE- NOID (ACT)	RR LH IN SOL	OFF	ON	ON	OFF	OFF	OFF
	RR LH OUT SOL	OFF	OFF	ON*	OFF	OFF	OFF
REAR SOL	RR RH IN SOL	OFF	ON	ON	OFF	OFF	OFF
	RR RH OUT SOL	OFF	OFF	ON*	OFF	OFF	OFF
	RR LH IN SOL	OFF	ON	ON	OFF	OFF	OFF
	RR LH OUT SOL	OFF	OFF	ON*	OFF	OFF	OFF

\*: ON for 1 to 2 seconds after the touch, and then OFF

**NOTE:**

- If active test is performed with brake pedal depressed, pedal stroke may change. This is normal.
- "TEST IS STOPPED" is displayed approximately 10 seconds after operation starts.
- After "TEST IS STOPPED" is displayed, to perform test again, repeat Step 6.

## ABS Motor

Touch "ON" and "OFF" on the screen. Check that ABS motor relay operates as shown in table below.

Operation	ON	OFF
ABS actuator relay	ON	ON
ABS motor relay	ON	OFF

**NOTE:**

- If active test is performed with brake pedal depressed, pedal stroke may change. This is normal.
- "TEST IS STOPPED" is displayed approximately 10 seconds after operation starts.

ACTIVE TEST

ABS MOTOR	OFF
MONITOR	
MOTOR RELAY	OFF
ACTUATOR RLY	ON
ON	
MODE	BACK
LIGHT	COPY

SFIA0593E

**TROUBLE DIAGNOSIS FOR SELF-DIAGNOSTIC ITEMS**

PFP:00000

**Wheel Sensor System Inspection**

EFS00309

## INSPECTION PROCEDURE

**1. CONNECTOR INSPECTION**

Disconnect the ABS actuator and electric unit connector E125 and wheel sensor of malfunctioning code. Check the terminals for deformation, disconnection, looseness or damage.

OK or NG

OK &gt;&gt; GO TO 2.

NG &gt;&gt; Repair or replace as necessary.

**2. CHECK WHEEL SENSOR OUTPUT SIGNAL**

1. Disconnect connectors from wheel sensor of malfunction code No.
2. Connect ABS active wheel sensor tester (J-45741) to wheel sensor using appropriate adapter.
3. Turn on the ABS active wheel sensor tester power switch.

**NOTE:**

The green POWER indicator should illuminate. If the POWER indicator does not illuminate, replace the battery in the ABS active wheel sensor tester before proceeding.

4. Spin the wheel of the vehicle by hand and observe the red SENSOR indicator on the ABS active wheel sensor tester. The red SENSOR indicator should flash on and off to indicate an output signal.

**NOTE:**

If the red SENSOR indicator illuminates but does not flash, reverse the polarity of the tester leads and retest.

Does the ABS active wheel sensor tester detect a signal?

Yes &gt;&gt; GO TO 3.

No &gt;&gt; GO TO 6.

**3. CHECK TIRES**

Check for inflation pressure, wear and size of each tire.

Are tire pressure and size correct and is tire wear within specifications?

Yes &gt;&gt; GO TO 4.

No &gt;&gt; Adjust tire pressure or replace tire(s).

**4. CHECK WHEEL BEARINGS**

Check wheel bearing axial end play. Refer to [FAX-5, "FRONT WHEEL BEARING"](#) or [RAX-5, "REAR WHEEL BEARING"](#).

OK or NG

OK &gt;&gt; GO TO 5.

NG >> Repair as necessary. Refer to [FAX-5, "FRONT WHEEL BEARING"](#) or [RAX-5, "REAR WHEEL BEARING"](#).

**5. CHECK SENSOR ROTORS**

Check sensor rotors for teeth damage.

OK or NG

OK &gt;&gt; GO TO 6.

NG >> Replace sensor rotor. Refer to [BRC-137, "Removal and Installation"](#).

**6. CHECK WIRING HARNESS FOR SHORT CIRCUIT**

1. Disconnect ABS actuator and electric unit (control unit) connector and wheel sensor connector of malfunction code No.
2. Check resistance between harness connector terminal and ground.

**Continuity should not exist.**

OK or NG

- OK >> GO TO 7.
- NG >> Repair the circuit.

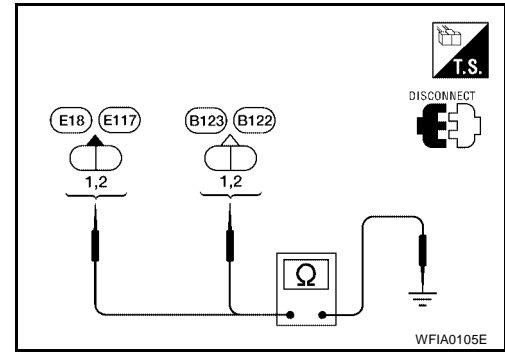

**7. CHECK WIRING HARNESS FOR OPEN CIRCUIT**

1. Disconnect ABS actuator and electric unit (control unit) connector and wheel sensor connector of malfunction code No.
2. Check continuity between both wiring harness ends.

Sensor	ABS actuator and electric unit (control unit)		Wheel sensor		Continuity
	Connector - terminal	Wire color	Connector - terminal	Wire color	
Front LH	E125 - 22	G	E18 - 1	G	Yes
	E125 - 7	R	E18 - 2	R	
Front RH	E125 - 24	B	E117 - 1	B	
	E125 - 9	W	E117 - 2	W	
Rear LH	E125 - 11	P	B123 - 1	P	
	E125 - 26	L	B123 - 2	L	
Rear RH	E125 - 13	V	B122 - 1	V	
	E125 - 28	LG	B122 - 2	LG	

**Continuity should exist.**

OK or NG

- OK >> Replace the ABS actuator and electric unit (control unit). Refer to [BRC-85, "Removal and Installation"](#).
- NG >> Repair the circuit.

**Engine System Inspection**

EFS0030A

**INSPECTION PROCEDURE**

**1. SELF-DIAGNOSIS RESULT CHECK**

Check self-diagnosis results.

Self-diagnosis results
ENGINE SIGNAL 1

Is the above displayed in the self-diagnosis display items?

- Yes >> GO TO 2.
- No >> **INSPECTION END.**



**2. ENGINE SYSTEM INSPECTION**

1. Perform ECM self-diagnosis and repair as necessary.
2. Perform ABS actuator and electric unit (control unit) self-diagnosis again.

OK or NG

- OK >> **INSPECTION END.**
- NG >> Repair as necessary.

**ABS Control Unit Inspection**

EFS0030B

INSPECTION PROCEDURE

**1. SELF-DIAGNOSIS RESULT CHECK**

Check self-diagnosis results.

Self-diagnosis results
CONTROLLER FAILURE

Is the above displayed in the self-diagnosis display items?

- Yes >> Replace ABS actuator and electric unit. Refer to [BRC-85, "Removal and Installation"](#) .
- No >> **INSPECTION END.**

BRC

**Actuator Motor, Motor Relay, and Circuit Inspection**

EFS0030C

INSPECTION PROCEDURE

**1. CHECKING SELF-DIAGNOSIS RESULTS**

Check self-diagnosis results.

Self-diagnosis results
CONSULT-II display items
PUMP MOTOR

Does "PUMP MOTOR" appear in self-diagnosis results display?

- Yes >> GO TO 2.
- No >> **INSPECTION END.**

**2. CONNECTOR INSPECTION**

Disconnect the ABS actuator and electric unit connector E125.  
Check the terminals for deformation, disconnection, looseness or damage.

OK or NG

- OK >> GO TO 3.
- NG >> Repair or replace as necessary.

**3. CHECKING ABS MOTOR AND MOTOR RELAY POWER SYSTEM**

1. Disconnect ABS actuator and electric unit (control unit) connector.
2. Check voltage between ABS actuator and electric unit (control unit) connector E125 and body ground.

ABS actuator and electric unit (control unit) connector E125	Body ground	Measured value (Approx.)
1 (R/B)	—	12V

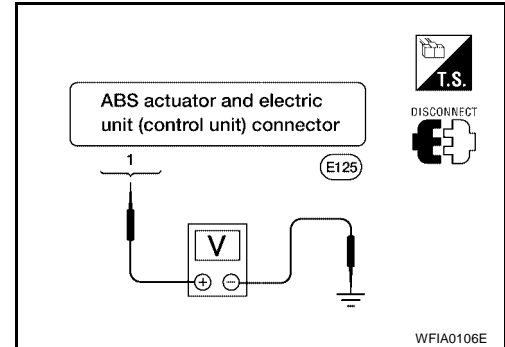

3. Check resistance between ABS actuator and electric unit (control unit) connector E125 and ground.

ABS actuator and electric unit (control unit) connector E125	Body ground	Measured value (Approx.)
30 (B)	—	0Ω

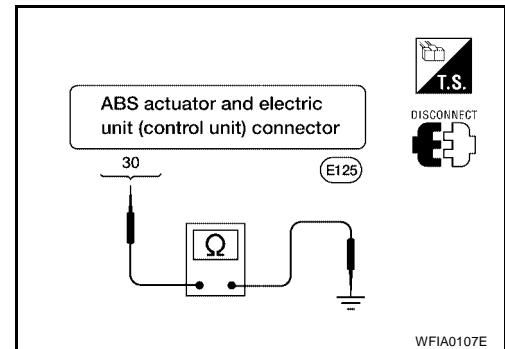

OK or NG

- OK >> Perform self-diagnosis again. If the same result appears, replace ABS actuator and electric unit (control unit). Refer to [BRC-85, "Removal and Installation"](#).
- NG >> Repair the circuit.

**Stop Lamp Switch System Inspection**

EFS0030E

INSPECTION PROCEDURE

**1. SELF-DIAGNOSIS RESULT CHECK**

Check self-diagnosis results.

Self-diagnosis results
STOP LAMP SW

Is the above displayed in the self-diagnosis display items?

- Yes >> GO TO 2.
- No >> **INSPECTION END.**

**2. CONNECTOR INSPECTION**

1. Turn off the ignition switch and disconnect the ABS actuator and electric unit connector E125 and stop lamp switch connector E38.
2. Check the terminals for deformation, disconnection, looseness or damage.

OK or NG

- OK >> GO TO 3.
- NG >> Repair or replace as necessary.

**3. STOP LAMP SWITCH INSPECTION**

Turn the ignition switch on and check the voltage between the ABS actuator and electric unit connector E125 terminal 17 (R/G) and ground.

**17 (R/G) - Ground**

**Brake pedal depressed : Battery voltage (approx. 12V)**

**Brake pedal not depressed : Approx. 0V**

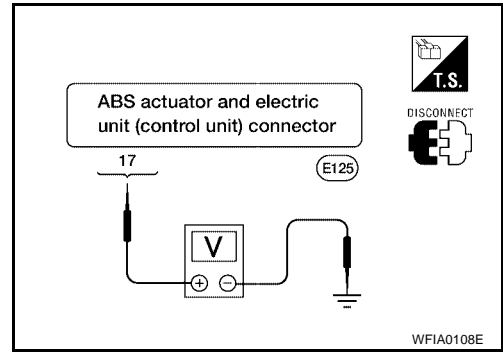

OK or NG

OK >> Connect the connectors and conduct ABS actuator and electric unit self-diagnosis.

NG >> Repair the circuit.

**ABS Control Unit Power and Ground Systems Inspection**

EFS0030F

INSPECTION PROCEDURE

**1. SELF-DIAGNOSIS RESULT CHECK**

Check self-diagnosis results.

Self-diagnosis results
BATTERY VOLTAGE

Is the above displayed in the self-diagnosis item?

Yes >> GO TO 2.

No >> **INSPECTION END.**

**2. CONNECTOR INSPECTION**

1. Turn the ignition switch off and disconnect the ABS actuator and electric unit connector E125.
2. Check the terminals for deformation, disconnection, looseness or damage.

OK or NG

OK >> GO TO 3.

NG >> Repair or replace as necessary.

**3. ABS CONTROL UNIT POWER AND GROUND CIRCUIT INSPECTION**

1. Disconnect ABS actuator and electric unit connector E125.
2. Turn the ignition switch on.
3. Measure the voltage and continuity between the ABS actuator and electric unit connector E125 and the ground.

Signal name	ABS actuator and electric unit (control unit) connector E125	Ground	Measured value
Power supply	29 (GR)	—	Battery voltage (Approx. 12V)
Ground	16 (B)		Continuity should exist.
	30 (B)		

OK or NG

OK >> Check the battery for loose terminals, low voltage, etc. Repair as necessary.

NG >> Repair the circuit.

---

## CAN Communication System Inspection

### INSPECTION PROCEDURE

#### 1. CHECK CONNECTOR

---

1. Turn ignition switch OFF, disconnect the ABS actuator and electric unit (control unit) connector, and check the terminal for deformation, disconnection, looseness, and so on. If there is a malfunction, repair or replace the terminal.
2. Reconnect connector to perform self-diagnosis.

Is "CAN COMM CIRCUIT" displayed in the self-diagnosis display items?

- Yes >> Print out the self-diagnosis results, and refer to [LAN-8, "CAN COMMUNICATION"](#) .
- No >> Connector terminal connection is loose, damaged, open, or shorted.

**TROUBLE DIAGNOSES FOR SYMPTOMS****ABS Works Frequently****1. CHECK WARNING LAMP ACTIVATION**

Make sure warning lamp remains off while driving.

OK or NG

OK >> GO TO 2.

NG >> Carry out self-diagnosis. Refer to [BRC-25, "SELF-DIAGNOSIS"](#).

**2. CHECK WHEEL SENSORS**

Check the following.

- Wheel sensor mounting for looseness
- Wheel sensors for physical damage
- Wheel sensor connectors for terminal damage or loose connections

OK or NG

OK >> GO TO 3.

NG >> Repair as necessary.

**3. CHECK FRONT AXLE**

Check front and rear axles for excessive looseness. Refer to [FAX-5, "FRONT WHEEL BEARING"](#) or [RAX-5, "REAR WHEEL BEARING"](#).

OK or NG

OK >> GO TO 4.

NG >> Repair as necessary.

**4. CHECK BRAKE FLUID PRESSURE**

Check brake fluid pressure distribution.

Refer to [BR-36, "Inspection"](#).

Is brake fluid pressure distribution normal?

Yes >> **INSPECTION END.**

No >> Perform Basic Inspection. Refer to [BRC-21, "Basic Inspection"](#).

A

B

C

D

E

BRC

G

H

I

J

K

L

M

## Unexpected Pedal Action

### 1. CHECK WARNING LAMP ACTIVATION

Make sure warning lamp remains off while driving.

OK or NG

OK >> GO TO 2.

NG >> Carry out self-diagnosis. Refer to [BRC-25, "SELF-DIAGNOSIS"](#).

### 2. CHECK BRAKE PEDAL STROKE

Check brake pedal stroke.

Is pedal stroke excessive?

Yes >> Perform Basic Inspection. Refer to [BRC-21, "Basic Inspection"](#).

No >> GO TO 3.

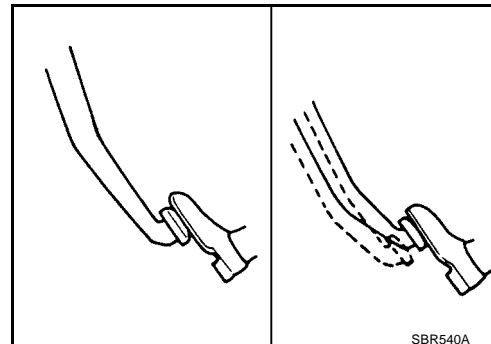

### 3. CHECK CONNECTOR AND BRAKING PERFORMANCE

1. Disconnect ABS actuator and electric unit (control unit) connector.

2. Check brake effectiveness.

OK or NG

OK >> GO TO 4.

NG >> Perform Basic Inspection. Refer to [BRC-21, "Basic Inspection"](#).

### 4. CHECK WHEEL SENSORS

Check the following.

- Wheel sensor mounting for looseness
- Wheel sensors for physical damage
- Wheel sensor connectors for terminal damage or loose connections

OK or NG

OK >> Check ABS actuator and electric unit (control unit) pin terminals for damage and the connection of harness connector. Reconnect ABS actuator and electric unit (control unit) harness connector. Then retest.

NG >> Repair as necessary.

**Long Stopping Distance**

EFS002Z0

**1. CHECK BASE BRAKING SYSTEM PERFORMANCE**

1. Disable ABS by disconnecting ABS actuator and electric unit (control unit) connector.
2. Drive vehicle and check to see if stopping distance is still long.

**OK or NG**

- OK >> Go to [BRC-37, "ABS Works Frequently"](#) .
- NG >> Perform Basic Inspection. Refer to [BRC-21, "Basic Inspection"](#) .

**NOTE:**

Stopping distance may be longer than vehicles without ABS when road condition is slippery.

**ABS Does Not Work**

EFS002ZR

**CAUTION:**

The ABS does not operate when the vehicle speed is 10 km/h (6 MPH) or less.

**1. CHECK WARNING LAMP ACTIVATION**

Turn ignition switch ON and check for warning lamp activation.

- Warning lamp should activate for approximately 1 second after turning the ignition switch ON.

**OK or NG**

- OK >> Carry out self-diagnosis. Refer to [BRC-25, "SELF-DIAGNOSIS"](#) .
- NG >> Go to [BRC-40, "ABS Warning Lamp Does Not Come On When Ignition Switch Is Turned On"](#) .

**Pedal Vibration or ABS Operation Noise**

EFS002ZS

**NOTE:**

During ABS activation, pedal vibration may be felt and a noise may be heard. This is normal and does not indicate a malfunction.

**1. CHECK SYMPTOM**

1. Apply brake.
2. Start engine.

Does the symptom occur only when engine is started?

- Yes >> Carry out self-diagnosis. Refer to [BRC-25, "SELF-DIAGNOSIS"](#) .
- No >> GO TO 2.

**2. RECHECK SYMPTOM**

Does the symptom occur only when electrical equipment switches (such as headlamp) are turned on?

- Yes >> Check for radio, antenna or related wiring that is routed too close to the ABS actuator and electric unit (control unit) and reroute as necessary.
- No >> Go to [BRC-37, "ABS Works Frequently"](#) .

**ABS Warning Lamp Does Not Come On When Ignition Switch Is Turned On** EFS002ZT**1. CHECK ABS ACTUATOR AND ELECTRIC UNIT (CONTROL UNIT) FUSES**

Check 30A fusible link **g** and 30A fusible link **h** for ABS actuator and electric unit (control unit). For fusible link layout, refer to [PG-3, "POWER SUPPLY ROUTING CIRCUIT"](#).

OK or NG

OK >> GO TO 2.

NG >> If fusible link is blown, be sure to eliminate cause of problem before replacing.

**2. CHECK ABS ACTUATOR AND ELECTRIC UNIT (CONTROL UNIT) POWER SUPPLY CIRCUITS**

1. Disconnect ABS actuator and electric unit (control unit) connector.
2. Check voltage between ABS actuator connector terminal 1 and ground and terminal 15 and ground.

Does battery voltage exist?

Yes >> GO TO 3.

No >> Repair harness or connectors between fusible link and ABS actuator and electric unit (control unit).

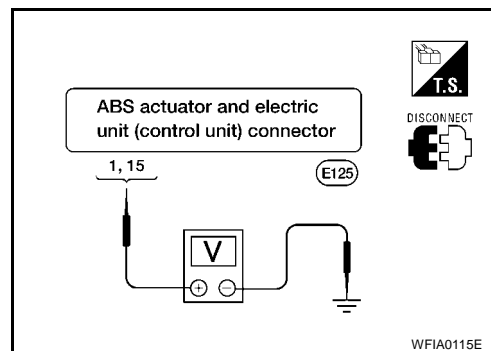
**3. CHECK ABS ACTUATOR AND ELECTRIC UNIT (CONTROL UNIT) GROUND CIRCUIT**

Check continuity between ABS actuator connector terminal 16 and ground and terminal 30 and ground.

Does continuity exist?

Yes >> Replace ABS actuator and electric unit (control unit).

No >> Repair harness or connectors between ABS actuator and electric unit (control unit) and ground.

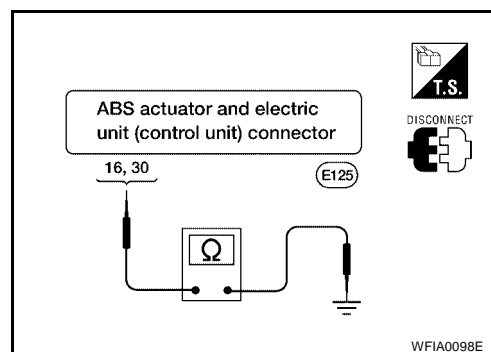
**ABS Warning Lamp Stays On When Ignition Switch Is Turned On** EFS002ZU**1. CARRY OUT SELF-DIAGNOSIS**

Carry out self-diagnosis. Refer to [BRC-25, "SELF-DIAGNOSIS"](#).

Are malfunctions detected in self-diagnosis?

Yes >> Refer to [BRC-26, "Display Item List"](#).

No >> Refer to [DI-41, "WARNING LAMPS"](#).



## WHEEL SENSORS

### Removal and Installation

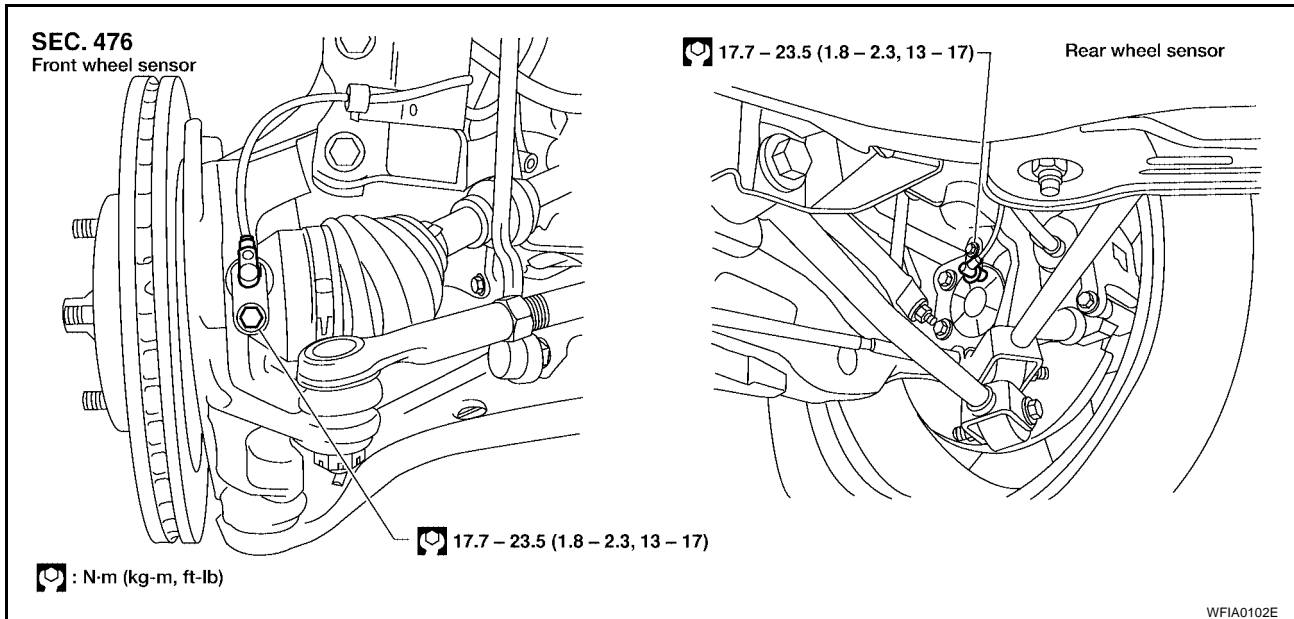

**CAUTION:**

**Be careful not to damage sensor edge and sensor rotor teeth.**

When removing the front or rear wheel hub assembly, first remove the ABS wheel sensor from the assembly. Failure to do so may result in damage to the sensor wires making the sensor inoperative.

**CAUTION:**

**Pull out the sensor being careful to turn it as little as possible. Do not pull on the sensor harness. Installation should be performed while paying attention to the following, and then tighten fasteners to the specified torque.**

- Before installing wheel sensor, make sure no foreign materials (such as iron fragments) are adhered to the pick-up part of the sensor, to the inside of the sensor mounting hole or on the rotor mounting surface.

A  
B  
C  
D  
E  
BRC  
G  
H  
I  
J  
K  
L  
M

## SENSOR ROTOR

### Removal and Installation

#### NOTE:

The rear wheel sensor rotor is built into the rear wheel hub. For removal and installation procedure, refer to [RAX-6, "Removal and Installation"](#).

#### REMOVAL

1. Remove the front wheel hub. Refer to [FAX-6, "Removal and Installation"](#).
2. Remove the sensor rotor using suitable puller.

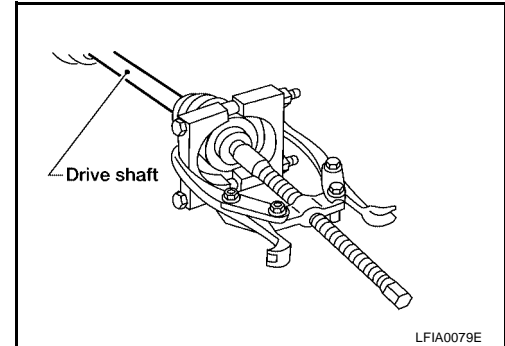

#### INSTALLATION

Install the sensor rotor using a hammer and a wooden block.

- Always replace sensor rotor with new one.

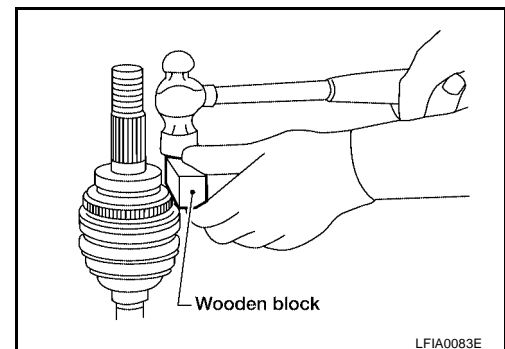

## ACTUATOR AND ELECTRIC UNIT (ASSEMBLY)

PFP:47660

### Removal and Installation

EFS0020R

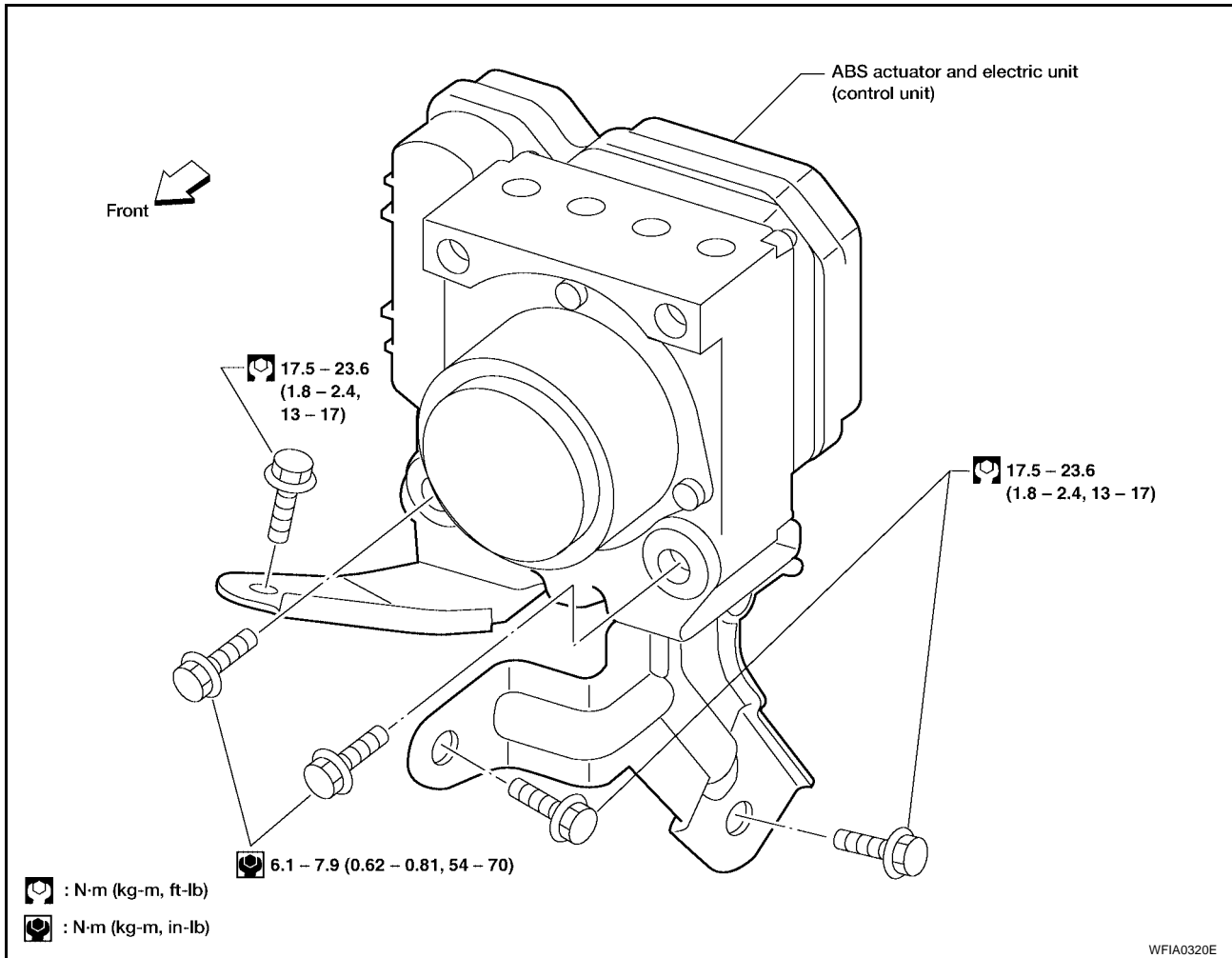

### REMOVAL

1. Disconnect battery cable.
2. Remove windshield wiper and linkage assembly. Refer to [WW-26, "REMOVAL"](#).
3. Drain brake fluid. Refer to [BR-8, "Changing Brake Fluid"](#).
4. Discharge the A/C refrigerant. Refer to [ATC-116, "HFC-134a \(R-134a\) Service Procedure"](#).
5. Disconnect and remove high-pressure and low-pressure A/C pipes to allow access to ABS actuator and electric unit (control unit). Refer to [ATC-118, "Components"](#).
6. Disconnect harness connectors from ABS actuator and electric unit (control unit).
7. Disconnect brake pipes.
8. Remove fasteners for ABS actuator and electric unit (control unit) and remove from vehicle.

### INSTALLATION

#### CAUTION:

**After installation of ABS actuator and electric unit (control unit), refill brake fluid. Then bleed air from system. Refer to [BR-8, "Bleeding Brake System"](#).**

1. Position ABS actuator and electric unit (control unit) in vehicle.
2. Connect brake pipes and fasteners temporarily.
3. Tighten fasteners and brake pipes.
4. Connect ABS actuator and electric unit (control unit) harness connectors.
5. Install and connect high-pressure and low-pressure A/C pipes. Refer to [ATC-118, "Components"](#).
6. Install windshield wiper and linkage assembly. Refer to [WW-27, "INSTALLATION"](#).

A  
B  
C  
D  
E  
BRC  
G  
H  
I  
J  
K

## ACTUATOR AND ELECTRIC UNIT (ASSEMBLY)

[ABS]

---

7. Reconnect battery cable.
8. Evacuate and recharge the A/C system. Refer to [ATC-116, "HFC-134a \(R-134a\) Service Procedure"](#) .

**PRECAUTIONS**

PFP:00001

**Precautions for Supplemental Restraint System (SRS) “AIR BAG” and “SEAT BELT PRE-TENSIONER”**

EFS002V9

The Supplemental Restraint System such as “AIR BAG” and “SEAT BELT PRE-TENSIONER”, used along with a front seat belt, helps to reduce the risk or severity of injury to the driver and front passenger for certain types of collision. Information necessary to service the system safely is included in the SRS and SB section of this Service Manual.

**WARNING:**

- To avoid rendering the SRS inoperative, which could increase the risk of personal injury or death in the event of a collision which would result in air bag inflation, all maintenance must be performed by an authorized NISSAN/INFINITI dealer.
- Improper maintenance, including incorrect removal and installation of the SRS, can lead to personal injury caused by unintentional activation of the system. For removal of Spiral Cable and Air Bag Module, see the SRS section.
- Do not use electrical test equipment on any circuit related to the SRS unless instructed to in this Service Manual. SRS wiring harnesses can be identified by yellow and/or orange harnesses or harness connectors.

**Precautions for Brake System**

EFS002VA

**CAUTION:**

- Recommended fluid is brake fluid “DOT 3”.
- Never reuse drained brake fluid.
- Be careful not to splash brake fluid on painted areas; it may cause paint damage. If brake fluid is splashed on painted areas, wash it away with water immediately.
- To clean or wash all parts of master cylinder and disc brake caliper, use clean brake fluid.
- Never use mineral oils such as gasoline or kerosene. They will ruin rubber parts of the hydraulic system.
- Use flare nut wrench when removing and installing brake tube.
- If a brake fluid leak is found, the part must be disassembled without fail. Then it has to be replaced with a new one if a defect exists.
- Turn the ignition switch OFF and remove the connector of the ABS actuator control unit or the battery terminal before performing the work.
- Always torque brake lines when installing.
- Burnish the brake contact surfaces after refinishing or replacing rotors, after replacing pads, or if a soft pedal occurs at very low mileage.

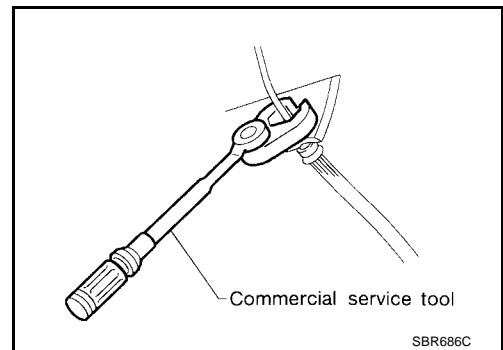

Refer to [BR-28, "Brake Burnishing"](#) (front disc brakes) or [BR-35, "Brake Burnishing"](#) (rear disc brakes).

**WARNING:**

- Clean brake pads and shoes with a waste cloth, then wipe with a dust collector.

**Precautions When Using CONSULT-II**

EFS0031P

When connecting CONSULT-II to data link connector, connect them through CONSULT-II CONVERTER.

**CAUTION:**

If CONSULT-II is used with no connection of CONSULT-II CONVERTER, malfunctions might be detected in self-diagnosis depending on control unit which carry out CAN communication.

**CHECK POINTS FOR USING CONSULT-II**

1. Has CONSULT-II been used without connecting CONSULT-II CONVERTER on this vehicle?
  - If YES, GO TO 2.
  - If NO, GO TO 5.

A  
B  
C  
D  
E  
BRC  
G  
H  
I  
J  
K  
L  
M

# PRECAUTIONS

[TCS/ABS]

2. Is there any indication other than indications relating to CAN communication system in the self-diagnosis results?
  - If YES, GO TO 3.
  - If NO, GO TO 4.
3. Based on self-diagnosis results unrelated to CAN communication, carry out the inspection.
4. Malfunctions may be detected in self-diagnosis depending on control units carrying out CAN communication. Therefore, erase the self-diagnosis results.
5. Diagnose CAN communication system. Refer to [LAN-8, "CAN COMMUNICATION"](#).

## Precautions for Brake Control

EFS002VB

- During ABS operation, the brake pedal may vibrate lightly and a mechanical noise may be heard. This is normal.
- Just after starting vehicle, the brake pedal may vibrate or a motor operating noise may be heard from engine compartment. This is a normal status of operation check.
- Stopping distance may be longer than that of vehicles without ABS when vehicle drives on rough, gravel, or snow-covered (fresh, deep snow) roads.
- When an error is indicated by ABS or another warning lamp, collect all necessary information from customer (what symptoms are present under what conditions) and check for simple causes before starting diagnosis. Besides electrical system inspection, check booster operation, brake fluid level, and fluid leaks.
- If incorrect tire sizes or types are installed on the vehicle or brake pads are not Genuine NISSAN parts, stopping distance or steering stability may deteriorate.
- If there is a radio, antenna or related wiring near control module, ABS function may have a malfunction or error.
- If aftermarket parts (car stereo, CD player, etc.) have been installed, check for incidents such as harness pinches, open circuits or improper wiring.

## Precautions for CAN System

EFS002VC

- Do not apply voltage of 7.0V or higher to terminal to be measured.
- Maximum open terminal voltage of tester in use must be less than 7.0V.
- Before checking harnesses, turn ignition switch OFF and disconnect battery negative cable.
- Area to be repaired must be soldered and wrapped with tape. Make sure that fraying of twisted wire is within 110 mm (4.33 in).

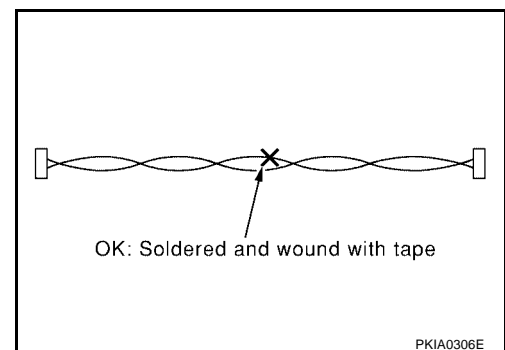

- Do not make a bypass connection to repaired area. (If the circuit is bypassed, characteristics of twisted wire will be lost.)

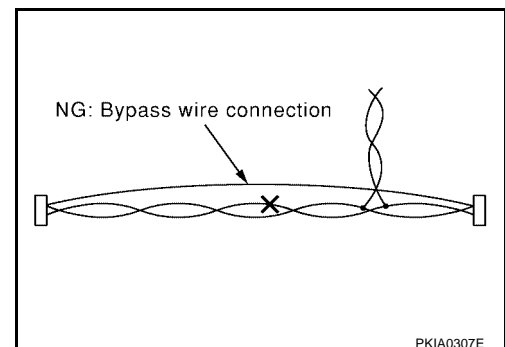

### Wiring Diagrams and Trouble Diagnosis

EFS002VD

When you read wiring diagrams, refer to the following:

- [GI-12, "How to Read Wiring Diagrams"](#)
- [PG-3, "POWER SUPPLY ROUTING CIRCUIT"](#)

When you perform trouble diagnosis, refer to the following:

- [GI-10, "HOW TO FOLLOW TEST GROUPS IN TROUBLE DIAGNOSES"](#)
- [GI-25, "How to Perform Efficient Diagnosis for an Electrical Incident"](#)

A

B

C

D

E

**BRC**

G

H

I

J

K

L

M

# PREPARATION

[TCS/ABS]

## PREPARATION

PFP:00002

### Special Service Tool

EFS002VM

The actual shapes of Kent-Moore tools may differ from those of special service tools illustrated here.

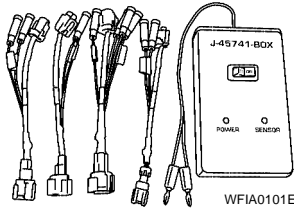
Tool number (Kent-Moore No.) Tool name	Description
<p>(J-45741) ABS active wheel sensor tester</p>  <p style="text-align: right;">WFIA0101E</p>	<p>Checking operation of ABS active wheel sensor</p>

### Commercial Service Tools

EFS002VN

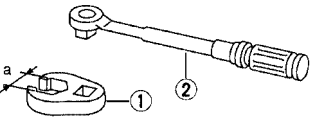
Tool name	Description
<p>1. Flare nut crowfoot a: 10mm (0.39 in)/12mm (0.47 in) 2. Torque wrench</p>  <p style="text-align: right;">S-NT360</p>	<p>Removing and installing brake piping</p>



SYSTEM DESCRIPTION

System Diagram

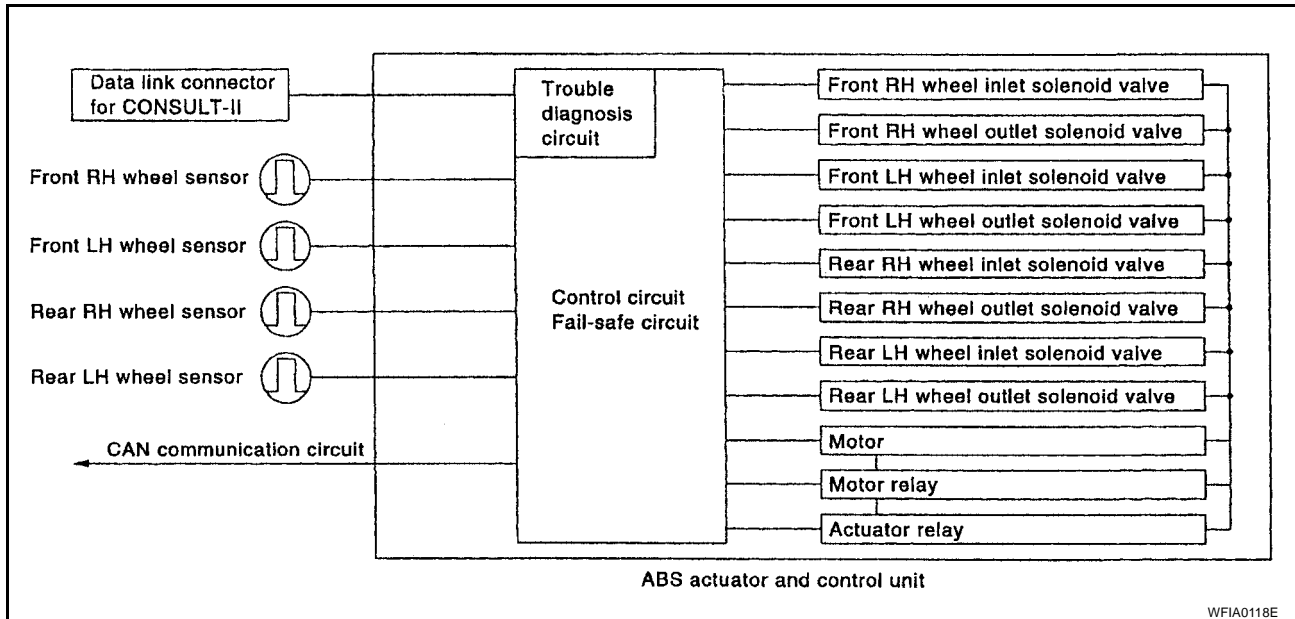

WFIA0118E

ABS Function

EFS002VP

- The Anti-Lock Brake System detects wheel revolution while braking and improves handling stability during sudden braking by electrically preventing wheel lockup. Maneuverability is also improved for avoiding obstacles.
- If the electrical system malfunctions, the Fail-Safe function is activated, the ABS becomes inoperative and the ABS warning lamp turns on.
- The electrical system can be diagnosed using CONSULT-II.
- During ABS operation, the brake pedal may vibrate lightly and a mechanical noise may be heard. This is normal.
- Just after starting the vehicle, the brake pedal may vibrate or a motor operating noise may be heard from engine compartment. This is a normal status of operation check.
- Stopping distance may be longer than that of vehicles without ABS when vehicle drives on rough, gravel, or snow-covered (fresh, deep snow) roads.

EBD Function

EFS002VQ

- Electronic Brake Distribution is a function that detects subtle slippages between the front and rear wheels during braking, and it improves handling stability by electronically controlling the brake fluid pressure which results in reduced rear wheel slippage.
- If the electrical system malfunctions, the Fail-Safe function is activated, the EBD and ABS become inoperative, and the ABS warning lamp and BRAKE warning lamp are turned on.
- The electrical system can be diagnosed using CONSULT-II.
- During EBD operation, the brake pedal may vibrate lightly and a mechanical noise may be heard. This is normal.
- Just after starting the vehicle, the brake pedal may vibrate or a motor operating noise may be heard from engine compartment. This is a normal status of operation check.
- Stopping distance may be longer than that of vehicles without EBD when vehicle drives on rough, gravel, or snow-covered (fresh, deep snow) roads.

TCS Function

EFS002VR

- Spinning of the drive wheels is detected by the ABS/TCS control unit using inputs from the wheel speed sensors. If wheel spin occurs, the drive wheel right and left brake fluid pressure control and engine fuel cut are conducted while the throttle value is restricted to reduce the engine torque and decrease the amount of wheel spin. In addition, the throttle opening is controlled to achieve the optimum engine torque.

A  
B  
C  
D  
E  
BRC

G

H

I

J

K

L

M

# SYSTEM DESCRIPTION

[TCS/ABS]

- Depending on road condition, the vehicle may have a sluggish feel. This is normal, because optimum traction has the highest priority during TCS operation.
- TCS may be activated during sudden vehicle acceleration, wide open throttle acceleration, sudden transmission shifts or when the vehicle is driven on a road with a varying surface friction coefficient.
- The SLIP indicator lamp flashes to inform the driver of TCS operation.

## Wheel Sensors

EFS002VY

The front sensor units consist of a gear-shaped sensor rotor and a sensor element. The element contains a magnet around which a coil is wound. The front wheel sensors are installed on the front of the wheel knuckles. As the wheel rotates, the sensor generates a square-wave signal. The frequency increases as the wheel speed increases.

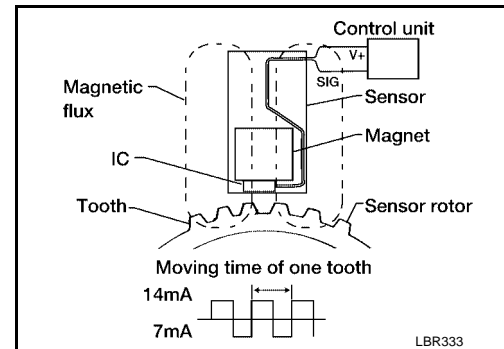

The rear sensor units consist of wheel hubs with a series of internal magnets and a sensor element. The rear wheel sensors are installed on the inner side of the wheel knuckles. As the wheel rotates, the sensor generates a square-wave signal. The frequency increases as the wheel speed increases.

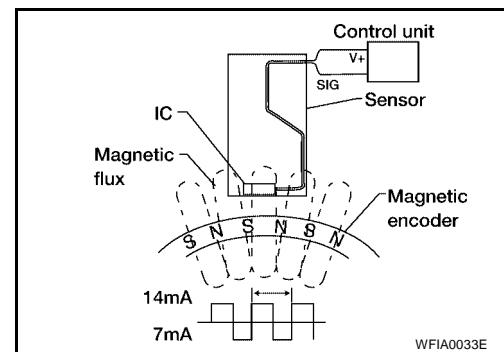

## Fail-Safe Function

EFS002VT

### CAUTION:

If the Fail-Safe function is activated, perform the Self Diagnosis for ABS/TCS system.

### ABS/EBD SYSTEM

In case of an electrical malfunction with the ABS, the ABS warning lamp and SLIP indicator lamp will turn on. In case of an electrical malfunction with the EBD system, the BRAKE warning lamp, ABS warning lamp and SLIP indicator lamp will turn on.

The system will revert to one of the following conditions of the Fail-Safe function.

1. For ABS malfunction, only the EBD is operative and the condition of the vehicle is the same condition of vehicles without ABS/TCS system.
2. For EBD malfunction, the EBD and ABS become inoperative, and the condition of the vehicle is the same as the condition of vehicles without ABS/TCS or EBD system.

### TCS SYSTEM

In case of TCS system malfunction, the SLIP indicator lamp is turned on and the condition of the vehicle is the same as the condition of vehicles without TCS system. In case of an electrical malfunction with the TCS system, the ABS control continues to operate normally without TCS control.

Hydraulic Circuit Diagram

EFS002VU

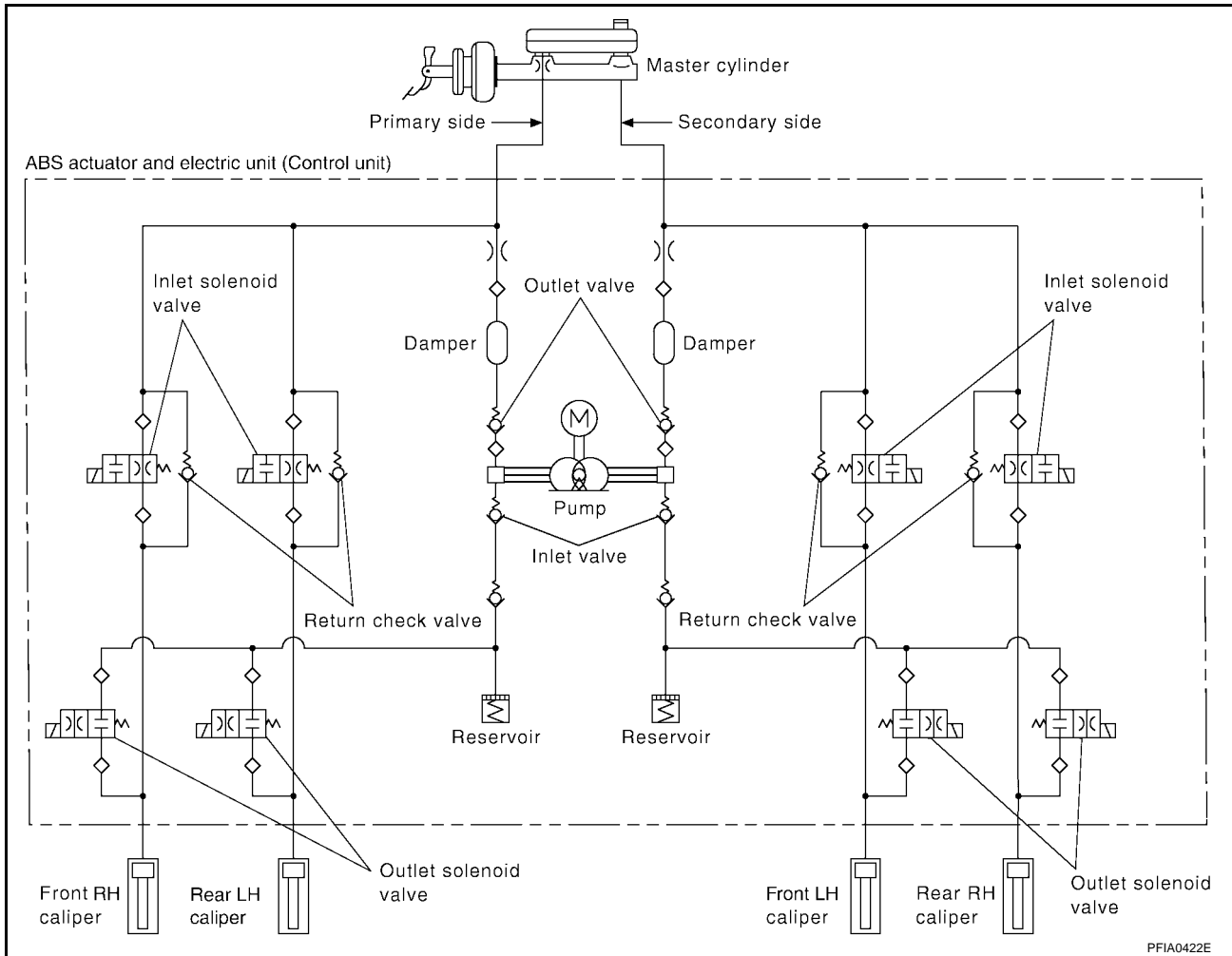

A  
B  
C  
D  
E  
BRC  
G  
H  
I  
J  
K  
L  
M

---

**CAN COMMUNICATION**

PF2:23710

**System Description**

EFS00314

Refer to [LAN-8, "CAN COMMUNICATION"](#) .

**TROUBLE DIAGNOSIS**

**How to Perform Trouble Diagnoses for Quick and Accurate Repair**

**INTRODUCTION**

The ABS/TCS system has an electronic control unit to control major functions. The control unit accepts input signals from sensors and controls actuator operation. It is also important to check for conventional problems such as air leaks in the booster or lines, lack of brake fluid, or other problems with the brake system.

It is much more difficult to diagnose a problem that occurs intermittently rather than continuously. Most intermittent problems are caused by poor electrical connections or faulty wiring. In this case, careful checking of suspicious circuits may help prevent the replacement of good parts.

A visual check only may not find the cause of the problem, so a road test should be performed.

Before undertaking actual checks, take just a few minutes to talk with a customer who approaches with an ABS/TCS complaint. The customer is a very good source of information on such problems, especially intermittent ones. Through the talks with the customer, find out what symptoms are present and under what conditions they occur. Start your diagnosis by looking for "conventional" problems first. This is one of the best ways to troubleshoot brake problems on an ABS/TCS equipped vehicle. Also check related Service Bulletins for information.

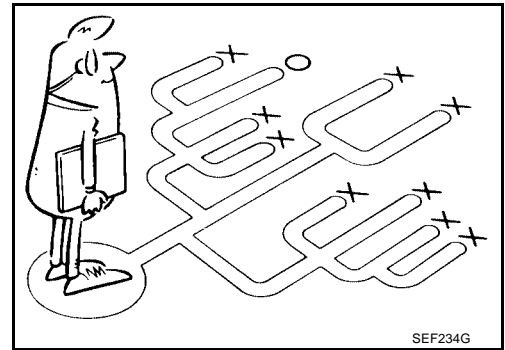
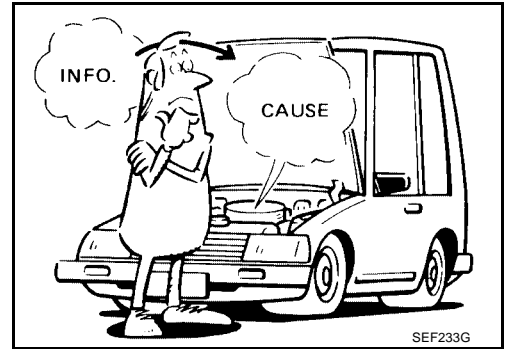

A  
B  
C  
D  
E  
BRC  
G  
H  
I  
J  
K  
L  
M

# TROUBLE DIAGNOSIS

[TCS/ABS]

## WORK FLOW

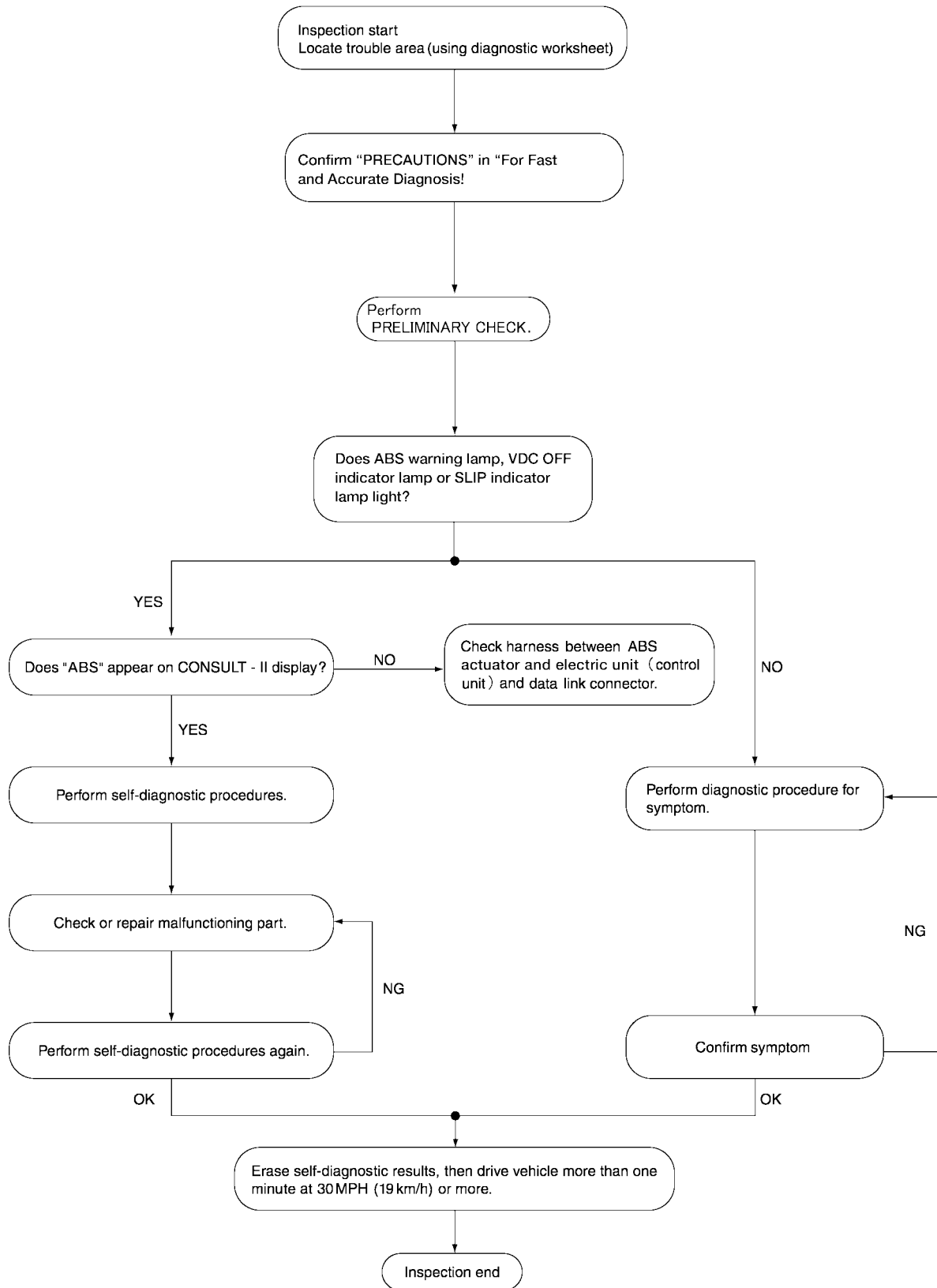

WFIA0130E

# TROUBLE DIAGNOSIS

[TCS/ABS]

## CLARIFY CONCERN

- A customer's description of a vehicle concern may vary depending on the individual. It is important to clarify the customer's concern.
- Ask the customer about what symptoms are present under what conditions. Use this information to reproduce the symptom while driving.
- It is also important to use the diagnosis sheet to understand what type of trouble the customer is having.

**KEY POINTS**

**WHAT** ..... Vehicle model  
**WHEN** ..... Date, Frequencies  
**WHERE** ..... Road conditions  
**HOW** ..... Operating conditions,  
 Weather conditions,  
 Symptoms

SBR339B

## EXAMPLE OF DIAGNOSIS SHEET

Customer name	Model & Year	VIN	
Engine #	Trans.	Mileage	
Incident Date	Manuf. Date	In Service Date	
Symptoms	<input type="checkbox"/> Noise and vibration (from engine compartment)	<input type="checkbox"/> ABS warning lamp activates	<input type="checkbox"/> Pedal operation
	<input type="checkbox"/> Noise and vibration (from axle)	<input type="checkbox"/> SLIP warning lamp activates	<input type="checkbox"/> Large stroke pedal operation
	<input type="checkbox"/> TCS does not work (drive wheels slip when accelerating)	<input type="checkbox"/> ABS does not work (wheels slip when braking)	<input type="checkbox"/> Firm pedal
	<input type="checkbox"/> Lack of sense of acceleration		
Engine conditions	<input type="checkbox"/> When starting <input type="checkbox"/> After starting		
Road conditions	<input type="checkbox"/> Low friction road ( <input type="checkbox"/> Snow <input type="checkbox"/> Gravel <input type="checkbox"/> Other ) <input type="checkbox"/> Bumps/potholes		
Driving conditions	<input type="checkbox"/> Full-acceleration <input type="checkbox"/> High speed cornering <input type="checkbox"/> Vehicle speed: Greater than 10 km/h (6 MPH) <input type="checkbox"/> Vehicle speed: 10 km/h (6 MPH) or less <input type="checkbox"/> Vehicle is stopped		
Applying brake conditions	<input type="checkbox"/> Suddenly <input type="checkbox"/> Gradually		
Other conditions	<input type="checkbox"/> Operation of electrical equipment <input type="checkbox"/> Shift change <input type="checkbox"/> Other descriptions		

WFIA0097E

A  
B  
C  
D  
E  
**BRC**  
G  
H  
I  
J  
K  
L  
M

### Component Parts and Harness Connector Location

EFS002YB

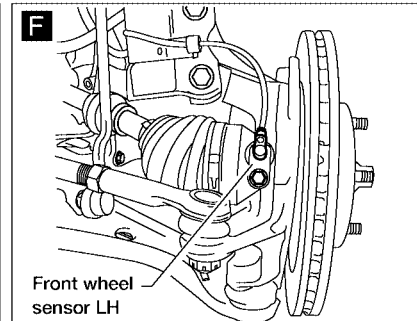
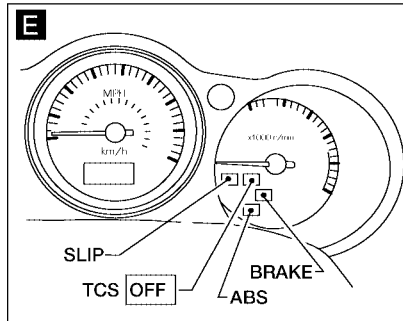
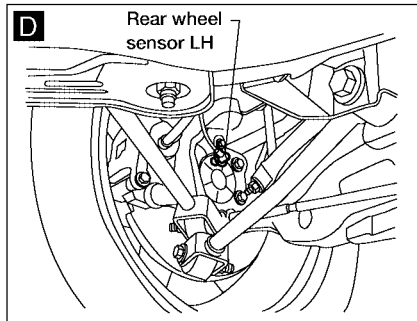
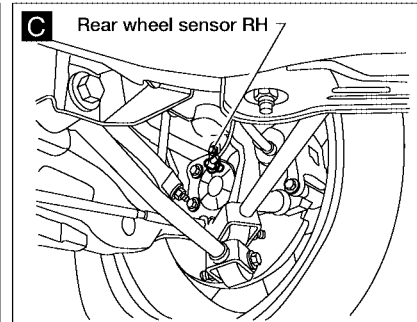
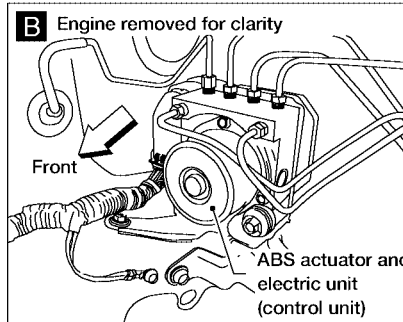
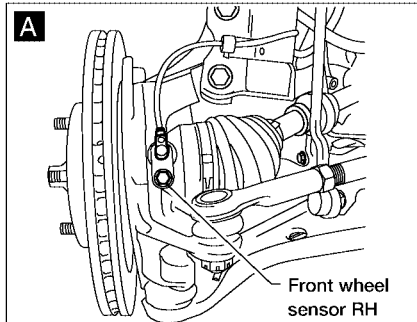
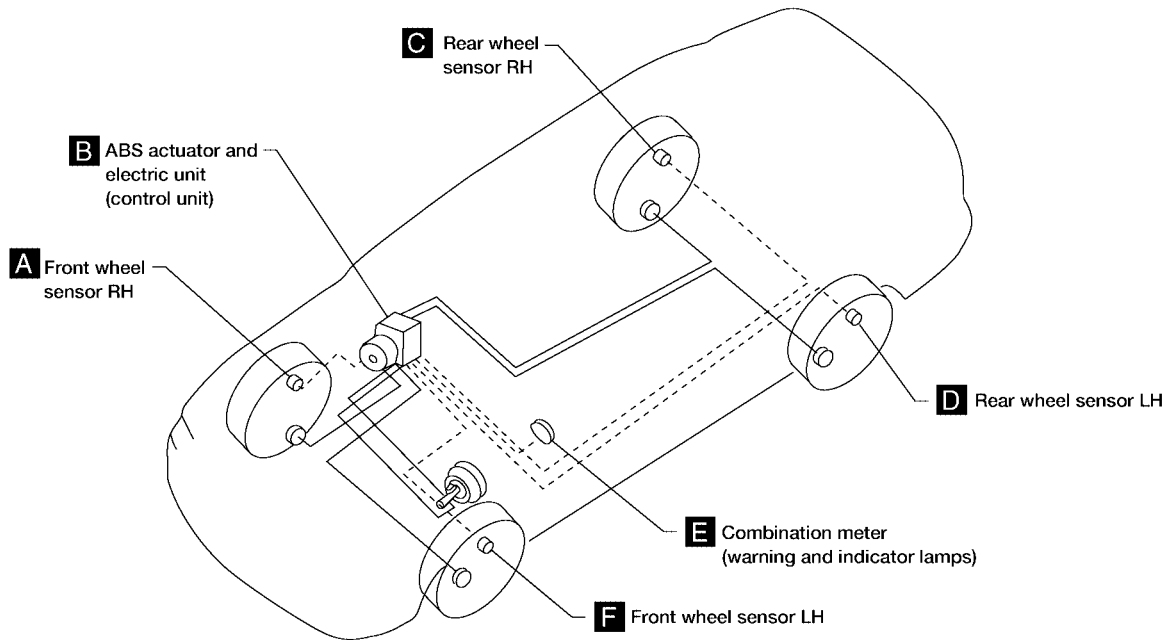

WFIA0117E



Schematic

EFS002YC

A  
B  
C  
D  
E  
BRC  
G  
H  
I  
J  
K  
L  
M

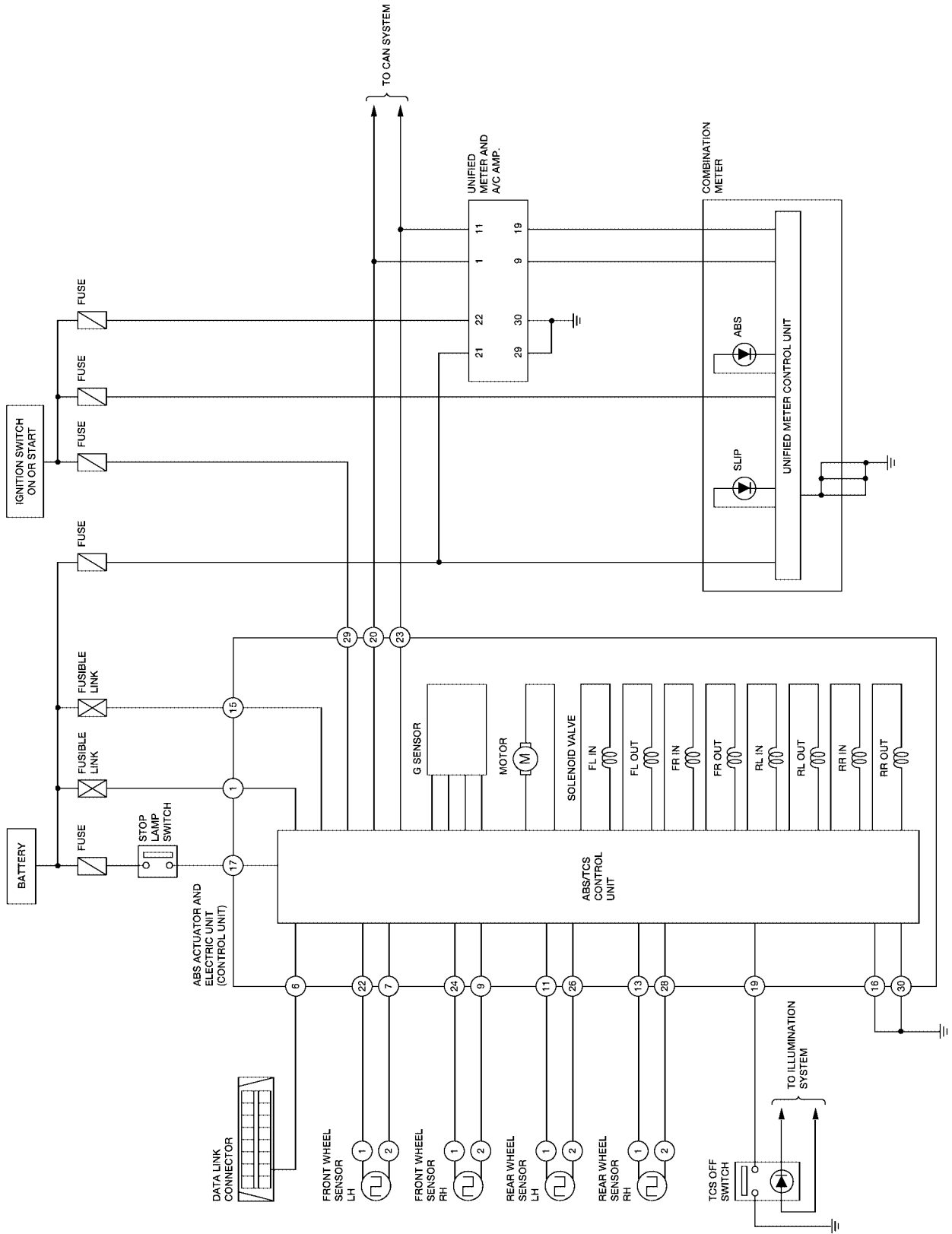

WFWA0022E

# TROUBLE DIAGNOSIS

[TCS/ABS]

## Wiring Diagram — TCS —

EFS002YD

BRC-TCS-01

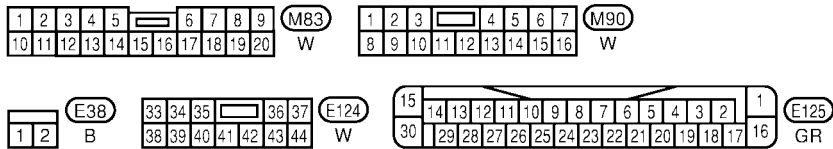
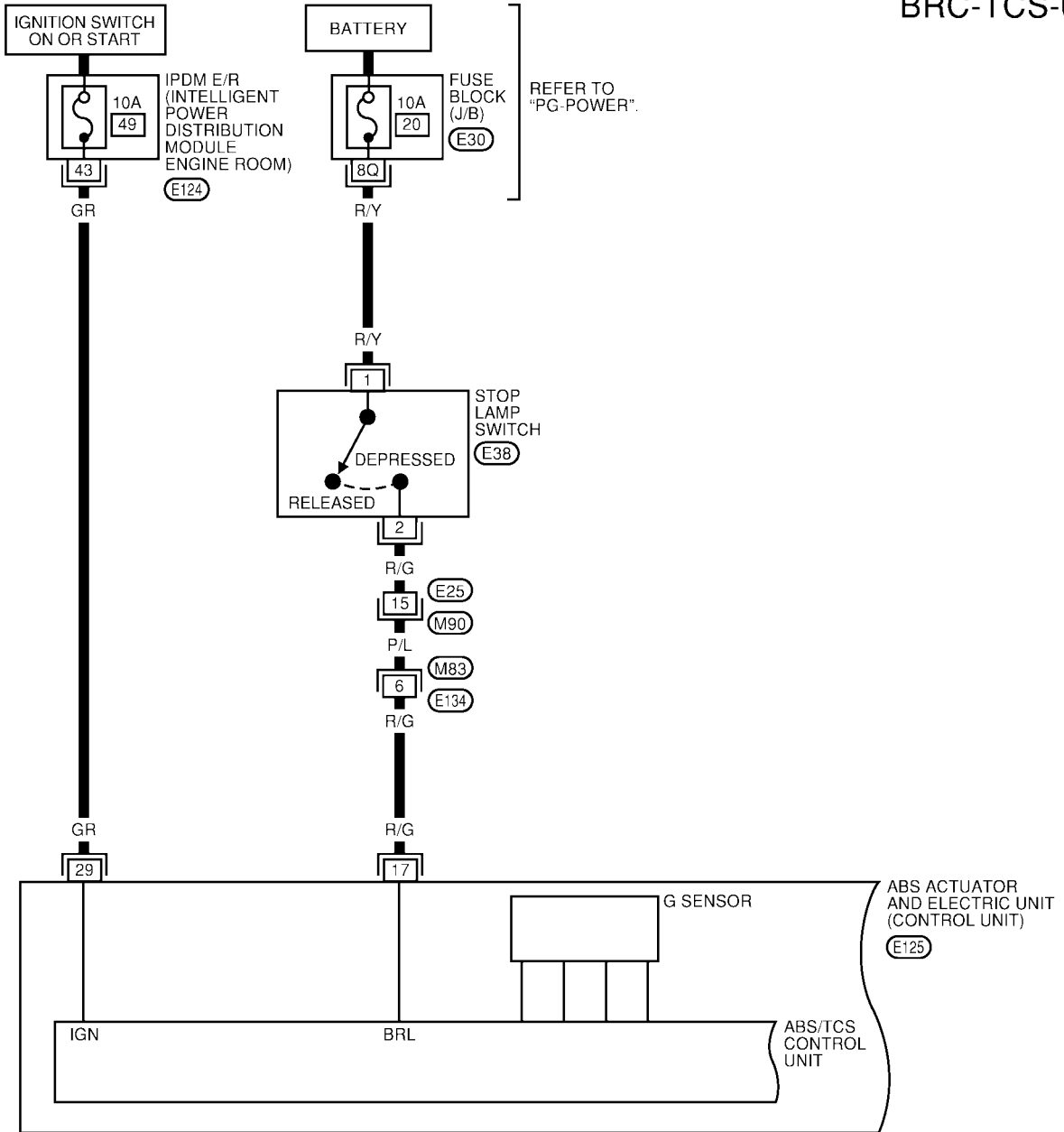

REFER TO THE FOLLOWING.  
 (E30) - FUSE BLOCK -  
 JUNCTION BOX (J/B)

WFWA0023E

# TROUBLE DIAGNOSIS

[TCS/ABS]

BRC-TCS-02

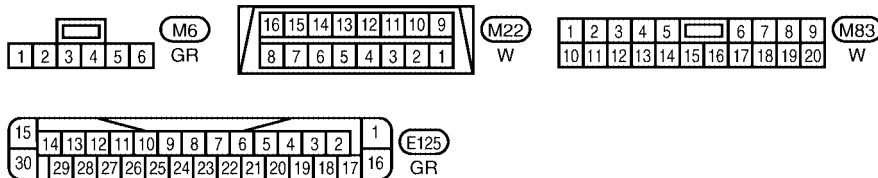
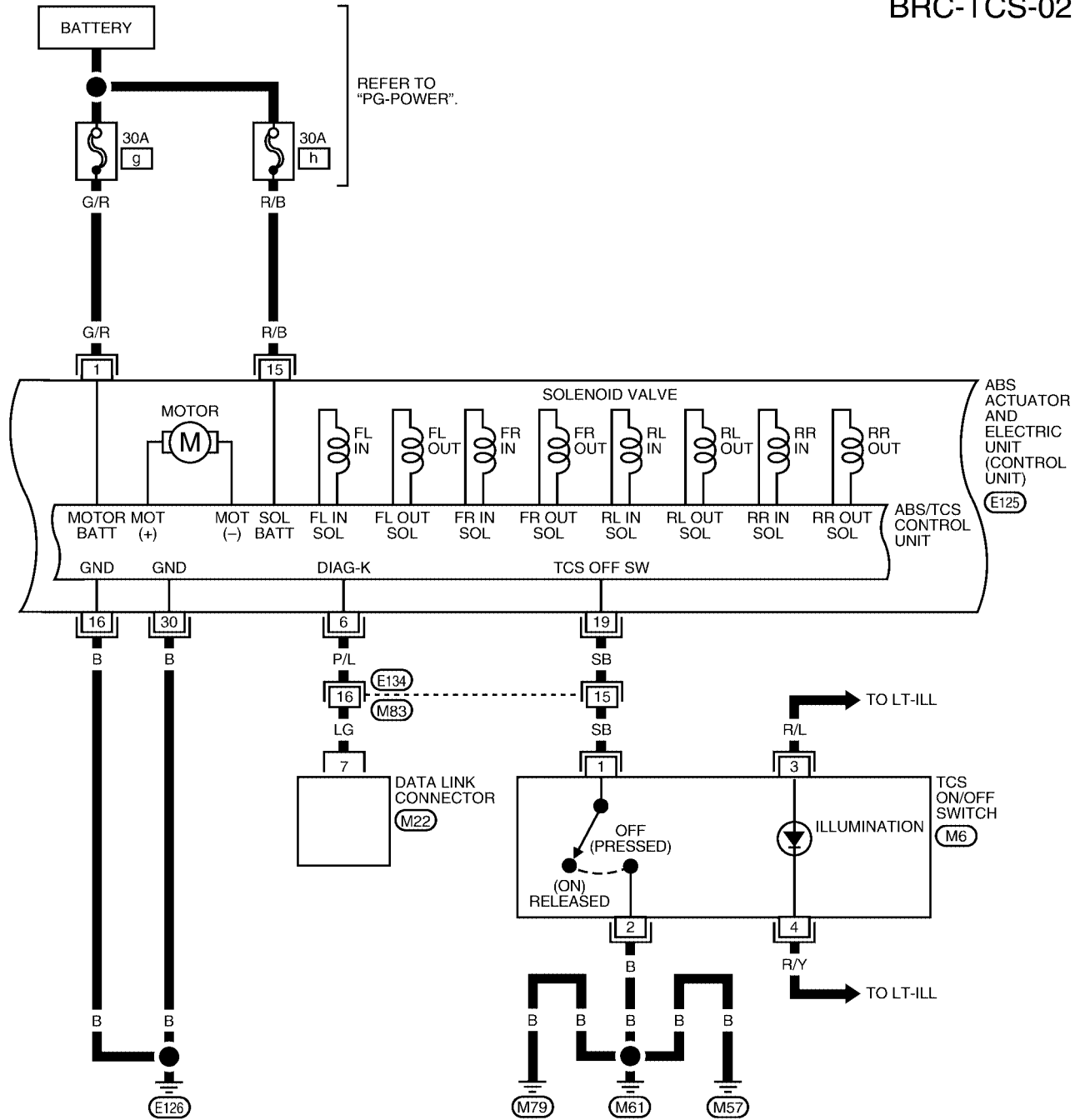

WFWA0064E

# TROUBLE DIAGNOSIS

[TCS/ABS]

BRC-TCS-03

— : DATA LINE

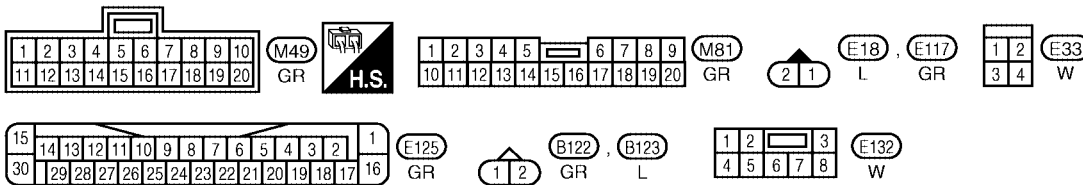
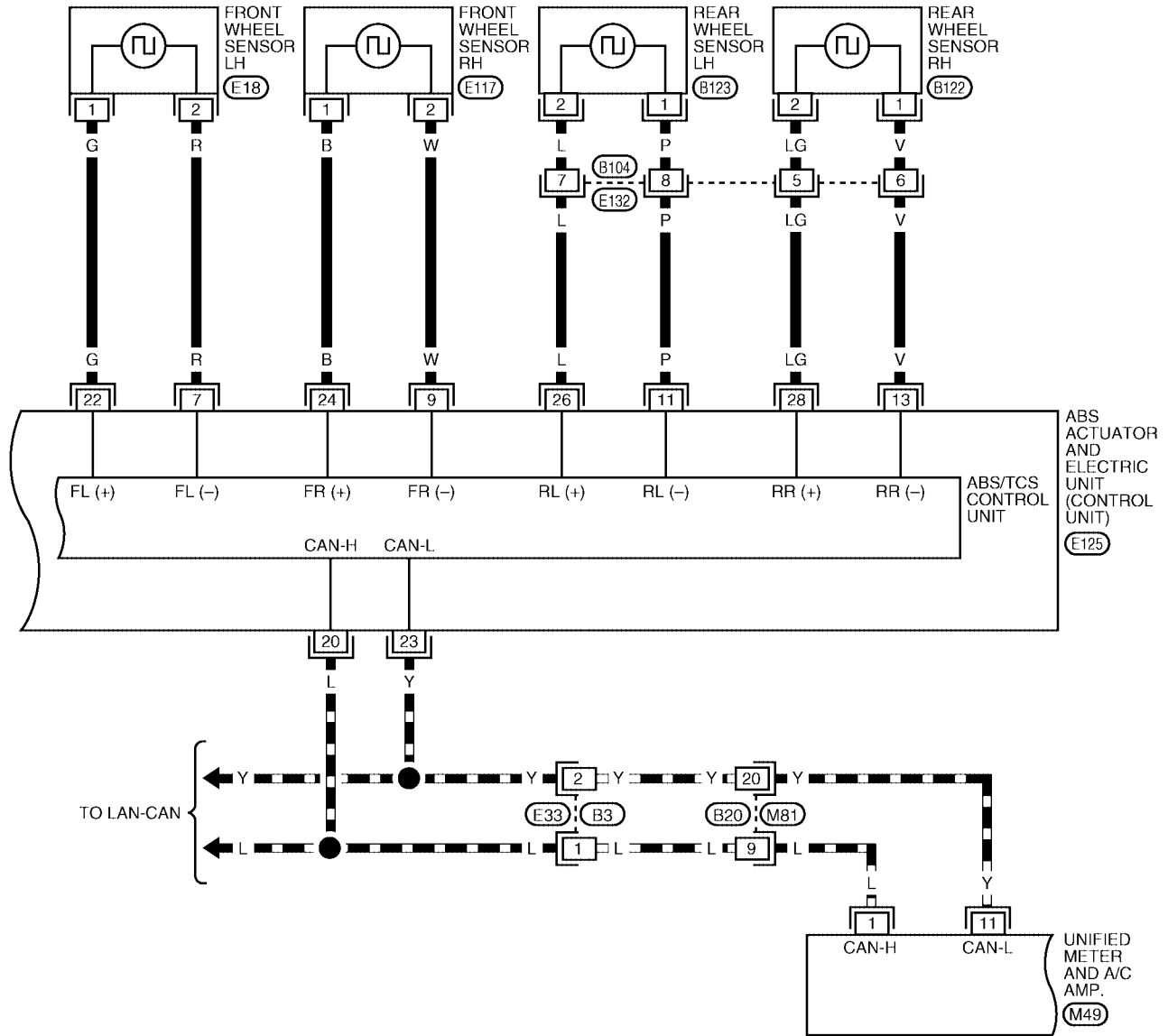

WFWA0025E

# TROUBLE DIAGNOSIS

[TCS/ABS]

BRC-TCS-04

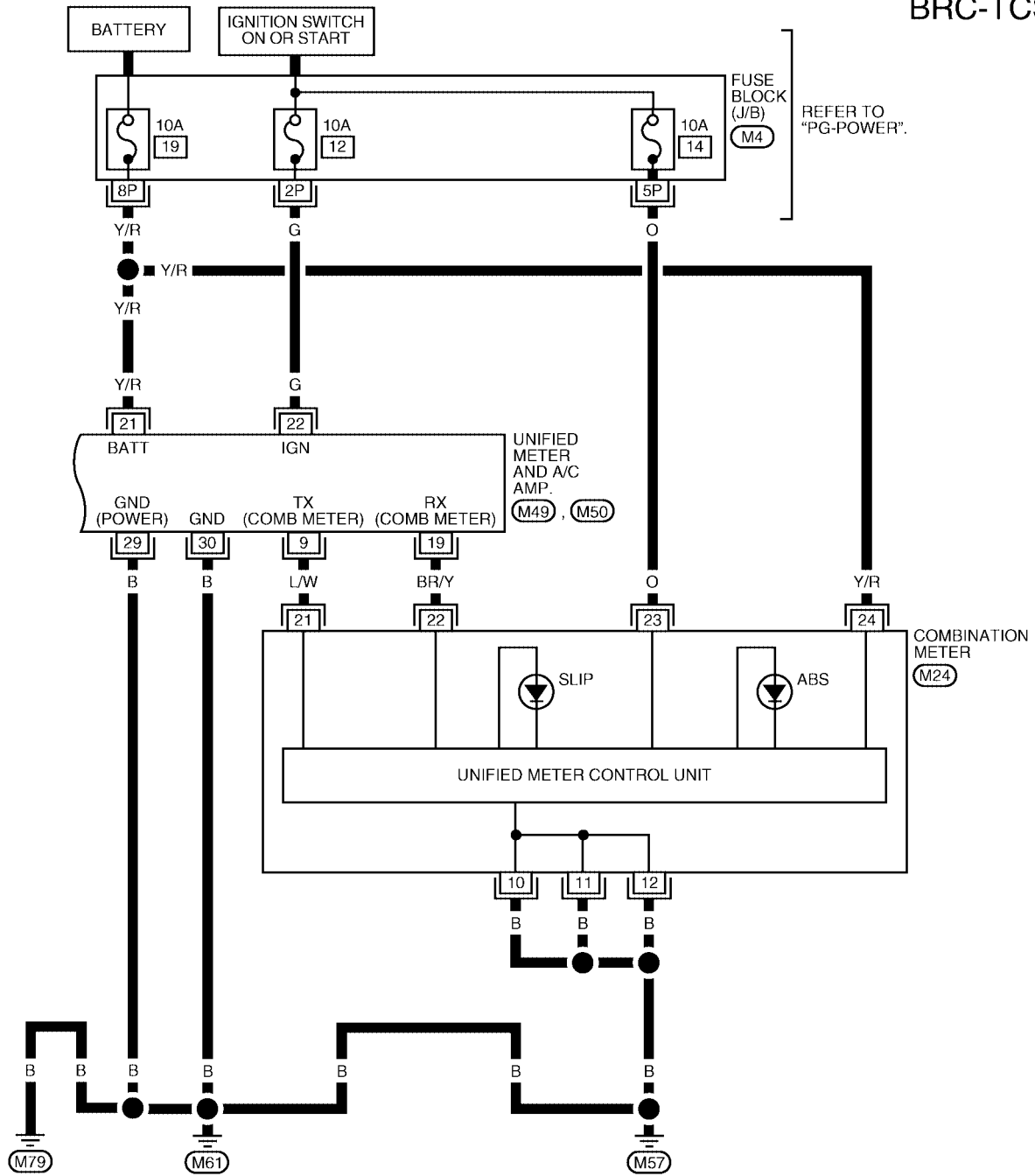

A  
B  
C  
D  
E  
BRC  
G  
H  
I  
J  
K  
L  
M

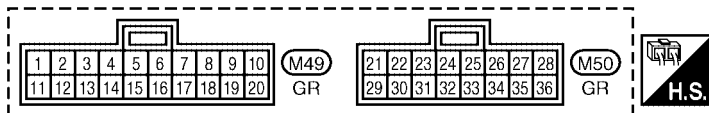
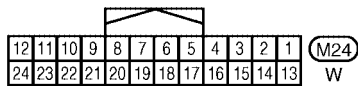

Refer to the following.  
 (M4) - FUSE BLOCK - JUNCTION BOX (J/B)

WFWA0026E

## Basic Inspection

### BRAKE FLUID LEVEL, FLUID LEAK, AND BRAKE PAD INSPECTION

1. Check fluid level in the brake fluid reservoir. If fluid level is low, add fluid.
2. Check the brake piping and around the ABS actuator and electric unit (control unit) for leaks. If there is leaking or seeping fluid, check the following items.
  - If ABS actuator and electric unit (control unit) connection is loose, tighten the piping to the specified torque and recheck for leaks.
  - If there is damage to the connection flare nut or ABS actuator and electric unit (control unit) screw, replace the damaged part and recheck for leaks.
  - When there is fluid leaking or seeping from a fluid connection, use a clean cloth to wipe off the fluid and recheck for leaks. If fluid is still seeping out, replace the damaged part. If the fluid is leaking at the ABS actuator and electric unit (control unit), replace the ABS actuator and electric unit (control unit) assembly.

**CAUTION:**

**The ABS actuator and electric unit (control unit) cannot be disassembled and must be replaced as an assembly.**

3. Check the brake pads for excessive wear.

### POWER SYSTEM TERMINAL LOOSENESS AND BATTERY INSPECTION

Make sure the battery positive cable, negative cable and ground connection are not loose. In addition, make sure the battery is sufficiently charged.

### ABS WARNING LAMP AND SLIP INDICATOR LAMP INSPECTION

1. Make sure ABS warning lamp and SLIP indicator lamp turn on for approximately 1 second when the ignition switch is turned ON. Check CAN communications. If there are no errors with the CAN communication system, check combination meter. Refer to [DI-5, "COMBINATION METERS"](#).
2. Make sure the lamps turn off approximately 1 second after the ignition switch is turned ON. If the lamp does not turn off, conduct self-diagnosis.
3. Make sure ABS warning lamp and SLIP indicator lamp turn off approximately 2 seconds after the engine is started. If ABS warning lamp and SLIP indicator lamp have not turned off 10 seconds after the engine has been started, conduct self-diagnosis of the ABS actuator and electric unit (control unit).
4. After conducting the self-diagnosis, be sure to erase the error memory. Refer to [BRC-65, "CONSULT-II Function \(ABS\)"](#).

### Warning Lamp and Indicator Timing

x: ON    -: Lamp OFF

Condition	ABS warning lamp	TCS OFF indicator lamp	SLIP indicator lamp	Remarks
When the ignition switch is OFF	-	-	-	-
After the ignition switch is turned ON For approx. 0.5 seconds	x	x	x	-
Ignition switch ON Approx. 0.5 seconds later	-	-	-	Lamp goes off approx. 2 seconds after the engine start.
When the TCS OFF switch turns ON (TCS function OFF).	-	x	-	-
TCS/ABS malfunction	x	x	x	-
	x	x	-	When the TCS/ABS control unit is malfunctioning (power supply or ground malfunction).
When the TCS is malfunctioning.	-	x	x	-

# TROUBLE DIAGNOSIS

[TCS/ABS]

EFS002YG

## Control Unit Input/Output Signal Standard

### REFERENCE VALUE FROM CONSULT-II

**CAUTION:**

The display shows the control unit calculation data, so a normal value might be displayed even in the event the output circuit (harness) is open or short circuited.

Monitor item	Display content	Data monitor		Note: Error inspection checklist
		Condition	Reference value in normal operation	
SLCT LVR POSI	PNP switch signal ON/OFF condition	A/T shift position = N or P position	ON	<a href="#">BRC-77, "CAN Communication System Inspection"</a>
		A/T shift position = other than N and P positions	OFF	
GEAR	A/T gear position	1:1st gear 2:2nd gear 3:3rd gear 4:4th gear		<a href="#">BRC-77, "CAN Communication System Inspection"</a>
FR RH SENSOR FR LH SENSOR RR RH SENSOR RR LH SENSOR	Wheel speed	Vehicle stopped	0 [km/h (MPH)]	<a href="#">BRC-72, "Wheel Sensor System Inspection"</a>
		Vehicle running (Note 1)	Almost in accordance with speedometer display (within ±10%)	
ACCEL POS SIG	Open/close condition of throttle valve (linked with accelerator pedal).	Accelerator pedal not depressed (ignition switch is ON)	0%	<a href="#">BRC-77, "CAN Communication System Inspection"</a>
		Depress accelerator pedal (ignition switch is ON)	0 to 100%	
ENGINE SPEED	With engine running	With engine stopped	0 rpm	<a href="#">BRC-73, "Engine System Inspection"</a>
		Engine running	Almost in accordance with tachometer display	
BATTERY VOLT	Battery voltage supplied to ABS actuator and electric unit (control unit)	Ignition switch ON	10 to 16V	<a href="#">BRC-76, "ABS/TCS Control Unit Power and Ground Systems Inspection"</a>
STOP LAMP SW	Brake pedal operation	Brake pedal depressed	ON	<a href="#">BRC-75, "Stop Lamp Switch System Inspection"</a>
		Brake pedal not depressed	OFF	
ABS WARN LAMP	ABS warning lamp ON condition (Note 2)	ABS warning lamp ON	ON	<a href="#">BRC-81, "ABS Warning Lamp Does Not Come On When Ignition Switch Is Turned On"</a>
		ABS warning lamp OFF	OFF	
MOTOR RELAY	Operation status of motor and motor relay	Ignition switch ON or engine running (ABS not operated)	OFF	<a href="#">BRC-74, "Actuator Motor, Motor Relay, and Circuit Inspection"</a>
		Ignition switch ON or engine running (ABS operated)	ON	
ACTUATOR RLY	Actuator relay operation status	Vehicle stopped (Ignition switch ON)	OFF	<a href="#">BRC-74, "Actuator Motor, Motor Relay, and Circuit Inspection"</a>
		Vehicle stopped (Engine running)	ON	
SLIP LAMP	SLIP indicator lamp status (Note 4)	When SLIP indicator lamp is ON	ON	<a href="#">DI-9, "Combination Meter"</a>
		When SLIP indicator lamp is OFF	OFF	

# TROUBLE DIAGNOSIS

**[TCS/ABS]**

Monitor item	Display content	Data monitor		Note: Error inspection checklist
		Condition	Reference value in normal operation	
FR LH IN SOL FR LH OUT SOL FR RH IN SOL FR RH OUT SOL RR RH IN SOL RR RH OUT SOL RR LH IN SOL RR LH OUT SOL	Solenoid valve operation	Actuator (solenoid) is active ("ACTIVE TEST" with CONSULT-II) or actuator relay is inactive (in fail-safe mode).	ON	—
		When actuator (solenoid) is not active and actuator relay is active (ignition switch ON).	OFF	
FLUID LEV SW	ON/OFF status of brake fluid level switch	When brake fluid level switch ON	ON	DI-41. "WARNING LAMPS"
		When brake fluid level switch OFF	OFF	
TCS FAIL SIG ABS FAIL SIG EBD FAIL SIG	Fail signal status	TCS fail ABS fail EBD fail	OFF	TCS system ABS system EBD system

Note 1: Confirm tire pressure is normal.

Note 2: ON/OFF timing of ABS warning lamp

ON: For approximately 1.8 seconds after ignition switch is turned ON, or when a malfunction is detected.

OFF: Approximately 1.8 seconds after ignition switch is turned ON (when system is in normal operation) and TCS function is not activated.

Note 4: SLIP indicator lamp ON/OFF timing

ON: For approximately 1.8 seconds after ignition switch is turned ON, or when a malfunction is detected and TCS function is activated while driving.

OFF: Approximately 1.8 seconds after ignition switch is turned ON (when system is in normal operation) and TCS function is not activated.

Flashing: TCS function is active during driving



## CONSULT-II Function (ABS)

CONSULT-II can display each diagnostic item using the diagnostic test modes shown following.

ABS diagnostic mode	Description
WORK SUPPORT	Supports inspection and adjustments. Commands are transmitted to the ABS actuator and electric unit (control unit) for setting the status suitable for required operation, input/output signals are received from the ABS actuator and electric unit (control unit) and received data is displayed.
SELF-DIAG RESULTS	Displays ABS actuator and electric unit (control unit) self-diagnosis results.
DATA MONITOR	Displays ABS actuator and electric unit (control unit) input/output data in real time.
CAN DIAG SUPPORT MNTR	The result of transmit/receive diagnosis of CAN communication can be read.
ACTIVE TEST	Operation of electrical loads can be checked by sending drive signal to them.
FUNCTION TEST	Conducted by CONSULT-II instead of a technician to determine whether each system is "OK" or "NG".
ECU PART NUMBER	ABS actuator and electric unit (control unit) part number can be read.

### CONSULT-II BASIC OPERATION PROCEDURE

1. Turn ignition switch OFF.
2. Connect CONSULT-II and CONSULT-II CONVERTER to the data link connector.

**CAUTION:**

If CONSULT-II is used with no connection of CONSULT-II CONVERTER, malfunctions might be detected in self-diagnosis depending on control unit which carry out CAN communication.

3. Turn ignition switch ON.

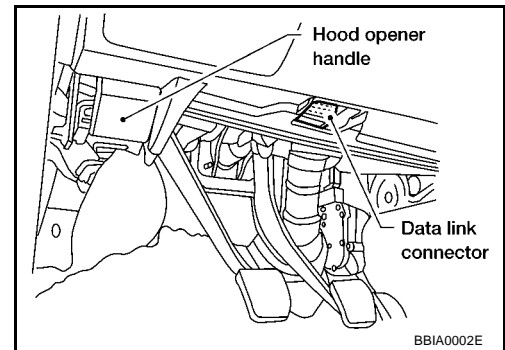

4. Touch "START (NISSAN BASED VHCL)".

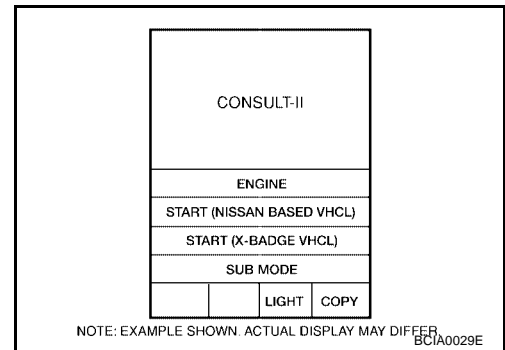

5. Touch "ABS" in the "Select System" screen. If "ABS" is not indicated, go to [GI-36, "CONSULT-II Data Link Connector \(DLC\) Circuit"](#).

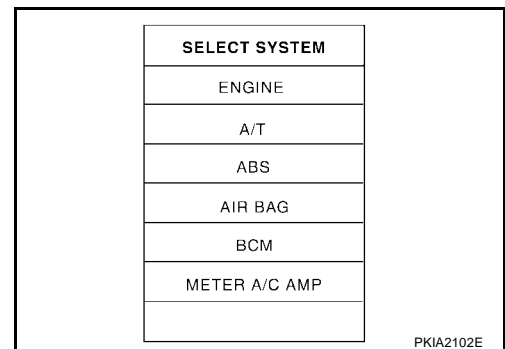

6. Select the required diagnostic location from the "Diagnosis Mode Selection" screen. For further information, see the CONSULT-II Operation Manual.

**SELF-DIAGNOSIS****Description**

If an error is detected in the system, the ABS warning lamp will turn on. In this case, perform self-diagnosis as follows:

**Operation Procedure**

1. Turn ignition switch OFF.
2. Connect CONSULT-II and CONSULT-II CONVERTER to the data link connector.

**CAUTION:**

**If CONSULT-II is used with no connection of CONSULT-II CONVERTER, malfunctions might be detected in self-diagnosis depending on control unit which carry out CAN communication.**

3. Turn ignition switch ON.
4. Start engine and drive at approximately 30 km/h (19 MPH) for approximately 1 minute.
5. After stopping the vehicle, with the engine running, touch "START (NISSAN BASED VHCL)", "ABS", "SELF-DIAG RESULTS" in order on the CONSULT-II screen.

**CAUTION:**

**If "START (NISSAN BASED VHCL)" is touched immediately after starting the engine or turning on the ignition switch, "ABS" might not be displayed in the Select System screen. In this case, repeat the operation from step 1.**

6. The self-diagnostic results are displayed. (If necessary, the self-diagnostic results can be printed out by touching "COPY".)
  - When "NO FAILURE" is displayed, check the ABS warning lamp and SLIP indicator lamp.
7. Conduct the appropriate inspection from the display item list, and repair or replace the malfunctioning component.
8. Start engine and drive at approximately 30 km/h (19 MPH) for approximately 1 minute.

**CAUTION:**

**● When a wheel sensor "short-circuit" is detected, if the vehicle is not driven at 30 km/h (19 MPH) for at least 1 minute, the ABS warning lamp will not turn off even if the malfunction is repaired.**

9. Turn ignition switch OFF to prepare for erasing the memory.
10. Start the engine and touch "START (NISSAN BASED VHCL)", "ABS", "SELF-DIAG RESULTS", "ERASE MEMORY" in order on the CONSULT-II screen to erase the error memory.  
If "ABS" is not indicated, go to [GI-36. "CONSULT-II Data Link Connector \(DLC\) Circuit"](#).

**CAUTION:**

**If the error memory is not erased, re-conduct the operation from step 5.**

11. For the final inspection, drive at approximately 30 km/h (19 MPH) for approximately 1 minute and confirm that the ABS warning lamp and SLIP indicator lamp are off.

# TROUBLE DIAGNOSIS

[TCS/ABS]

## Display Item List

Self-diagnostic item	Malfunction detecting condition	Check system	
FR LH SENSOR 1 [C1104]	Circuit of front LH wheel sensor is open	BRC-72. "Wheel Sensor System Inspection" (Note 1)	
RR RH SENSOR 1 [C1101]	Circuit of rear RH wheel sensor is open		
FR RH SENSOR 1 [C1103]	Circuit of front RH wheel sensor is open		
RR LH SENSOR 1 [C1102]	Circuit of rear LH wheel sensor is open		
FR LH SENSOR 2 [C1108]	Circuit of front LH wheel sensor is shorted, or sensor power voltage is unusual. ABS actuator and electric unit (control unit) cannot identify sensor pulses, because of large gap between wheel sensor and sensor rotor.		
RR RH SENSOR 2 [C1105]	Circuit of rear RH wheel sensor is shorted, or sensor power voltage is unusual. ABS actuator and electric unit (control unit) cannot identify sensor pulses, because of large gap between wheel sensor and sensor rotor.		
FR RH SENSOR 2 [C1107]	Circuit of front RH wheel sensor is shorted, or sensor power voltage is unusual. ABS actuator and electric unit (control unit) cannot identify sensor pulses, because of large gap between wheel sensor and sensor rotor.		
RR LH SENSOR 2 [C1106]	Circuit of rear LH wheel sensor is shorted, or sensor power voltage is unusual. ABS actuator and electric unit (control unit) cannot identify sensor pulses, because of large gap between wheel sensor and sensor rotor.		
STOP LAMP SW 1 [C1116]	Stop lamp switch or circuit malfunction.		BRC-75. "Stop Lamp Switch System Inspection"
FR LH IN ABS SOL [C1120]	Circuit of front LH IN ABS solenoid is open or shorted, or control line is open or shorted to power supply or ground.		
FR LH OUT ABS SOL [C1121]	Circuit of front LH OUT ABS solenoid is open or shorted, or control line is open or shorted to power supply or ground.		
RR RH IN ABS SOL [C1126]	Circuit of rear RH IN ABS solenoid is open or shorted, or control line is open or shorted to power supply or ground.		
RR RH OUT ABS SOL [C1127]	Circuit of rear RH OUT ABS solenoid is open or shorted, or control line is open or shorted to power supply or ground.		
FR RH IN ABS SOL [C1122]	Circuit of front RH IN ABS solenoid is open or shorted, or control line is open or shorted to power supply or ground.		
FR RH OUT ABS SOL [C1123]	Circuit of front RH OUT ABS solenoid is open or shorted, or control line is open or shorted to power supply or ground.		
RR LH IN ABS SOL [C1124]	Circuit of rear LH IN ABS solenoid is open or shorted, or control line is open or shorted to power supply or ground.		
RR LH OUT ABS SOL [C1125]	Circuit of rear LH OUT ABS solenoid is open or shorted, or control line is open or shorted to power supply or ground.		
PUMP MOTOR (Note 3) [C1111]	During actuator motor operation with ON, when actuator motor turns OFF or when control line for actuator motor relay is open.	BRC-74. "Actuator Motor, Motor Relay, and Circuit Inspection"	
	During actuator motor operation with OFF, when actuator motor turns ON or when control line for relay is shorted to ground.		
BATTERY VOLTAGE [ABNORMAL] [C1109]	ABS actuator and electric unit (control unit) power voltage is too low.	BRC-76. "ABS/TCS Control Unit Power and Ground Systems Inspection"	
CONTROLLER FAILURE [C1110]	Internal malfunction of ABS actuator and electric unit (control unit)	BRC-74. "ABS/TCS Control Unit Inspection"	

A  
B  
C  
D  
E  
G  
H  
I  
J  
K  
L  
M

BRC

# TROUBLE DIAGNOSIS

[TCS/ABS]

Self-diagnostic item	Malfunction detecting condition	Check system
CAN COMM CIRCUIT [U1000]	<ul style="list-style-type: none"> <li>● CAN communication line is open or shorted.</li> <li>● ABS actuator and electric unit (control unit) internal malfunction</li> <li>● Battery voltage for ECM is suddenly interrupted for approximately 0.5 seconds or more.</li> </ul>	<a href="#">BRC-77. "CAN Communication System Inspection" (Note 2)</a>
BR FLUID LEVEL LOW [C1155]	Brake fluid level drops or circuit between ABS actuator and electric unit (control unit) and brake fluid level switch is open or shorted.	<a href="#">DI-41. "WARNING LAMPS"</a>
ENGINE SPEED SIG	Engine speed signal from ECM is abnormal.	<a href="#">BRC-73. "Engine System Inspection"</a>
ENGINE SIGNAL 1 [C1130]	ECM judges the communication between ABS/TCS control unit and ECM is abnormal.	<a href="#">BRC-77. "CAN Communication System Inspection"</a>
STOP LAMP SW 2 [C1176]	ASCD brake switch or circuit malfunction.	<a href="#">EC-574. "DTC P1572 ASCD BRAKE SWITCH"</a>

Note 1. If wheel sensor 2 for each wheel is indicated, check ABS actuator and electric unit (control unit) power supply voltage in addition to wheel sensor circuit check.

Note 2. If multiple malfunctions are detected including CAN communication line [U1000], perform diagnosis for CAN communication line first.

Note 3: "ACTUATOR RLY" on the CONSULT-II self-diagnosis results indicates the malfunction of the actuator motor relay or circuit.

## DATA MONITOR

### Operation Procedure

1. After turning OFF the ignition switch, connect CONSULT-II and the CONVERTER to the data link connector.

**CAUTION:**

If CONSULT-II is used with no connection of CONSULT-II CONVERTER, malfunctions might be detected in self-diagnosis depending on control unit which carry out CAN communication.

2. Touch "START (NISSAN BASED VHCL)", "ABS", "DATA MONITOR" in order on the CONSULT-II screen. If "ABS" is not indicated, go to [GI-36. "CONSULT-II Data Link Connector \(DLC\) Circuit"](#).

**CAUTION:**

When "START (NISSAN BASED VHCL)" is touched immediately after starting the engine or turning on the ignition switch, "ABS" might not be displayed in the system selection screen. In this case, repeat the operation from step 2.

3. Return to the Monitor Item Selection screen, and touch "C/U INPUT ITEM", "MAIN ITEM" or "ITEM MENU SELECTION". Refer to the following information.
4. When "START" is touched, the data monitor screen is displayed.

### Display Item List

Item (Unit)	Data monitor item selection			Remarks
	ECU INPUT SIGNALS	MAIN SIGNALS	SELECTION FROM MENU	
GEAR	×	×	×	Gear position judged by PNP switch signal is displayed.
FR RH SENSOR (km/h, MPH)	×	×	×	Wheel speed calculated by front RH wheel sensor signal is displayed.
FR LH SENSOR (km/h, MPH)	×	×	×	Wheel speed calculated by front LH wheel sensor signal is displayed.
RR RH SENSOR (km/h, MPH)	×	×	×	Wheel speed calculated by rear RH wheel sensor signal is displayed.
RR LH SENSOR (km/h, MPH)	×	×	×	Wheel speed calculated by rear LH wheel sensor signal is displayed.

# TROUBLE DIAGNOSIS

[TCS/ABS]

Item (Unit)	Data monitor item selection			Remarks
	ECU INPUT SIGNALS	MAIN SIGNALS	SELECTION FROM MENU	
BATTERY VOLT (V)	×	×	×	Voltage supplied to ABS actuator and electric unit (control unit) is displayed.
SLCT LVR POSI	×	×	×	Shift position judged by PNP switch signal.
ACCEL POS SIG (%)	×	—	×	Throttle valve open/close status judged by LAN communication signal is displayed.
ENGINE SPEED (rpm)	×	×	×	Engine speed judged by LAN communication signal is displayed.
STOP LAMP SW (ON/OFF)	×	×	×	Stop lamp switch (ON/OFF) status is displayed.
ABS WARN LAMP (ON/OFF)	—	×	×	ABS warning lamp (ON/OFF) status is displayed.
SLIP LAMP (ON/OFF)	—	×	×	SLIP indicator lamp (ON/OFF) status is displayed.
FR LH IN SOL (ON/OFF)	—	×	×	Front LH IN ABS solenoid (ON/OFF) status is displayed.
FR LH OUT SOL (ON/OFF)	—	×	×	Front LH OUT ABS solenoid (ON/OFF) status is displayed.
RR RH IN SOL (ON/OFF)	—	×	×	Rear RH IN ABS solenoid (ON/OFF) status is displayed.
RR RH OUT SOL (ON/OFF)	—	×	×	Rear RH OUT ABS solenoid (ON/OFF) status is displayed.
FR RH IN SOL (ON/OFF)	—	×	×	Front RH IN ABS solenoid (ON/OFF) status is displayed.
FR RH OUT SOL (ON/OFF)	—	×	×	Front RH OUT ABS solenoid (ON/OFF) status is displayed.
RR LH IN SOL (ON/OFF)	—	×	×	Rear LH IN ABS solenoid (ON/OFF) status is displayed.
RR LH OUT SOL (ON/OFF)	—	×	×	Rear LH OUT ABS solenoid (ON/OFF) status is displayed.
OFF LAMP (ON/OFF)	—	×	×	OFF Lamp (ON/OFF) status is displayed.
MOTOR RELAY (ON/OFF)	—	×	×	ABS motor relay signal (ON/OFF) status is displayed.
ACTUATOR RLY (ON/OFF)	—	×	×	ABS actuator relay signal (ON/OFF) status is displayed.
TCS FAIL SIG (ON/OFF)	—	—	×	TCS fail signal (ON/OFF) status is displayed.
ABS FAIL SIG (ON/OFF)	—	—	×	ABS fail signal (ON/OFF) status is displayed.
EBD FAIL SIG (ON/OFF)	—	—	×	EBD fail signal (ON/OFF) status is displayed.
FLUID LEV SW (ON/OFF)	×	—	×	Brake fluid level switch (ON/OFF) status is displayed.
EBD SIGNAL (ON/OFF)	—	—	×	EBD operation (ON/OFF) status is displayed.
ABS SIGNAL (ON/OFF)	—	—	×	ABS operation (ON/OFF) status is displayed.

A

B

C

D

E

BRC

G

H

I

J

K

L

M

# TROUBLE DIAGNOSIS

[TCS/ABS]

Item (Unit)	Data monitor item selection			Remarks
	ECU INPUT SIGNALS	MAIN SIGNALS	SELECTION FROM MENU	
TCS SIGNAL (ON/OFF)	–	–	×	TCS operation (ON/OFF) status is displayed.
TRQ MAP S/C	–	–	×	S/C is selected for engine torque map
TRQ MAP N/A	–	–	×	N/A is selected for engine

×: Applicable

–: Not applicable

## ACTIVE TEST

### CAUTION:

- Do not perform active test while driving.
- Make sure to completely bleed air from the brake system.
- The ABS and brake (EBD) warning lamps turn on during the active test.

### Operation Procedure

1. Connect the CONSULT-II and CONVERTER to the data link connector and start the engine.

### CAUTION:

If CONSULT-II is used with no connection of CONSULT-II CONVERTER, malfunctions might be detected in self-diagnosis depending on control unit which carry out CAN communication.

2. Touch "START (NISSAN BASED VHCL)" on the display screen.
3. Touch "ABS".  
If "ABS" is not indicated, go to [GI-36. "CONSULT-II Data Link Connector \(DLC\) Circuit"](#).
4. Touch "ACTIVE TEST".
5. The test item selection screen is displayed.
6. Touch necessary test item.

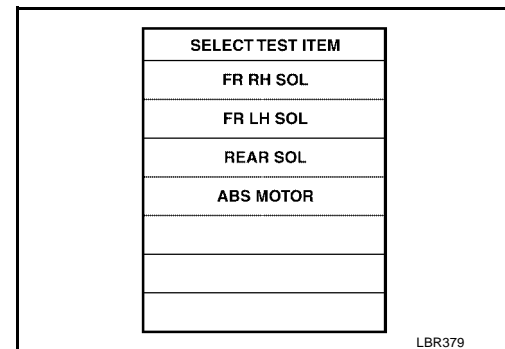

7. With the "MAIN ITEM" display shown in reverse, touch "START".
8. The Active Test screen will be displayed, so conduct the following test.

### Solenoid Valve Operation Chart

Operation		ABS solenoid valve			ABS solenoid valve (ACT)		
		UP	KEEP	DOWN	UP	ACTUA-TOR UP	ACTUA-TOR KEEP
FR RH SOL FR RH ABS SOLE- NOID (ACT)	FR RH IN SOL	OFF	ON	ON	OFF	OFF	OFF
	FR RH OUT SOL	OFF	OFF	ON*	OFF	OFF	OFF
FR LH SOL FR LH ABS SOLE- NOID (ACT)	FR LH IN SOL	OFF	ON	ON	OFF	OFF	OFF
	FR LH OUT SOL	OFF	OFF	ON*	OFF	OFF	OFF
RR RH SOL RR RH ABS SOLE- NOID (ACT)	RR RH IN SOL	OFF	ON	ON	OFF	OFF	OFF
	RR RH OUT SOL	OFF	OFF	ON*	OFF	OFF	OFF

# TROUBLE DIAGNOSIS

[TCS/ABS]

Operation		ABS solenoid valve			ABS solenoid valve (ACT)		
		UP	KEEP	DOWN	UP	ACTUA-TOR UP	ACTUA-TOR KEEP
RR LH SOL RR LH ABS SOLE- NOID (ACT)	RR LH IN SOL	OFF	ON	ON	OFF	OFF	OFF
	RR LH OUT SOL	OFF	OFF	ON*	OFF	OFF	OFF
REAR SOL	RR RH IN SOL	OFF	ON	ON	OFF	OFF	OFF
	RR RH OUT SOL	OFF	OFF	ON*	OFF	OFF	OFF
	RR LH IN SOL	OFF	ON	ON	OFF	OFF	OFF
	RR LH OUT SOL	OFF	OFF	ON*	OFF	OFF	OFF

\*: ON for 1 to 2 seconds after the touch, and then OFF

**NOTE:**

- If active test is performed with brake pedal depressed, pedal stroke may change. This is normal.
- "TEST IS STOPPED" is displayed approximately 10 seconds after operation starts.
- After "TEST IS STOPPED" is displayed, to perform test again, repeat Step 6.

**ABS Motor**

Touch "ON" and "OFF" on the screen. Check that ABS motor relay operates as shown in table below.

Operation	ON	OFF
ABS actuator relay	ON	ON
ABS motor relay	ON	OFF

**NOTE:**

- If active test is performed with brake pedal depressed, pedal stroke may change. This is normal.
- "TEST IS STOPPED" is displayed approximately 10 seconds after operation starts.

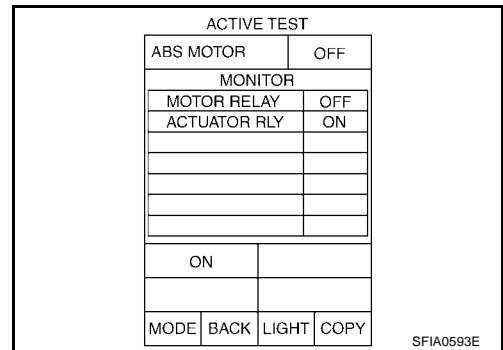

**TROUBLE DIAGNOSIS FOR SELF-DIAGNOSTIC ITEMS**

PFP:00000

EFS002ZW

**Wheel Sensor System Inspection**

## INSPECTION PROCEDURE

**1. CONNECTOR INSPECTION**

Disconnect the ABS actuator and electric unit connector E125 and wheel sensor of malfunctioning code. Check the terminals for deformation, disconnection, looseness or damage.

OK or NG

- OK >> GO TO 2.  
NG >> Repair or replace as necessary.

**2. CHECK WHEEL SENSOR OUTPUT SIGNAL**

1. Disconnect connectors from wheel sensor of malfunction code No.
2. Connect ABS active wheel sensor tester (J-45741) to wheel sensor using appropriate adapter.
3. Turn on the ABS active wheel sensor tester power switch.

**NOTE:**

The green POWER indicator should illuminate. If the POWER indicator does not illuminate, replace the battery in the ABS active wheel sensor tester before proceeding.

4. Spin the wheel of the vehicle by hand and observe the red SENSOR indicator on the ABS active wheel sensor tester. The red SENSOR indicator should flash on and off to indicate an output signal.

**NOTE:**

If the red SENSOR indicator illuminates but does not flash, reverse the polarity of the tester leads and retest.

Does the ABS active wheel sensor tester detect a signal?

- Yes >> GO TO 3.  
No >> GO TO 6.

**3. CHECK TIRES**

Check for inflation pressure, wear and size of each tire.

Are tire pressure and size correct and is tire wear within specifications?

- Yes >> GO TO 4.  
No >> Adjust tire pressure or replace tire(s).

**4. CHECK WHEEL BEARINGS**

Check wheel bearing axial end play. Refer to [FAX-5, "FRONT WHEEL BEARING"](#) or [RAX-5, "REAR WHEEL BEARING"](#).

OK or NG

- OK >> GO TO 5.  
NG >> Repair as necessary. Refer to [FAX-5, "FRONT WHEEL BEARING"](#) or [RAX-5, "REAR WHEEL BEARING"](#).

**5. CHECK SENSOR ROTORS**

Check sensor rotors for teeth damage.

OK or NG

- OK >> GO TO 6.  
NG >> Replace sensor rotor. Refer to [BRC-137, "Removal and Installation"](#).



**6. CHECK WIRING HARNESS FOR SHORT CIRCUIT**

1. Disconnect ABS actuator and electric unit (control unit) connector and wheel sensor connector of malfunction code No.
2. Check resistance between harness connector terminal and ground.

**Continuity should not exist.**

OK or NG

- OK >> GO TO 7.
- NG >> Repair the circuit.

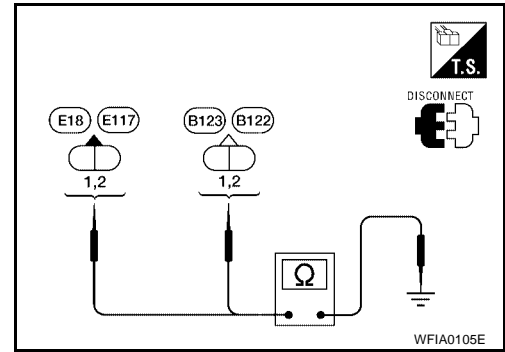

**7. CHECK WIRING HARNESS FOR OPEN CIRCUIT**

1. Disconnect ABS actuator and electric unit (control unit) connector and wheel sensor connector of malfunction code No.
2. Check continuity between both wiring harness ends.

Sensor	ABS actuator and electric unit (control unit)		Wheel sensor		Continuity
	Connector - terminal	Wire color	Connector - terminal	Wire color	
Front LH	E125 - 22	G	E18 - 1	G	Yes
	E125 - 7	R	E18 - 2	R	
Front RH	E125 - 24	B	E117 - 1	B	
	E125 - 9	W	E117 - 2	W	
Rear LH	E125 - 11	P	B123 - 1	P	
	E125 - 26	L	B123 - 2	L	
Rear RH	E125 - 13	V	B122 - 1	V	
	E125 - 28	LG	B122 - 2	LG	

**Continuity should exist.**

OK or NG

- OK >> Replace the ABS actuator and electric unit (control unit). Refer to [BRC-85, "Removal and Installation"](#).
- NG >> Repair the circuit.

**Engine System Inspection**

EFS002ZX

INSPECTION PROCEDURE

**1. SELF-DIAGNOSIS RESULT CHECK**

Check self-diagnosis results.

Self-diagnosis results
ENGINE SIGNAL 1

Is the above displayed in the self-diagnosis display items?

- Yes >> GO TO 2.
- No >> **INSPECTION END.**

## 2. ENGINE SYSTEM INSPECTION

1. Perform ECM self-diagnosis and repair as necessary.
2. Perform ABS actuator and electric unit (control unit) self-diagnosis again.

OK or NG

- OK >> **INSPECTION END.**  
 NG >> Repair as necessary.

### ABS/TCS Control Unit Inspection

EFS002ZY

INSPECTION PROCEDURE

#### 1. SELF-DIAGNOSIS RESULT CHECK

Check self-diagnosis results.

Self-diagnosis results
CONTROLLER FAILURE

Is the above displayed in the self-diagnosis display items?

- Yes >> Replace ABS actuator and electric unit. Refer to [BRC-85, "Removal and Installation"](#) .  
 No >> **INSPECTION END.**

### Actuator Motor, Motor Relay, and Circuit Inspection

EFS00302

INSPECTION PROCEDURE

#### 1. CHECKING SELF-DIAGNOSIS RESULTS

Check self-diagnosis results.

Self-diagnosis results
CONSULT-II display items
PUMP MOTOR

Does "PUMP MOTOR" appear in self-diagnosis results display?

- Yes >> GO TO 2.  
 No >> **INSPECTION END.**

## 2. CONNECTOR INSPECTION

Disconnect the ABS actuator and electric unit connector E125.  
 Check the terminals for deformation, disconnection, looseness or damage.

OK or NG

- OK >> GO TO 3.  
 NG >> Repair or replace as necessary.

## 3. CHECKING ABS MOTOR AND MOTOR RELAY POWER SYSTEM

1. Disconnect ABS actuator and electric unit (control unit) connector.
2. Check voltage between ABS actuator and electric unit (control unit) connector E125 and body ground.

ABS actuator and electric unit (control unit) connector E125	Body ground	Measured value (Approx.)
1 (R/B)	—	12V

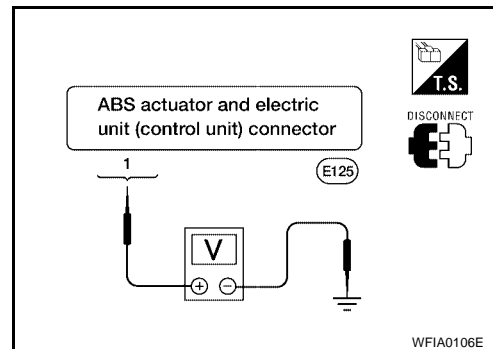

3. Check resistance between ABS actuator and electric unit (control unit) connector E125 and ground.

ABS actuator and electric unit (control unit) connector E125	Body ground	Measured value (Approx.)
30 (B)	—	0Ω

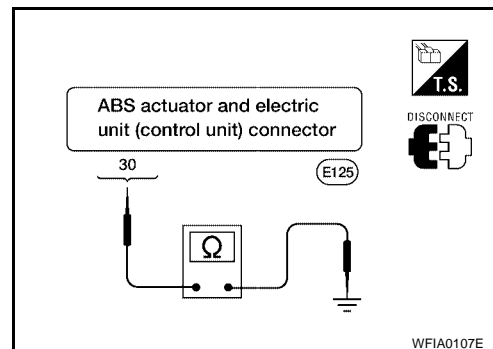

OK or NG

OK >> Perform self-diagnosis again. If the same result appears, replace ABS actuator and electric unit (control unit). Refer to [BRC-85, "Removal and Installation"](#).

NG >> Repair the circuit.

## Stop Lamp Switch System Inspection

EFS00304

### INSPECTION PROCEDURE

#### 1. SELF-DIAGNOSIS RESULT CHECK

Check self-diagnosis results.

Self-diagnosis results
STOP LAMP SW

Is the above displayed in the self-diagnosis display items?

Yes >> GO TO 2.

No >> **INSPECTION END.**

#### 2. CONNECTOR INSPECTION

1. Disconnect the ABS actuator and electric unit connector E125 and stop lamp switch connector E38.
2. Check the terminals for deformation, disconnection, looseness or damage.

OK or NG

OK >> GO TO 3.

NG >> Repair or replace as necessary.

### 3. STOP LAMP SWITCH INSPECTION

Turn the ignition switch on and check the voltage between the ABS actuator and electric unit connector E125 terminal 17 (R/G) and ground.

**17 (R/G) - Ground**

**Brake pedal depressed : Battery voltage (approx. 12V)**

**Brake pedal not depressed : Approx. 0V**

OK or NG

OK >> Connect the connectors and conduct ABS actuator and electric unit self-diagnosis.

NG >> Repair the circuit.

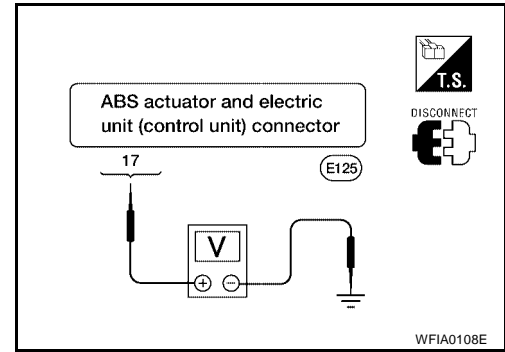

### ABS/TCS Control Unit Power and Ground Systems Inspection

EFS00305

INSPECTION PROCEDURE

#### 1. SELF-DIAGNOSIS RESULT CHECK

Check self-diagnosis results.

Self-diagnosis results
BATTERY VOLTAGE

Is the above displayed in the self-diagnosis item?

Yes >> GO TO 2.

No >> **INSPECTION END.**

#### 2. CONNECTOR INSPECTION

1. Turn the ignition switch off and disconnect the ABS actuator and electric unit connector E125.
2. Check the terminals for deformation, disconnection, looseness or damage.

OK or NG

OK >> GO TO 3.

NG >> Repair or replace as necessary.

#### 3. ABS/TCS CONTROL UNIT POWER AND GROUND CIRCUIT INSPECTION

Measure the voltage and continuity between the ABS actuator and electric unit connector E125 and the ground.

Signal name	ABS actuator and electric unit (control unit) connector E125	Ground	Measured value
Power supply	29 (GR)	—	Battery voltage (Approx. 12V)
Ground	16 (B)		Continuity should exist.
	30 (B)		

OK or NG

OK >> Check the battery for loose terminals, low voltage, etc. Repair as necessary.

NG >> Repair the circuit.

**CAN Communication System Inspection**

## INSPECTION PROCEDURE

**1. CHECK CONNECTOR**

1. Turn ignition switch OFF, disconnect the ABS actuator and electric unit (control unit) connector, and check the terminal for deformation, disconnection, looseness, and so on. If there is a malfunction, repair or replace the terminal.
2. Reconnect connector to perform self-diagnosis.

Is "CAN COMM CIRCUIT" displayed in the self-diagnosis display items?

- Yes >> Print out the self-diagnosis results, and refer to [LAN-8, "CAN COMMUNICATION"](#) .
- No >> Connector terminal connection is loose, damaged, open, or shorted.

A

B

C

D

E

BRC

G

H

I

J

K

L

M

---

**TROUBLE DIAGNOSES FOR SYMPTOMS****ABS Works Frequently**

---

**1. CHECK WARNING LAMP ACTIVATION**

---

Make sure warning lamp remains off while driving.

OK or NG

OK >> GO TO 2.

NG >> Carry out self-diagnosis. Refer to [BRC-66, "SELF-DIAGNOSIS"](#) .

---

**2. CHECK WHEEL SENSORS**

---

Check the following.

- Wheel sensor mounting for looseness
- Wheel sensors for physical damage
- Wheel sensor connectors for terminal damage or loose connections

OK or NG

OK >> GO TO 3.

NG >> Repair as necessary.

---

**3. CHECK FRONT AXLE**

---

Check front and rear axles for excessive looseness. Refer to [FAX-5, "FRONT WHEEL BEARING"](#) or [RAX-5, "REAR WHEEL BEARING"](#) .

OK or NG

OK >> GO TO 4.

NG >> Repair as necessary.

---

**4. CHECK BRAKE FLUID PRESSURE**

---

Check brake fluid pressure distribution.

Refer to [BR-36, "Inspection"](#) .

Is brake fluid pressure distribution normal?

Yes >> **INSPECTION END.**

No >> Perform Basic Inspection. Refer to [BRC-62, "Basic Inspection"](#) .

**Unexpected Pedal Action****1. CHECK WARNING LAMP ACTIVATION**

Make sure warning lamp remains off while driving.

OK or NG

OK >> GO TO 2.

NG >> Carry out self-diagnosis. Refer to [BRC-66, "SELF-DIAGNOSIS"](#) .

**2. CHECK BRAKE PEDAL STROKE**

Check brake pedal stroke.

Is pedal stroke excessive?

Yes >> Perform Basic Inspection. Refer to [BRC-62, "Basic Inspection"](#) .

No >> GO TO 3.

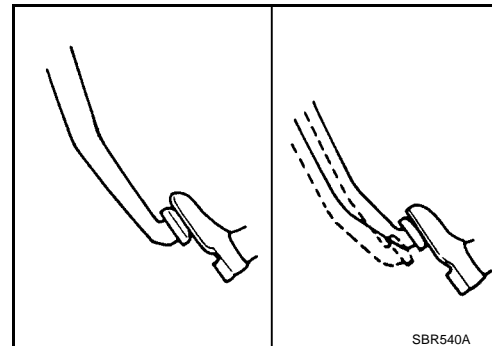
**3. CHECK CONNECTOR AND BRAKING PERFORMANCE**

1. Disconnect ABS actuator and electric unit (control unit) connector.

2. Check brake effectiveness.

OK or NG

OK >> GO TO 4.

NG >> Perform Basic Inspection. Refer to [BRC-62, "Basic Inspection"](#) .

**4. CHECK WHEEL SENSORS**

Check the following.

- Wheel sensor mounting for looseness
- Wheel sensors for physical damage
- Wheel sensor connectors for terminal damage or loose connections

OK or NG

OK >> Check ABS actuator and electric unit (control unit) pin terminals for damage and the connection of harness connector. Reconnect ABS actuator and electric unit (control unit) harness connector. Then retest.

NG >> Repair as necessary.

## Long Stopping Distance

### 1. CHECK BASE BRAKING SYSTEM PERFORMANCE

---

1. Disable ABS by disconnecting ABS actuator and electric unit (control unit) connector.
2. Drive vehicle and check to see if stopping distance is still long.

#### OK or NG

- OK >> Go to [BRC-78, "ABS Works Frequently"](#) .  
 NG >> Perform Basic Inspection. Refer to [BRC-62, "Basic Inspection"](#) .

#### NOTE:

Stopping distance may be longer than vehicles without ABS when road condition is slippery.

## ABS Does Not Work

#### CAUTION:

The ABS does not operate when the vehicle speed is 10 km/h (6 MPH) or less.

### 1. CHECK WARNING LAMP ACTIVATION

---

Turn ignition switch ON and check for warning lamp activation.

- Warning lamp should activate for approximately 1 second after turning the ignition switch ON.

#### OK or NG

- OK >> Carry out self-diagnosis. Refer to [BRC-66, "SELF-DIAGNOSIS"](#) .  
 NG >> Go to [BRC-81, "ABS Warning Lamp Does Not Come On When Ignition Switch Is Turned On"](#) .

## Pedal Vibration or ABS Operation Noise

#### NOTE:

During ABS activation, pedal vibration may be felt and a noise may be heard. This is normal and does not indicate a malfunction.

### 1. CHECK SYMPTOM

---

1. Apply brake.
2. Start engine.

Does the symptom occur only when engine is started?

- Yes >> Carry out self-diagnosis. Refer to [BRC-66, "SELF-DIAGNOSIS"](#) .  
 No >> GO TO 2.

### 2. RECHECK SYMPTOM

---

Does the symptom occur only when electrical equipment switches (such as headlamp) are turned on?

- Yes >> Check for radio, antenna or related wiring that is routed too close to the ABS actuator and electric unit (control unit) and reroute as necessary.  
 No >> Go to [BRC-78, "ABS Works Frequently"](#) .



**ABS Warning Lamp Does Not Come On When Ignition Switch Is Turned On** EFS002Z0

**1. CHECK ABS ACTUATOR AND ELECTRIC UNIT (CONTROL UNIT) FUSES**

Check 30A fusible link **g** and 30A fusible link **h** for ABS actuator and electric unit (control unit). For fusible link layout, refer to [PG-3, "POWER SUPPLY ROUTING CIRCUIT"](#).

OK or NG

- OK >> GO TO 2.
- NG >> If fusible link is blown, be sure to eliminate cause of problem before replacing.

**2. CHECK ABS ACTUATOR AND ELECTRIC UNIT (CONTROL UNIT) POWER SUPPLY CIRCUITS**

1. Disconnect ABS actuator and electric unit (control unit) connector.
2. Check voltage between ABS actuator connector terminal 1 and ground and terminal 15 and ground.

Does battery voltage exist?

- Yes >> GO TO 3.
- No >> Repair harness or connectors between fusible link and ABS actuator and electric unit (control unit).

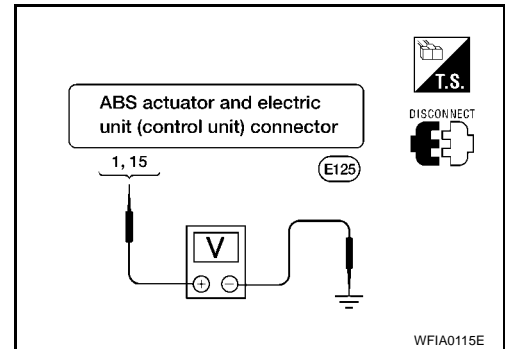

**3. CHECK ABS ACTUATOR AND ELECTRIC UNIT (CONTROL UNIT) GROUND CIRCUIT**

Check continuity between ABS actuator connector terminal 16 and ground and terminal 30 and ground.

Does continuity exist?

- Yes >> Replace ABS actuator and electric unit (control unit).
- No >> Repair harness or connectors between ABS actuator and electric unit (control unit) and ground.

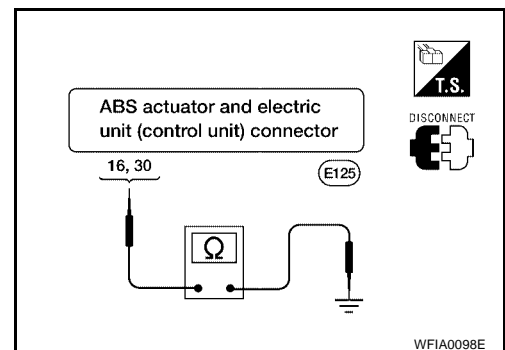

**ABS Warning Lamp Stays On When Ignition Switch Is Turned On** EFS002Z1

**1. CARRY OUT SELF-DIAGNOSIS**

Carry out self-diagnosis. Refer to [BRC-66, "SELF-DIAGNOSIS"](#).

Are malfunctions detected in self-diagnosis?

- Yes >> Refer to [BRC-68, "Display Item List"](#).
- No >> Refer to [DI-41, "WARNING LAMPS"](#).

---

## Vehicle Jerks During TCS Activation

### 1. ABS ACTUATOR AND ELECTRIC UNIT (CONTROL UNIT) SELF-DIAGNOSIS

---

Perform ABS actuator and electric unit (control unit) self-diagnosis.

Are self-diagnosis result items displayed?

- Yes >> After checking and repairing the applicable item, perform the ABS actuator and electric unit (control unit) self-diagnosis again.
- No >> GO TO 2.

### 2. ENGINE SPEED SIGNAL INSPECTION

---

Perform data monitor with CONSULT-II for the ABS actuator and electric unit (control unit).

Is the engine speed at idle 400 rpm or higher?

- Yes >> With A/T, GO TO 4. With M/T, GO TO 5.
- No >> GO TO 3.

### 3. ECM SELF-DIAGNOSIS

---

Perform ECM self-diagnosis.

Are self-diagnosis result items displayed?

- Yes >> After checking and repairing the applicable item, perform the ECM self-diagnosis again.
- No >> With A/T, GO TO 4. With M/T, GO TO 5.

### 4. TCM SELF-DIAGNOSIS

---

Perform TCM self-diagnosis.

Are self-diagnosis result items displayed?

- Yes >> After checking and repairing the applicable item, perform the ECM self-diagnosis again.
- No >> GO TO 5.

### 5. CONNECTOR INSPECTION

---

Disconnect the ABS actuator and electric unit (control unit) connector and the ECM connectors and check the terminals for deformation, disconnection, looseness or damage.

OK or NG

- OK >> GO TO 6.
- NG >> Repair or replace the connector terminal.

### 6. CAN COMMUNICATION INSPECTION

---

Check the CAN communication system. Refer to [BRC-77, "CAN Communication System Inspection"](#) .

OK or NG

- OK >> **INSPECTION END.**
- NG >> Reconnect the connectors, and perform ABS actuator and electric unit (control unit) self-diagnosis.

WHEEL SENSORS

Removal and Installation

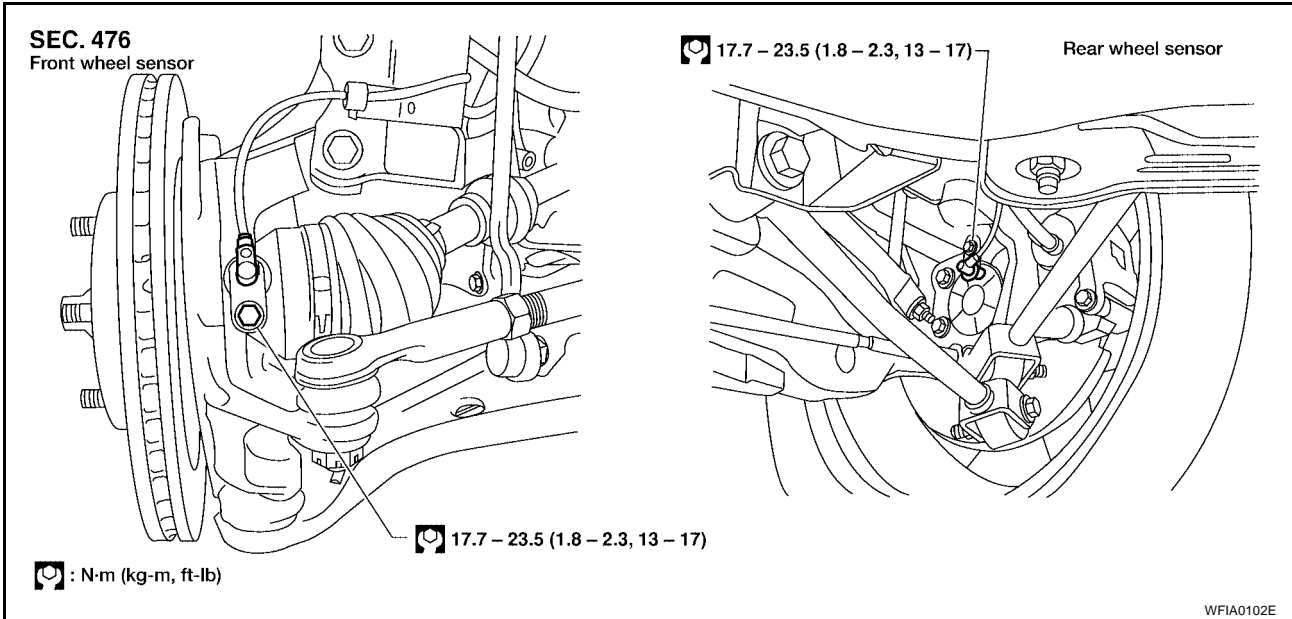

**CAUTION:**

**Be careful not to damage sensor edge and sensor rotor teeth.**

When removing the front or rear wheel hub assembly, first remove the ABS wheel sensor from the assembly. Failure to do so may result in damage to the sensor wires making the sensor inoperative.

**CAUTION:**

**Pull out the sensor being careful to turn it as little as possible. Do not pull on the sensor harness. Installation should be performed while paying attention to the following, and then tighten fasteners to the specified torque.**

- Before installing wheel sensor, make sure no foreign materials (such as iron fragments) are adhered to the pick-up part of the sensor, to the inside of the sensor mounting hole or on the rotor mounting surface.

A  
B  
C  
D  
E  
BRC  
G  
H  
I  
J  
K  
L  
M

## SENSOR ROTOR

PFP:47970

### Removal and Installation

EFS002W4

#### NOTE:

The rear wheel sensor rotor is built into the rear wheel hub. For removal and installation procedure, refer to [RAX-6, "Removal and Installation"](#).

#### REMOVAL

1. Remove the front wheel hub. Refer to [FAX-6, "Removal and Installation"](#).
2. Remove the sensor rotor using suitable puller.

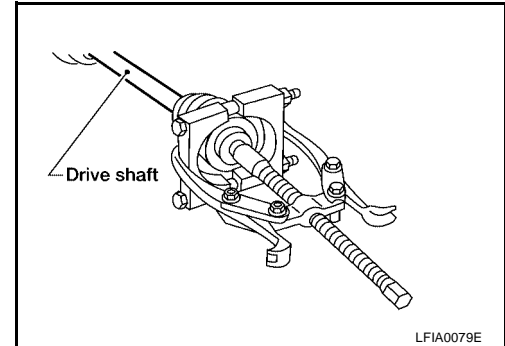

#### INSTALLATION

Install the sensor rotor using a hammer and a wooden block.

- Always replace sensor rotor with new one.

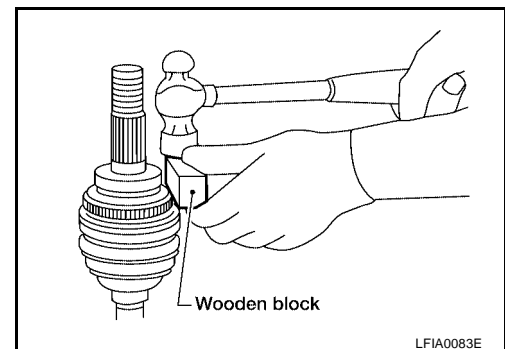

## ACTUATOR AND ELECTRIC UNIT (ASSEMBLY)

PFPA:47660

### Removal and Installation

EFS002W9

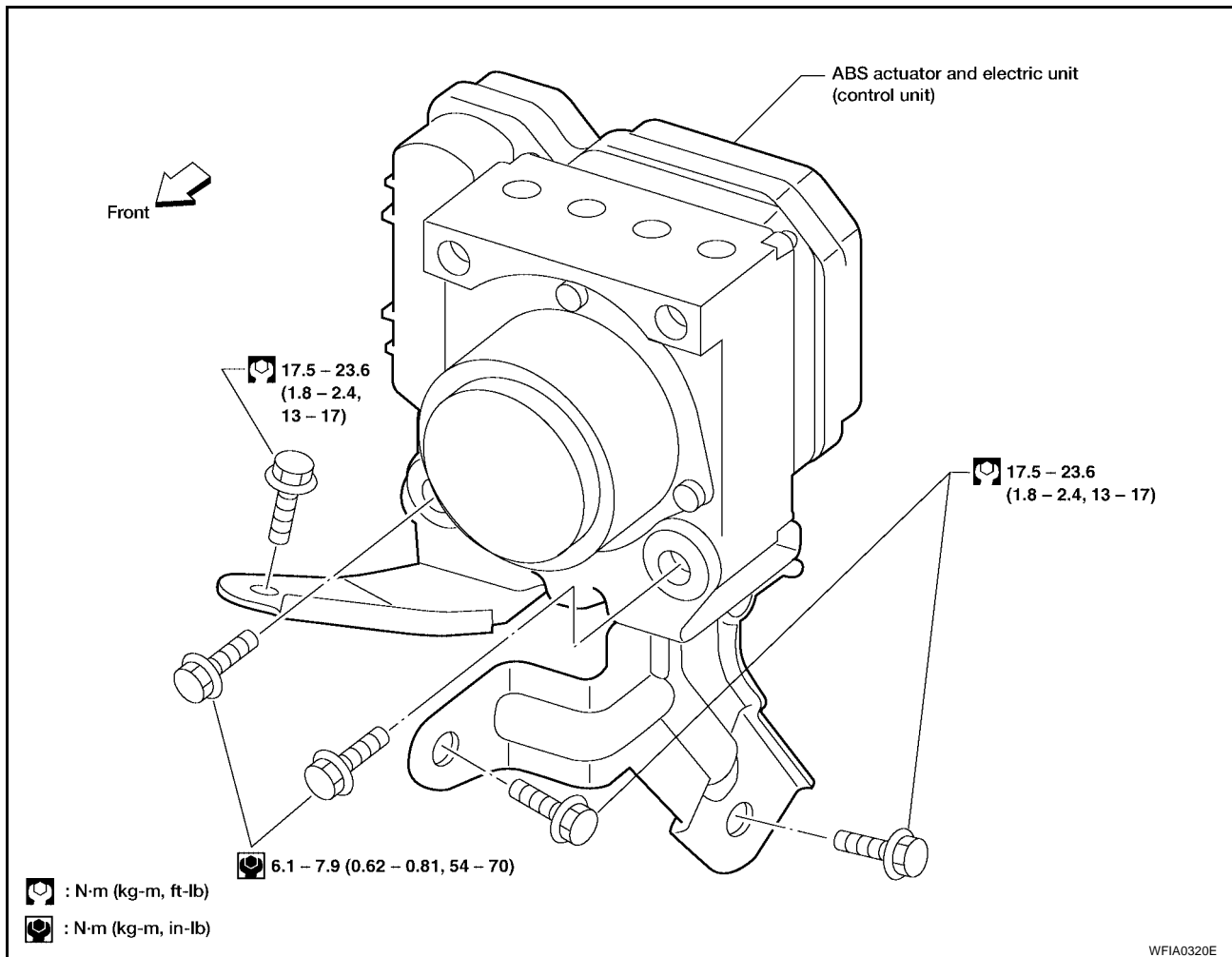

### REMOVAL

1. Disconnect battery cable.
2. Remove windshield wiper and linkage assembly. Refer to [WW-26, "REMOVAL"](#).
3. Drain brake fluid. Refer to [BR-8, "Changing Brake Fluid"](#).
4. Discharge the A/C refrigerant. Refer to [ATC-116, "HFC-134a \(R-134a\) Service Procedure"](#).
5. Disconnect and remove high-pressure and low-pressure A/C pipes to allow access to ABS actuator and electric unit (control unit). Refer to [ATC-118, "Components"](#).
6. Disconnect harness connectors from ABS actuator and electric unit (control unit).
7. Disconnect brake pipes.
8. Remove fasteners for ABS actuator and electric unit (control unit) and remove from vehicle.

### INSTALLATION

#### CAUTION:

After installation of ABS actuator and electric unit (control unit), refill brake fluid. Then bleed air from system. Refer to [BR-8, "Bleeding Brake System"](#).

1. Position ABS actuator and electric unit (control unit) in vehicle.
2. Connect brake pipes and fasteners temporarily.
3. Tighten fasteners and brake pipes.
4. Connect ABS actuator and electric unit (control unit) harness connectors.
5. Install and connect high-pressure and low-pressure A/C pipes. Refer to [ATC-118, "Components"](#).
6. Install windshield wiper and linkage assembly. Refer to [WW-27, "INSTALLATION"](#).

A  
B  
C  
D  
E  
BRC  
G  
H  
I  
J  
K

## ACTUATOR AND ELECTRIC UNIT (ASSEMBLY)

[TCS/ABS]

---

7. Reconnect battery cable.
8. Evacuate and recharge the A/C system. Refer to [ATC-116, "HFC-134a \(R-134a\) Service Procedure"](#) .

**PRECAUTIONS**

PF0:00001

**Precautions for Supplemental Restraint System (SRS) “AIR BAG” and “SEAT BELT PRE-TENSIONER”**

EFS002V3

The Supplemental Restraint System such as “AIR BAG” and “SEAT BELT PRE-TENSIONER”, used along with a front seat belt, helps to reduce the risk or severity of injury to the driver and front passenger for certain types of collision. Information necessary to service the system safely is included in the SRS and SB section of this Service Manual.

**WARNING:**

- To avoid rendering the SRS inoperative, which could increase the risk of personal injury or death in the event of a collision which would result in air bag inflation, all maintenance must be performed by an authorized NISSAN/INFINITI dealer.
- Improper maintenance, including incorrect removal and installation of the SRS, can lead to personal injury caused by unintentional activation of the system. For removal of Spiral Cable and Air Bag Module, see the SRS section.
- Do not use electrical test equipment on any circuit related to the SRS unless instructed to in this Service Manual. SRS wiring harnesses can be identified by yellow and/or orange harnesses or harness connectors.

**Precautions for Brake System**

EFS002V4

**CAUTION:**

- Recommended fluid is brake fluid “DOT 3”.
- Never reuse drained brake fluid.
- Be careful not to splash brake fluid on painted areas; it may cause paint damage. If brake fluid is splashed on painted areas, wash it away with water immediately.
- To clean or wash all parts of master cylinder and disc brake caliper, use clean brake fluid.
- Never use mineral oils such as gasoline or kerosene. They will ruin rubber parts of the hydraulic system.
- Use flare nut wrench when removing and installing brake tube.
- If a brake fluid leak is found, the part must be disassembled without fail. Then it has to be replaced with a new one if a defect exists.
- Turn the ignition switch OFF and remove the connector of the ABS actuator control unit or the battery terminal before performing the work.
- Always torque brake lines when installing.
- Burnish the brake contact surfaces after refinishing or replacing rotors, after replacing pads, or if a soft pedal occurs at very low mileage.

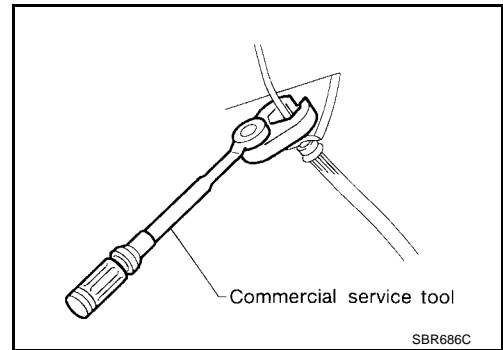

Refer to [BR-28, "Brake Burnishing"](#) (front disc brake) or [BR-35, "Brake Burnishing"](#) (rear disc brake).

**WARNING:**

- Clean brake pads and shoes with a waste cloth, then wipe with a dust collector.

**Precautions When Using CONSULT-II**

EFS0031Q

When connecting CONSULT-II to data link connector, connect them through CONSULT-II CONVERTER.

**CAUTION:**

If CONSULT-II is used with no connection of CONSULT-II CONVERTER, malfunctions might be detected in self-diagnosis depending on control unit which carry out CAN communication.

**CHECK POINTS FOR USING CONSULT-II**

1. Has CONSULT-II been used without connecting CONSULT-II CONVERTER on this vehicle?
  - If YES, GO TO 2.
  - If NO, GO TO 5.

# PRECAUTIONS

[VDC/TCS/ABS]

2. Is there any indication other than indications relating to CAN communication system in the self-diagnosis results?
  - If YES, GO TO 3.
  - If NO, GO TO 4.
3. Based on self-diagnosis results unrelated to CAN communication, carry out the inspection.
4. Malfunctions may be detected in self-diagnosis depending on control units carrying out CAN communication. Therefore, erase the self-diagnosis results.
5. Diagnose CAN communication system. Refer to [LAN-8, "CAN COMMUNICATION"](#).

## Precautions for Brake Control

EFS002V5

- During ABS operation, the brake pedal may vibrate lightly and a mechanical noise may be heard. This is normal.
- Just after starting vehicle, the brake pedal may vibrate or a motor operating noise may be heard from engine compartment. This is a normal status of operation check.
- Stopping distance may be longer than that of vehicles without ABS when vehicle drives on rough, gravel, or snow-covered (fresh, deep snow) roads.
- When an error is indicated by ABS or another warning lamp, collect all necessary information from customer (what symptoms are present under what conditions) and check for simple causes before starting diagnosis. Besides electrical system inspection, check booster operation, brake fluid level, and fluid leaks.
- If incorrect tire sizes or types are installed on the vehicle or brake pads are not Genuine NISSAN parts, stopping distance or steering stability may deteriorate.
- If there is a radio, antenna or related wiring near control module, ABS function may have a malfunction or error.
- If aftermarket parts (car stereo, CD player, etc.) have been installed, check for incidents such as harness pinches, open circuits or improper wiring.
- If the following components are replaced with non-genuine components or modified, the VDC OFF indicator lamp and SLIP indicator lamp may turn on or the VDC system may not operate properly. Components related to suspension (shock absorbers, struts, springs, bushings, etc.), tires, wheels (exclude specified size), components related to brake system (pads, rotors, calipers, etc.), components related to engine (muffler, ECM, etc.), components related to body reinforcement (roll bar, tower bar, etc.).
- Driving with broken or excessively worn suspension components, tires or brake system components may cause the VDC OFF indicator lamp and the SLIP indicator lamp to turn on, and the VDC system may not operate properly.
- When the TCS or VDC is activated by sudden acceleration or sudden turn, some noise may occur. The noise is a result of the normal operation of the TCS and VDC.
- When driving on roads which have extreme slopes (such as mountainous roads) or high banks (such as sharp curves on a freeway), the VDC may not operate normally, or the VDC warning lamp and the SLIP indicator lamp may turn on. This is not a problem if normal operation can be resumed after restarting the engine.
- Sudden turns (such as spin turns, acceleration turns), drifting, etc. with VDC turned off may cause the yaw rate/side G sensor to indicate a problem. This is not a problem if normal operation can be resumed after restarting the engine.

## Precautions for CAN System

EFS002V6

- Do not apply voltage of 7.0V or higher to terminal to be measured.
- Maximum open terminal voltage of tester in use must be less than 7.0V.
- Before checking harnesses, turn ignition switch OFF and disconnect battery negative cable.



# PRECAUTIONS

[VDC/TCS/ABS]

- Area to be repaired must be soldered and wrapped with tape. Make sure that fraying of twisted wire is within 110 mm (4.33 in).

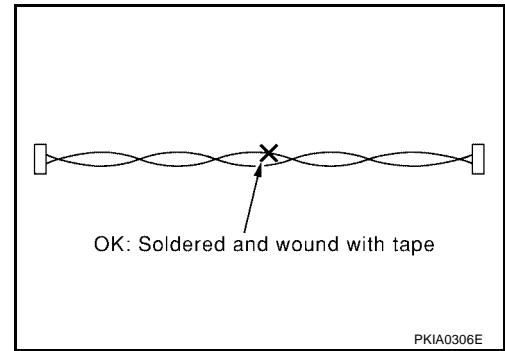

- Do not make a bypass connection to repaired area. (If the circuit is bypassed, characteristics of twisted wire will be lost.)

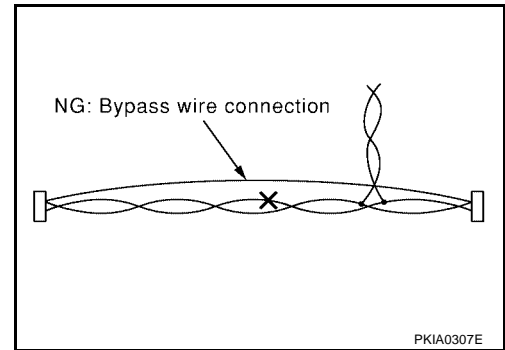

## Wiring Diagrams and Trouble Diagnosis

EFS002V7

When you read wiring diagrams, refer to the following:

- [GI-12, "How to Read Wiring Diagrams"](#)
- [PG-3, "POWER SUPPLY ROUTING CIRCUIT"](#)

When you perform trouble diagnosis, refer to the following:

- [GI-10, "HOW TO FOLLOW TEST GROUPS IN TROUBLE DIAGNOSES"](#)
- [GI-25, "How to Perform Efficient Diagnosis for an Electrical Incident"](#)

A  
B  
C  
D  
E  
BRC  
G  
H  
I  
J  
K  
L  
M

# PREPARATION

[VDC/TCS/ABS]

## PREPARATION

PFP:00002

### Special Service Tool

EFS002V8

The actual shapes of Kent-Moore tools may differ from those of special service tools illustrated here.

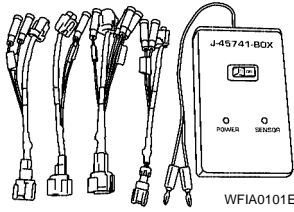
Tool number (Kent-Moore No.) Tool name	Description
<p>(J-45741) ABS active wheel sensor tester</p>  <p style="text-align: right;">WFIA0101E</p>	<p>Checking operation of ABS active wheel sensor</p>

### Commercial Service Tools

EFS002TE

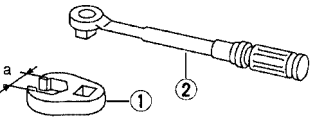
Tool name	Description
<p>1. Flare nut crowfoot a: 10mm (0.39 in)/12mm (0.47 in) 2. Torque wrench</p>  <p style="text-align: right;">S-NT360</p>	<p>Removing and installing brake piping</p>

SYSTEM DESCRIPTION

System Components

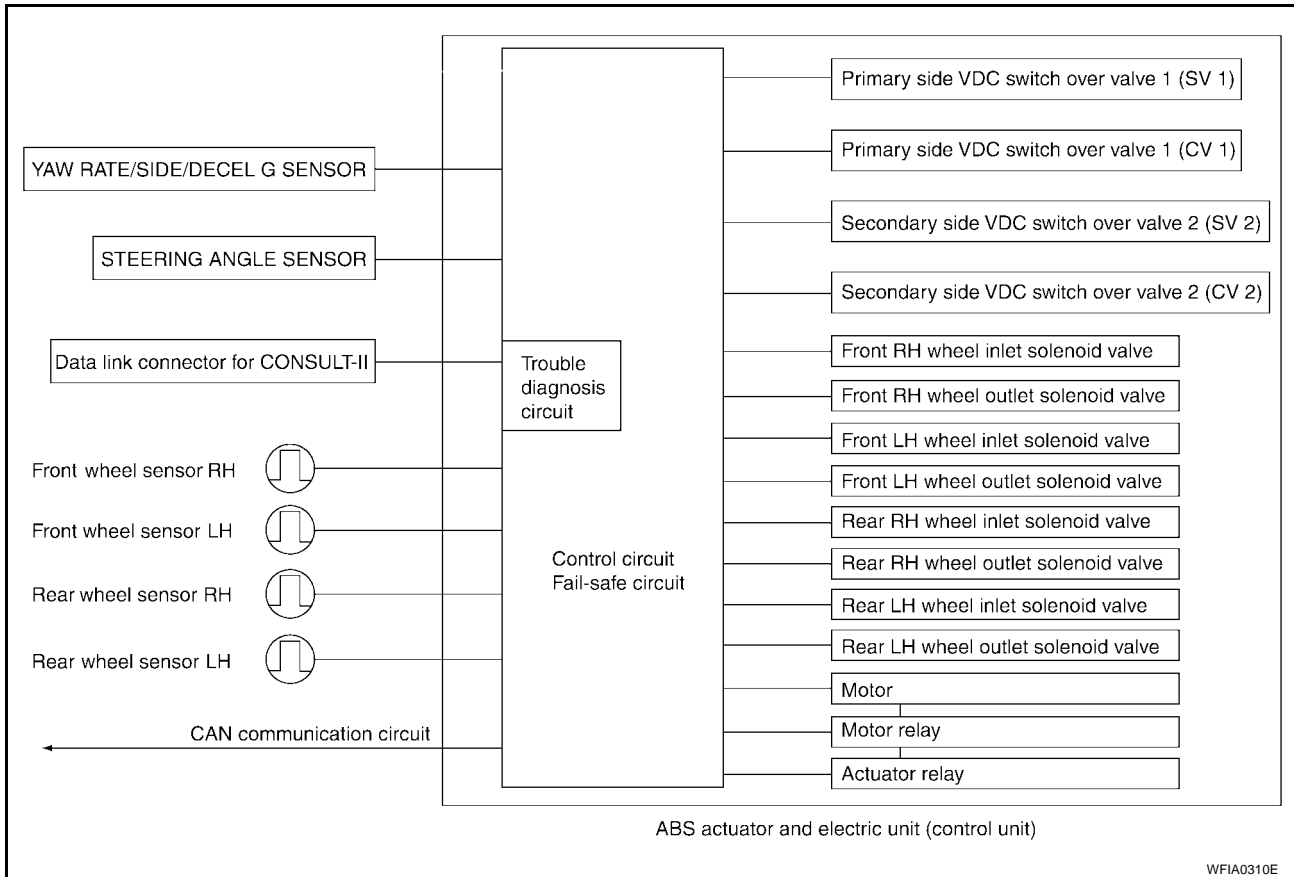

A

B

C

D

E

**BRC**

G

H

I

J

ABS Function

- The Anti-Lock Brake System detects wheel revolution while braking and improves handling stability during sudden braking by electrically preventing wheel lockup. Maneuverability is also improved for avoiding obstacles.
- If the electrical system malfunctions, the Fail-Safe function is activated, the ABS becomes inoperative and the ABS warning lamp turns on.
- The electrical system can be diagnosed using CONSULT-II.
- During ABS operation, the brake pedal may vibrate lightly and a mechanical noise may be heard. This is normal.
- Just after starting the vehicle, the brake pedal may vibrate or a motor operating noise may be heard from engine compartment. This is a normal status of operation check.
- Stopping distance may be longer than that of vehicles without ABS when vehicle drives on rough, gravel, or snow-covered (fresh, deep snow) roads.

K

L

M

EBD Function

- Electronic Brake Distribution is a function that detects subtle slippages between the front and rear wheels during braking, and it improves handling stability by electronically controlling the brake fluid pressure which results in reduced rear wheel slippage.
- If the electrical system malfunctions, the Fail-Safe function is activated, the EBD and ABS become inoperative, and the ABS warning lamp and BRAKE warning lamp are turned on.
- The electrical system can be diagnosed using CONSULT-II.
- During EBD operation, the brake pedal may vibrate lightly and a mechanical noise may be heard. This is normal.
- Just after starting the vehicle, the brake pedal may vibrate or a motor operating noise may be heard from engine compartment. This is a normal status of operation check.

- Stopping distance may be longer than that of vehicles without EBD when vehicle drives on rough, gravel, or snow-covered (fresh, deep snow) roads.

### TCS Function

EFS002TK

- Spinning of the drive wheels is detected by the ABS/TCS/VDC control unit using inputs from the wheel speed sensors. If wheel spin occurs, the drive wheel right and left brake fluid pressure control and engine fuel cut are conducted while the throttle value is restricted to reduce the engine torque and decrease the amount of wheel spin. In addition, the throttle opening is controlled to achieve the optimum engine torque.
- Depending on road condition, the vehicle may have a sluggish feel. This is normal, because optimum traction has the highest priority during TCS operation.
- TCS may be activated during sudden vehicle acceleration, wide open throttle acceleration, sudden transmission shifts or when the vehicle is driven on a road with a varying surface friction coefficient.
- The SLIP indicator lamp flashes to inform the driver of TCS operation.

### VDC Function

EFS002TJ

- In addition to the ABS/TCS function, the driver steering amount and brake operation amount are detected from the steering angle sensor, and the vehicle's driving status (amount of under steering/over steering) is determined using inputs from the yaw rate sensor/side G sensor, wheel speed sensors, etc. and this information is used to improve vehicle stability by controlling the braking and engine torque application to the wheels.
- The SLIP indicator lamp flashes to inform the driver of VDC operation.
- During VDC operation, the vehicle body and brake pedal may vibrate lightly and a mechanical noise may be heard. This is normal.
- The ABS warning lamp, VDC OFF indicator lamp and SLIP indicator lamp may turn on when the vehicle is subject to strong shaking or large vibration, such as when the vehicle is on a turn table or a ship while the engine is running or steep slope. In this case, restart the engine on a normal road and if the ABS warning lamp, VDC OFF indicator lamp and SLIP indicator lamp turn off, there is no problem.

### Wheel Sensors

The front sensor units consist of a gear-shaped sensor rotor and a sensor element. The element contains a magnet around which a coil is wound. The front wheel sensors are installed on the front of the wheel knuckles. As the wheel rotates, the sensor generates a square-wave signal. The frequency increases as the wheel speed increases.

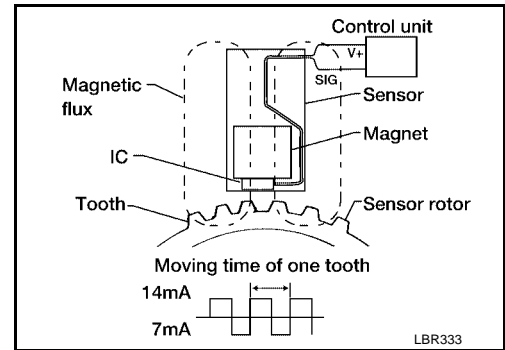

The rear sensor units consist of wheel hubs with a series of internal magnets and a sensor element. The rear wheel sensors are installed on the inner side of the wheel knuckles. As the wheel rotates, the sensor generates a square-wave signal. The frequency increases as the wheel speed increases.

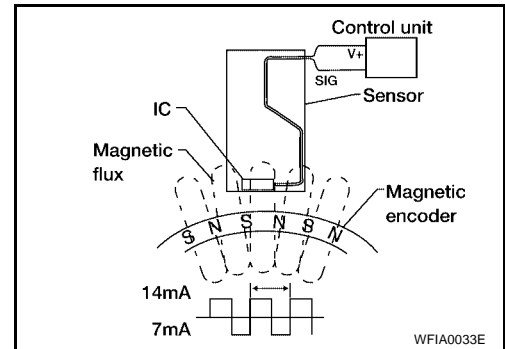

### Fail-Safe Function ABS/EBD SYSTEM

In case of an electrical malfunction with the ABS, the ABS warning lamp, VDC OFF indicator lamp and SLIP indicator lamp will turn on. In case of an electrical malfunction with the EBD system, the BRAKE warning lamp, ABS warning lamp, VDC OFF indicator lamp and SLIP indicator lamp will turn on.

The system will revert to one of the following conditions of the Fail-Safe function.

1. For ABS malfunction, only the EBD is operative and the condition of the vehicle is the same condition of vehicles without ABS/TCS/VDC system.
2. For EBD malfunction, the EBD and ABS become inoperative, and the condition of the vehicle is the same as the condition of vehicles without ABS/TCS/VDC or EBD system.

### VDC/TCS SYSTEM

In case of TCS/VDC system malfunction, the VDC OFF indicator lamp and SLIP indicator lamp are turned on and the condition of the vehicle is the same as the condition of vehicles without TCS/VDC system. In case of an electrical malfunction with the TCS/VDC system, the ABS control continues to operate normally without TCS/VDC control.

#### **CAUTION:**

**If the Fail-Safe function is activated, perform the Self Diagnosis for ABS/TCS/VDC system.**

A  
B  
C  
D  
E  
BRC  
G  
H  
I  
J  
K  
L  
M

# SYSTEM DESCRIPTION

[VDC/TCS/ABS]

## Hydraulic Circuit Diagram

EFS002T0

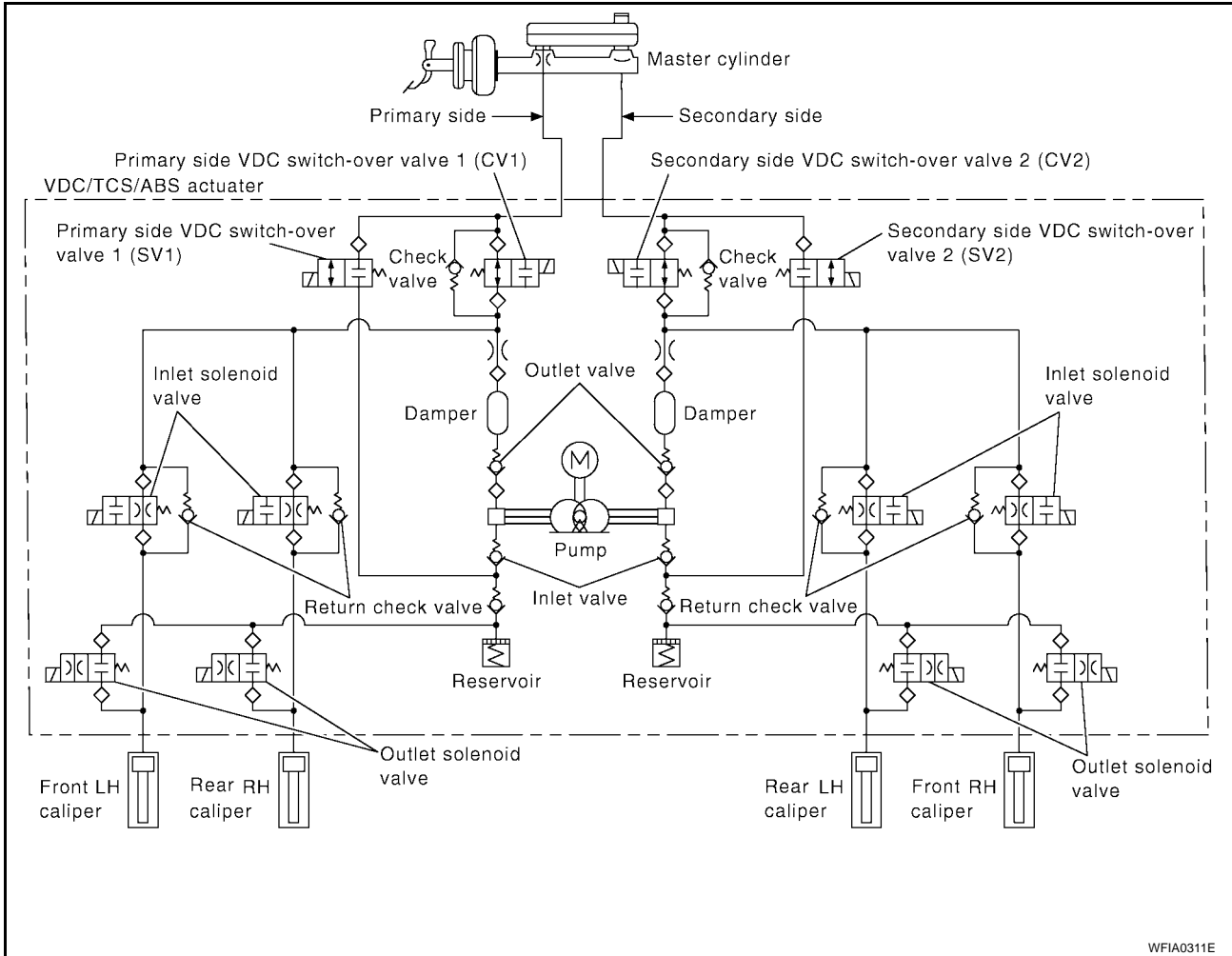

---

**CAN COMMUNICATION**

PFP:23710

**System Description**

EFS00315

Refer to [LAN-8, "CAN COMMUNICATION"](#) .

A

B

C

D

E

**BRC**

G

H

I

J

K

L

M

**TROUBLE DIAGNOSIS****How to Perform Trouble Diagnoses for Quick and Accurate Repair**  
**INTRODUCTION**

EFS002XX

The ABS/TCS/VDC system has an electronic control unit to control major functions. The control unit accepts input signals from sensors and controls actuator operation. It is also important to check for conventional problems such as air leaks in the booster or lines, lack of brake fluid, or other problems with the brake system.

It is much more difficult to diagnose a problem that occurs intermittently rather than continuously. Most intermittent problems are caused by poor electrical connections or faulty wiring. In this case, careful checking of suspicious circuits may help prevent the replacement of good parts.

A visual check only may not find the cause of the problem, so a road test should be performed.

Before undertaking actual checks, take just a few minutes to talk with a customer who approaches with an ABS/TCS/VDC complaint. The customer is a very good source of information on such problems, especially intermittent ones. Through the talks with the customer, find out what symptoms are present and under what conditions they occur.

Start your diagnosis by looking for "conventional" problems first. This is one of the best ways to troubleshoot brake problems on an ABS/TCS/VDC equipped vehicle. Also check related Service Bulletins for information.

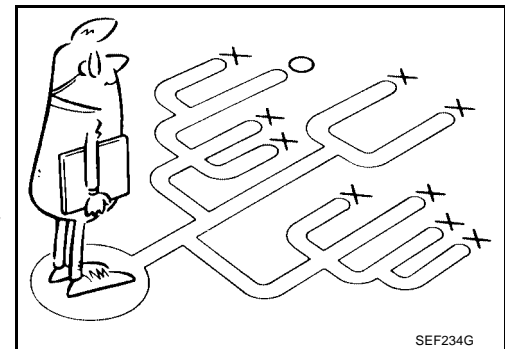
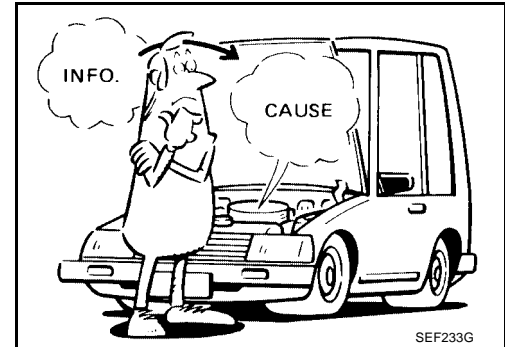



# TROUBLE DIAGNOSIS

[VDC/TCS/ABS]

## WORK FLOW

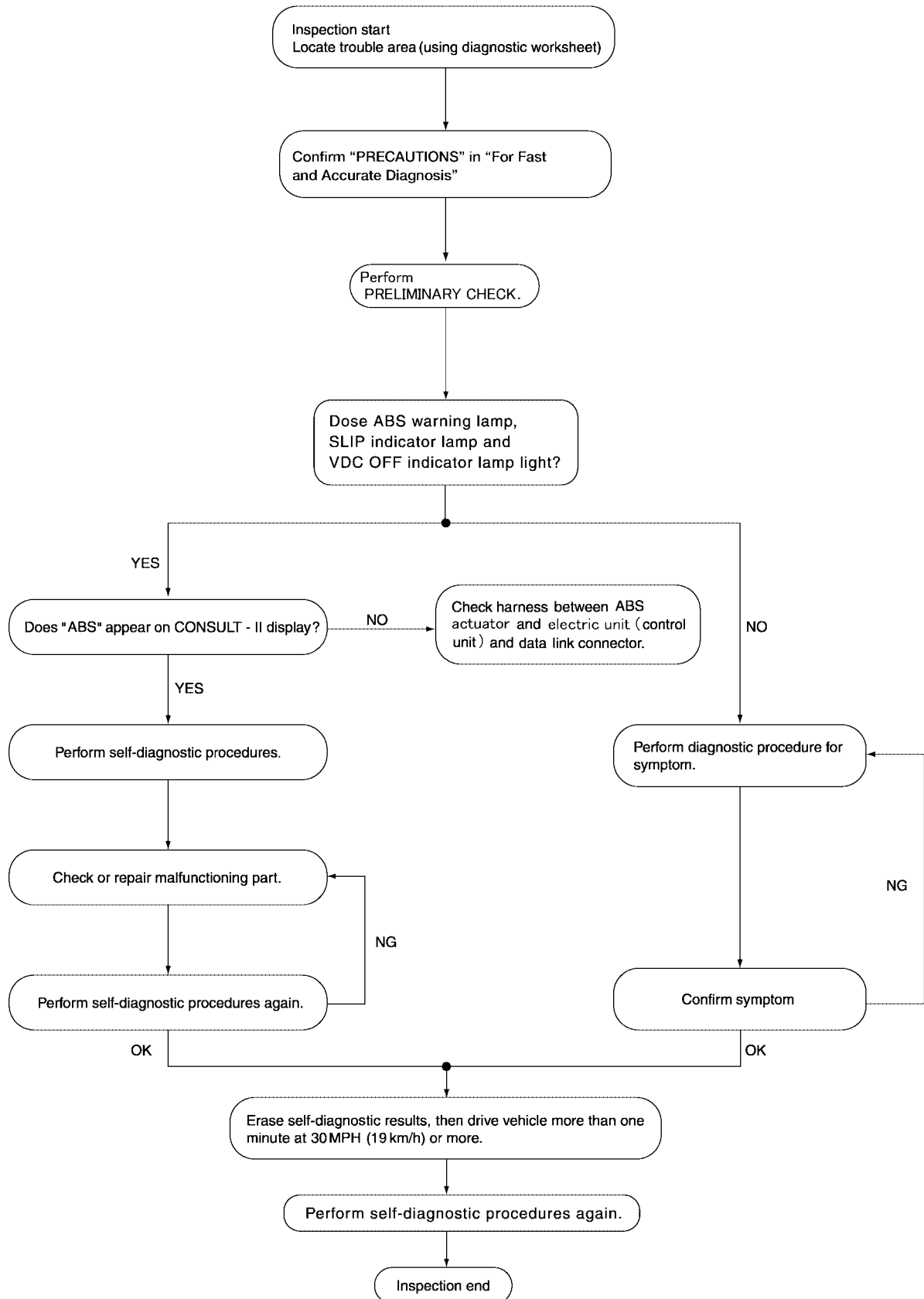

A  
B  
C  
D  
E  
BRC  
G  
H  
I  
J  
K  
L  
M

PFA0464E

# TROUBLE DIAGNOSIS

[VDC/TCS/ABS]

## CLARIFY CONCERN

- A customer's description of a vehicle concern may vary depending on the individual. It is important to clarify the customer's concern.
- Ask the customer about what symptoms are present under what conditions. Use this information to reproduce the symptom while driving.
- It is also important to use the diagnosis sheet to understand what type of trouble the customer is having.

**KEY POINTS**

**WHAT** ..... Vehicle model  
**WHEN** ..... Date, Frequencies  
**WHERE** ..... Road conditions  
**HOW** ..... Operating conditions,  
 Weather conditions,  
 Symptoms

SBR339B

## EXAMPLE OF DIAGNOSIS SHEET

Customer name	Model & Year	VIN	
Engine #	Trans.	Mileage	
Incident Date	Manuf. Date	In Service Date	
Symptoms	<input type="checkbox"/> Noise and vibration (from engine compartment)	<input type="checkbox"/> ABS warning lamp activates	<input type="checkbox"/> Pedal operation
	<input type="checkbox"/> Noise and vibration (from axle)	<input type="checkbox"/> SLIP warning lamp activates	<input type="checkbox"/> Large stroke pedal operation
	<input type="checkbox"/> TCS does not work (drive wheels slip when accelerating)	<input type="checkbox"/> ABS does not work (wheels slip when braking)	<input type="checkbox"/> Firm pedal
Engine conditions	<input type="checkbox"/> When starting <input type="checkbox"/> After starting		
Road conditions	<input type="checkbox"/> Low friction road ( <input type="checkbox"/> Snow <input type="checkbox"/> Gravel <input type="checkbox"/> Other ) <input type="checkbox"/> Bumps/potholes		
Driving conditions	<input type="checkbox"/> Full-acceleration <input type="checkbox"/> High speed cornering <input type="checkbox"/> Vehicle speed: Greater than 10 km/h (6 MPH) <input type="checkbox"/> Vehicle speed: 10 km/h (6 MPH) or less <input type="checkbox"/> Vehicle is stopped		
Applying brake conditions	<input type="checkbox"/> Suddenly <input type="checkbox"/> Gradually		
Other conditions	<input type="checkbox"/> Operation of electrical equipment <input type="checkbox"/> Shift change <input type="checkbox"/> Other descriptions		

WFIA0097E

# TROUBLE DIAGNOSIS

[VDC/TCS/ABS]

## Component Parts and Harness Connector Location

EFS002XY

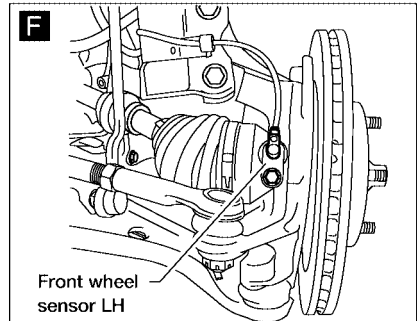
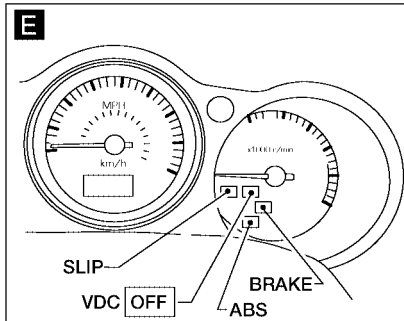
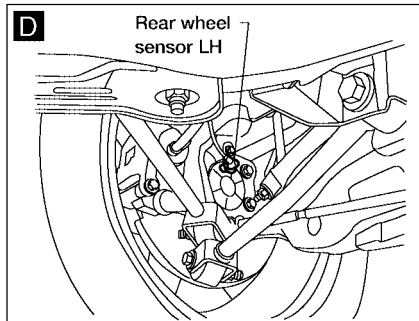
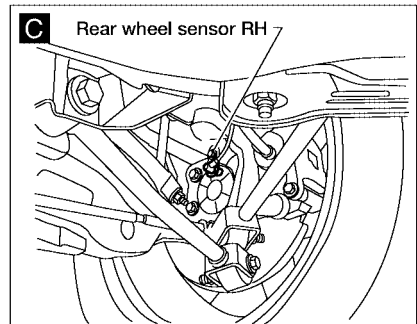
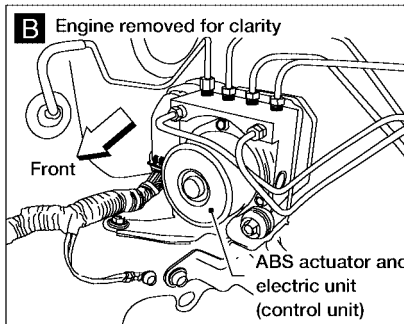
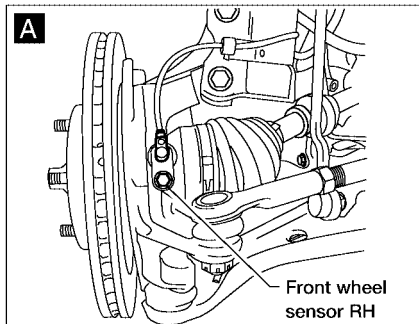
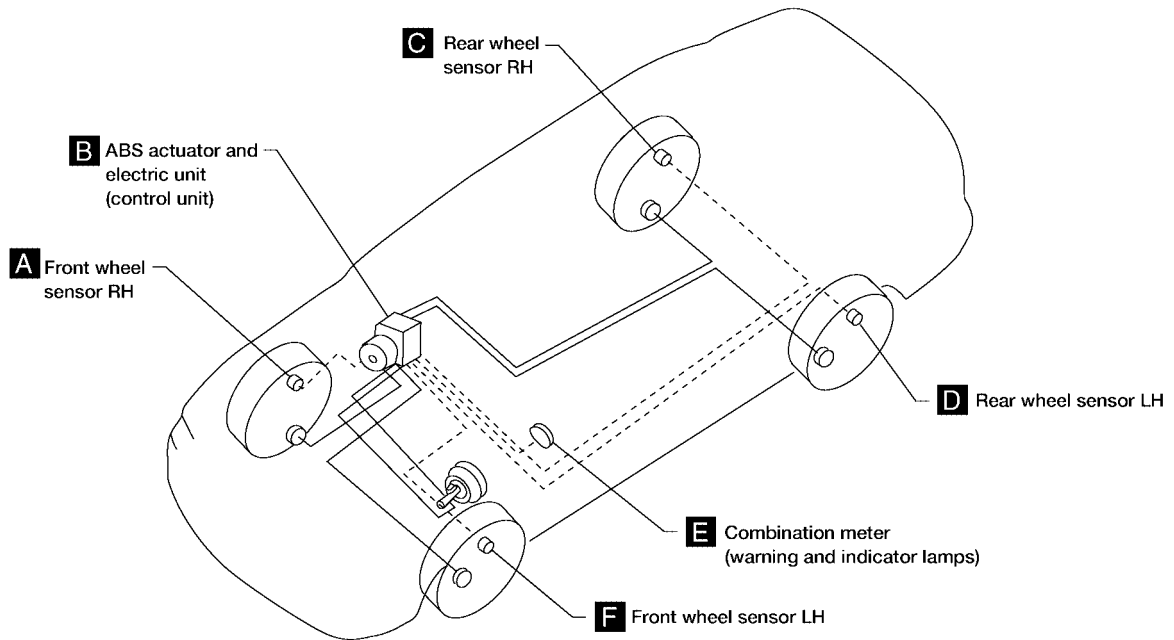

A  
B  
C  
D  
E  
BRC  
G  
H  
I  
J  
K  
L  
M

WFIA0100E

### Schematic

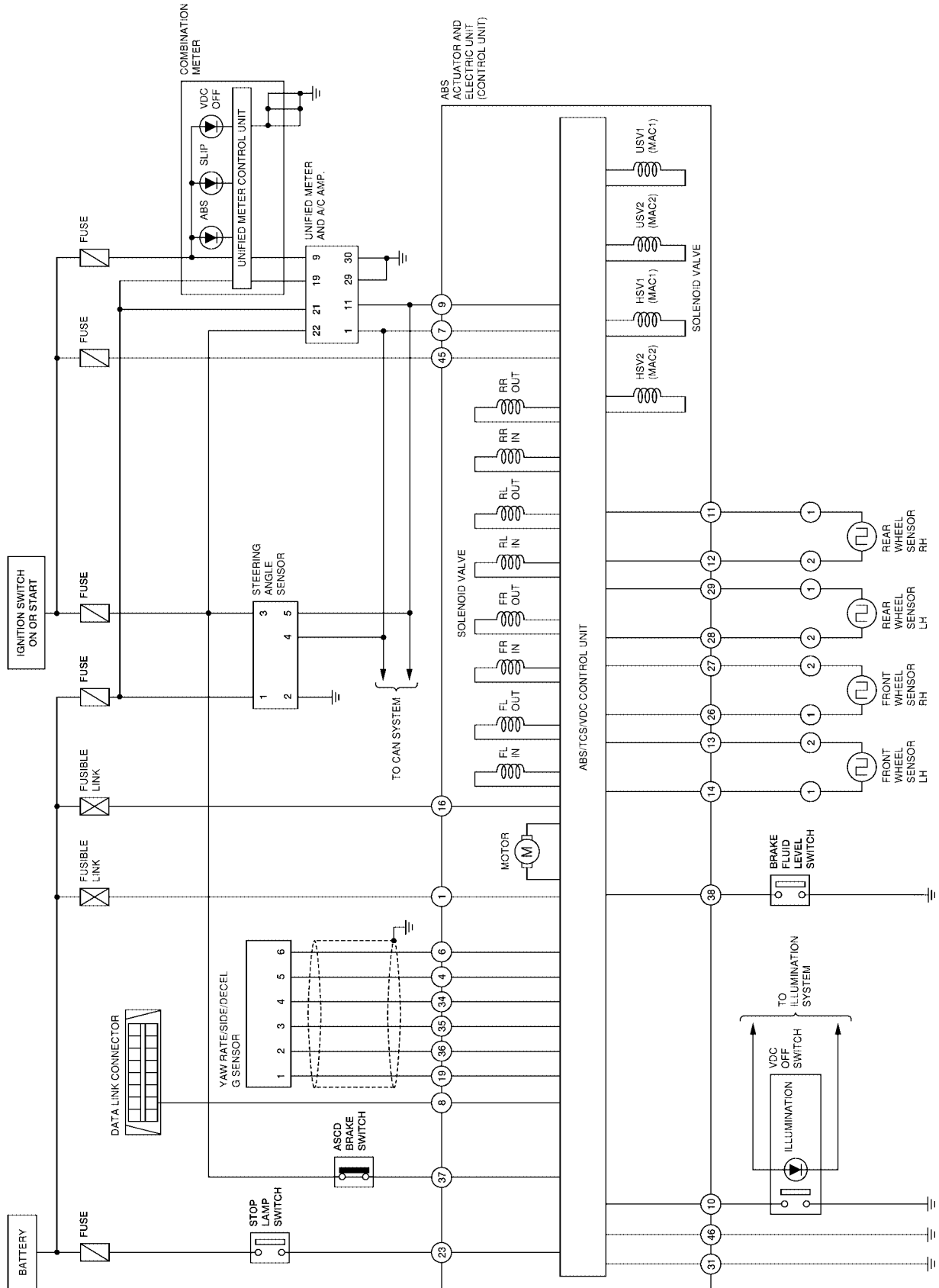

# TROUBLE DIAGNOSIS

[VDC/TCS/ABS]

## Wiring Diagram — VDC —

EFS002Y0

BRC-VDC-01

A  
B  
C  
D  
E  
BRC  
G  
H  
I  
J  
K  
L  
M

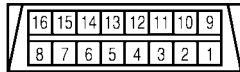
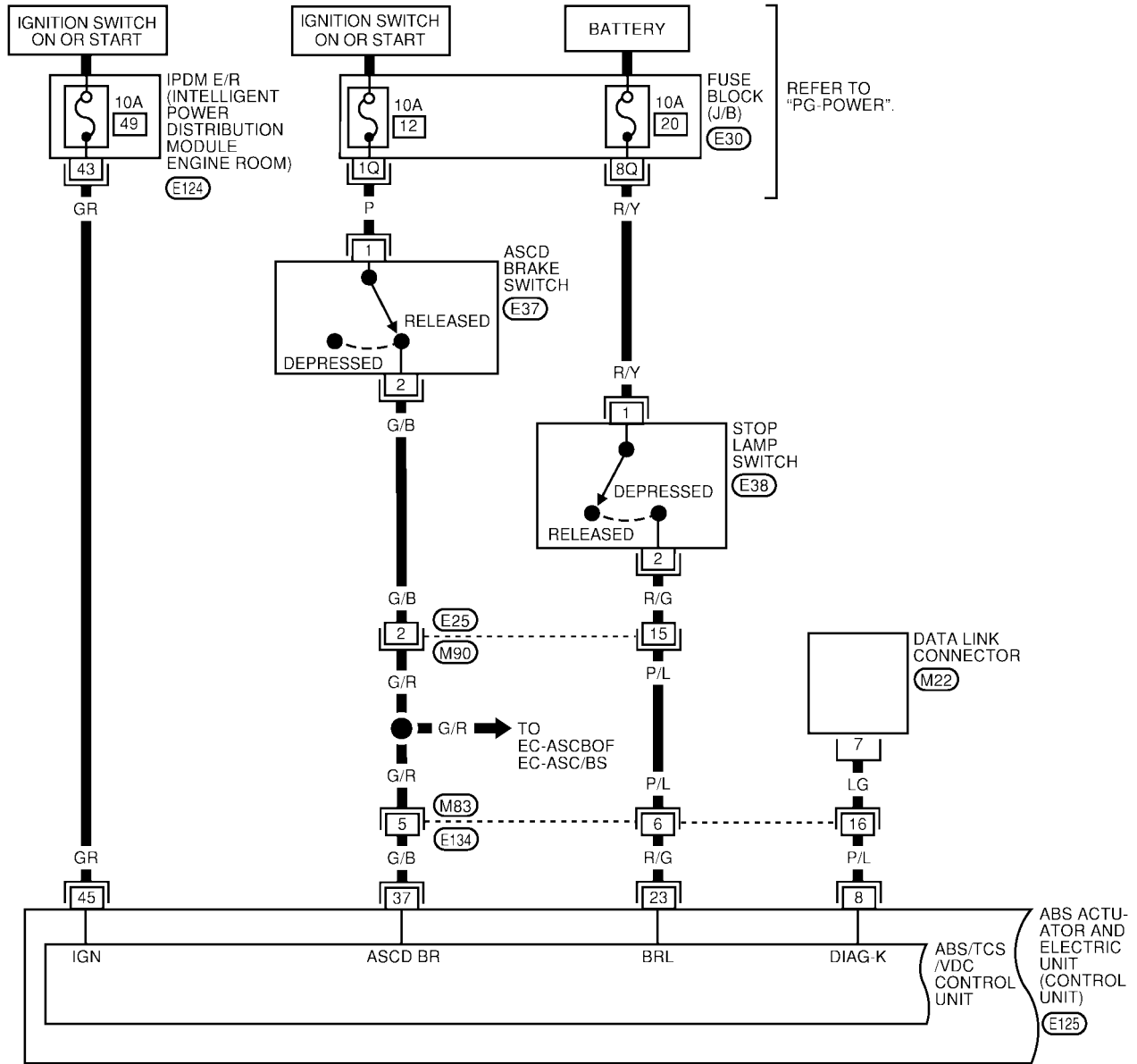

(M22) W

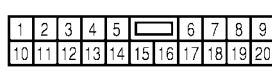

(M83) W

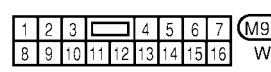

(M90) W



(E37) BR



(E38) B

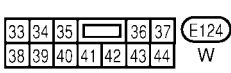

(E124) W

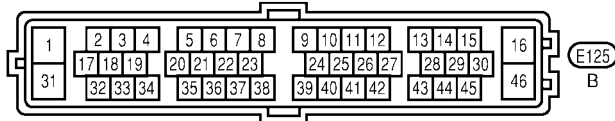

(E125) B

REFER TO THE FOLLOWING.

(E30) - FUSE BLOCK - JUNCTION BOX (J/B)

WFWA0028E

# TROUBLE DIAGNOSIS

[VDC/TCS/ABS]

BRC-VDC-02

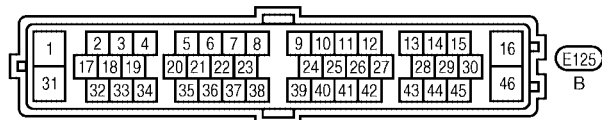
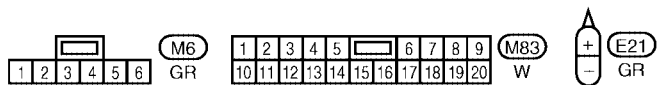
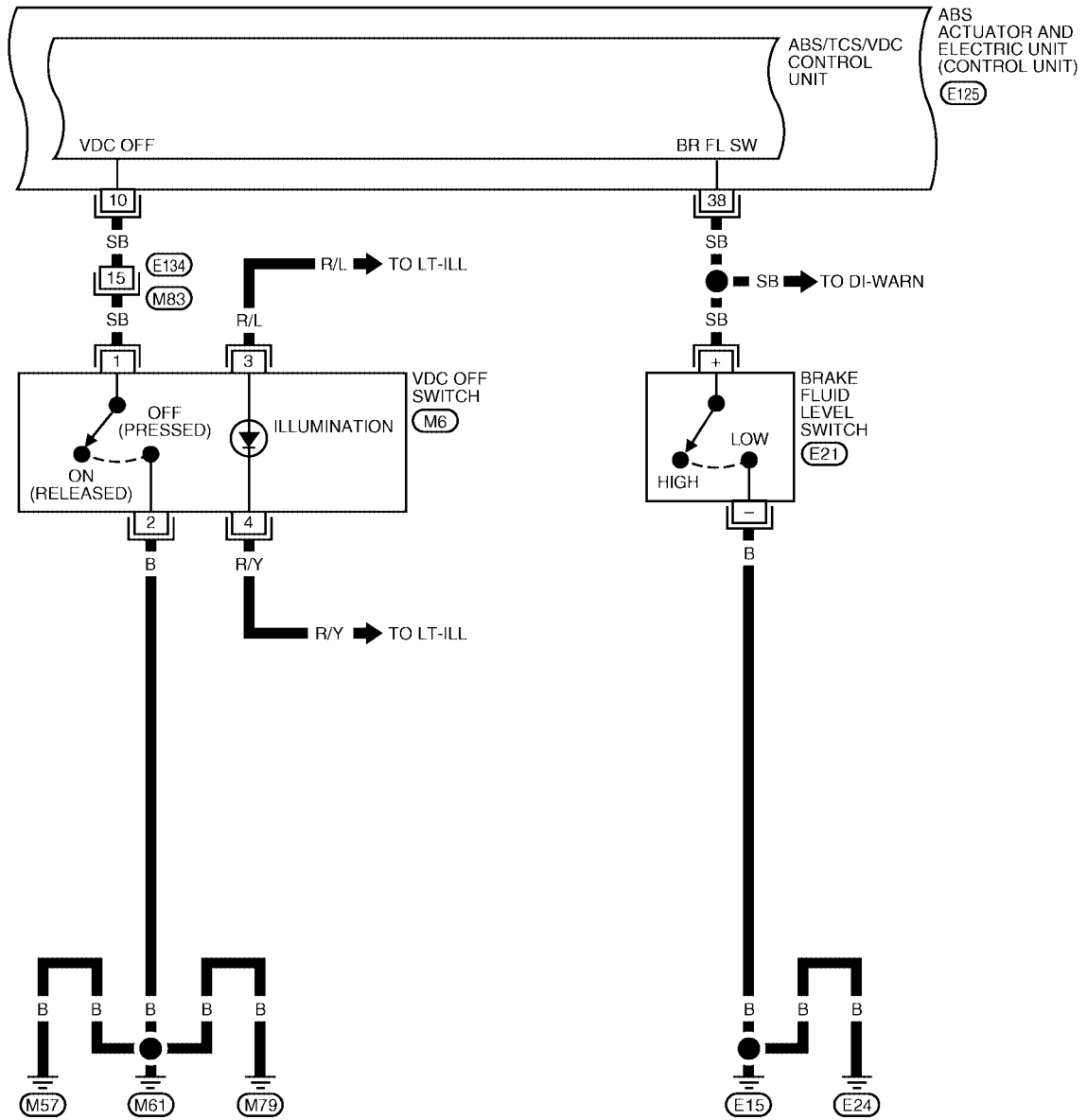

WFWA0029E

# TROUBLE DIAGNOSIS

[VDC/TCS/ABS]

## BRC-VDC-03

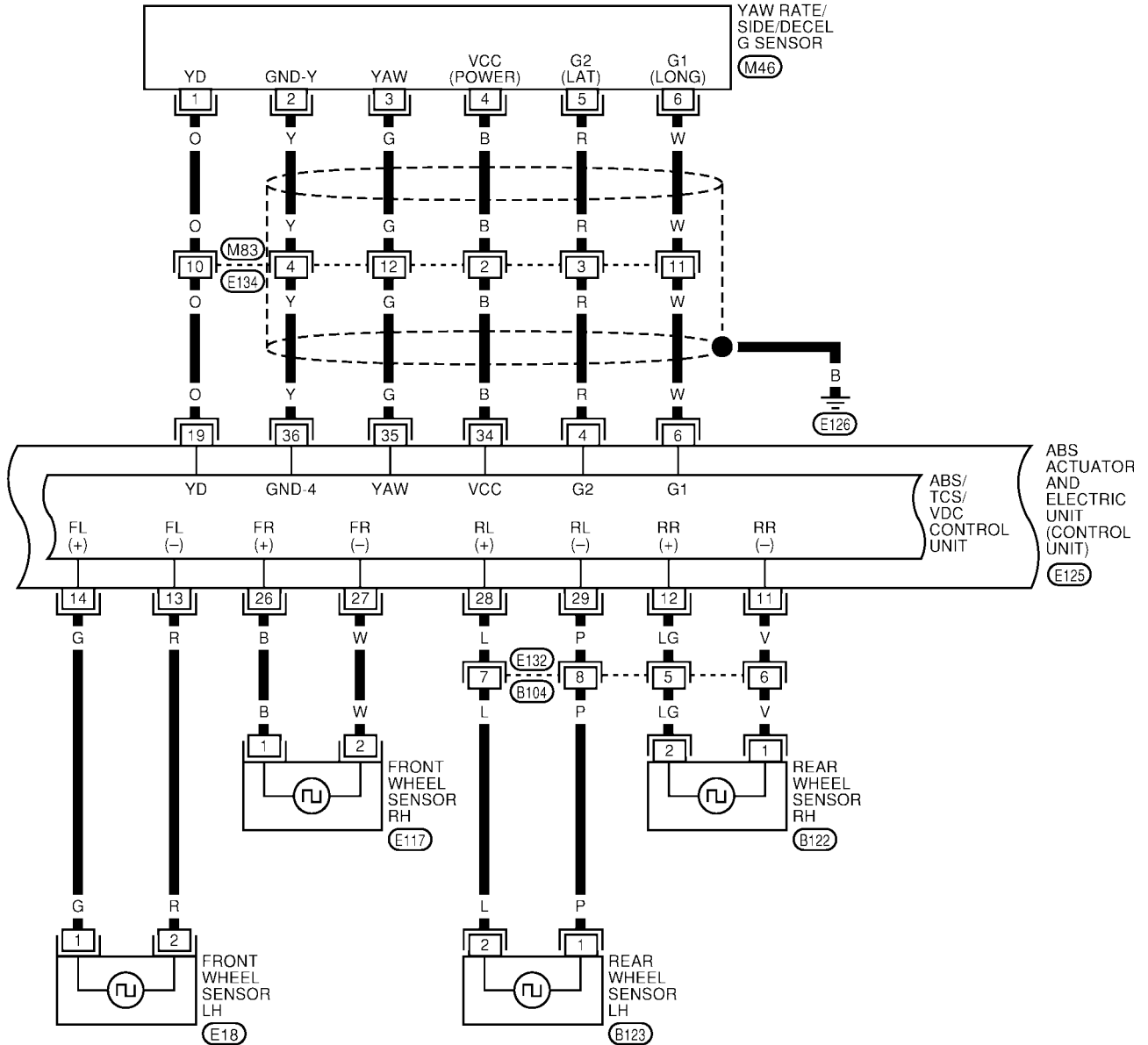

A  
B  
C  
D  
E  
**BRC**  
G  
H  
I  
J  
K  
L  
M

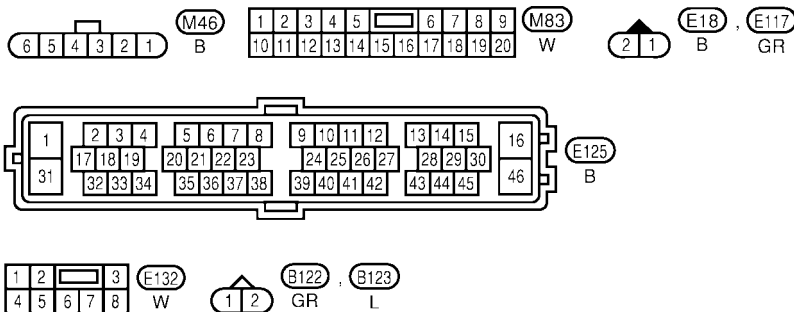

WFWA0030E

# TROUBLE DIAGNOSIS

[VDC/TCS/ABS]

BRC-VDC-04

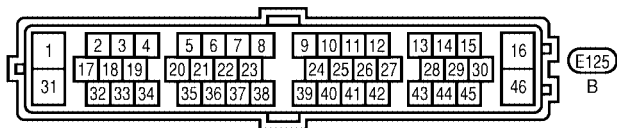
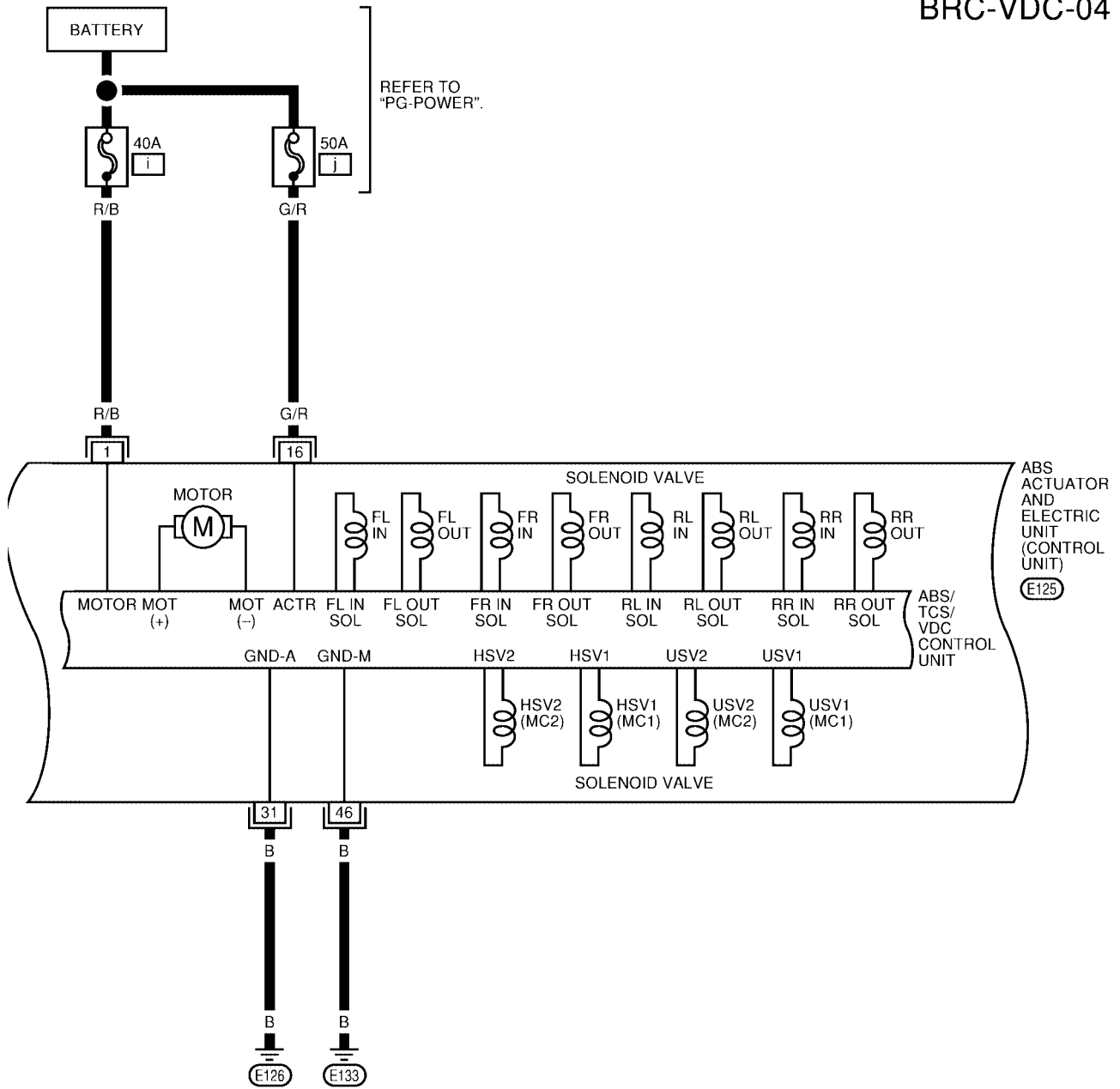

WFWA0031E



# TROUBLE DIAGNOSIS

[VDC/TCS/ABS]

BRC-VDC-05

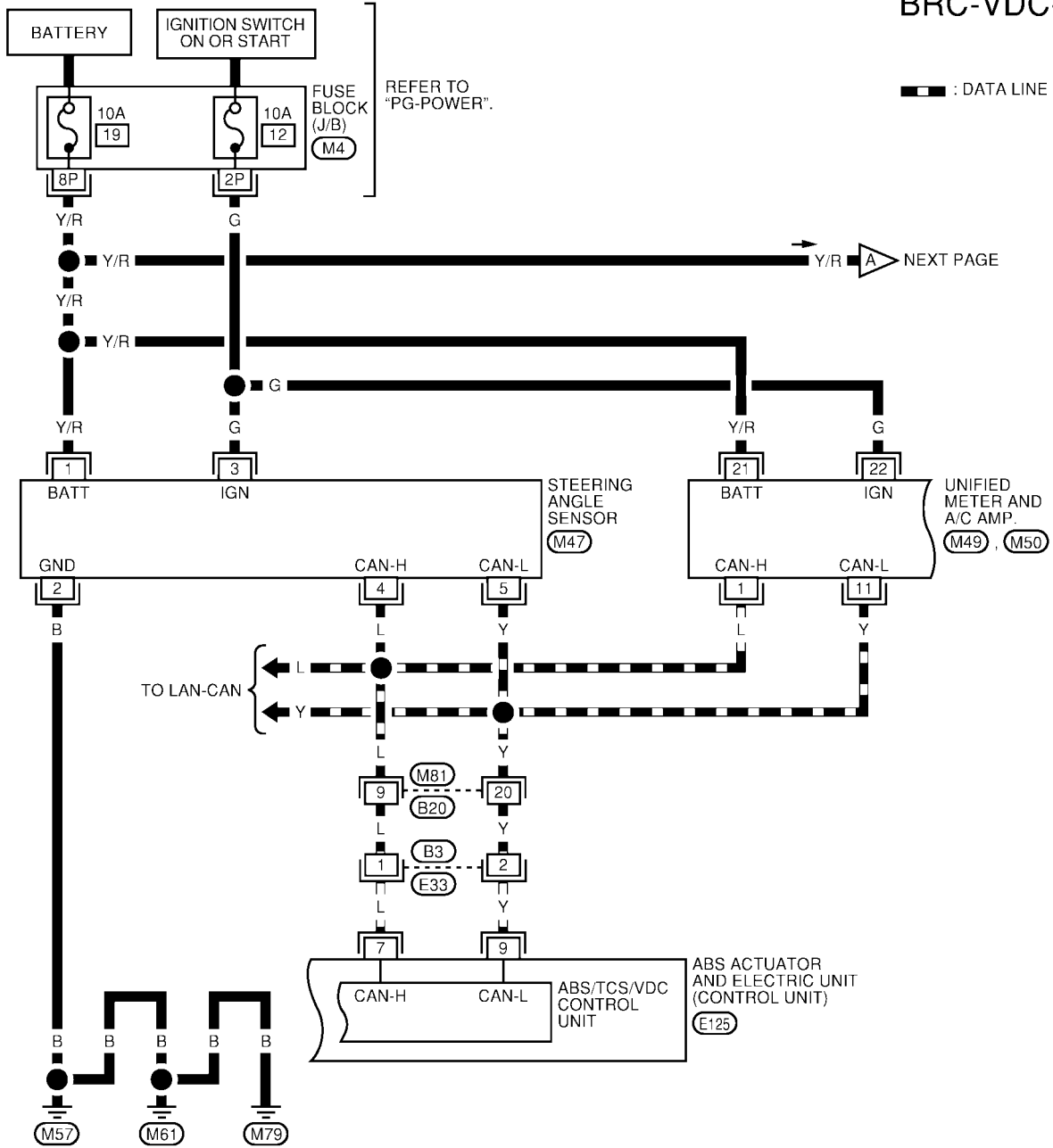

A  
B  
C  
D  
E  
BRC  
G  
H  
I  
J  
K  
L  
M

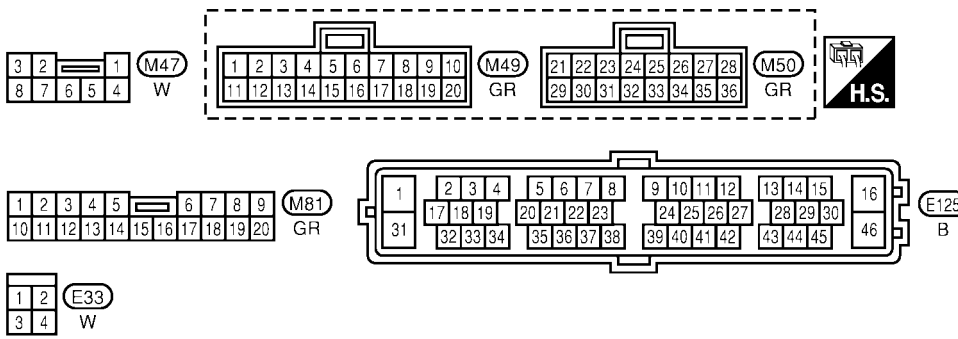

REFER TO THE FOLLOWING.  
 (M4) - FUSE BLOCK -  
 JUNCTION BOX (J/B)



WFWA0032E

# TROUBLE DIAGNOSIS

[VDC/TCS/ABS]

BRC-VDC-06

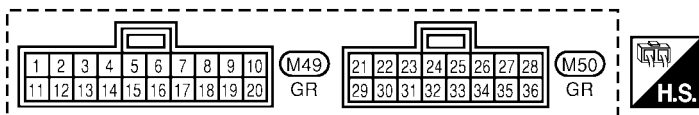
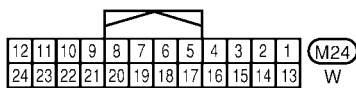
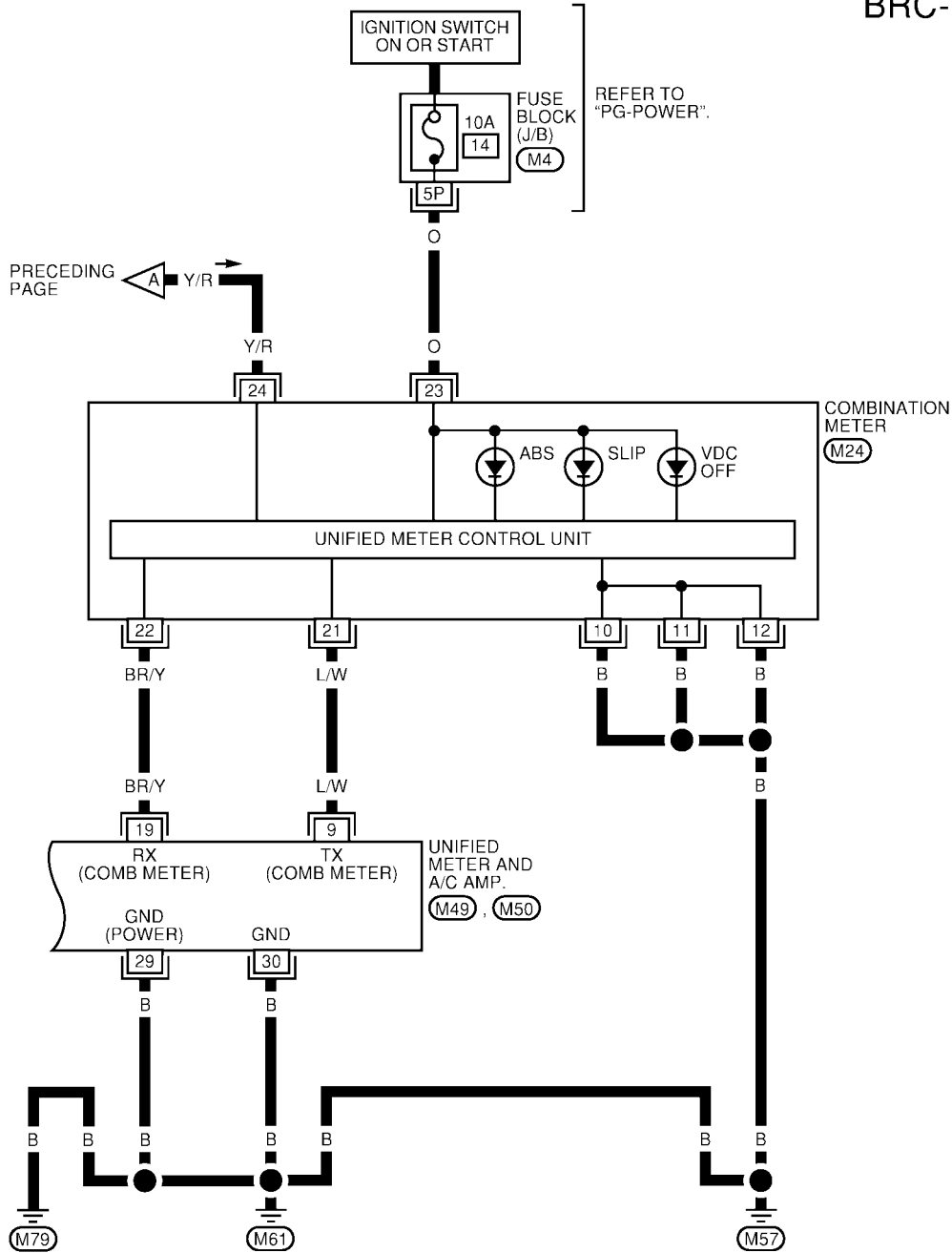

REFER TO THE FOLLOWING.

(M4) - FUSE BLOCK - JUNCTION BOX (J/B)

WFWA0033E

### Basic Inspection

#### BRAKE FLUID LEVEL, FLUID LEAK, AND BRAKE PAD INSPECTION

1. Check fluid level in the brake fluid reservoir. If fluid level is low, add fluid.
2. Check the brake piping and around the ABS actuator and electric unit (control unit) for leaks. If there is leaking or seeping fluid, check the following items.
  - If ABS actuator and electric unit (control unit) connection is loose, tighten the piping to the specified torque and recheck for leaks.
  - If there is damage to the connection flare nut or ABS actuator and electric unit (control unit) screw, replace the damaged part and recheck for leaks.
  - When there is fluid leaking or seeping from a fluid connection, use a clean cloth to wipe off the fluid and recheck for leaks. If fluid is still seeping out, replace the damaged part. If the fluid is leaking at the ABS actuator and electric unit (control unit), replace the ABS actuator and electric unit (control unit) assembly.

**CAUTION:**

**The ABS actuator and electric unit (control unit) cannot be disassembled and must be replaced as an assembly.**

3. Check the brake pads for excessive wear.

#### POWER SYSTEM TERMINAL LOOSENESS AND BATTERY INSPECTION

Make sure the battery positive cable, negative cable and ground connection are not loose. In addition, make sure the battery is sufficiently charged.

#### ABS WARNING LAMP, SLIP INDICATOR LAMP AND VDC OFF INDICATOR LAMP INSPECTION

1. Make sure ABS warning lamp, SLIP indicator lamp and VDC OFF indicator lamp (when VDC OFF switch is off), turn on for approximately 1 second when the ignition switch is turned ON. If they do not, check the VDC OFF indicator lamp and then VDC OFF switch. Refer to [BRC-129, "VDC OFF SWITCH"](#) . Check CAN communications. If there are no errors with VDC OFF switch and CAN communication system, check combination meter. Refer to [DI-5, "COMBINATION METERS"](#) .
2. Make sure the lamps turn off approximately 1 second after the ignition switch is turned ON. If the lamp does not turn off, conduct self-diagnosis.
3. With the engine running, make sure VDC OFF indicator lamp turns on and off when VDC OFF switch is turned on and off. If the indicator lamp status does not correspond to switch operation, check the VDC OFF switch system. Refer to [BRC-129, "VDC OFF SWITCH"](#) .
4. Make sure ABS warning lamp, SLIP indicator lamp and VDC OFF indicator lamp turn off approximately 2 seconds after the engine is started. If ABS warning lamp, SLIP indicator lamp or VDC OFF indicator lamp have not turned off 10 seconds after the engine has been started, conduct self-diagnosis of the ABS actuator and electric unit (control unit).
5. After conducting the self-diagnosis, be sure to erase the error memory. Refer to [BRC-111, "CONSULT-II Function \(ABS\)"](#) .

#### Warning Lamp and Indicator Timing

×: ON    -: Lamp OFF

Condition	ABS warning lamp	VDC OFF indicator lamp	SLIP indicator lamp	Remarks
When the ignition switch is OFF	-	-	-	-
After the ignition switch is turned ON For approx. 0.5 seconds	×	×	×	-
Ignition switch ON Approx. 0.5 seconds later	-	-	-	Lamp goes off approx. 2 seconds after the engine start.
When the VDC OFF switch turns ON (VDC function OFF).	-	×	-	-

# TROUBLE DIAGNOSIS

[VDC/TCS/ABS]

Condition	ABS warning lamp	VDC OFF indicator lamp	SLIP indicator lamp	Remarks
ABS/TCS/VDC malfunction	×	×	×	—
	×	×	—	When the ABS/TCS/VDC control unit is malfunctioning (power supply or ground malfunction).
When the VDC is malfunctioning.	—	×	×	—

## Control Unit Input/Output Signal Standard REFERENCE VALUE FROM CONSULT-II

EFS002Y2

### CAUTION:

The display shows the control unit calculation data, so a normal value might be displayed even in the event the output circuit (harness) is open or short circuited.

Monitor item	Display content	Data monitor		Note: Error inspection checklist
		Condition	Reference value in normal operation	
SLCT LVR POSI	PNP switch signal ON/OFF condition	A/T shift position = N or P position	ON	<a href="#">BRC-128, "CAN Communication System Inspection"</a>
		A/T shift position = other than N and P positions	OFF	
GEAR	A/T gear position	1:1st gear 2:2nd gear 3:3rd gear 4:4th gear	—	—
FR RH SENSOR FR LH SENSOR RR RH SENSOR RR LH SENSOR	Wheel speed	Vehicle stopped	0 [km/h (MPH)]	<a href="#">BRC-119, "Wheel Sensor System Inspection"</a>
		Vehicle running (Note 1)	Almost in accordance with speedometer display (within ±10%)	
ACCEL POS SIG	Open/close condition of throttle valve (linked with accelerator pedal).	Accelerator pedal not depressed (ignition switch is ON)	0%	<a href="#">BRC-128, "CAN Communication System Inspection"</a>
		Depress accelerator pedal (ignition switch is ON)	0 to 100%	
ENGINE SPEED.	With engine running	With engine stopped	0 rpm	<a href="#">BRC-120, "Engine System Inspection"</a>
		Engine running	Almost in accordance with tachometer display	
STR ANGLE SIG	Steering angle detected by steering angle sensor	Straight-ahead	Approx. 0 deg	<a href="#">BRC-121, "Steering Angle Sensor System Inspection"</a>
		Steering wheel turned	−756 to 756 deg	
YAW RATE SEN	Yaw rate detected by yaw rate sensor	Vehicle stopped	Approx. 0 d/s	<a href="#">BRC-122, "Yaw Rate/Side/Decel G Sensor System Inspection"</a>
		Vehicle running	−100 to 100 d/s	
SIDE G SENSOR	Transverse G detected by side G-sensor	Vehicle stopped	Approx. 0 m/s <sup>2</sup>	<a href="#">BRC-122, "Yaw Rate/Side/Decel G Sensor System Inspection"</a>
		Vehicle running	−16.7 to 16.7 m/s <sup>2</sup>	
BATTERY VOLT	Battery voltage supplied to ABS actuator and electric unit (control unit)	Ignition switch ON	10 to 16V	<a href="#">BRC-127, "ABS/TCS/VDC Control Unit Power and Ground Systems Inspection"</a>
STOP LAMP SW	Brake pedal operation	Brake pedal depressed	ON	<a href="#">BRC-126, "Stop Lamp Switch System Inspection"</a>
		Brake pedal not depressed	OFF	

# TROUBLE DIAGNOSIS

[VDC/TCS/ABS]

Monitor item	Display content	Data monitor		Note: Error inspection checklist
		Condition	Reference value in normal operation	
OFF SW	VDC OFF switch ON/OFF status	VDC OFF switch ON (When VDC OFF indicator lamp is ON)	ON	<a href="#">BRC-129, "VDC OFF SWITCH"</a>
		VDC OFF switch OFF (When VDC OFF indicator lamp is OFF)	OFF	
ABS WARN LAMP	ABS warning lamp ON condition (Note 2)	ABS warning lamp ON	ON	<a href="#">BRC-133, "ABS Warning Lamp Does Not Come On When Ignition Switch Is Turned On"</a>
		ABS warning lamp OFF	OFF	
MOTOR RELAY	Operation status of motor and motor relay	Ignition switch ON or engine running (ABS not operated)	OFF	<a href="#">BRC-125, "Actuator Motor, Motor Relay, and Circuit Inspection"</a>
		Ignition switch ON or engine running (ABS operated)	ON	
ACTUATOR RLY	Actuator relay operation status	Vehicle stopped (Ignition switch ON)	OFF	<a href="#">BRC-125, "Actuator Motor, Motor Relay, and Circuit Inspection"</a>
		Vehicle stopped (Engine running)	ON	
OFF LAMP	VDC OFF indicator lamp status (Note 3)	When VDC OFF indicator lamp is ON	ON	<a href="#">BRC-128, "CAN Communication System Inspection"</a>
		When VDC OFF indicator lamp is OFF	OFF	
SLIP LAMP	SLIP indicator lamp status (Note 4)	When SLIP indicator lamp is ON	ON	<a href="#">BRC-128, "CAN Communication System Inspection"</a>
		When SLIP indicator lamp is OFF	OFF	
FR LH IN SOL FR LH OUT SOL FR RH IN SOL FR RH OUT SOL RR RH IN SOL RR RH OUT SOL RR LH IN SOL RR LH OUT SOL	Solenoid valve operation	Actuator (solenoid) is active ("ACTIVE TEST" with CONSULT-II) or actuator relay is inactive (in fail-safe mode).	ON	<a href="#">BRC-124, "Solenoid and VDC Change-Over Valve System Inspection"</a>
		When actuator (solenoid) is not active and actuator relay is active (ignition switch ON).	OFF	
CV1 CV2 SV1 SV2	VDC switch-over valve status	When actuator (switch-over valve) is active ("ACTIVE TEST" with CONSULT-II) or actuator relay is inactive (when in fail-safe mode).	ON	<a href="#">BRC-124, "Solenoid and VDC Change-Over Valve System Inspection"</a>
		When actuator (switch-over valve) is not active and actuator relay is active (ignition switch ON).	OFF	
DECEL G-SEN	Longitudinal acceleration detected by Decel G-Sensor	Vehicle stopped	ON	<a href="#">BRC-122, "Yaw Rate/Side/Decel G Sensor System Inspection"</a>
		Vehicle running	OFF	
FLUID LEV SW	ON/OFF status of brake fluid level switch	When brake fluid level switch ON	ON	<a href="#">DI-41, "WARNING LAMPS"</a>
		When brake fluid level switch OFF	OFF	
VDC FAIL SIG TCS FAIL SIG ABS FAIL SIG EBD FAIL SIG	Fail signal status	VDC fail TCS fail ABS fail EBD fail	OFF	VDC system TCS system ABS system EBD system

A  
B  
C  
D  
E  
BRC  
G  
H  
I  
J  
K  
L  
M

# TROUBLE DIAGNOSIS

[VDC/TCS/ABS]

---

Note 1: Confirm tire pressure is normal.

Note 2: ON/OFF timing of ABS warning lamp

ON: For approximately 1.8 seconds after ignition switch is turned ON, or when a malfunction is detected.

OFF: Approximately 1.8 seconds after ignition switch is turned ON (when system is in normal operation) and TCS/VDC function is not activated.

Note 3: ON/OFF timing of VDC OFF indicator lamp

ON: For approximately 1.8 seconds after ignition switch is turned ON, or when a malfunction is detected and VDC OFF switch is ON.

OFF: Approximately 1.8 seconds after ignition switch is turned ON (when system is in normal operation.) And when VDC OFF switch is OFF.

Note 4: SLIP indicator lamp ON/OFF timing

ON: For approximately 1.8 seconds after ignition switch is turned ON, or when a malfunction is detected and TCS/VDC function is activated while driving.

OFF: Approximately 1.8 seconds after ignition switch is turned ON (when system is in normal operation) and TCS/VDC function is not activated.

Flashing: TCS/VDC function is active during driving

# TROUBLE DIAGNOSIS

[VDC/TCS/ABS]

## CONSULT-II Function (ABS)

EFS002Y4

CONSULT-II can display each diagnostic item using the diagnostic test modes shown following.

ABS diagnostic mode	Description
WORK SUPPORT	Supports inspection and adjustments. Commands are transmitted to the ABS actuator and electric unit (control unit) for setting the status suitable for required operation, input/output signals are received from the ABS actuator and electric unit (control unit) and received data is displayed.
SELF-DIAG RESULTS	Displays ABS actuator and electric unit (control unit) self-diagnosis results.
DATA MONITOR	Displays ABS actuator and electric unit (control unit) input/output data in real time.
CAN DIAG SUPPORT MNTR	The result of transmit/receive diagnosis of CAN communication can be read.
ACTIVE TEST	Operation of electrical loads can be checked by sending drive signal to them.
FUNCTION TEST	Conducted by CONSULT-II instead of a technician to determine whether each system is "OK" or "NG".
ECU PART NUMBER	ABS actuator and electric unit (control unit) part number can be read.

A  
B  
C  
D  
E

**BRC**

G  
H  
I  
J  
K  
L  
M

## CONSULT-II BASIC OPERATION PROCEDURE

1. Turn ignition switch OFF.
2. Connect CONSULT-II and CONSULT-II CONVERTER to the data link connector.

**CAUTION:**

If CONSULT-II is used with no connection of CONSULT-II CONVERTER, malfunctions might be detected in self-diagnosis depending on control unit which carry out CAN communication.

3. Turn ignition switch ON.

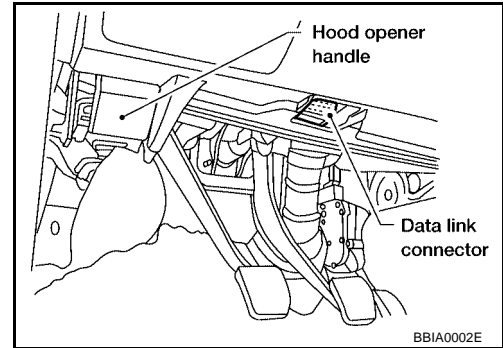

4. Touch "START (NISSAN BASED VHCL)".

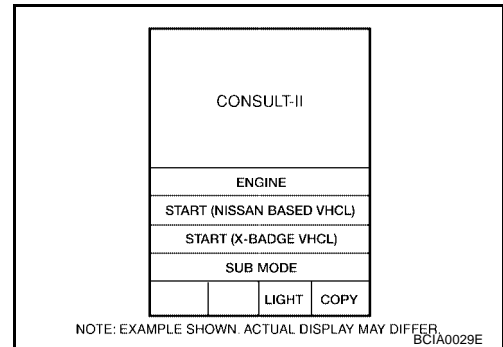

5. Touch "ABS" in the "Select System" screen.  
If "ABS" is not indicated, go to [GI-36, "CONSULT-II Data Link Connector \(DLC\) Circuit"](#).

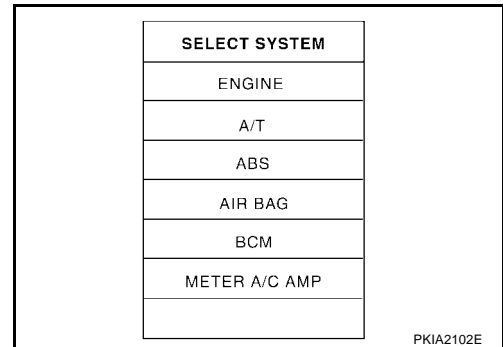

6. Select the required diagnostic location from the "Diagnosis Mode Selection" screen.  
For further information, see the CONSULT-II Operation Manual.

## SELF-DIAGNOSIS

### Description

If an error is detected in the system, the ABS warning lamp will turn on. In this case, perform self-diagnosis as follows:

### Operation Procedure

1. Turn ignition switch OFF.
2. Connect CONSULT-II and CONSULT-II CONVERTER to the data link connector.  
**CAUTION:**  
If CONSULT-II is used with no connection of CONSULT-II CONVERTER, malfunctions might be detected in self-diagnosis depending on control unit which carry out CAN communication.
3. Turn ignition switch ON.
4. Start engine and drive at approximately 30 km/h (19 MPH) for approximately 1 minute.
5. After stopping the vehicle, with the engine running, touch "START (NISSAN BASED VHCL)", "ABS", "SELF-DIAG RESULTS" in order on the CONSULT-II screen.



**CAUTION:**

If “START (NISSAN BASED VHCL)” is touched immediately after starting the engine or turning on the ignition switch, “ABS” might not be displayed in the Select System screen. In this case, repeat the operation from step 1.

6. The self-diagnostic results are displayed. (If necessary, the self-diagnostic results can be printed out by touching “COPY”.)
  - When “NO FAILURE” is displayed, check the ABS warning lamp, SLIP indicator lamp and VDC OFF indicator lamp.
7. Conduct the appropriate inspection from the display item list, and repair or replace the malfunctioning component.
8. Start engine and drive at approximately 30 km/h (19 MPH) for approximately 1 minute.

**CAUTION:**

● When a wheel sensor “short-circuit” is detected, if the vehicle is not driven at 30 km/h (19 MPH) for at least 1 minute, the ABS warning lamp will not turn off even if the malfunction is repaired.

9. Turn ignition switch OFF to prepare for erasing the memory.
10. Start the engine and touch “START (NISSAN BASED VHCL)”, “ABS”, “SELF-DIAG RESULTS”, “ERASE MEMORY” in order on the CONSULT-II screen to erase the error memory.  
If “ABS” is not indicated, go to [GI-36, "CONSULT-II Data Link Connector \(DLC\) Circuit"](#).

**CAUTION:**

If the error memory is not erased, re-conduct the operation from step 5.

11. For the final inspection, drive at approximately 30 km/h (19 MPH) for approximately 1 minute and confirm that the ABS warning lamp, SLIP indicator lamp, and VDC OFF indicator lamp are off.

### Display Item List

Self-diagnostic item	Malfunction detecting condition	Check system
FR LH SENSOR 1 [C1104]	Circuit of front LH wheel sensor is open	
RR RH SENSOR 1 [C1101]	Circuit of rear RH wheel sensor is open	
FR RH SENSOR 1 [C1103]	Circuit of front RH wheel sensor is open	
RR LH SENSOR 1 [C1102]	Circuit of rear LH wheel sensor is open	
FR LH SENSOR 2 [C1108]	Circuit of front LH wheel sensor is shorted, or sensor power voltage is unusual. ABS actuator and electric unit (control unit) cannot identify sensor pulses, because of large gap between wheel sensor and sensor rotor.	
RR RH SENSOR 2 [C1105]	Circuit of rear RH wheel sensor is shorted, or sensor power voltage is unusual. ABS actuator and electric unit (control unit) cannot identify sensor pulses, because of large gap between wheel sensor and sensor rotor.	
FR RH SENSOR 2 [C1107]	Circuit of front RH wheel sensor is shorted, or sensor power voltage is unusual. ABS actuator and electric unit (control unit) cannot identify sensor pulses, because of large gap between wheel sensor and sensor rotor.	
RR LH SENSOR 2 [C1106]	Circuit of rear LH wheel sensor is shorted, or sensor power voltage is unusual. ABS actuator and electric unit (control unit) cannot identify sensor pulses, because of large gap between wheel sensor and sensor rotor.	
STOP LAMP SW 1 [C1116]	Stop lamp switch or circuit malfunction.	
ST ANGLE SEN CIRCUIT [C1143, C1163]	Neutral position of steering angle sensor is dislocated, or steering angle sensor is malfunctioning.	

[BRC-119. "Wheel Sensor System Inspection"](#)  
(Note 1)

[BRC-126. "Stop Lamp Switch System Inspection"](#)

[BRC-121. "Steering Angle Sensor System Inspection"](#)

# TROUBLE DIAGNOSIS

[VDC/TCS/ABS]

Self-diagnostic item	Malfunction detecting condition	Check system	
YAW RATE SENSOR [C1145]	Yaw rate sensor has generated an error, or yaw rate sensor signal line is open or shorted.	<a href="#">BRC-122, "Yaw Rate/Side/Decel G Sensor System Inspection"</a>	
FR LH IN ABS SOL [C1120]	Circuit of front LH IN ABS solenoid is open or shorted, or control line is open or shorted to power supply or ground.		
FR LH OUT ABS SOL [C1121]	Circuit of front LH OUT ABS solenoid is open or shorted, or control line is open or shorted to power supply or ground.		
RR RH IN ABS SOL [C1126]	Circuit of rear RH IN ABS solenoid is open or shorted, or control line is open or shorted to power supply or ground.		
RR RH OUT ABS SOL [C1127]	Circuit of rear RH OUT ABS solenoid is open or shorted, or control line is open or shorted to power supply or ground.		
FR RH IN ABS SOL [C1122]	Circuit of front RH IN ABS solenoid is open or shorted, or control line is open or shorted to power supply or ground.		
FR RH OUT ABS SOL [C1123]	Circuit of front RH OUT ABS solenoid is open or shorted, or control line is open or shorted to power supply or ground.		
RR LH IN ABS SOL [C1124]	Circuit of rear LH IN ABS solenoid is open or shorted, or control line is open or shorted to power supply or ground.		<a href="#">BRC-124, "Solenoid and VDC Change-Over Valve System Inspection"</a>
RR LH OUT ABS SOL [C1125]	Circuit of rear LH OUT ABS solenoid is open or shorted, or control line is open or shorted to power supply or ground.		
CV1 [C1164]	Front side VDC switch-over solenoid valve (cut valve) is open or shorted, or control line is open or shorted to power supply or ground.		
CV2 [C1165]	Rear side VDC switch-over solenoid valve (cut valve) is open or shorted, or control line is open or shorted to power supply or ground.		
SV1 [C1166]	Front side VDC switch-over solenoid valve (suction valve) is open or shorted, or control line is open or shorted to power supply or ground.		
SV2 [C1167]	Rear side VDC switch-over solenoid valve (suction valve) is open or shorted, or control line is open or shorted to power supply or ground.		
PUMP MOTOR (Note 3) [C1111]	During actuator motor operation with ON, when actuator motor turns OFF or when control line for actuator motor relay is open. During actuator motor operation with OFF, when actuator motor turns ON or when control line for relay is shorted to ground.	<a href="#">BRC-125, "Actuator Motor, Motor Relay, and Circuit Inspection"</a>	
BATTERY VOLTAGE [ABNORMAL] [C1109]	ABS actuator and electric unit (control unit) power voltage is too low.	<a href="#">BRC-127, "ABS/TCS/VDC Control Unit Power and Ground Systems Inspection"</a>	
ST ANGLE SEN SIGNAL [C1144]	Neutral position correction of steering angle sensor is not finished.	<a href="#">BRC-121, "Steering Angle Sensor System Inspection"</a>	
ST ANG SEN COM CIR [C1156]	CAN communication line or steering angle sensor has generated an error.		
LONGITUDINAL G-SENSOR [C1113]	Longitudinal G-sensor is malfunctioning, or signal line of longitudinal G-sensor is open or shorted.	<a href="#">BRC-122, "Yaw Rate/Side/Decel G Sensor System Inspection"</a>	
CONTROLLER FAILURE [C1110]	Internal malfunction of ABS actuator and electric unit (control unit)	<a href="#">BRC-121, "ABS/TCS/VDC Control Unit Inspection"</a>	
CAN COMM CIRCUIT [U1000]	<ul style="list-style-type: none"> <li>● CAN communication line is open or shorted.</li> <li>● ABS actuator and electric unit (control unit) internal malfunction</li> <li>● Battery voltage for ECM is suddenly interrupted for approximately 0.5 seconds or more.</li> </ul>	<a href="#">BRC-128, "CAN Communication System Inspection"</a> (Note 2)	

# TROUBLE DIAGNOSIS

[VDC/TCS/ABS]

Self-diagnostic item	Malfunction detecting condition	Check system
LATERAL G-SENSOR [C1146]	Lateral G-sensor is malfunctioning, or signal line of lateral G-sensor is open or shorted.	<a href="#">BRC-122, "Yaw Rate/Side/Decel G Sensor System Inspection"</a>
BR FLUID LEVEL LOW [C1155]	Brake fluid level drops or circuit between ABS actuator and electric unit (control unit) and brake fluid level switch is open or shorted.	<a href="#">DI-41, "WARNING LAMPS"</a>
ENGINE SPEED SIG	Engine speed signal from ECM is abnormal.	<a href="#">BRC-120, "Engine System Inspection"</a>
ENGINE SIGNAL 1 [C1130]	ECM judges the communication between ABS/TCS/VDC control unit and ECM is abnormal.	<a href="#">BRC-128, "CAN Communication System Inspection"</a>
STOP LAMP SW 2 [C1176]	ASCD brake switch or circuit malfunction.	<a href="#">EC-702, "AUTOMATIC SPEED CONTROL DEVICE (ASCD)"</a>

Note 1. If wheel sensor 2 for each wheel is indicated, check ABS actuator and electric unit (control unit) power supply voltage in addition to wheel sensor circuit check.

Note 2. If multiple malfunctions are detected including CAN communication line [U1000], perform diagnosis for CAN communication line first.

Note 3: "ACTUATOR RLY" on the CONSULT-II self-diagnosis results indicates the malfunction of the actuator motor relay or circuit.

## DATA MONITOR

### Operation Procedure

- After turning OFF the ignition switch, connect CONSULT-II and the CONVERTER to the data link connector.

**CAUTION:**

If CONSULT-II is used with no connection of CONSULT-II CONVERTER, malfunctions might be detected in self-diagnosis depending on control unit which carry out CAN communication.

- Touch "START (NISSAN BASED VHCL)", "ABS", "DATA MONITOR" in order on the CONSULT-II screen. If "ABS" is not indicated, go to [GI-36, "CONSULT-II Data Link Connector \(DLC\) Circuit"](#).

**CAUTION:**

When "START (NISSAN BASED VHCL)" is touched immediately after starting the engine or turning on the ignition switch, "ABS" might not be displayed in the system selection screen. In this case, repeat the operation from step 2.

- Return to the Monitor Item Selection screen, and touch "C/U INPUT ITEM", "MAIN ITEM" or "ITEM MENU SELECTION". Refer to the following information.
- When "START" is touched, the data monitor screen is displayed.

### Display Item List

Item (Unit)	Data monitor item selection			Remarks
	ECU INPUT SIGNALS	MAIN SIGNALS	SELECTION FROM MENU	
GEAR	×	×	×	Gear position judged by PNP switch signal is displayed.
FR RH SENSOR (km/h, MPH)	×	×	×	Wheel speed calculated by front RH wheel sensor signal is displayed.
FR LH SENSOR (km/h, MPH)	×	×	×	Wheel speed calculated by front LH wheel sensor signal is displayed.
RR RH SENSOR (km/h, MPH)	×	×	×	Wheel speed calculated by rear RH wheel sensor signal is displayed.
RR LH SENSOR (km/h, MPH)	×	×	×	Wheel speed calculated by rear LH wheel sensor signal is displayed.

# TROUBLE DIAGNOSIS

[VDC/TCS/ABS]

Item (Unit)	Data monitor item selection			Remarks
	ECU INPUT SIGNALS	MAIN SIGNALS	SELECTION FROM MENU	
BATTERY VOLT (V)	×	×	×	Voltage supplied to ABS actuator and electric unit (control unit) is displayed.
SLCT LVR POSI	×	×	×	Shift position judged by PNP switch signal.
ACCEL POS SIG (%)	×	-	×	Throttle valve open/close status judged by LAN communication signal is displayed.
ENGINE SPEED (rpm)	×	×	×	Engine speed judged by LAN communication signal is displayed.
STR ANGLE SIG (deg)	×	-	×	Steering angle detected by steering angle sensor is displayed.
YAW RATE SEN (d/s)	×	×	×	Yaw rate detected by yaw rate sensor is displayed.
DECEL G SEN (d/s)	×	×	×	Longitudinal acceleration detected by Decel G-sensor is displayed.
SIDE G-SENSOR (m/s <sup>2</sup> )	×	-	×	Transverse acceleration detected by side G-sensor is displayed.
STOP LAMP SW (ON/OFF)	×	×	×	Stop lamp switch (ON/OFF) status is displayed.
OFF SW (ON/OFF)	×	×	×	VDC OFF switch (ON/OFF) status is displayed.
ABS WARN LAMP (ON/OFF)	-	×	×	ABS warning lamp (ON/OFF) status is displayed.
SLIP LAMP (ON/OFF)	-	×	×	SLIP indicator lamp (ON/OFF) status is displayed.
FR LH IN SOL (ON/OFF)	-	×	×	Front LH IN ABS solenoid (ON/OFF) status is displayed.
FR LH OUT SOL (ON/OFF)	-	×	×	Front LH OUT ABS solenoid (ON/OFF) status is displayed.
RR RH IN SOL (ON/OFF)	-	×	×	Rear RH IN ABS solenoid (ON/OFF) status is displayed.
RR RH OUT SOL (ON/OFF)	-	×	×	Rear RH OUT ABS solenoid (ON/OFF) status is displayed.
FR RH IN SOL (ON/OFF)	-	×	×	Front RH IN ABS solenoid (ON/OFF) status is displayed.
FR RH OUT SOL (ON/OFF)	-	×	×	Front RH OUT ABS solenoid (ON/OFF) status is displayed.
RR LH IN SOL (ON/OFF)	-	×	×	Rear LH IN ABS solenoid (ON/OFF) status is displayed.
RR LH OUT SOL (ON/OFF)	-	×	×	Rear LH OUT ABS solenoid (ON/OFF) status is displayed.
OFF LAMP (ON/OFF)	-	×	×	OFF Lamp (ON/OFF) status is displayed.
MOTOR RELAY (ON/OFF)	-	×	×	ABS motor relay signal (ON/OFF) status is displayed.
ACTUATOR RLY (ON/OFF)	-	×	×	ABS actuator relay signal (ON/OFF) status is displayed.
CV1 (ON/OFF)	-	-	×	Front side switch-over solenoid valve (cut valve) (ON/OFF) status is displayed.

# TROUBLE DIAGNOSIS

[VDC/TCS/ABS]

Item (Unit)	Data monitor item selection			Remarks
	ECU INPUT SIGNALS	MAIN SIGNALS	SELECTION FROM MENU	
CV2 (ON/OFF)	-	-	×	Rear side switch-over solenoid valve (cut-valve) (ON/OFF) status is displayed.
SV1 (ON/OFF)	-	-	×	Front side switch-over solenoid valve (suction valve) (ON/OFF) status is displayed.
SV2 (ON/OFF)	-	-	×	Rear side switch-over solenoid valve (suction valve) (ON/OFF) status is displayed.
VDC FAIL SIG (ON/OFF)	-	-	×	VDC fail signal (ON/OFF) status is displayed.
TCS FAIL SIG (ON/OFF)	-	-	×	TCS fail signal (ON/OFF) status is displayed.
ABS FAIL SIG (ON/OFF)	-	-	×	ABS fail signal (ON/OFF) status is displayed.
EBD FAIL SIG (ON/OFF)	-	-	×	EBD fail signal (ON/OFF) status is displayed.
FLUID LEV SW (ON/OFF)	×	-	×	Brake fluid level switch (ON/OFF) status is displayed.
EBD SIGNAL (ON/OFF)	-	-	×	EBD operation (ON/OFF) status is displayed.
ABS SIGNAL (ON/OFF)	-	-	×	ABS operation (ON/OFF) status is displayed.
TCS SIGNAL (ON/OFF)	-	-	×	TCS operation (ON/OFF) status is displayed.
VDC SIGNAL (ON/OFF)	-	-	×	VDC operation (ON/OFF) status is displayed.
TRQ MAP S/C	-	-	×	S/C is selected for engine torque map
TRQ MAP N/A	-	-	×	N/A is selected for engine

×: Applicable  
-: Not applicable

## ACTIVE TEST

### CAUTION:

- Do not perform active test while driving.
- Make sure to completely bleed air from the brake system.
- The ABS and brake (EBD) warning lamps turn on during the active test.

## Operation Procedure

1. Connect the CONSULT-II and CONVERTER to the data link connector and start the engine.

### CAUTION:

If CONSULT-II is used with no connection of CONSULT-II CONVERTER, malfunctions might be detected in self-diagnosis depending on control unit which carry out CAN communication.

2. Touch "START (NISSAN BASED VHCL)" on the display screen.
3. Touch "ABS".  
If "ABS" is not indicated, go to [GI-36, "CONSULT-II Data Link Connector \(DLC\) Circuit"](#).
4. Touch "ACTIVE TEST".

# TROUBLE DIAGNOSIS

[VDC/TCS/ABS]

5. The test item selection screen is displayed.
6. Touch necessary test item.

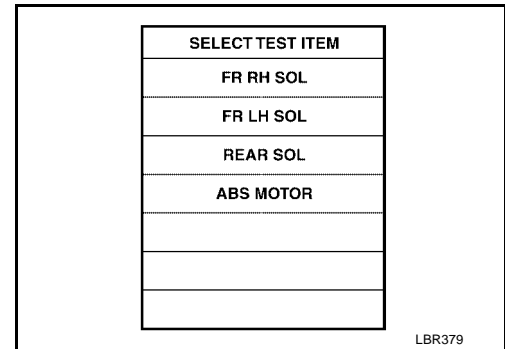

7. With the "MAIN ITEM" display shown in reverse, touch "START".
8. The Active Test screen will be displayed, so conduct the following test.

## Solenoid Valve Operation Chart

Operation		ABS solenoid valve			ABS solenoid valve (ACT)		
		UP	KEEP	DOWN	UP	ACTUA-TOR UP	ACTUA-TOR KEEP
FR RH SOL FR RH ABS SOLE- NOID (ACT)	FR RH IN SOL	OFF	ON	ON	OFF	OFF	OFF
	FR RH OUT SOL	OFF	OFF	ON*	OFF	OFF	OFF
FR LH SOL FR LH ABS SOLE- NOID (ACT)	FR LH IN SOL	OFF	ON	ON	OFF	OFF	OFF
	FR LH OUT SOL	OFF	OFF	ON*	OFF	OFF	OFF
RR RH SOL RR RH ABS SOLE- NOID (ACT)	RR RH IN SOL	OFF	ON	ON	OFF	OFF	OFF
	RR RH OUT SOL	OFF	OFF	ON*	OFF	OFF	OFF
RR LH SOL RR LH ABS SOLE- NOID (ACT)	RR LH IN SOL	OFF	ON	ON	OFF	OFF	OFF
	RR LH OUT SOL	OFF	OFF	ON*	OFF	OFF	OFF
REAR SOL	RR RH IN SOL	OFF	ON	ON	OFF	OFF	OFF
	RR RH OUT SOL	OFF	OFF	ON*	OFF	OFF	OFF
	RR LH IN SOL	OFF	ON	ON	OFF	OFF	OFF
	RR LH OUT SOL	OFF	OFF	ON*	OFF	OFF	OFF

\*: ON for 1 to 2 seconds after the touch, and then OFF

### NOTE:

- If active test is performed with brake pedal depressed, pedal stroke may change. This is normal.
- "TEST IS STOPPED" is displayed approximately 10 seconds after operation starts.
- After "TEST IS STOPPED" is displayed, to perform test again, repeat Step 6.

### ABS Motor

Touch "ON" and "OFF" on the screen. Check that ABS motor relay operates as shown in table below.

Operation	ON	OFF
ABS actuator relay	ON	ON
ABS motor relay	ON	OFF

### NOTE:

- If active test is performed with brake pedal depressed, pedal stroke may change. This is normal.
- "TEST IS STOPPED" is displayed approximately 10 seconds after operation starts.

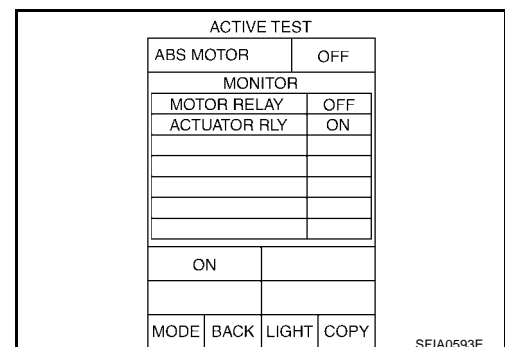

**TROUBLE DIAGNOSIS FOR SELF-DIAGNOSTIC ITEMS**

PFP:00000

**Wheel Sensor System Inspection**

EFS002XB

## INSPECTION PROCEDURE

**1. CONNECTOR INSPECTION**

Disconnect the ABS actuator and electric unit connector E125 and wheel sensor of malfunctioning code. Check the terminals for deformation, disconnection, looseness or damage.

OK or NG

OK &gt;&gt; GO TO 2.

NG &gt;&gt; Repair or replace as necessary.

**2. CHECK WHEEL SENSOR OUTPUT SIGNAL**

1. Disconnect connectors from wheel sensor of malfunction code No.
2. Connect ABS active wheel sensor tester (J-45741) to wheel sensor using appropriate adapter.
3. Turn on the ABS active wheel sensor tester power switch.

**NOTE:**

The green POWER indicator should illuminate. If the POWER indicator does not illuminate, replace the battery in the ABS active wheel sensor tester before proceeding.

4. Spin the wheel of the vehicle by hand and observe the red SENSOR indicator on the ABS active wheel sensor tester. The red SENSOR indicator should flash on and off to indicate an output signal.

**NOTE:**

If the red SENSOR indicator illuminates but does not flash, reverse the polarity of the tester leads and retest.

Does the ABS active wheel sensor tester detect a signal?

Yes &gt;&gt; GO TO 3.

No &gt;&gt; GO TO 6.

**3. CHECK TIRES**

Check for inflation pressure, wear and size of each tire.

Are tire pressure and size correct and is tire wear within specifications?

Yes &gt;&gt; GO TO 4.

No &gt;&gt; Adjust tire pressure or replace tire(s).

**4. CHECK WHEEL BEARINGS**

Check wheel bearing axial end play. Refer to [FAX-5, "FRONT WHEEL BEARING"](#) or [RAX-5, "REAR WHEEL BEARING"](#).

OK or NG

OK &gt;&gt; GO TO 5.

NG >> Repair as necessary. Refer to [FAX-5, "FRONT WHEEL BEARING"](#) or [RAX-5, "REAR WHEEL BEARING"](#).

**5. CHECK SENSOR ROTORS**

Check sensor rotors for teeth damage.

OK or NG

OK &gt;&gt; GO TO 6.

NG >> Replace sensor rotor. Refer to [BRC-137, "Removal and Installation"](#).

# TROUBLE DIAGNOSIS FOR SELF-DIAGNOSTIC ITEMS

[VDC/TCS/ABS]

## 6. CHECK WIRING HARNESS FOR SHORT CIRCUIT

1. Disconnect ABS actuator and electric unit (control unit) connector and wheel sensor connector of malfunction code No.
2. Check resistance between harness connector terminal and ground.

**Continuity should not exist.**

OK or NG

- OK >> GO TO 7.  
NG >> Repair the circuit.

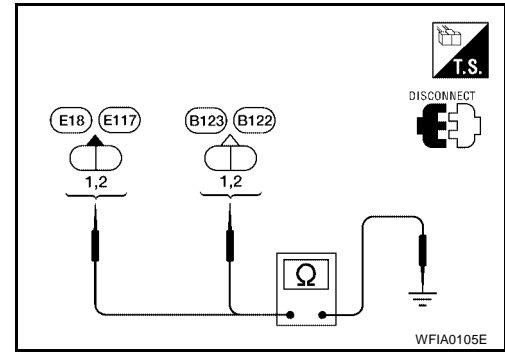

## 7. CHECK WIRING HARNESS FOR OPEN CIRCUIT

1. Disconnect ABS actuator and electric unit (control unit) connector and wheel sensor connector of malfunction code No.
2. Check continuity between both wiring harness ends.

Sensor	ABS actuator and electric unit (control unit)		Wheel sensor		Continuity
	Connector - terminal	Wire color	Connector - terminal	Wire color	
Front LH	E125 - 14	G	E18 - 1	G	Yes
	E125 - 13	R	E18 - 2	R	
Front RH	E125 - 26	B	E117 - 1	B	
	E125 - 27	W	E117 - 2	W	
Rear LH	E125 - 29	P	B123 - 1	P	
	E125 - 28	L	B123 - 2	L	
Rear RH	E125 - 11	V	B122 - 1	V	
	E125 - 12	LG	B122 - 2	LG	

**Continuity should exist.**

OK or NG

- OK >> Replace the ABS actuator and electric unit (control unit). Refer to [BRC-85, "Removal and Installation"](#).
- NG >> Repair the circuit.

## Engine System Inspection

EFS002XC

### INSPECTION PROCEDURE

#### 1. SELF-DIAGNOSIS RESULT CHECK

Check self-diagnosis results.

Self-diagnosis results
ENGINE SIGNAL 1

Is the above displayed in the self-diagnosis display items?

- Yes >> GO TO 2.  
No >> **INSPECTION END.**



## 2. ENGINE SYSTEM INSPECTION

1. Perform ECM self-diagnosis and repair as necessary.
2. Perform ABS actuator and electric unit (control unit) self-diagnosis again.

OK or NG

- OK >> **INSPECTION END.**  
 NG >> Repair as necessary.

### ABS/TCS/VDC Control Unit Inspection

EFS002XD

INSPECTION PROCEDURE

#### 1. SELF-DIAGNOSIS RESULT CHECK

Check self-diagnosis results.

Self-diagnosis results
CONTROLLER FAILURE

Is the above displayed in the self-diagnosis display items?

- Yes >> Replace ABS actuator and electric unit. Refer to [BRC-85, "Removal and Installation"](#) .  
 No >> **INSPECTION END.**

### Steering Angle Sensor System Inspection

EFS002XF

INSPECTION PROCEDURE

#### 1. SELF-DIAGNOSIS RESULT CHECK

Check self-diagnosis results.

Self-diagnosis results
ST ANGLE SEN CIRCUIT
ST ANGLE SEN SIGNAL

Is the above displayed in the self-diagnosis item?

- Yes >> GO TO 3.  
 No >> GO TO 2.

## 2. DATA MONITOR CHECK

Conduct "Data Monitor" of the "STEERING ANGLE SIGNAL" to check if the status is normal.

Steering condition	Data monitor
Straight-ahead	-5deg - +5deg
Turn wheel 90° to the right.	Approx. +90°
Turn wheel 90° to the left.	Approx. -90°

OK or NG

- OK >> **INSPECTION END.**  
 NG >> GO TO 3.

## 3. CONNECTOR INSPECTION

1. Disconnect the ABS actuator and electric unit connector E125 and steering angle sensor M47.
2. Check the terminals for deformation, disconnection, looseness or damage.

OK or NG

- OK >> GO TO 4.  
 NG >> Repair or replace as necessary.

4. CHECKING STEERING ANGLE SENSOR POWER AND GROUND

1. Turn the ignition switch on.
2. Check voltage between steering angle sensor connector M47 and ground.

Steering angle sensor connector E125	Body ground	Measured value (Approx.)
1 (Y/R)	—	12V
3 (G)		

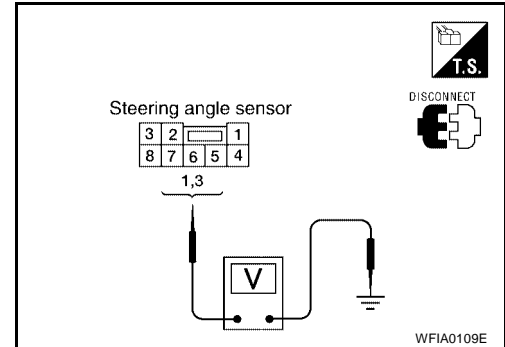

3. Check resistance between steering angle sensor connector M47 and ground.

Steering angle sensor connector E125	Body ground	Measured value (Approx.)
2 (B)	—	0 Ω

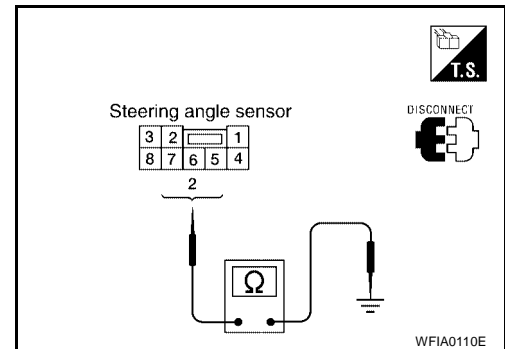

OK or NG

OK >> Check the CAN communication system. Refer to [BRC-128, "CAN Communication System Inspection"](#) . If the CAN communication system is OK, replace spiral cable (steering angle sensor) and adjust neutral position of steering angle sensor. Refer to [BRC-135, "Adjustment of Steering Angle Sensor Neutral Position"](#) .

NG >> Repair the circuit.

Yaw Rate/Side/Decel G Sensor System Inspection

EFS002XG

**CAUTION:**

Sudden turns (such as spin turns, acceleration turns), drifting, etc. When VDC function is OFF (VDC SW ON) may cause the yaw rate/side/deccl G sensor system to indicate a problem. However this is not a problem if normal operation can be resumed after restarting the engine.

INSPECTION PROCEDURE

1. SELF-DIAGNOSIS RESULT CHECK

Check self-diagnosis results.

Self-diagnosis results
YAW RATE SENSOR
SIDE G-SEN CIRCUIT

**CAUTION:**

When on a turntable, such as at a parking structure entrance, or when on a moving object with the engine running, the VDC OFF indicator lamp might turn on and the self-diagnosis using the CONSULT-II the yaw rate sensor system might be displayed, but in this case there is no problem with the yaw rate sensor system. As soon as the vehicle leaves the turntable or moving object, restart the engine to return the system to normal.

Is the above displayed in the self-diagnosis display items?

Yes >> GO TO 2.

No >> INSPECTION END.

# TROUBLE DIAGNOSIS FOR SELF-DIAGNOSTIC ITEMS

[VDC/TCS/ABS]

## 2. CONNECTOR INSPECTION

Disconnect the ABS actuator and electric unit connector E125 and yaw rate/side/decel G sensor connector M46.

Check the terminals for deformation, disconnection, looseness or damage.

OK or NG

OK >> GO TO 3.

NG >> Repair or replace as necessary.

## 3. YAW RATE SENSOR/SIDE/DECEL G SENSOR HARNESS INSPECTION

1. Turn off the ignition switch and disconnect yaw rate sensor/side/decel G sensor connector M46 and ABS actuator and electric unit connector E125.

2. Check the continuity between the ABS actuator and electric unit vehicle side connector and the yaw rate/side/decel G sensor connector M46.

ABS actuator and electric unit (control unit) connector E125	Yaw rate/side/decel G sensor connector M46	Continuity
19 (O)	1 (O)	Continuity should exist.
36 (Y)	2 (Y)	
35 (G)	3 (G)	
34 (B)	4 (B)	
4 (R)	5 (R)	
6 (W)	6 (W)	

OK or NG

OK >> GO TO 4.

NG >> Repair or replace as necessary.

## 4. YAW RATE SENSOR/SIDE/DECEL G SENSOR INSPECTION

1. Connect the yaw rate sensor/side/decel G sensor M46 and ABS actuator and electric unit connector E125.

2. Use "Data Monitor" to check if the yaw rate sensor/side/decel G sensor are normal.

Vehicle status	Yaw rate sensor (Data monitor standard)	Side G sensor (Data monitor standard)
When stopped	-4 to +4 deg/s	-1.1 to +1.1 m/s <sup>2</sup>
Right hand turn	Negative value	Negative value
Left turn	Positive value	Positive value

OK or NG

OK >> **INSPECTION END.**

NG >> Replace the yaw rate sensor/side/decel G sensor. Refer to [BRC-141, "Removal and Installation"](#) .

**Solenoid and VDC Change-Over Valve System Inspection**

## INSPECTION PROCEDURE

**1. SELF-DIAGNOSIS RESULT CHECK**

Check self-diagnosis results.

Self-diagnosis results
FR LH IN ABS SOL
FR LH OUT ABS SOL
RR RH IN ABS SOL
RR RH OUT ABS SOL
FR RH IN ABS SOL
FR RH OUT ABS SOL
RR LH IN ABS SOL
RR LH OUT ABS SOL
CV 1
CV 2
SV 1
SV 2

Is the above displayed in the self-diagnosis display items?

Yes >> GO TO 2.

No >> **INSPECTION END.**

**2. CONNECTOR INSPECTION**

1. Disconnect ABS actuator and electric unit (control unit) connector E125.
2. Check the terminals for deformation, disconnection, looseness or damage.

OK or NG

OK >> GO TO 3.

NG >> Repair or replace as necessary.

# TROUBLE DIAGNOSIS FOR SELF-DIAGNOSTIC ITEMS

[VDC/TCS/ABS]

## 3. CHECKING SOLENOID POWER AND GROUND

1. Disconnect ABS actuator and electric unit (control unit) connector E125.
2. Check voltage between ABS actuator and electric unit (control unit) connector E125 and ground.

ABS actuator and electric unit (control unit) connector E125	Body ground	Measured value (Approx.)
16 (G/R)	—	12V

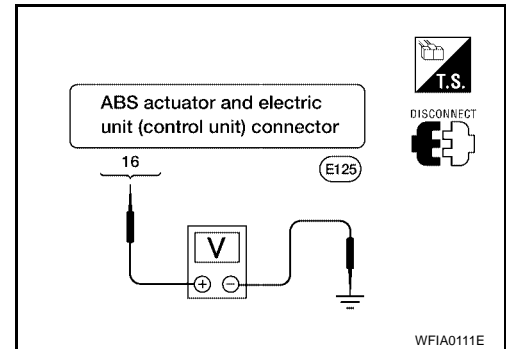

3. Check resistance between ABS actuator and electric unit (control unit) connector E125 and body ground.

ABS actuator and electric unit (control unit) connector E125	Body ground	Measured value $\Omega$ (Approx.)
31 (B)	—	0 $\Omega$
46 (B)		

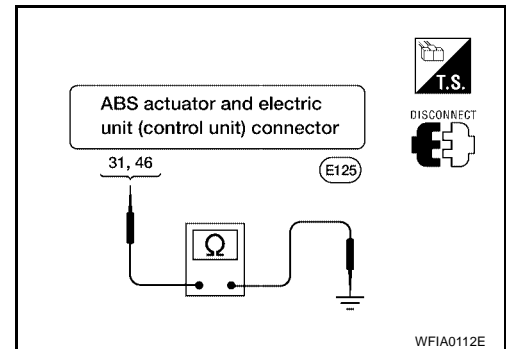

OK or NG

- OK >> Perform self-diagnosis again. If the same results appear, replace ABS actuator and electric unit (control unit). Refer to [BRC-121, "ABS/TCS/VDC Control Unit Inspection"](#).
- NG >> Repair the circuit.

## Actuator Motor, Motor Relay, and Circuit Inspection

EFS002XI

### INSPECTION PROCEDURE

#### 1. CHECKING SELF-DIAGNOSIS RESULTS

Check self-diagnosis results.

Self-diagnosis results
CONSULT-II display items
PUMP MOTOR

Does "PUMP MOTOR" appear in self-diagnosis results display?

- Yes >> GO TO 2.  
 No >> **INSPECTION END.**

#### 2. CONNECTOR INSPECTION

Disconnect the ABS actuator and electric unit connector E125.  
 Check the terminals for deformation, disconnection, looseness or damage.

OK or NG

- OK >> GO TO 3.  
 NG >> Repair or replace as necessary.

# TROUBLE DIAGNOSIS FOR SELF-DIAGNOSTIC ITEMS

[VDC/TCS/ABS]

## 3. CHECKING ABS MOTOR AND MOTOR RELAY POWER SYSTEM

1. Disconnect ABS actuator and electric unit (control unit) connector.
2. Check voltage between ABS actuator and electric unit (control unit) connector E125 and body ground.

ABS actuator and electric unit (control unit) connector E125	Body ground	Measured value (Approx.)
1 (R/B)	—	12V

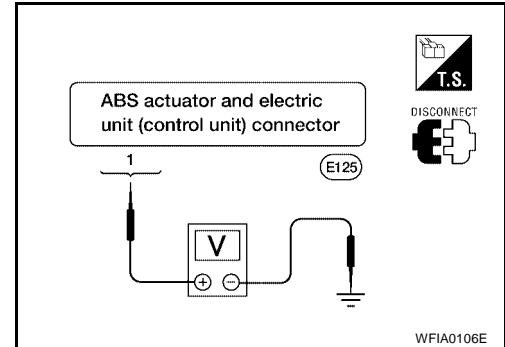

3. Check resistance between ABS actuator and electric unit (control unit) connector E125 and ground.

ABS actuator and electric unit (control unit) connector E125	Body ground	Measured value (Approx.)
46 (B)	—	0Ω

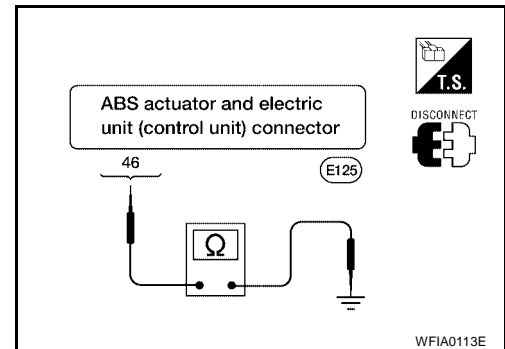

OK or NG

- OK >> Perform self-diagnosis again. If the same result appears, replace ABS actuator and electric unit (control unit). Refer to [BRC-85, "Removal and Installation"](#).
- NG >> Repair the circuit.

## Stop Lamp Switch System Inspection

EFS002XK

### INSPECTION PROCEDURE

#### 1. SELF-DIAGNOSIS RESULT CHECK

Check self-diagnosis results.

Self-diagnosis results
STOP LAMP SW

Is the above displayed in the self-diagnosis display items?

- Yes >> GO TO 2.  
 No >> **INSPECTION END.**

#### 2. CONNECTOR INSPECTION

1. Turn the ignition switch off and disconnect the ABS actuator and electric unit connector E125 and stop lamp switch connector E38.
2. Check the terminals for deformation, disconnection, looseness or damage.

OK or NG

- OK >> GO TO 3.  
 NG >> Repair or replace as necessary.

### 3. STOP LAMP SWITCH INSPECTION

Check the voltage between the ABS actuator and electric unit connector E125 terminal 23 (R/G) and ground.

**23 (R/G) - Ground**

**Brake pedal depressed : Battery voltage (approx. 12V)**

**Brake pedal not depressed : Approx. 0V**

OK or NG

OK >> Connect the connectors and conduct ABS actuator and electric unit self-diagnosis.

NG >> Repair the circuit.

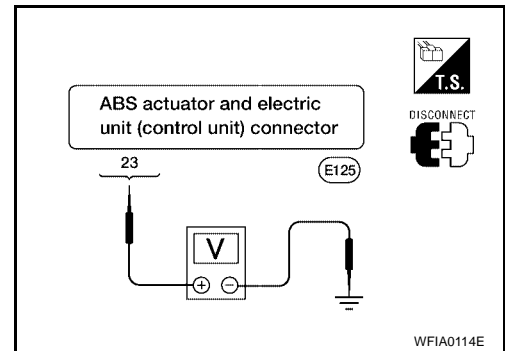

### ABS/TCS/VDC Control Unit Power and Ground Systems Inspection

EFS002XL

INSPECTION PROCEDURE

#### 1. SELF-DIAGNOSIS RESULT CHECK

Check self-diagnosis results.

Self-diagnosis results
BATTERY VOLTAGE

Is the above displayed in the self-diagnosis item?

Yes >> GO TO 2.

No >> **INSPECTION END.**

#### 2. CONNECTOR INSPECTION

1. Turn the ignition switch off and disconnect the ABS actuator and electric unit connector E125.
2. Check the terminals for deformation, disconnection, looseness or damage.

OK or NG

OK >> GO TO 3.

NG >> Repair or replace as necessary.

#### 3. ABS/TCS/VDC CONTROL UNIT POWER AND GROUND CIRCUIT INSPECTION

Measure the voltage and continuity between the ABS actuator and electric unit connector E125 and the ground.

Signal name	ABS actuator and electric unit (control unit) connector E125	Ground	Measured value
Power supply	45 (GR)	—	Battery voltage (Approx. 12V)
Ground	31 (B)		Continuity should exist.
	46 (B)		

OK or NG

OK >> Check the battery for loose terminals, low voltage, etc. Repair as necessary.

NG >> Repair the circuit.

**Brake Fluid Level Sensor System Inspection**

## INSPECTION PROCEDURE

**1. SELF-DIAGNOSIS RESULT CHECK**

1. Check the brake reservoir tank fluid level. If the level is low, add brake fluid.
2. Erase the self-diagnosis results and check the self-diagnosis results.

---

 Self-diagnosis results
 

---



---

 BR FLUID LEVEL LOW
 

---

Is the above displayed in the self-diagnosis display items?

- Yes >> GO TO 2.  
 No >> **INSPECTION END.**

**2. CONNECTOR INSPECTION**

1. Turn the ignition switch off and disconnect the ABS actuator and electric unit connector E125 and brake fluid level sensor connector E21.
2. Check the terminals for deformation, disconnection, looseness or damage.

OK or NG

- OK >> GO TO 3.  
 NG >> Repair or replace as necessary.

**3. CHECK THE HARNESS BETWEEN THE BRAKE FLUID LEVEL SENSOR AND THE ABS ACTUATOR AND ELECTRIC UNIT (CONTROL UNIT)**

Check the continuity between the brake fluid level sensor connector E21 and the ABS actuator and electric unit (control unit) connector E125.

ABS actuator and electric unit connector E125	Brake fluid level sensor connector E21	Continuity
38 (SB)	+ (SB)	Continuity should exist.
38 (SB)	Ground	Continuity should not exist.
Ground	- (B)	Continuity should exist.

OK or NG

- OK >> Connect the connectors and conduct a ABS actuator and electric unit self-diagnosis.  
 NG >> Repair the circuit.

**CAN Communication System Inspection**

## INSPECTION PROCEDURE

**1. CHECK CONNECTOR**

1. Turn ignition switch OFF, disconnect the ABS actuator and electric unit (control unit) connector, and check the terminal for deformation, disconnection, looseness, and so on. If there is a malfunction, repair or replace the terminal.
2. Reconnect connector to perform self-diagnosis.

Is "CAN COMM CIRCUIT" displayed in the self-diagnosis display items?

- Yes >> Print out the self-diagnosis results, and refer to [LAN-8, "CAN COMMUNICATION"](#).  
 No >> Connector terminal connection is loose, damaged, open, or shorted.



# TROUBLE DIAGNOSIS FOR SELF-DIAGNOSTIC ITEMS

[VDC/TCS/ABS]

## Component Inspection

### VDC OFF SWITCH

EFS002X0

- Check the continuity between terminals 1 and 2.
  - 1 -2 : Continuity should exist when pushing the switch.
  - Continuity should not exist when releasing the switch.

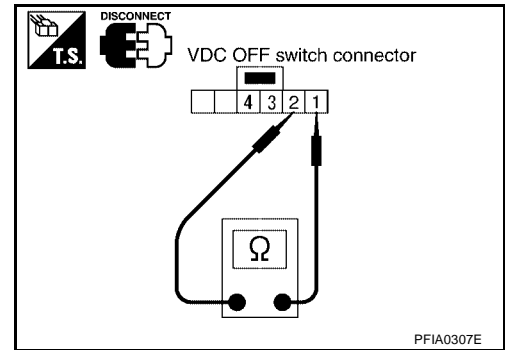

PFI A0307E

A

B

C

D

E

BRC

G

H

I

J

K

L

M

---

**TROUBLE DIAGNOSES FOR SYMPTOMS****ABS Works Frequently****1. CHECK WARNING LAMP ACTIVATION**

---

Make sure warning lamp remains off while driving.

OK or NG

OK >> GO TO 2.

NG >> Carry out self-diagnosis. Refer to [BRC-112, "SELF-DIAGNOSIS"](#) .

**2. CHECK WHEEL SENSORS**

---

Check the following.

- Wheel sensor mounting for looseness
- Wheel sensors for physical damage
- Wheel sensor connectors for terminal damage or loose connections

OK or NG

OK >> GO TO 3.

NG >> Repair as necessary.

**3. CHECK FRONT AXLE**

---

Check front and rear axles for excessive looseness. Refer to [FAX-5, "FRONT WHEEL BEARING"](#) or [RAX-5, "REAR WHEEL BEARING"](#) .

OK or NG

OK >> GO TO 4.

NG >> Repair as necessary.

**4. CHECK BRAKE FLUID PRESSURE**

---

Check brake fluid pressure distribution.

Refer to [BR-36, "Inspection"](#) .

Is brake fluid pressure distribution normal?

Yes >> **INSPECTION END.**

No >> Perform Basic Inspection. Refer to [BRC-107, "Basic Inspection"](#) .

**Unexpected Pedal Action****1. CHECK WARNING LAMP ACTIVATION**

Make sure warning lamp remains off while driving.

OK or NG

OK >> GO TO 2.

NG >> Carry out self-diagnosis. Refer to [BRC-112, "SELF-DIAGNOSIS"](#) .

**2. CHECK BRAKE PEDAL STROKE**

Check brake pedal stroke.

Is pedal stroke excessive?

Yes >> Perform Basic Inspection. Refer to [BRC-107, "Basic Inspection"](#) .

No >> GO TO 3.

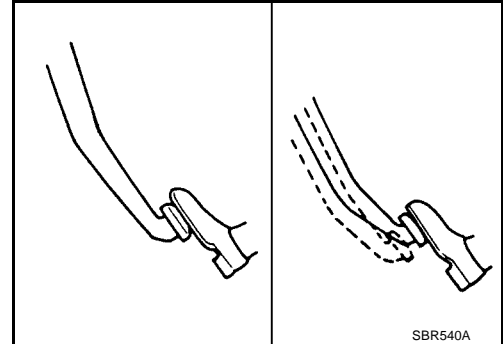
**3. CHECK CONNECTOR AND BRAKING PERFORMANCE**

1. Disconnect ABS actuator and electric unit (control unit) connector.

2. Check brake effectiveness.

OK or NG

OK >> GO TO 4.

NG >> Perform Basic Inspection. Refer to [BRC-107, "Basic Inspection"](#) .

**4. CHECK WHEEL SENSORS**

Check the following.

- Wheel sensor mounting for looseness
- Wheel sensors for physical damage
- Wheel sensor connectors for terminal damage or loose connections

OK or NG

OK >> Check ABS actuator and electric unit (control unit) pin terminals for damage and the connection of harness connector. Reconnect ABS actuator and electric unit (control unit) harness connector. Then retest.

NG >> Repair as necessary.

## Long Stopping Distance

### 1. CHECK BASE BRAKING SYSTEM PERFORMANCE

---

1. Disable ABS by disconnecting ABS actuator and electric unit (control unit) connector.
2. Drive vehicle and check to see if stopping distance is still long.

#### OK or NG

- OK >> Go to [BRC-130, "ABS Works Frequently"](#) .  
 NG >> Perform Basic Inspection. Refer to [BRC-107, "Basic Inspection"](#) .

#### NOTE:

Stopping distance may be longer than vehicles without ABS when road condition is slippery.

## ABS Does Not Work

#### CAUTION:

The ABS does not operate when the vehicle speed is 10 km/h (6 MPH) or less.

### 1. CHECK WARNING LAMP ACTIVATION

---

Turn ignition switch ON and check for warning lamp activation.

- Warning lamp should activate for approximately 1 second after turning the ignition switch ON.

#### OK or NG

- OK >> Carry out self-diagnosis. Refer to [BRC-112, "SELF-DIAGNOSIS"](#) .  
 NG >> Go to [BRC-133, "ABS Warning Lamp Does Not Come On When Ignition Switch Is Turned On"](#) .

## Pedal Vibration or ABS Operation Noise

#### NOTE:

During ABS activation, pedal vibration may be felt and a noise may be heard. This is normal and does not indicate a malfunction.

### 1. CHECK SYMPTOM

---

1. Apply brake.
2. Start engine.

Does the symptom occur only when engine is started?

- Yes >> Carry out self-diagnosis. Refer to [BRC-112, "SELF-DIAGNOSIS"](#) .  
 No >> GO TO 2.

### 2. RECHECK SYMPTOM

---

Does the symptom occur only when electrical equipment switches (such as headlamp) are turned on?

- Yes >> Check for radio, antenna or related wiring that is routed too close to the ABS actuator and electric unit (control unit) and reroute as necessary.  
 No >> Go to [BRC-130, "ABS Works Frequently"](#) .

**ABS Warning Lamp Does Not Come On When Ignition Switch Is Turned On** EFS002XU

**1. CHECK ABS ACTUATOR AND ELECTRIC UNIT (CONTROL UNIT) FUSES**

Check 40A fusible link **i** and 50A fusible link **j** for ABS actuator and electric unit (control unit). For fusible link layout, refer to [PG-3, "POWER SUPPLY ROUTING CIRCUIT"](#).

OK or NG

OK >> GO TO 2.

NG >> If fusible link is blown, be sure to eliminate cause of problem before replacing.

**2. CHECK ABS ACTUATOR AND ELECTRIC UNIT (CONTROL UNIT) POWER SUPPLY CIRCUITS**

1. Disconnect ABS actuator and electric unit (control unit) connector.
2. Check voltage between ABS actuator connector terminal 1 and ground and terminal 16 and ground.

Does battery voltage exist?

Yes >> GO TO 3.

No >> Repair harness or connectors between fusible link and ABS actuator and electric unit (control unit).

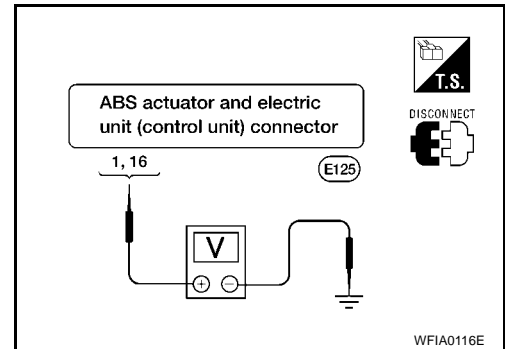

**3. CHECK ABS ACTUATOR AND ELECTRIC UNIT (CONTROL UNIT) GROUND CIRCUIT**

Check continuity between ABS actuator connector terminal 31 and ground and terminal 46 and ground.

Does continuity exist?

Yes >> Replace ABS actuator and electric unit (control unit).

No >> Repair harness or connectors between ABS actuator and electric unit (control unit) and ground.

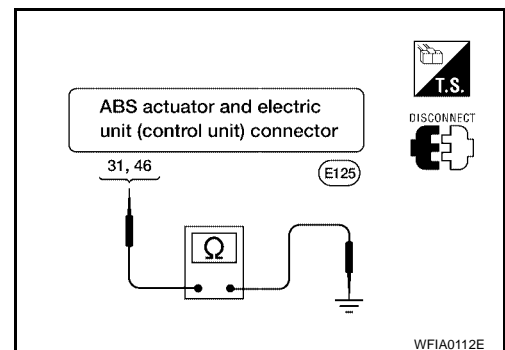

**ABS Warning Lamp Stays On When Ignition Switch Is Turned On** EFS002XV

**1. CARRY OUT SELF-DIAGNOSIS**

Carry out self-diagnosis. Refer to [BRC-112, "SELF-DIAGNOSIS"](#).

Are malfunctions detected in self-diagnosis?

Yes >> Refer to [BRC-115, "Display Item List"](#).

No >> Refer to [DI-41, "WARNING LAMPS"](#).

---

## Vehicle Jerks During TCS/VDC Activation

---

### 1. ABS ACTUATOR AND ELECTRIC UNIT (CONTROL UNIT) SELF-DIAGNOSIS

---

Perform ABS actuator and electric unit (control unit) self-diagnosis.

Are self-diagnosis result items displayed?

- Yes >> After checking and repairing the applicable item, perform the ABS actuator and electric unit (control unit) self-diagnosis again.
- No >> GO TO 2.

---

### 2. ENGINE SPEED SIGNAL INSPECTION

---

Perform data monitor with CONSULT-II for the ABS actuator and electric unit (control unit).

Is the engine speed at idle 400 rpm or higher?

- Yes >> GO TO 4.
- No >> GO TO 3.

---

### 3. ECM SELF-DIAGNOSIS

---

Perform ECM self-diagnosis.

Are self-diagnosis result items displayed?

- Yes >> After checking and repairing the applicable item, perform the ECM self-diagnosis again.
- No >> GO TO 4.

---

### 4. TCM SELF-DIAGNOSIS

---

Perform TCM self-diagnosis.

Are self-diagnosis result items displayed?

- Yes >> After checking and repairing the applicable item, perform the ECM self-diagnosis again.
- No >> GO TO 5.

---

### 5. CONNECTOR INSPECTION

---

Disconnect the ABS actuator and electric unit (control unit) connector and the ECM connectors and check the terminals for deformation, disconnection, looseness or damage.

OK or NG

- OK >> GO TO 6.
- NG >> Repair or replace the connector terminal.

---

### 6. CAN COMMUNICATION INSPECTION

---

Check the CAN communication system. Refer to [BRC-128, "CAN Communication System Inspection"](#).

OK or NG

- OK >> **INSPECTION END.**
- NG >> Reconnect the connectors, and perform ABS actuator and electric unit (control unit) self-diagnosis.

## ON-VEHICLE SERVICE

## Adjustment of Steering Angle Sensor Neutral Position

EFS002TF

After removing/installing or replacing ABS actuator and electric unit (control unit), steering angle sensor, steering components, suspension components, tires, or after adjusting wheel alignment, be sure to adjust neutral position of steering angle sensor before running vehicle.

**NOTE:**

Adjustment of steering angle sensor neutral position requires CONSULT-II.

1. Stop vehicle with front wheels in straight-ahead position.
2. Connect CONSULT-II to data link connector on vehicle, and turn ignition switch ON (do not start engine).
3. Touch "ABS", "WORK SUPPORT" and "ST ANGLE SENSOR ADJUSTMENT" on CONSULT-II screen in this order.

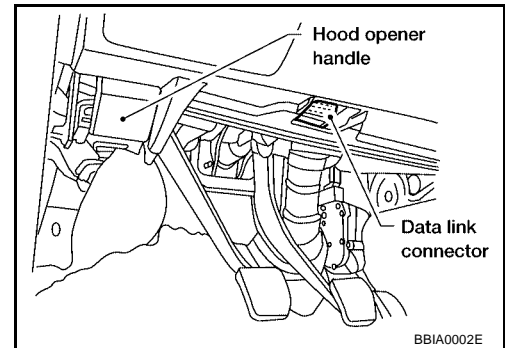

4. Touch "START".

**CAUTION:**

**Do not touch steering wheel while adjusting steering angle sensor.**

5. After approximately 10 seconds, touch "END". (After approximately 60 seconds, it ends automatically.)
6. Turn ignition switch OFF, then turn it ON again.
7. Run vehicle with front wheels in straight-ahead position, then stop.
8. Select "DATA MONITOR", "SELECTION FROM MENU", and "STR ANGLE SIG" on CONSULT-II screen. Then check that "STR ANGLE SIG" is within  $0 \pm 2.5$  deg. If value is more than specification, repeat steps 1 to 5.
9. Erase memory of ABS actuator and electric unit (control unit) and ECM.
10. Turn ignition switch to OFF.

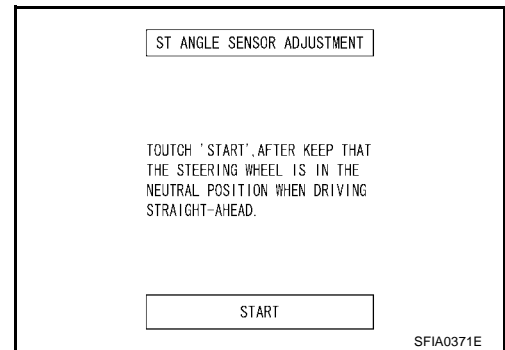

## WHEEL SENSORS

## Removal and Installation

EFS002W6

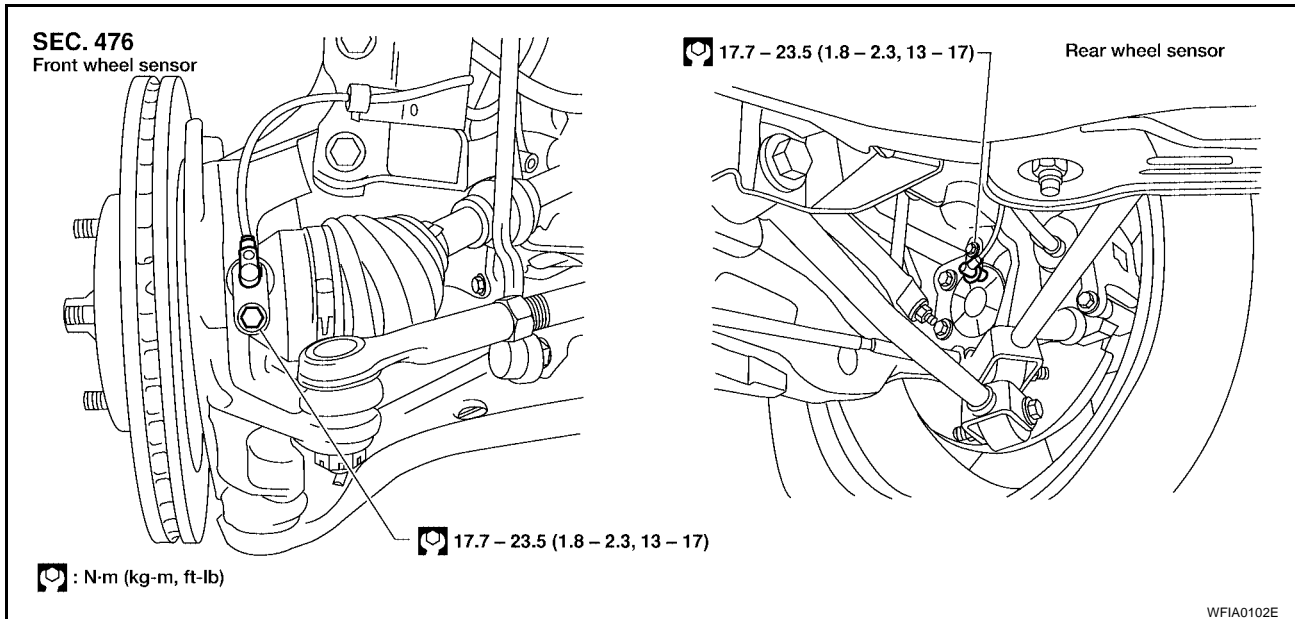
**CAUTION:**

**Be careful not to damage sensor edge and sensor rotor teeth.**

When removing the front or rear wheel hub assembly, first remove the ABS wheel sensor from the assembly. Failure to do so may result in damage to the sensor wires making the sensor inoperative.

**CAUTION:**

**Pull out the sensor being careful to turn it as little as possible. Do not pull on the sensor harness. Installation should be performed while paying attention to the following, and then tighten fasteners to the specified torque.**

- Before installing wheel sensor, make sure no foreign materials (such as iron fragments) are adhered to the pick-up part of the sensor, to the inside of the sensor mounting hole or on the rotor mounting surface.



## SENSOR ROTOR

### Removal and Installation

#### NOTE:

The rear wheel sensor rotor is built into the rear wheel hub. For removal and installation procedure, refer to [RAX-6, "Removal and Installation"](#) .

#### REMOVAL

1. Remove the front wheel hub. Refer to [FAX-6, "Removal and Installation"](#) .
2. Remove the sensor rotor using suitable puller.

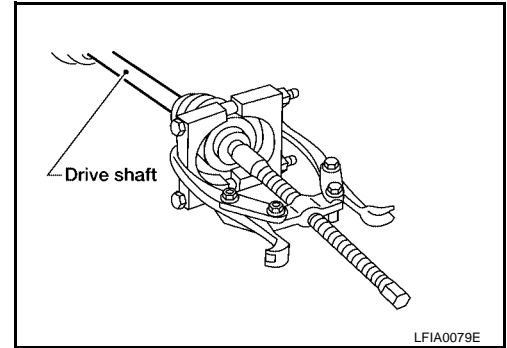

#### INSTALLATION

Install the sensor rotor using a hammer and a wooden block.

- Always replace sensor rotor with new one.

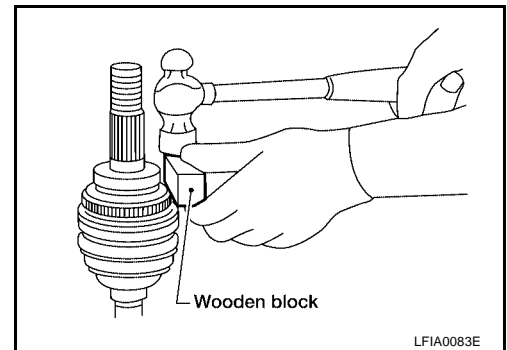

A  
B  
C  
D  
E  
BRC  
G  
H  
I  
J  
K  
L  
M

## ACTUATOR AND ELECTRIC UNIT (ASSEMBLY)

PF:47660

### Removal and Installation

EFS002WA

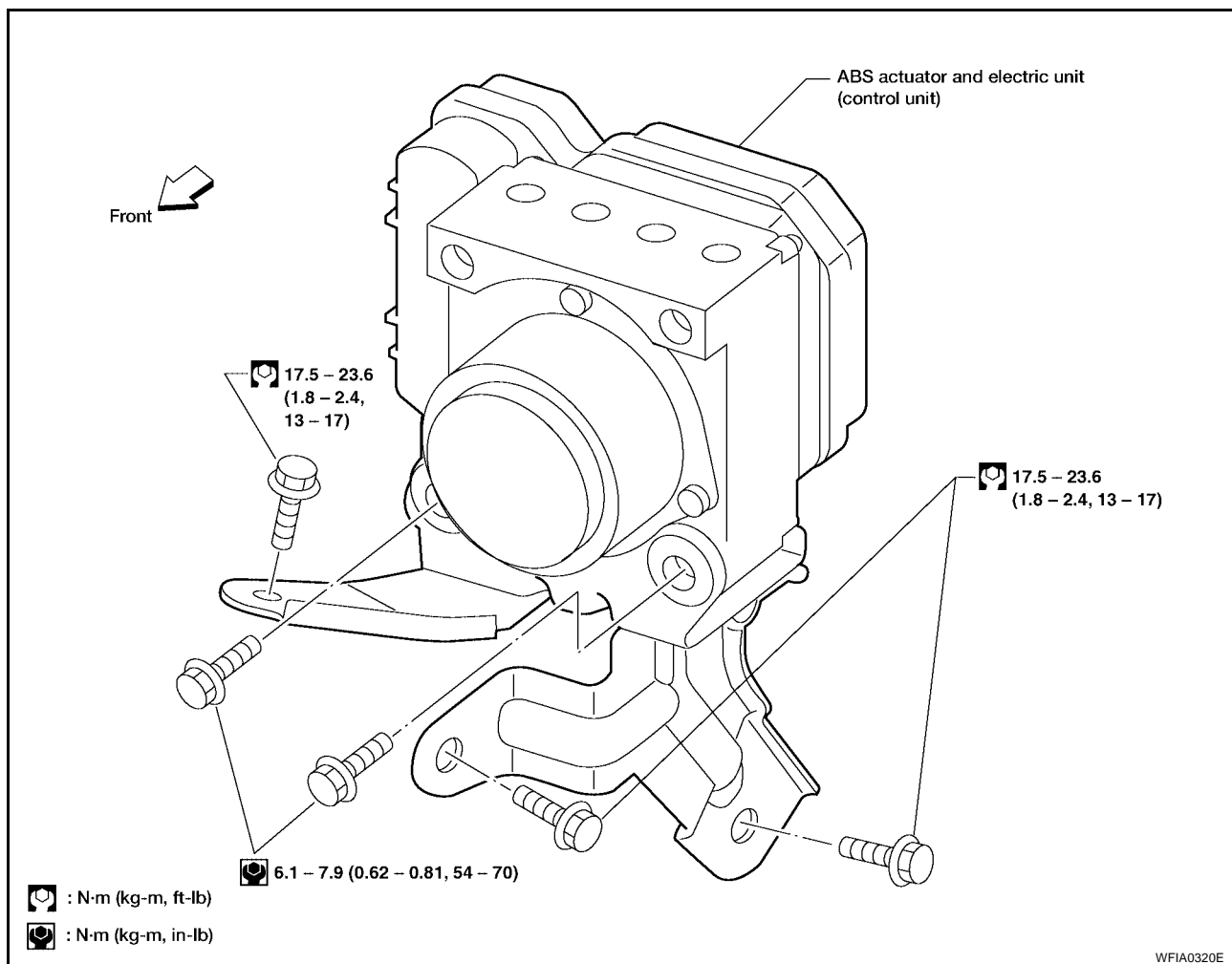

### REMOVAL

1. Disconnect battery cable.
2. Remove windshield wiper and linkage assembly. Refer to [WW-26, "REMOVAL"](#).
3. Drain brake fluid. Refer to [BR-8, "Changing Brake Fluid"](#).
4. Discharge the A/C refrigerant. Refer to [ATC-116, "HFC-134a \(R-134a\) Service Procedure"](#).
5. Disconnect and remove high-pressure and low-pressure A/C pipes to allow access to ABS actuator and electric unit (control unit). Refer to [ATC-118, "Components"](#).
6. Disconnect harness connectors from ABS actuator and electric unit (control unit).
7. Disconnect brake pipes.
8. Remove fasteners for ABS actuator and electric unit (control unit) and remove from vehicle.

### INSTALLATION

#### CAUTION:

After installation of ABS actuator and electric unit (control unit), refill brake fluid. Then bleed air from system. Refer to [BR-8, "Bleeding Brake System"](#).

1. Position ABS actuator and electric unit (control unit) in vehicle.
2. Connect brake pipes and fasteners temporarily.
3. Tighten fasteners and brake pipes.
4. Connect ABS actuator and electric unit (control unit) harness connectors.
5. Install and connect high-pressure and low-pressure A/C pipes. Refer to [ATC-118, "Components"](#).
6. Install windshield wiper and linkage assembly. Refer to [WW-27, "INSTALLATION"](#).

# ACTUATOR AND ELECTRIC UNIT (ASSEMBLY)

[VDC/TCS/ABS]

- 
7. Reconnect battery cable.
  8. Evacuate and recharge the A/C system. Refer to [ATC-116, "HFC-134a \(R-134a\) Service Procedure"](#) .
  9. Adjust the steering angle sensor. Refer to [BRC-135, "Adjustment of Steering Angle Sensor Neutral Position"](#) .

A

B

C

D

E

**BRC**

G

H

I

J

K

L

M

---

## STEERING ANGLE SENSOR

PF2:25554

### Removal and Installation

EF50031B

Refer to [SRS-43, "Removal and Installation"](#) .

**G SENSOR****Removal and Installation****REMOVAL**

1. Remove center console. Refer to [IP-17, "Center Console"](#).
2. Disconnect harness connector.
3. Remove attaching nuts and remove yaw rate/side/decel G sensor.

**CAUTION:**

- Do not drop or strike the yaw rate/side/decel G sensor.
- Do not use power tools to remove or install yaw rate/side/decel G sensor.

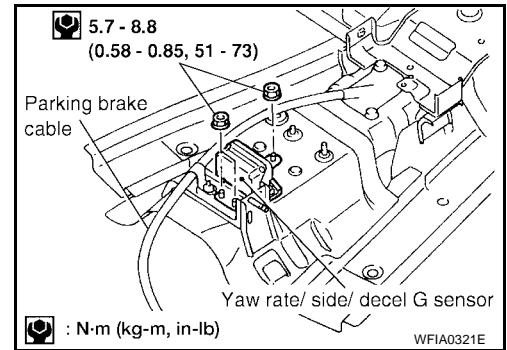
**INSTALLATION**

To install, reverse the removal procedure.

**CAUTION:**

- Do not drop or strike the yaw rate/side/decel G sensor.

A  
B  
C  
D  
E

BRC

G  
H  
I  
J  
K  
L  
M

