

A  
B  
CL  
D  
E  
F  
G  
H  
I  
J  
K  
L  
M

**SECTION CL**  
**CLUTCH**

**CONTENTS**

<b>PRECAUTIONS</b> .....	<b>2</b>	<b>INSTALLATION</b> .....	<b>10</b>
Precautions .....	2	Disassembly and Assembly .....	11
<b>PREPARATION</b> .....	<b>3</b>	DISASSEMBLY .....	11
Special Service Tools .....	3	INSPECTION AFTER DISASSEMBLY .....	11
Commercial Service Tools .....	3	ASSEMBLY .....	11
<b>NOISE, VIBRATION, AND HARSHNESS (NVH)</b>		<b>CLUTCH PIPING</b> .....	<b>12</b>
<b>TROUBLESHOOTING</b> .....	<b>4</b>	Removal and Installation .....	12
NVH TROUBLESHOOTING CHART .....	4	REMOVAL .....	12
<b>CLUTCH PEDAL</b> .....	<b>5</b>	INSTALLATION .....	12
Components .....	5	<b>CLUTCH RELEASE MECHANISM</b> .....	<b>13</b>
Removal and Installation .....	5	Removal and Installation .....	13
REMOVAL .....	5	REMOVAL .....	13
INSPECTION AFTER REMOVAL .....	5	INSPECTION AFTER REMOVAL .....	13
INSTALLATION .....	5	INSTALLATION .....	14
On-vehicle Inspection and Adjustment .....	6	<b>CLUTCH DISC, CLUTCH COVER AND FLYWHEEL..</b>	<b>15</b>
<b>CLUTCH FLUID</b> .....	<b>7</b>	Removal and Installation .....	15
Air Bleeding Procedure .....	7	REMOVAL .....	15
<b>CLUTCH MASTER CYLINDER</b> .....	<b>8</b>	INSTALLATION .....	15
Removal and Installation .....	8	Inspection and Adjustment after Removal .....	16
REMOVAL .....	8	CLUTCH DISC .....	16
INSTALLATION .....	8	CLUTCH COVER .....	16
Disassembly and Assembly .....	9	FLYWHEEL .....	16
DISASSEMBLY .....	9	<b>SERVICE DATA AND SPECIFICATIONS (SDS) .....</b>	<b>17</b>
INSPECTION AFTER DISASSEMBLY .....	9	Clutch Control System .....	17
ASSEMBLY .....	9	Clutch Master Cylinder .....	17
<b>OPERATING CYLINDER</b> .....	<b>10</b>	Clutch Operating Cylinder .....	17
Removal and Installation .....	10	Clutch Disc .....	17
REMOVAL .....	10	Clutch Cover .....	17
		Clutch Pedal .....	17

# PRECAUTIONS

## PRECAUTIONS

PFP:00001

### Precautions

ECS006JC

- Recommended fluid is brake fluid “DOT 3”.
- Never reuse drained brake fluid.
- Be careful not to splash brake fluid on painted areas.
- When removing and installing clutch piping, use Tool.
- Use new brake fluid to clean or wash all parts of master cylinder and operating cylinder.
- Never use mineral oils such as gasoline or kerosene. It will ruin the rubber parts of the hydraulic system.

**WARNING:**

After cleaning clutch disc, wipe it with a dust collector. Do not use compressed air.

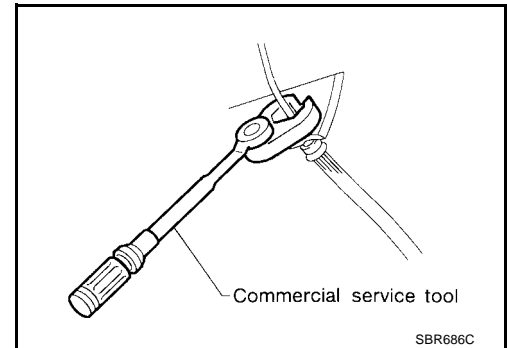

# PREPARATION

## PREPARATION

PFP:00002

### Special Service Tools

ECS006JD

The actual shapes of Kent-Moore tools may differ from those of special service tools illustrated here.

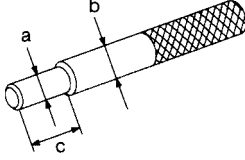
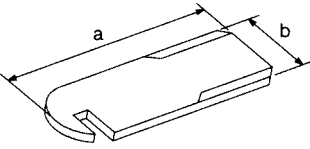
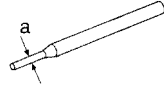
Tool number (Kent-Moore No.) Tool name	Description	
ST20630000 (J26366) Clutch aligning bar	 <p style="text-align: center;">NT405</p>	Installing clutch cover and clutch disc <b>a: 15.8 mm (0.622 in) dia.</b> <b>b: 22.9 mm (0.902 in) dia.</b> <b>c: 45.0 mm (1.772 in)</b>
ST20050240 ( — ) Diaphragm spring adjusting wrench	 <p style="text-align: center;">NT404</p>	Adjusting unevenness of diaphragm spring of clutch cover <b>a: 150 mm (5.91 in)</b> <b>b: 25 mm (0.98 in)</b>
KV32101000 (J25689-A) Pin punch	 <p style="text-align: center;">NT410</p>	Removing and installing spring pin <b>a: 4 mm (0.16 in) dia.</b>

### Commercial Service Tools

ECS006JE

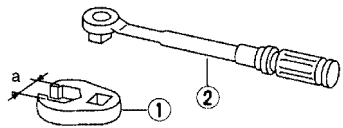
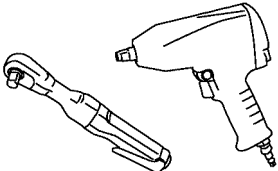
Tool name	Description	
1 Flare nut crowfoot 2 Torque wrench	 <p style="text-align: center;">NT360</p>	Removing and installing clutch piping <b>a: 10 mm (0.39 in)</b>
Power tool	 <p style="text-align: center;">PBIC0190E</p>	Loosening bolts and nuts

# NOISE, VIBRATION, AND HARSHNESS (NVH) TROUBLESHOOTING

## NOISE, VIBRATION, AND HARSHNESS (NVH) TROUBLESHOOTING

PF0:00003

### NVH TROUBLESHOOTING CHART

ECS006JF

Use the chart below to help you find the cause of the symptom. The numbers indicate the order of the inspection. If necessary, repair or replace these parts.

Symptom		SUSPECTED PARTS (Possible cause)																Reference page			
		CLUTCH PEDAL (Inspection and adjustment)	CLUTCH LINE (Air in line)	MASTER CYLINDER PISTON CUP (Damaged)	OPERATING CYLINDER PISTON CUP (Damaged)	ENGINE MOUNTING (Loose)	RELEASE BEARING (Worn, dirty or damaged)	CLUTCH DISC (Out of true)	CLUTCH DISC (Runout is excessive)	CLUTCH DISC (Lining broken)	CLUTCH DISC (Dirty or burned)	CLUTCH DISC (Oily)	CLUTCH DISC (Worn out)	CLUTCH DISC (Hardened)	CLUTCH DISC (Lack of spline grease)	DIAPHRAGM SPRING (Damaged)	DIAPHRAGM SPRING (Out of tip alignment)	PRESSURE PLATE (Distortion)	FLYWHEEL (Distortion)		
Symptom	Clutch grabs/chatters					1															
	Clutch pedal spongy		1	2	2																
	Clutch noisy						1														
	Clutch slips	1										2	2				3		4	5	
	Clutch does not disengage	1	2	3	4				5	5	5	5	5		5	6	6	7			
																					<a href="#">CL-16, "FLYWHEEL"</a>

# CLUTCH PEDAL

PF:46540

ECS006JG

## CLUTCH PEDAL

### Components

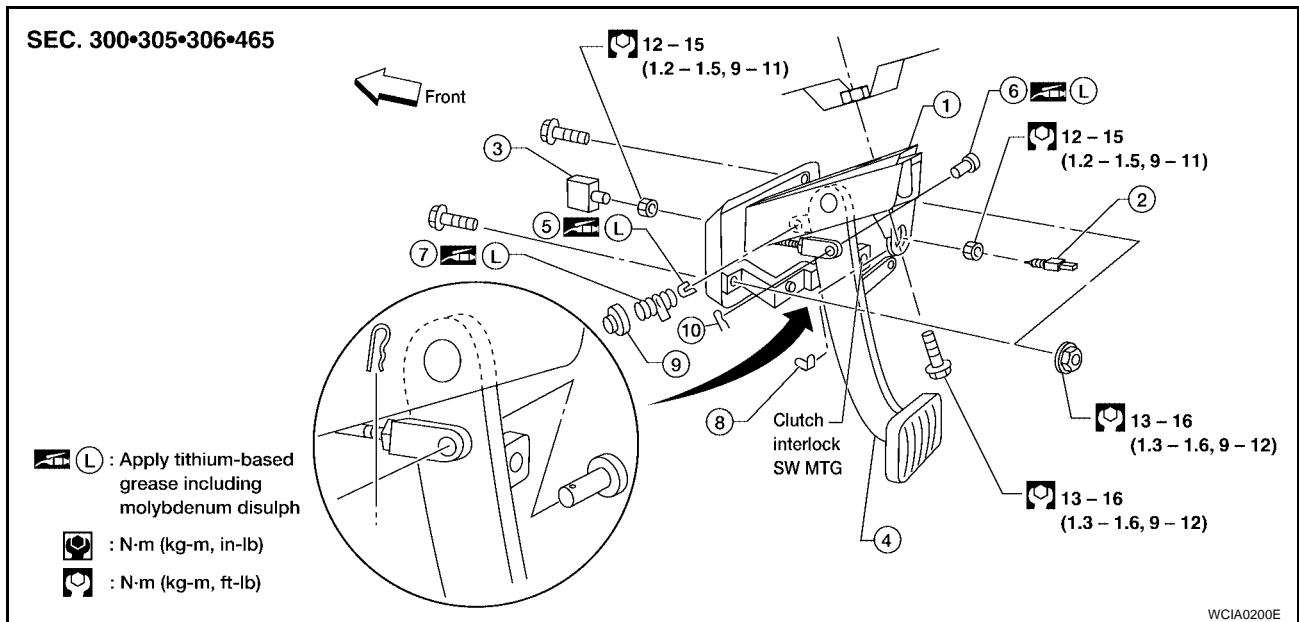

- |                         |                       |                            |
|-------------------------|-----------------------|----------------------------|
| 1. Clutch pedal bracket | 2. ASCD clutch switch | 3. Clutch interlock switch |
| 4. Clutch pedal         | 5. Bushing            | 6. Clevis pin              |
| 7. Assist spring        | 8. Stopper rubber     | 9. Bush                    |
| 10. Snap pin            |                       |                            |

## Removal and Installation

### REMOVAL

ECS006JH

1. Remove the driver side lower instrument panel. Refer to [IP-14, "Lower Driver Instrument Panel"](#).
2. Disconnect the ASCD clutch switch and the clutch interlock switch. Refer to [PG-61, "HARNESS CONNECTOR"](#).
3. Remove the clutch pedal clevis pin.
4. Remove clutch pedal assembly mounting bolts and nuts.
5. Remove clutch pedal assembly.

### INSPECTION AFTER REMOVAL

- Inspect for clutch bending, damage and welding cracks. Replace if necessary.
- Make sure that the assist spring and return spring have not lost their spring. Replace if necessary.

### INSTALLATION

Installation is in the reverse order of removal.

- After installation, refer to [CL-6, "On-vehicle Inspection and Adjustment"](#).

# CLUTCH PEDAL

ECS006/JI

## On-vehicle Inspection and Adjustment

1. Check to see if the clutch pedal clevis pin floats freely in the bore of the clutch pedal. It should not be bound by the clevis or clutch pedal.
  - a. If the pin is not free, check that the ASCD switch or pedal stopper bolt is not applying pressure to the clutch pedal causing the pin to bind. To adjust, loosen the ASCD switch or pedal stopper bolt lock nut and turn the ASCD switch or pedal stopper bolt.
  - b. Tighten the lock nut.
  - c. Verify that the clutch pedal clevis pin floats freely in the bore of the clutch pedal. It should not be bound by the clevis or clutch pedal.
  - d. If the pin is still not free, remove the pin and check for deformation or damage. Replace the pin if necessary. Leave the pin removed for step 2.
2. Check the clutch pedal stroke for free range of movement.
  - a. With the clutch pedal clevis pin removed, manually move the pedal up and down to determine if it moves freely.
  - b. If any sticking is noted, replace the related parts (clutch pedal, pedal bracket, assist spring and bushing). Reassemble the pedal and re-verify that the clevis pin floats freely in the bore of the pedal.
3. Adjust the clearance "C" while fully depressing the clutch pedal (with the clutch interlock switch) as shown.

**Clearance "C" : 0.1 – 1.0 mm (0.004 – 0.039 in)**

4. Check the clutch hydraulic system components (clutch master cylinder, clutch operating cylinder, clutch withdrawal lever, clutch release bearing, etc.) for sticking or binding.
  - a. If any sticking or binding is noted, repair or replace the related parts as necessary.
  - b. If any hydraulic system repair was necessary, bleed the clutch hydraulic system. Refer to [CL-7, "Air Bleeding Procedure"](#).

### NOTE:

Do not use a vacuum assist or any other type of power bleeder on this system. Use of a vacuum assist or power bleeder will not purge all of the air from the system.

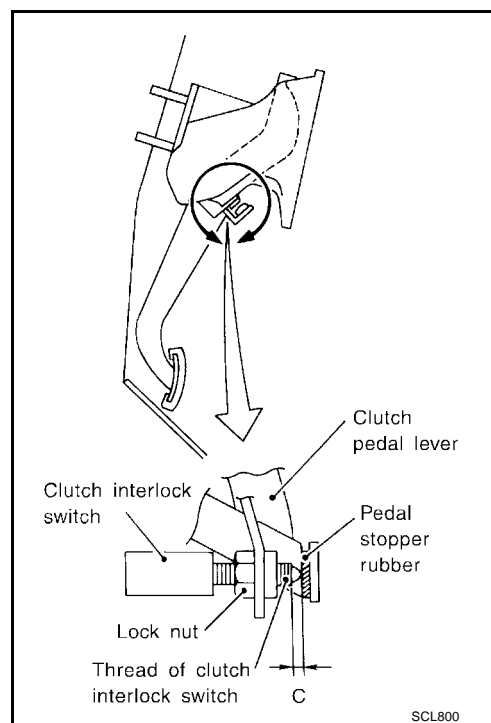
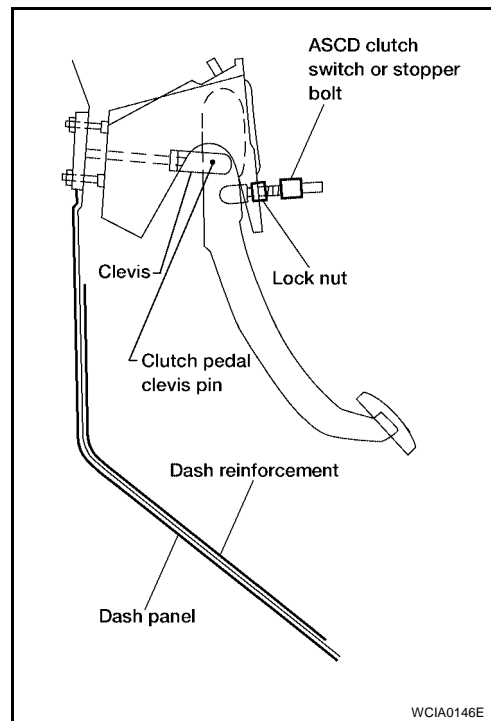

# CLUTCH FLUID

PFP:00017

## CLUTCH FLUID

### Air Bleeding Procedure

ECS006JJ

#### NOTE:

Do not use a vacuum assist or any other type of power bleeder on this system. Use of a vacuum assist or power bleeder will not purge all the air from the system.

- Bleed air according to the following procedure.
  - Carefully monitor fluid level at reservoir tank during bleeding operation.
  - When bleeding the air from the clutch fluid, first bleed the air from the operating cylinder air bleed valve and then from the bleed connector air bleed valve.
1. Top off reservoir with new recommended brake fluid.
  2. Connect a transparent vinyl tube and container to the air bleeder valve on the clutch operating cylinder.

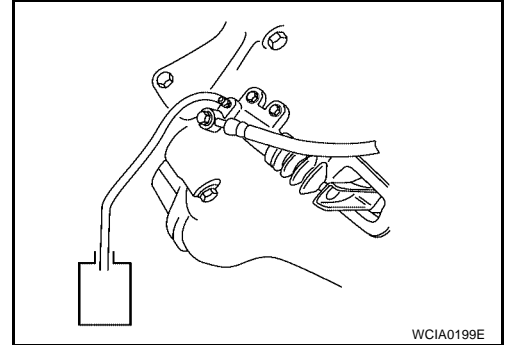

3. Fully depress the clutch pedal several times.
4. With clutch pedal depressed, open the bleeder valve to release air.
5. Close the bleeder valve.
6. Repeat steps 3 through 5 until clear brake fluid comes out of the air bleeder valve.

**Air bleeder valve : 5.9 – 9.8 N·m (0.6 – 1.0 kg·m, 52 – 87 in·lb)**

7. Perform steps 1 through 6 for bleeding air from the air bleeder valve on the bleed connector.

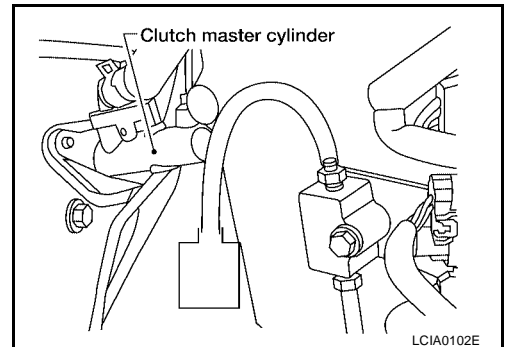

# CLUTCH MASTER CYLINDER

## CLUTCH MASTER CYLINDER

PFP:30610

### Removal and Installation

ECS006JK

SEC. 305

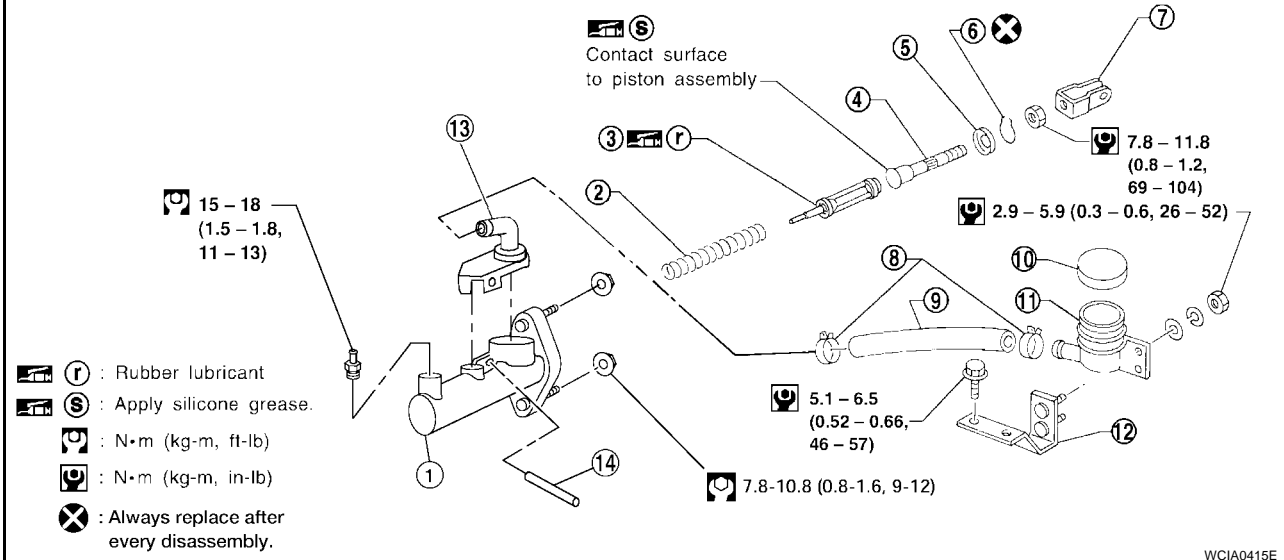

WCIA0415E

- |                           |                    |                    |
|---------------------------|--------------------|--------------------|
| 1. Clutch master cylinder | 2. Return spring   | 3. Piston assembly |
| 4. Push rod               | 5. Stopper         | 6. Stopper ring    |
| 7. Clevis                 | 8. Hose clamp      | 9. Hose            |
| 10. Reservoir cap         | 11. Reservoir tank | 12. Bracket        |
| 13. Nipple                | 14. Pin            |                    |

### REMOVAL

1. Drain the brake fluid from the clutch hydraulic system.

#### CAUTION:

**Do not to splash brake fluid on painted areas; it may cause paint damage. If brake fluid is splashed on painted areas, wash it away with water immediately.**

2. Remove clutch tube using a flare nut wrench.
3. Remove snap pin between clutch pedal and push rod, and remove clevis pin.
4. Remove the clutch master cylinder mounting nuts and reservoir tank bracket mounting bolts to remove the clutch master cylinder.

### INSTALLATION

1. Connect the clutch tube to the master cylinder assembly, and hand-tighten the flare nut.
2. Install the master cylinder assembly, and tighten the nuts to specification.

**Clutch master cylinder nuts : 7.8 - 10.8 N-m (0.8 - 1.1 kg-m, 69 - 95 in-lb)**

3. Install the clutch reservoir tank and bracket, tighten the reservoir tank and bracket nuts and bolts to specification.

**Reservoir tank bracket bolts : 5.1 - 6.5 N-m (0.52 - 0.66 kg-m, 45.1 - 57.3 in-lb)**

**Reservoir tank to bracket nuts : 2.9 - 5.9 N-m (0.3 - 0.6 kg-m, 26 - 52 in-lb)**

4. Tighten the clutch tube flare nut to specification using a flare nut torque wrench.

**Clutch tube flare nut : 15 - 18 N-m (1.5 - 1.8 kg-m, 11 - 13 ft-lb)**

5. After installing the clevis pin, install the snap pin to connect the clutch pedal to the push rod. Then bleed the air from the clutch hydraulic system. Refer to [CL-7, "Air Bleeding Procedure"](#).



# CLUTCH MASTER CYLINDER

ECS006JL

## Disassembly and Assembly

### DISASSEMBLY

1. Loosen the push rod lock nut "A" to remove clevis and lock nut "A".
2. Remove the stopper ring and stopper, and remove the push rod from the cylinder body. During removal, keep the push rod depressed, to prevent the piston inside master cylinder from popping out.
3. Remove the piston assembly from the cylinder body.

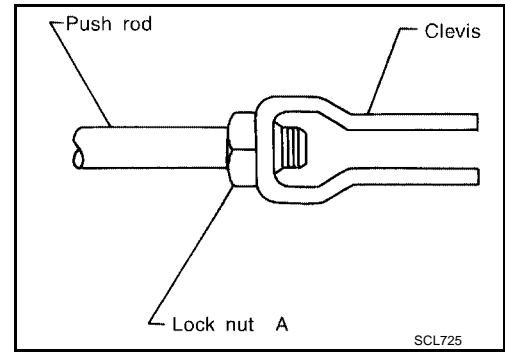

### INSPECTION AFTER DISASSEMBLY

Inspect for the following, and replace parts as necessary.

- Damage, wear, rust, and pinholes on the cylinder inner wall
- Damage and deformation of the reservoir tank
- Weak spring
- Crack and deformation of the dust cover

### ASSEMBLY

1. Apply rubber lubricant to the sliding part of piston assembly, and insert piston assembly.
2. After installing stopper to push rod, install a new stopper ring while keeping piston assembly depressed by hand, so that piston assembly will not pop out.

#### **CAUTION:**

**Stopper ring cannot be reused. Always use a new stopper ring to assemble.**

3. Install dust cover.
4. Install clevis to push rod, and tighten lock nut "A" to specification.

**Lock nut "A" tightening torque : 7.8 – 11.8 N·m (0.8 – 1.2 kg·m, 69 – 104 in·lb)**

5. Install seal and nipple to cylinder body.

A  
B  
CL  
D  
E  
F  
G  
H  
I  
J  
K  
L  
M

# OPERATING CYLINDER

PF3:30620

ECS006JM

## OPERATING CYLINDER Removal and Installation

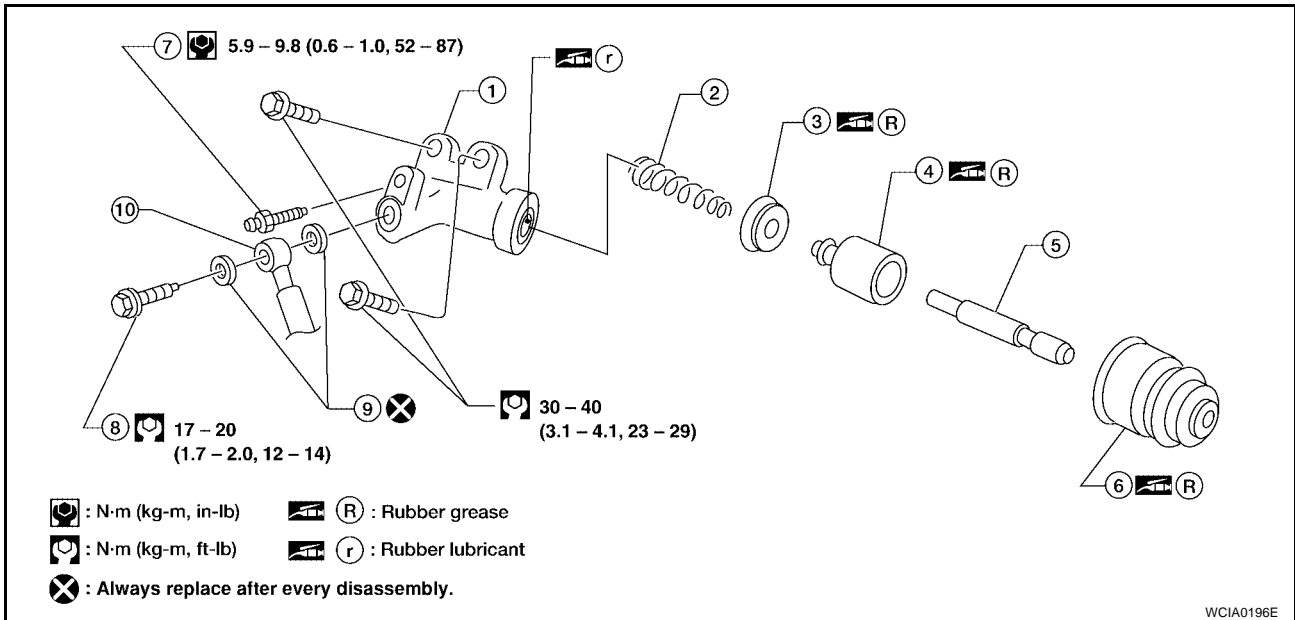

- |                  |                  |                  |
|------------------|------------------|------------------|
| 1. Cylinder body | 2. Piston spring | 3. Piston cup    |
| 4. Piston        | 5. Push rod      | 6. Dust cover    |
| 7. Air bleeder   | 8. Union bolt    | 9. Copper washer |
| 10. Clutch hose  |                  |                  |

### REMOVAL

1. Drain brake fluid from hydraulic clutch system.

#### CAUTION:

**Do not to splash brake fluid on painted areas; it may cause paint damage. If brake fluid is splashed on painted areas, wash it away with water immediately.**

2. Remove union bolt and clutch hose from operating cylinder.
3. Remove operating cylinder mounting bolts, and remove cylinder from vehicle.

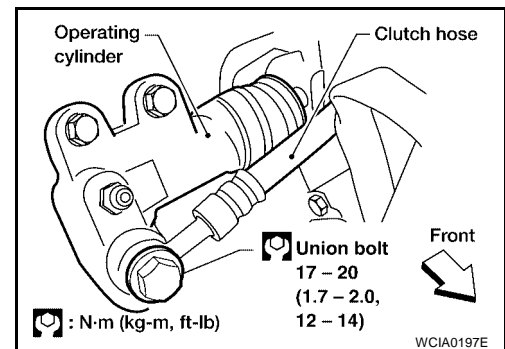

### INSTALLATION

Installation is in the reverse order of removal.

#### CAUTION:

- Install the clutch hose without twisting it.
- The copper washer of the union bolt cannot be reused. Always use a new copper washer when installing the clutch hose.
- After installation, bleed the air from the clutch hydraulic system. Refer to [CL-7. "Air Bleeding Procedure"](#).

# OPERATING CYLINDER

## Disassembly and Assembly

ECS006JN

### DISASSEMBLY

- Remove dust cover, and remove piston assembly from cylinder body.

### INSPECTION AFTER DISASSEMBLY

Inspect for following, and replace parts as necessary.

- Damage, foreign material, wear, rust, and pinholes on the cylinder inner surface, piston, and sliding part of piston cup
- Weak spring
- Crack and deformation of dust cover

### ASSEMBLY

Assembly is in the reverse order of disassembly.

- Apply recommended rubber grease to piston cup and piston before assembly.

A

B

CL

D

E

F

G

H

I

J

K

L

M

# CLUTCH PIPING

## CLUTCH PIPING

PF3:30650

### Removal and Installation

ECS006J0

#### REMOVAL

1. Remove fuel filter mounting bracket.
2. Remove air cleaner and air duct. Refer to [EM-15, "Removal and Installation"](#).
3. Drain the brake fluid from the hydraulic clutch system.

#### CAUTION:

**Do not to splash brake fluid on painted areas; it may cause paint damage. If brake fluid is splashed on painted areas, wash it away with water immediately.**

4. Remove flare nut using a flare nut wrench.
5. Remove clutch hose and clutch tube.

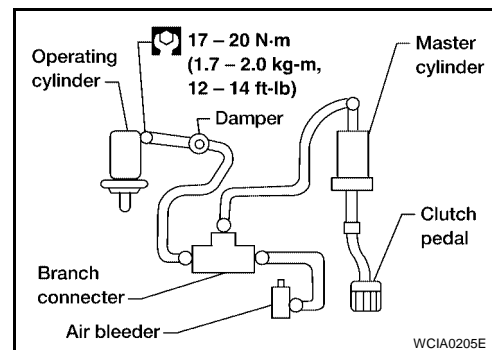

#### INSTALLATION

1. When installing clutch hose to bracket, face lock plate in the correct direction as shown to secure clutch hose.

#### CAUTION:

**Install clutch hose without twisting or bending it.**

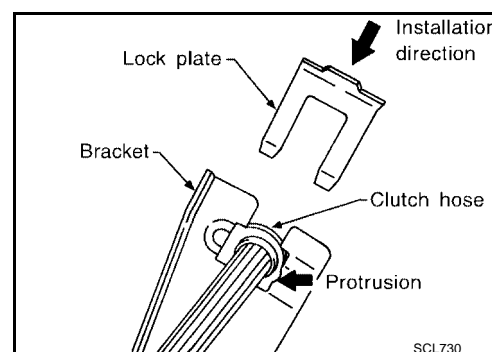

2. Tighten flare nut to the specification, using a flare nut wrench.

**Flare nut : 15 – 18 N·m (1.5 – 1.8 kg-m, 11 – 13 ft-lb)**

#### CAUTION:

**Be careful not to damage flare nut and clutch tube.**

3. Install clutch hose to operating cylinder, and tighten the union bolt to the specification.

**Clutch hose union bolt : 17 – 20 N·m (1.7 – 2.0 kg-m, 12 – 14 ft-lb)**

4. After installation, bleed the air from the clutch hydraulic system. Refer to [CL-7, "Air Bleeding Procedure"](#).

# CLUTCH RELEASE MECHANISM

PFP:30502

## CLUTCH RELEASE MECHANISM

### Removal and Installation

ECS006JP

SEC. 300

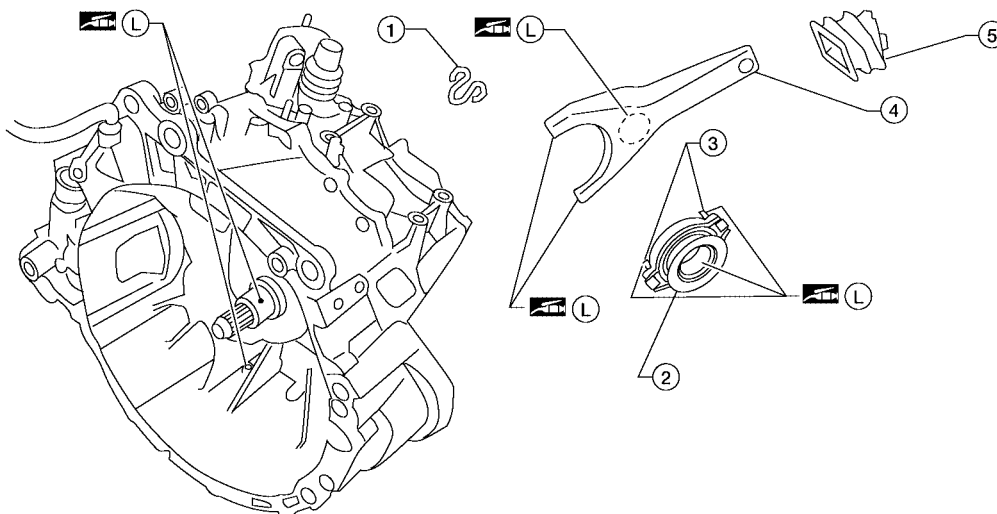

L : Apply lithium-based grease including molybdenum disulphide.

WCIA0408E

- |                     |                                      |                  |
|---------------------|--------------------------------------|------------------|
| 1. Snap spring      | 2. Release bearing non-separate type | 3. Holder spring |
| 4. Withdrawal lever | 5. Dust cover                        |                  |

#### CAUTION:

When installing the holder spring pay attention to the direction of the bearing retainer.

#### REMOVAL

1. Remove manual transaxle from vehicle. Refer to [MT-18, "Removal and Installation"](#).
2. Move withdrawal lever enough to remove release bearing from input shaft, then remove release bearing from withdrawal lever.
3. Remove withdrawal lever snap spring.
4. Pull out withdrawal lever and remove dust cover.

#### INSPECTION AFTER REMOVAL

- Replace the release bearing if it is seized, damaged, faulty in rotation direction, or has poor aligning function.
- Replace the withdrawal lever if its contact surface is worn abnormally.
- Replace the dust seal if it is deformed or cracked.

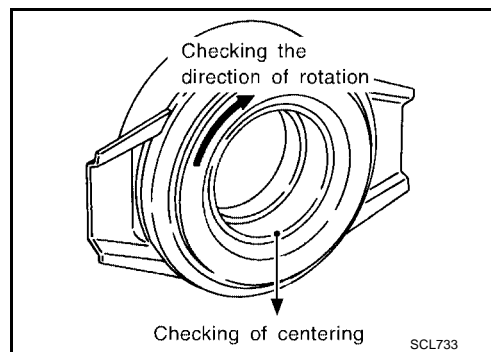

# CLUTCH RELEASE MECHANISM

## INSTALLATION

Installation is in the reverse order of removal.

### NOTE:

- Clean old grease and abrasive materials off the grease application areas.
- Apply grease to the specified points as shown.

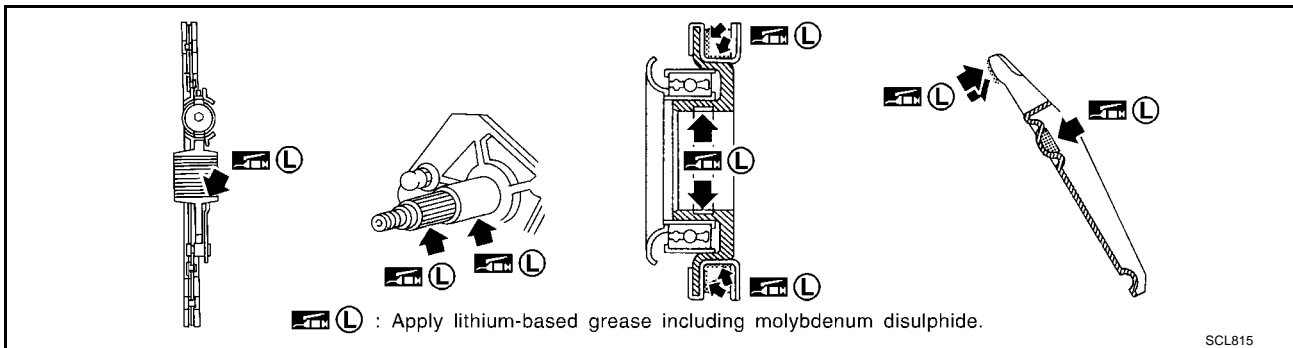

- Apply approximately 1 mm (0.04 in) thick coat of clutch sleeve grease to withdrawal lever and holder spring frictional surfaces.
- Apply a coat of clutch sleeve grease to the grooves on contact surfaces of the withdrawal lever ball pin and inner surface of release bearing; make sure that grease is flush with grooves.
- Apply a thin coat of clutch sleeve grease to release bearing frictional surface. After grease application, install release bearing. Wipe off excess grease forced out during bearing installation.

### CAUTION:

- Before installing the manual transaxle to the vehicle, check that each sliding surface slides smoothly by operating withdrawal lever.
- When assembling, make sure that both ends of the snap spring touch the end face of the withdrawal lever.
- Be careful with the orientation of the installation.

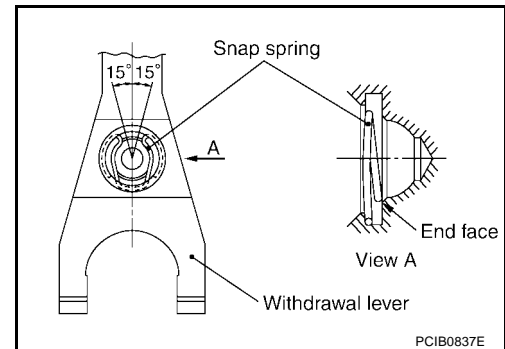

# CLUTCH DISC, CLUTCH COVER AND FLYWHEEL

## CLUTCH DISC, CLUTCH COVER AND FLYWHEEL

PF3:30100

### Removal and Installation

ECS006JQ

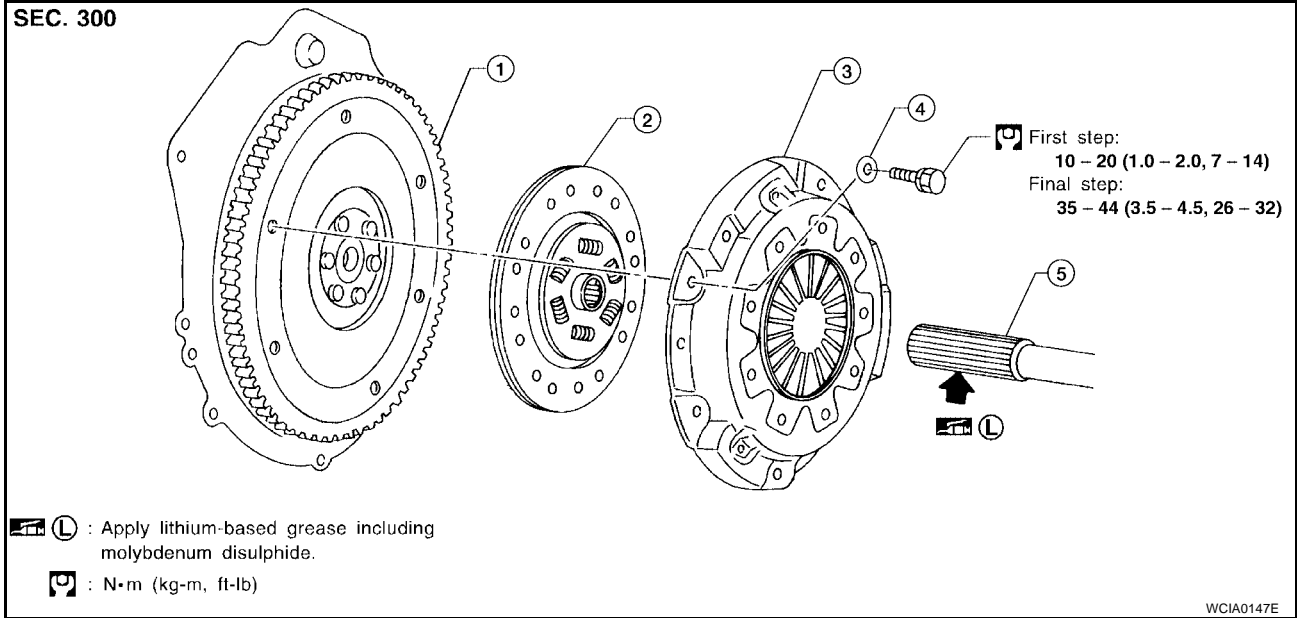

- |             |                     |                 |
|-------------|---------------------|-----------------|
| 1. Flywheel | 2. Clutch disc      | 3. Clutch cover |
| 4. Washer   | 5. Main drive shaft |                 |

#### CAUTION:

- Do not clean the clutch disc with solvent.
- When installing, do not get grease from the main drive shaft onto the clutch disc friction surface.

#### REMOVAL

1. Remove the manual transaxle from the vehicle. Refer to [MT-18, "Removal and Installation"](#).
2. Evenly loosen the bolts holding the clutch cover, using power tool. Then remove the clutch cover and the clutch disc.

#### INSTALLATION

Installation is in the reverse order of removal.

- Insert Tool into clutch disc hub when installing clutch cover and disc.
- Be careful not to allow grease to contaminate clutch facing.
- Tighten the clutch cover bolts in the numerical order as shown, in two steps.

**First step** : 10 – 20 N·m (1.0 – 2.0 kg·m, 7 – 14 ft·lb)  
**Final step** : 35 – 44 N·m (3.5 – 4.5 kg·m, 26 – 32 ft·lb)

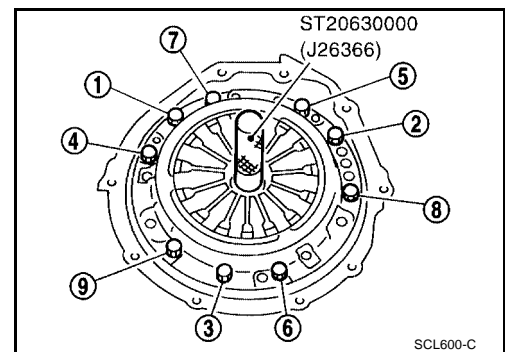

# CLUTCH DISC, CLUTCH COVER AND FLYWHEEL

ECS006JR

## Inspection and Adjustment after Removal CLUTCH DISC

- Check clutch disc for wear of facing.

**Wear limit of facing surface to rivet head : 0.3 mm (0.012 in)**

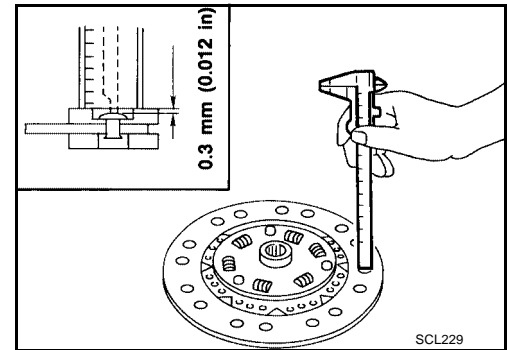

- Check clutch disc for backlash of spline and runout of facing.

**Maximum backlash of spline : 1.0 mm (0.039 in)  
(at outer edge of disc)**

**Runout limit : 0.7 mm (0.028 in)**

**Distance of runout check point : 240 mm (9.45 in)  
(from hub center)**

- Check clutch disc for burns, discoloration or oil or grease leakage. Replace if necessary.

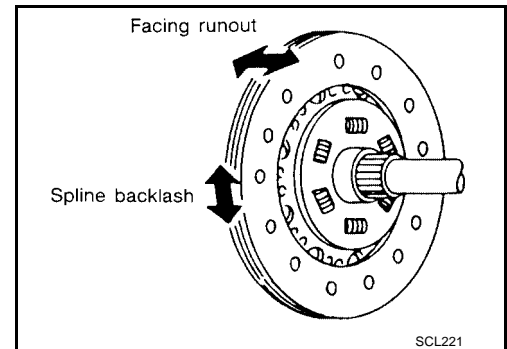

## CLUTCH COVER

- Check clutch cover installed on vehicle for unevenness of diaphragm spring toe height.

**Uneven limit : 1.0 mm (0.039 in)**

- If out of limit, adjust the height using Tool.

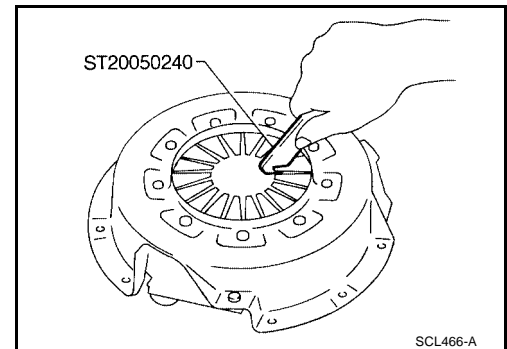

## FLYWHEEL

- Check contact surface of flywheel for slight burns or discoloration. Repair flywheel with emery paper.
- Check the flywheel runout. Refer to [EM-147, "FLYWHEEL RUNOUT \(M/T\)"](#).

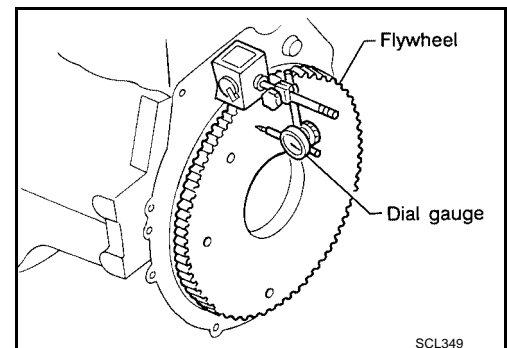



# SERVICE DATA AND SPECIFICATIONS (SDS)

## SERVICE DATA AND SPECIFICATIONS (SDS)

PF00:00100

### Clutch Control System

ECS006JS

Type of clutch control	Hydraulic
------------------------	-----------

### Clutch Master Cylinder

ECS006JT

Unit: mm (in)

Inner diameter	15.87 (5/8)
----------------	-------------

### Clutch Operating Cylinder

ECS006JU

Unit: mm (in)

Inner diameter	17.46 (11/16)
----------------	---------------

### Clutch Disc

ECS006JV

Model	250
Facing size (Outer dia. × inner dia. × thickness)	250 mm × 170 mm × 3.2 mm (9.84 in × 6.69 in × 0.126 in)
Thickness of disc assembly With load	7.4 mm (0.291 in) with 8,340 N (850 kg, 1,875 lb)
Wear limit of facing surface to rivet head	0.3 mm (0.012 in)
Facing runout limit	0.7 mm (0.028 in)
Distance of runout check point (from the hub center)	240 mm (9.45 in)
Maximum spline backlash (at outer edge of disc)	1.0 mm (0.039 in)

### Clutch Cover

ECS006JW

Model	250
Set load	8,340 N (850 kg, 1,875 lb)
Set height	40.5 mm (1.59 in)
Uneven limit of diaphragm spring toe height	1.0 mm (0.039 in)

### Clutch Pedal

ECS006JX

Unit: mm (in)

Clearance "C" between pedal stopper rubber and clutch interlock switch threaded end while clutch pedal is fully depressed.	0.1 - 1.0 (0.004 - 0.039)
--	---------------------------

## SERVICE DATA AND SPECIFICATIONS (SDS)

---