

A
B
C

SECTION PB
PARKING BRAKE SYSTEM

D
E

CONTENTS

PARKING BRAKE SYSTEM	2	REMOVAL	5	PB
Components	2	INSTALLATION	5	
Removal and Installation	2	SHOE CLEARANCE ADJUSTMENT	6	
REMOVAL	2	Inspection	6	G
INSTALLATION	3	Breaking-in Drum and Lining	6	
Inspection	3	SERVICE DATA AND SPECIFICATIONS (SDS)	8	
Adjustment	3	Parking Brake Control	8	H
PARKING BRAKE SHOE	5	Parking Drum Brake	8	
Removal and Installation	5			I

PARKING BRAKE SYSTEM

PARKING BRAKE SYSTEM

PFP:36010

Components

EFS002PK

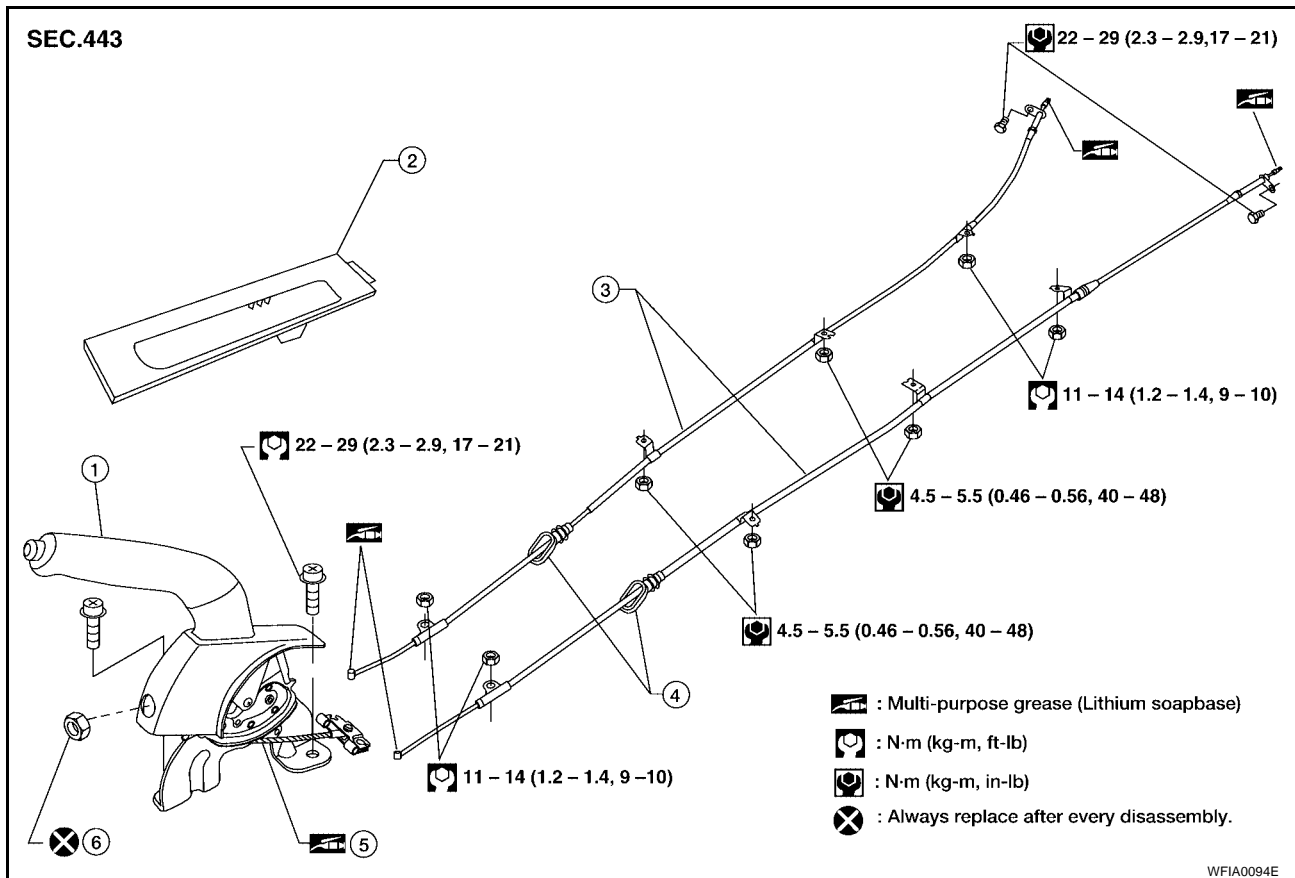

1. Control lever

2. Control lever finisher

3. Cable assembly

4. Grommet

5. Front cable

6. Adjusting nut

Removal and Installation

REMOVAL

EFS002PL

1. Remove center console. Refer to [IP-17, "Center Console"](#).
2. Disconnect warning lamp connector.
3. Remove all parking brake cable mounting nuts and bolts, loosen and remove adjusting nut.

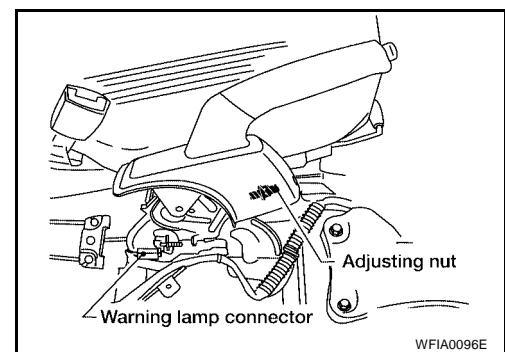

4. Remove the rear brake rotor. Refer to [BR-31, "Removal and Installation of Caliper Assembly and Disc Rotor"](#).

PARKING BRAKE SYSTEM

5. Remove the lock plate mounting bolt.
6. Remove the pin, then the parking brake cable.

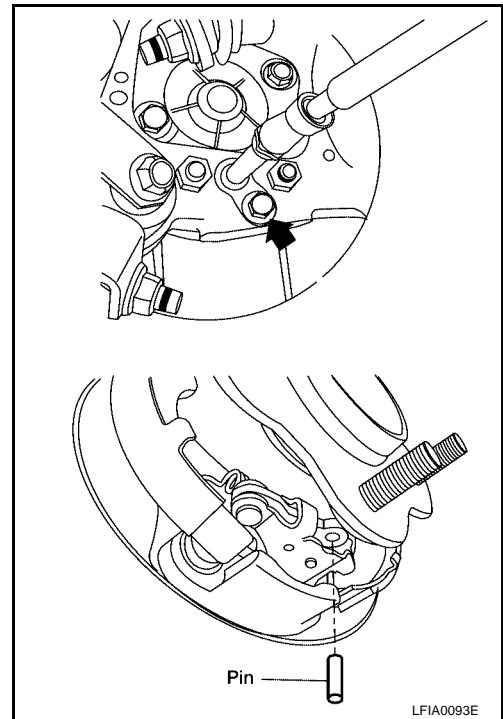

INSTALLATION

Installation is in the reverse order of removal.

- Adjust the parking brake cable. Refer to [PB-3, "Adjustment"](#) .

Inspection

- Check control lever for wear or other damage. Replace if necessary.
- Check wires for discontinuity or deterioration. Replace if necessary.
- Check warning lamp and switch. Replace if necessary.
- Check parts at each connecting portion and, if found deformed or damaged, replace.
- Check if the control lever stroke is within specification. Refer to [PB-3, "Adjustment"](#) .

Adjustment

1. Remove control lever finisher from the center console.
2. Fully engage the control lever.
3. Loosen the parking brake cable adjusting nut and fully release the control lever.
4. Adjust clearance of the rear parking brake shoes. Refer to [PB-6, "SHOE CLEARANCE ADJUSTMENT"](#) .
5. Depress the brake pedal fully more than five times.
6. Make sure that no drag exists while rotating the rear wheels.
7. Operate control lever 10 times or more with a full stroke [216 mm (8.5 in)].
8. Adjust control lever by turning adjusting nut.
9. Pull control lever with specified amount of force. Check control lever stroke and ensure smooth operation.

Lever stroke (number of notches) : 7 - 8

Force : 196 N (20 kgf, 44 lbf)

10. After adjustment, check the following points.

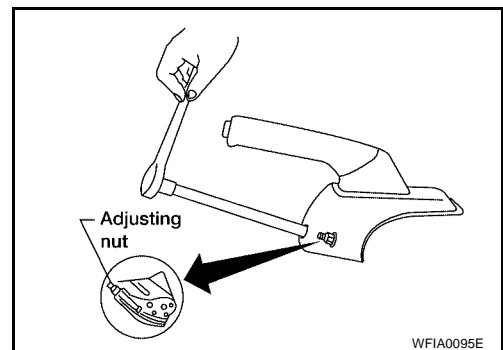

PARKING BRAKE SYSTEM

- There is no drag when control lever is being released.
- Toggle lever returns to stopper when parking brake lever is released.

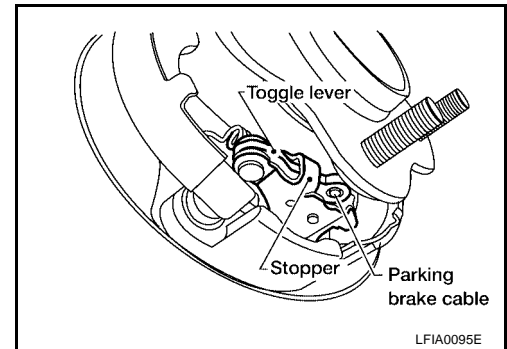

PARKING BRAKE SHOE

PFP:44060

PARKING BRAKE SHOE

Removal and Installation REMOVAL

EFS002P0

WARNING:

Clean brakes with a vacuum dust collector to minimize the hazard of airborne particles or other materials.

1. Remove the wheel and tire. Refer to [WT-4, "WHEEL AND TIRE ASSEMBLY"](#).
2. Remove the brake rotor with the parking brake lever completely disengaged.
3. If the brake rotor cannot be removed, remove as follows:
 - a. Secure the brake rotor with the wheel nut and remove the adjuster hole plug.
 - b. Insert a flat-bladed screwdriver through the plug opening and rotate the star wheel on the adjuster assembly in the direction as shown to retract the parking brake shoes.
4. Remove the parking brake shoe springs.
5. Remove the parking brake shoes and adjuster.

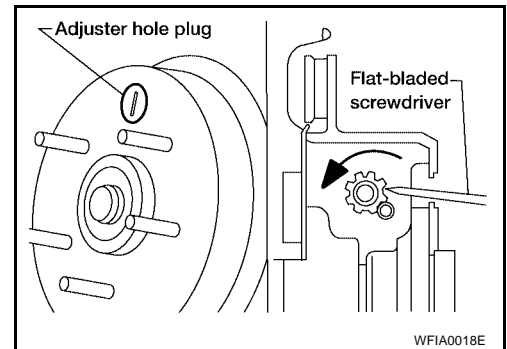

INSTALLATION

Installation is in the reverse order of removal noting the following:

- Apply brake grease to the contact areas shown. Refer to [MA-10, "RECOMMENDED FLUIDS AND LUBRICANTS"](#).
- Install the parking brake shoe springs as shown.

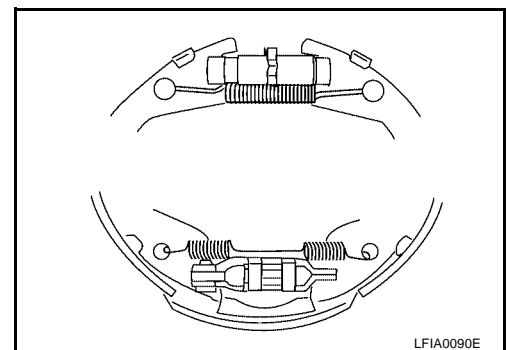
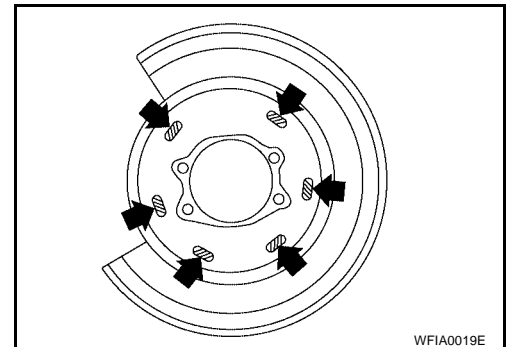

A
B
C
D
E
PB
G
H
I
J
K
L
M

PARKING BRAKE SHOE

- The orientation of the adjuster is different from left to right. Assemble the adjuster so that the threaded part is expanded when rotating it to the direction as shown. Completely retract the adjuster to assemble. When disassembling the adjuster, apply brake grease to the threads.
- After installing parking brake shoes and rotor, adjust the parking brake. Refer to [PB-6, "SHOE CLEARANCE ADJUSTMENT"](#).

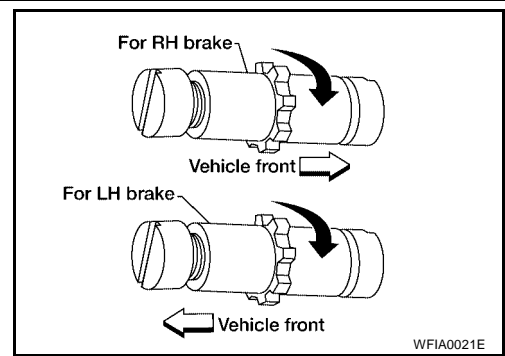

SHOE CLEARANCE ADJUSTMENT

1. Make sure the parking brake control lever is fully released and parking brake cable adjusting nut is loosened.
 2. Remove the adjuster hole plug installed on the rotor. Using a screwdriver, turn the adjuster as shown in the figure until the rotor is locked. After locking, turn the adjuster in the opposite direction 5 or 6 notches.
 3. Rotate the rotor to make sure that there is no drag. Install the adjuster hole plug.
 4. After adjusting the clearance of the rear shoes, adjust the parking brake cable. Refer to [PB-3, "Adjustment"](#).
- After replacing the shoes or the brake rotor or if the parking brake does not function well, carry out the break-in procedure. Refer to [PB-6, "Breaking-in Drum and Lining"](#).

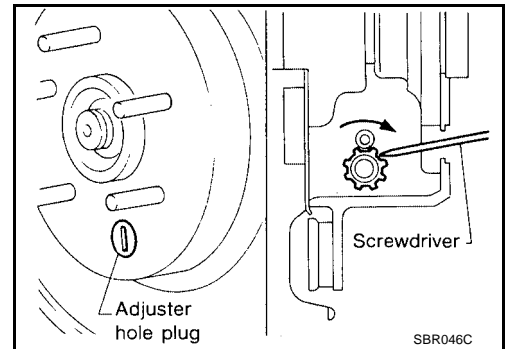

Inspection

- Visually inspect the lining for abnormal wear, damage and peeling.
- Using a micrometer, measure the thickness "A" of the lining.

Standard lining thickness : 3.2 mm (0.126 in)

Lining wear limit "A" : 1.5 mm (0.059 in)

- Visually inspect the inside of the drum for abnormal wear, damage and cracks. Using a pair of vernier calipers, measure the inside diameter of the drum.

Standard inner diameter : 172.0 mm (6.77 in)

Maximum inner diameter : 173.0 mm (6.81 in)

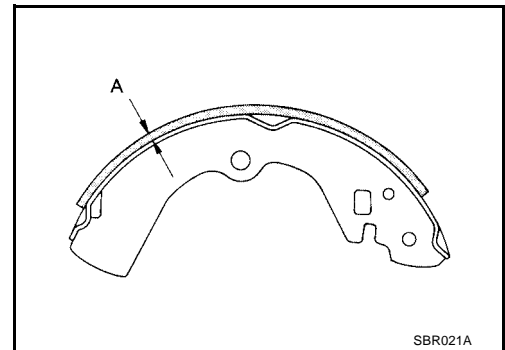

CAUTION:

If necessary, remove the parking brake shoe and check as follows.

- Check the shoe sliding surface for abnormal wear and damage.
- Check the anchor pin for abnormal wear and corrosion.
- Check the return springs for sagging.
- Check the adjuster for rough operation.

Breaking-in Drum and Lining

CAUTION:

Do not carry out the break-in procedure excessively. Doing so may cause uneven or premature wear of the brake shoe lining.

When new parking brake shoes or brake rotors are installed or when parking brake performance is poor, perform the following break-in procedure.

1. Drive the unloaded vehicle on a safe, level and dry road.
2. Pull the parking brake control lever with a force of 147 N (15 kg, 33 lb).

PARKING BRAKE SHOE

-
3. While pulling the lever, continue to drive the vehicle forward 100 meters (328 ft) at approximately 35 km/h (22 MPH). A
 4. Allow the parking brake to cool down for approximately five minutes.
 5. Release the parking brake control lever and drive the vehicle under normal conditions for two minutes to cool down the parking brake. B
 6. Repeat steps 1 through 5 three times and repeat just step 5 once more.
 7. After performing the break-in procedure, check the stroke of the parking brake control lever. If it is out of specification, adjust again. Refer to [PB-3, "Adjustment"](#) . C

A

B

C

D

E

PB

G

H

I

J

K

L

M

SERVICE DATA AND SPECIFICATIONS (SDS)

SERVICE DATA AND SPECIFICATIONS (SDS)

PFP:00030

Parking Brake Control

EFS002PR

Control type	Hand lever
Number of notches [under force of 196 N (20.4 kg, 44.9 lb)]	7 - 8
Number of notches when warning lamp switch comes on	1

Parking Drum Brake

EFS002PS

Type		DS17HF
Brake lining	Standard thickness (new)	3.2 mm (0.126 in)
	Wear limit thickness	1.5 mm (0.059 in)
Drum (disc)	Standard inner diameter (new)	172 mm (6.77 in)
	Wear limit of inner diameter	173 mm (6.81 in)