

SECTION **AV**

AUDIO, VISUAL, NAVIGATION & TELEPHONE SYSTEM

CONTENTS

PRECAUTIONS	2	Front Tweeter (Base System)	29	A
Precautions for Supplemental Restraint System (SRS) "AIR BAG" and "SEAT BELT PRE-TENSIONER"	2	Sound Is Not Heard From Rear Door Speaker (Base System)	31	B
Wiring Diagrams and Trouble Diagnosis	2	Sound Is Not Heard From Front Door Speaker or Front Tweeter (Premium System)	33	C
PREPARATION	3	Sound Is Not Heard From Rear Door Speaker or Rear Door Tweeter (Premium System)	36	D
Commercial Service Tool	3	Sound Is Not Heard From Subwoofer (Premium System)	40	E
AUDIO	4	Removal and Installation for Audio Unit	41	F
Component Parts and Harness Connector Location	4	REMOVAL	41	G
System Description	5	INSTALLATION	41	H
BASE SYSTEM	5	Removal and Installation of Speaker	41	I
PREMIUM SYSTEM	5	REMOVAL - FRONT DOOR SPEAKER	41	J
Schematic	7	INSTALLATION - FRONT DOOR SPEAKER	41	
PREMIUM SYSTEM	7	REMOVAL - REAR DOOR SPEAKER	41	
Wiring Diagram — AUDIO —	8	INSTALLATION - REAR DOOR SPEAKER	41	
BASE SYSTEM	8	REMOVAL - FRONT TWEETER	42	
PREMIUM SYSTEM	10	INSTALLATION - FRONT TWEETER	42	
Terminals and Reference Value for Audio Unit (Base System)	17	REMOVAL - REAR DOOR TWEETER (PREMIUM SYSTEM)	42	
Terminals and Reference Value for Audio Unit (Premium System)	18	INSTALLATION - REAR DOOR TWEETER (PREMIUM SYSTEM)	42	
Terminals and Reference Value for Audio Amplifier (Premium System)	20	REMOVAL - SUBWOOFER (PREMIUM SYSTEM)	42	
Audio Unit Self-Diagnosis Function (Premium System)	23	INSTALLATION - SUBWOOFER (PREMIUM SYSTEM)	42	
STARTING THE SELF-DIAGNOSIS MODE	23	Removal and Installation of Audio Amplifier	43	
EXITING THE SELF-DIAGNOSIS MODE	23	REMOVAL	43	
DIAGNOSIS FUNCTION	23	INSTALLATION	43	
Trouble Diagnosis	24	Removal and Installation of Steering Wheel Audio Control Switches	43	
MALFUNCTION WITH RADIO AND CD (BASE SYSTEM)	24	REMOVAL	43	
MALFUNCTION WITH RADIO AND CD (PREMIUM SYSTEM)	24	INSTALLATION	43	
FOR RADIO ONLY	25	AUDIO ANTENNA	44	
FOR CD ONLY	25	Location of Antenna	44	
Noise Inspection	25	Fixed Antenna Rod Replacement	44	
TYPE OF NOISE AND POSSIBLE CAUSE	25	REMOVAL	44	
Power Supply Circuit Inspection	26	INSTALLATION	44	
Steering Switch Check (Premium System)	27			
Sound Is Not Heard From Front Door Speaker or				

PRECAUTIONS

PRECAUTIONS

PFP:00001

Precautions for Supplemental Restraint System (SRS) “AIR BAG” and “SEAT BELT PRE-TENSIONER”

EKS00DKD

The Supplemental Restraint System such as “AIR BAG” and “SEAT BELT PRE-TENSIONER”, used along with a front seat belt, helps to reduce the risk or severity of injury to the driver and front passenger for certain types of collision. This system includes seat belt switch inputs and dual stage front air bag modules. The SRS system uses the seat belt switches to determine the front air bag deployment, and may only deploy one front air bag, depending on the severity of a collision and whether the front occupants are belted or unbelted. Information necessary to service the system safely is included in the SRS and SB section of this Service Manual.

WARNING:

- To avoid rendering the SRS inoperative, which could increase the risk of personal injury or death in the event of a collision which would result in air bag inflation, all maintenance must be performed by an authorized NISSAN/INFINITI dealer.
- Improper maintenance, including incorrect removal and installation of the SRS, can lead to personal injury caused by unintentional activation of the system. For removal of Spiral Cable and Air Bag Module, see the SRS section.
- Do not use electrical test equipment on any circuit related to the SRS unless instructed to in this Service Manual. SRS wiring harnesses can be identified by yellow and/or orange harnesses or harness connectors.

Wiring Diagrams and Trouble Diagnosis

EKS00DKE

When you read wiring diagrams, refer to the following:

- [GI-16, "How to Read Wiring Diagrams"](#).
- [PG-4, "POWER SUPPLY ROUTING CIRCUIT"](#).

When you perform trouble diagnosis, refer to the following:

- [GI-12, "HOW TO FOLLOW TEST GROUPS IN TROUBLE DIAGNOSES"](#).
- [GI-28, "How to Perform Efficient Diagnosis for an Electrical Incident"](#).

PREPARATION

PREPARATION

PF0:00002

Commercial Service Tool

EKS00DKF

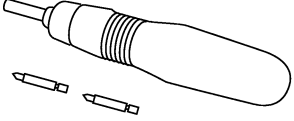
Tool name	Description
<p data-bbox="162 296 272 323">Power tool</p>  <p data-bbox="852 499 927 516">PBIC0191E</p>	<p data-bbox="1015 296 1268 323">Loosening bolts and nuts</p>

A
B
C
D
E
F
G
H
I
J
AV
L
M

AV

AUDIO

PF28111

AUDIO

Component Parts and Harness Connector Location

EKS00DKG

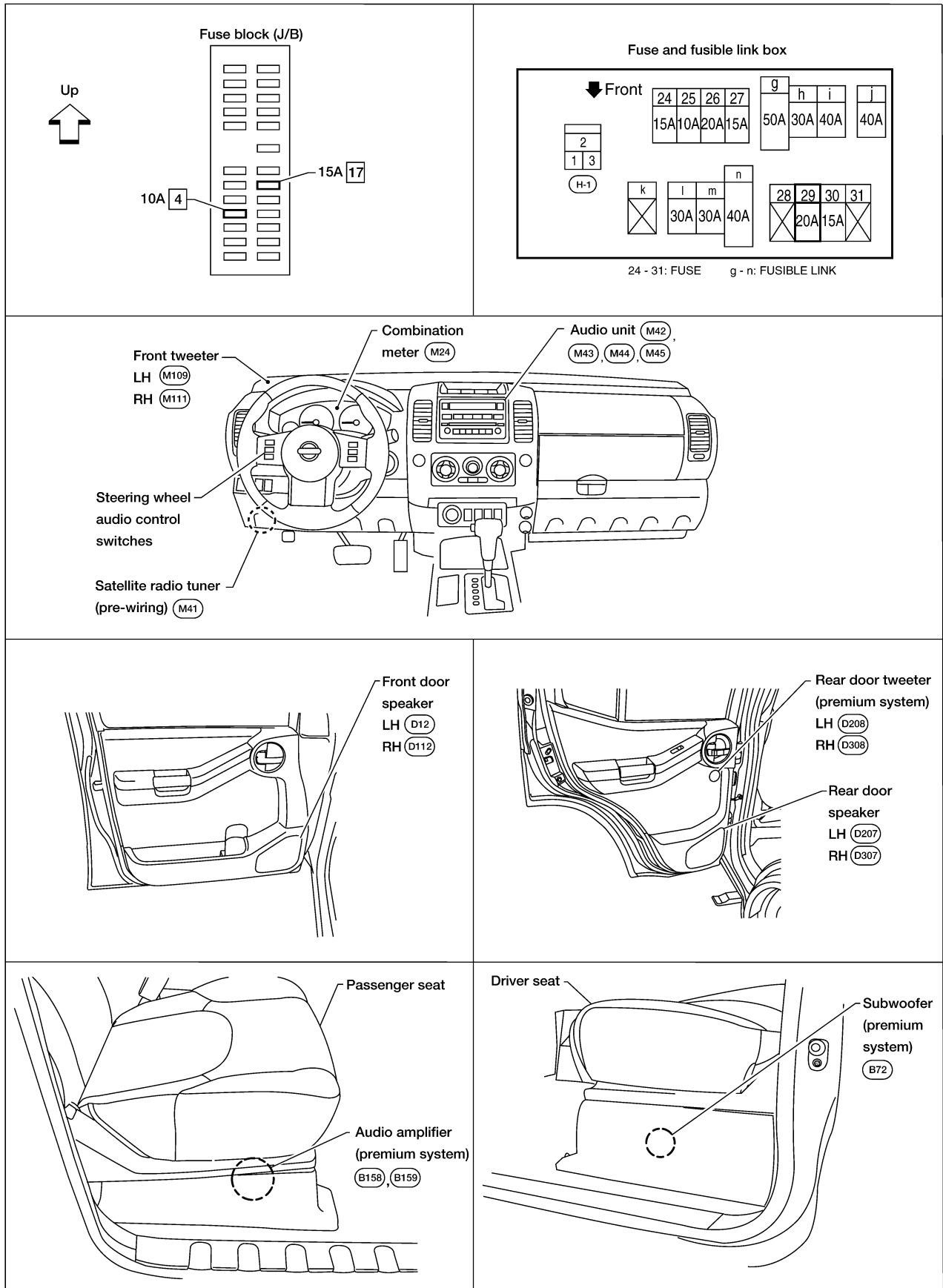

WKIA3721E

AUDIO

EKS00DKH

System Description BASE SYSTEM

Refer to Owner's Manual for audio system operating instructions.
Power is supplied at all times

- through 20A fuse (No. 29, located in the fuse and fusible link box)
- to audio unit terminal 6.

With the ignition switch in the ACC or ON position, power is supplied

- through 10A fuse [No. 4, located in the fuse block (J/B)]
- to audio unit terminal 10.

Ground is supplied through the case of the audio unit.
Then audio signals are supplied

- through audio unit terminals 1, 2, 3, 4, 13, 14, 15 and 16
- to terminals + and - of front door speaker LH and RH
- to terminals + and - of front tweeter LH and RH
- to terminals + and - of rear door speaker LH and RH.

PREMIUM SYSTEM

Refer to Owner's Manual for audio system operating instructions.
Power is supplied at all times

- through 15A fuse [No. 17, located in the fuse block (J/B)]
- to audio amplifier terminals 1 and 17
- through 20A fuse (No. 29, located in the fuse and fusible link box)
- to audio unit terminal 6.

With the ignition switch in the ACC or ON position, power is supplied

- through 10A fuse [No. 4, located in the fuse block (J/B)]
- to audio unit terminal 10.

Ground is supplied through the case of the audio unit.
Ground is also supplied

- to audio amplifier terminals 4 and 20
- through body grounds B117 and B132.

Then audio signals are supplied

- through audio unit terminals 1, 2, 3, 4, 13, 14, 15 and 16
- to audio amplifier terminals 5, 6, 7, 8, 21, 22, 23 and 24.

Audio signals are amplified by the audio amplifier.

The amplified audio signals are supplied

- through audio amplifier terminals 2, 3, 11, 12, 13, 14, 15, 16, 18, 19, 27, 28, 29, 30, 31 and 32
- to terminals + and - of front door speaker LH and RH
- to terminals + and - of front tweeter LH and RH
- to terminals + and - of rear door speaker LH and RH
- to terminals + and - of rear door tweeter LH and RH
- to terminals 1, 2, 3 and 4 of subwoofer.

When one of steering wheel audio control switches is pushed, the resistance in steering switch circuit changes depending on which button is pushed.

Satellite Radio Tuner (Pre-wiring)

The satellite radio tuner pre-wiring allows connection of a satellite radio tuner.
Power is supplied at all times

- through 15A fuse [No. 17, located in the fuse block (J/B)]
- to satellite radio tuner pre-wiring terminal 32.

With the ignition switch in the ACC or ON position, power is supplied

- through 10A fuse [No. 4, located in the fuse block (J/B)]
- to satellite radio tuner pre-wiring terminal 36.

A
B
C
D
E
F
G
H
I
J
L
M

AV

AUDIO

Ground is supplied through the case of the satellite radio tuner.

Then audio signals are supplied

- through satellite radio tuner pre-wiring terminals 21, 22, 23 and 24
- to audio unit terminals 41, 42, 43 and 44.

Speed Sensitive Volume System

Volume level of this system goes up and down automatically in proportion to the vehicle speed. The control level can be selected by the customer. Refer to Owner's Manual for operating instructions.

AUDIO

Schematic PREMIUM SYSTEM

EKS00DK1

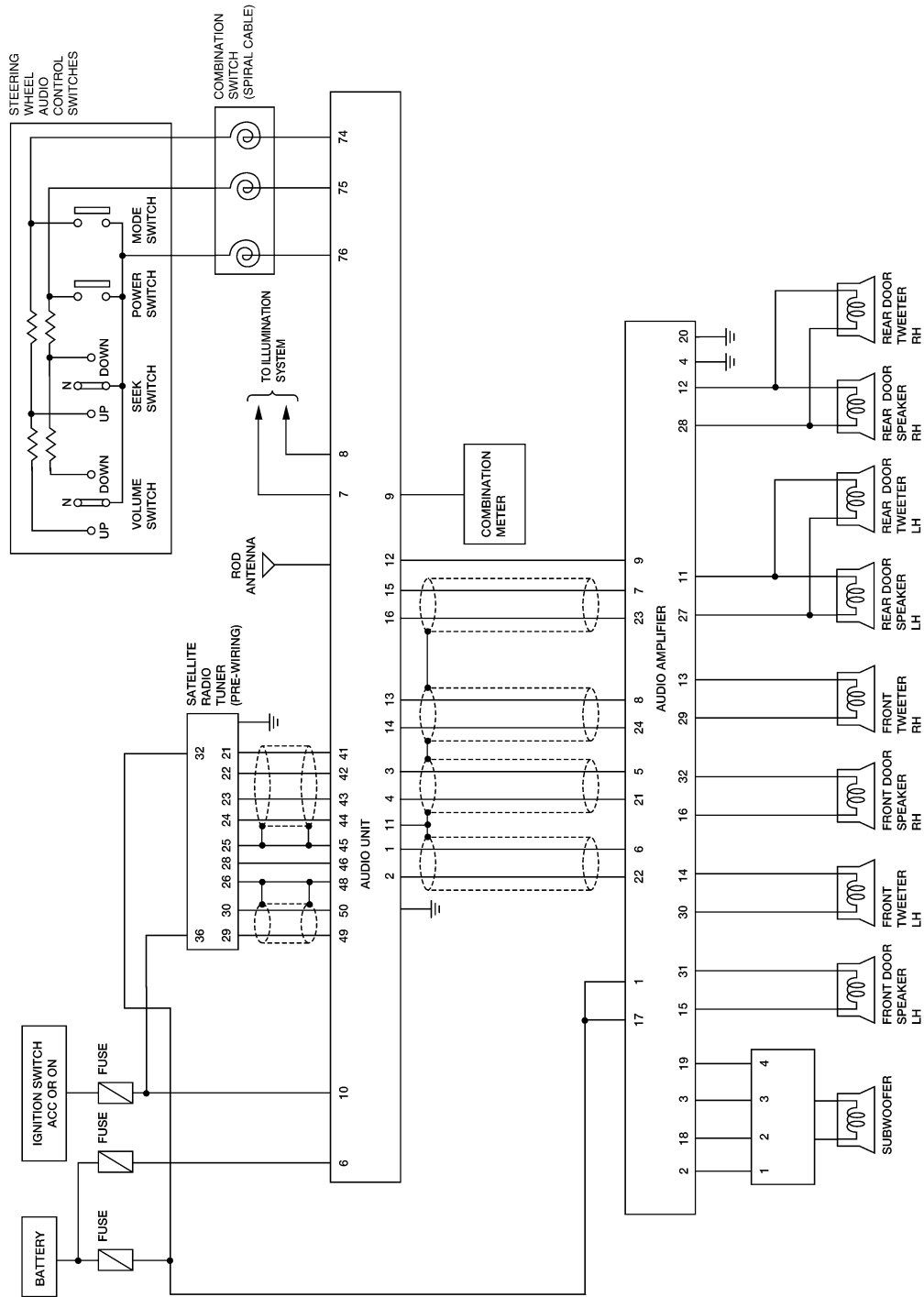

A
B
C
D
E
F
G
H
I
J
K
L
M

AV

AUDIO

Wiring Diagram — AUDIO — BASE SYSTEM

EKS00DKJ

AV-AUDIO-01

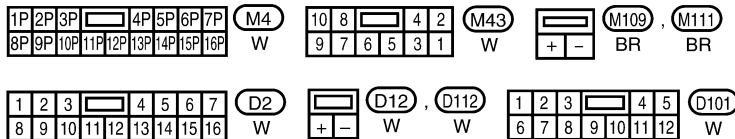
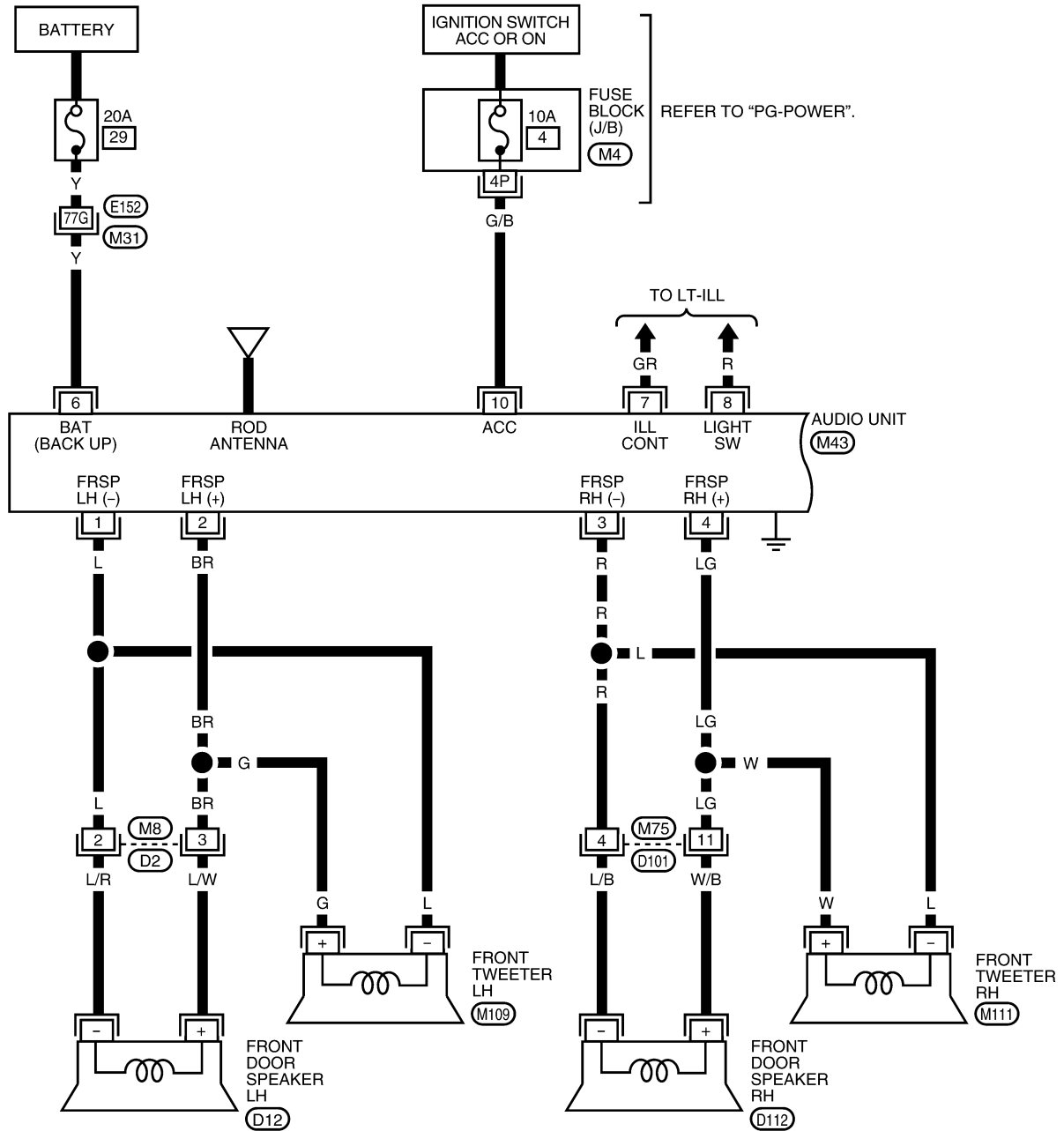

REFER TO THE FOLLOWING.
(M31) - SUPER MULTIPLE
JUNCTION (SMJ)

WKWA2577E

A
B
C
D
E
F
G
H
I
J
AV
L
M

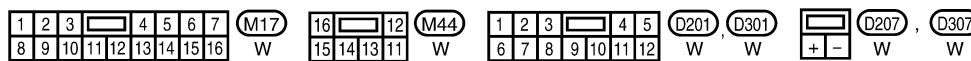
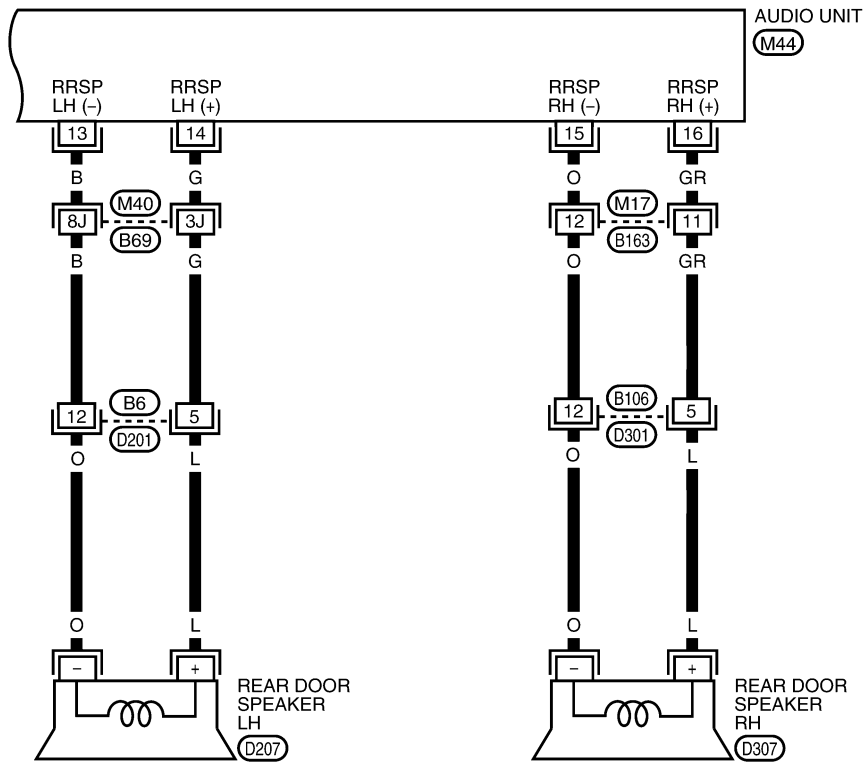

REFER TO THE FOLLOWING.
(M44) - SUPER MULTIPLE JUNCTION (SMJ)

AUDIO

PREMIUM SYSTEM

AV-AUDIO-03

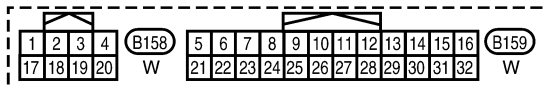
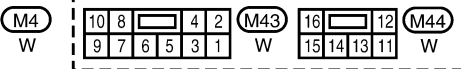
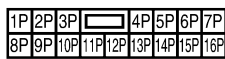
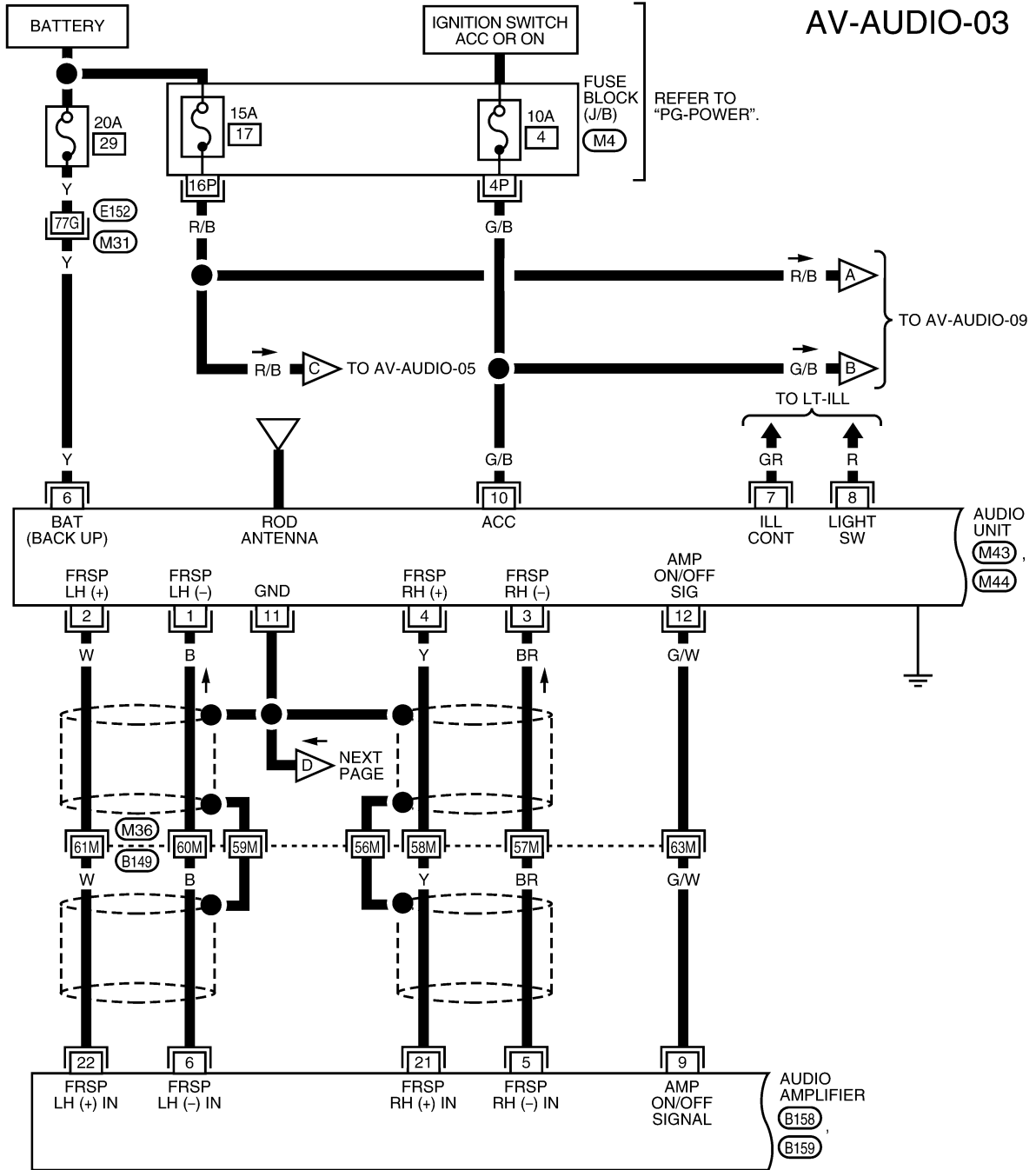

REFER TO THE FOLLOWING.
 (M31), (M36) - SUPER MULTIPLE
 JUNCTION (SMJ)

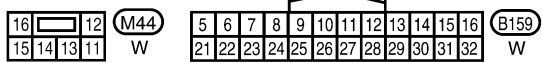
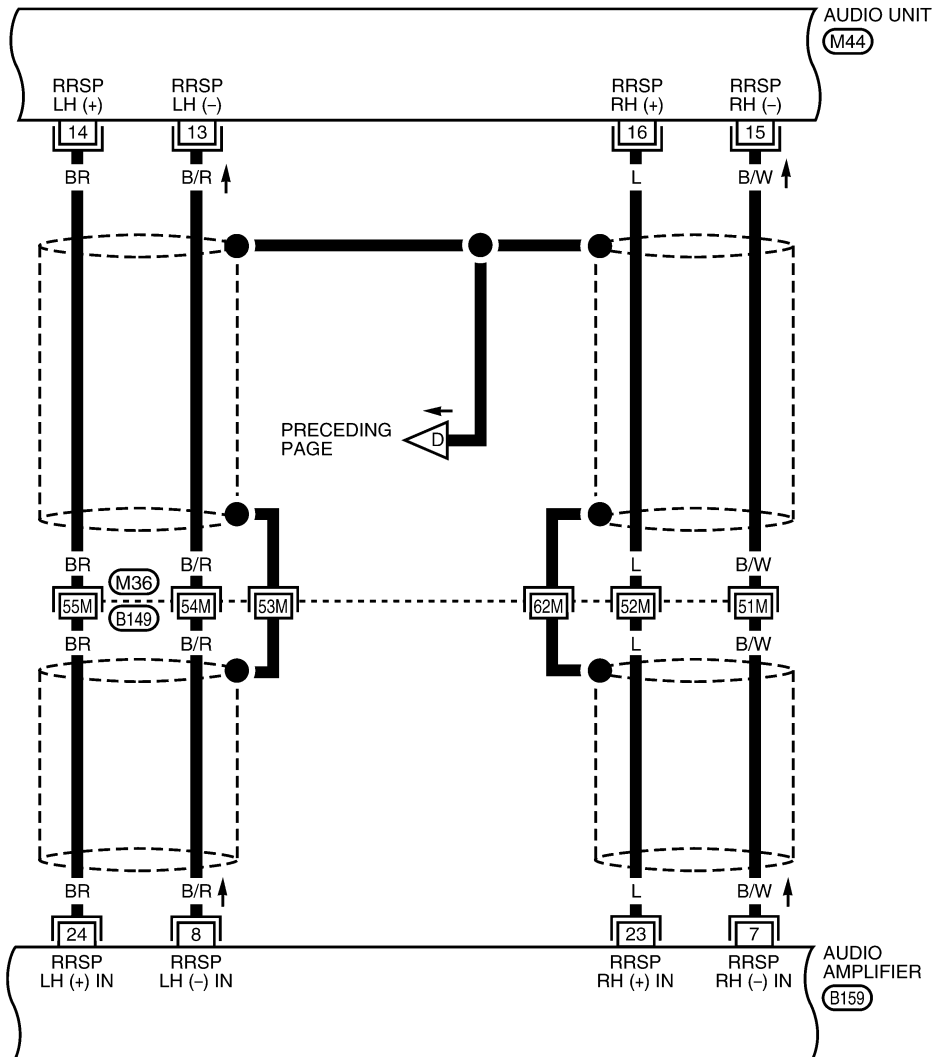

REFER TO THE FOLLOWING.
M36 - SUPER MULTIPLE JUNCTION (SMJ)

WKWA2581E

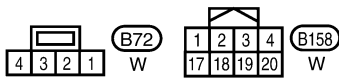
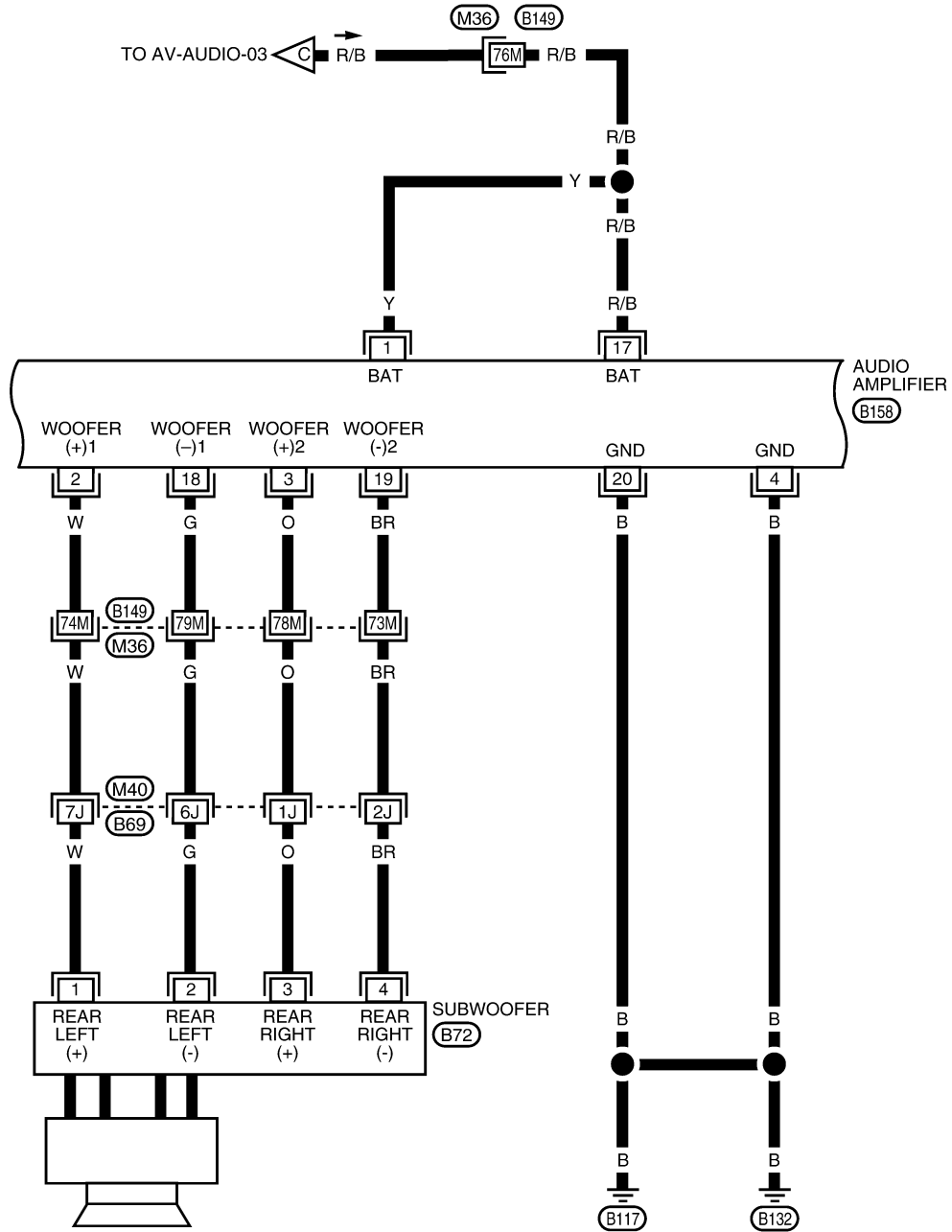

REFER TO THE FOLLOWING.
 (M36) (M40) - SUPER MULTIPLE JUNCTION (SMJ)

AUDIO

AV-AUDIO-06

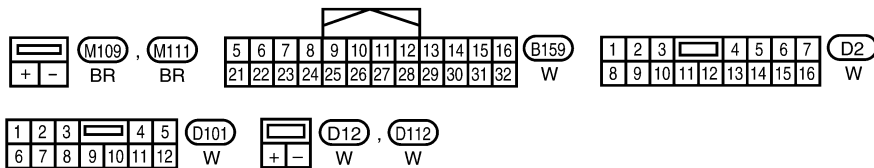
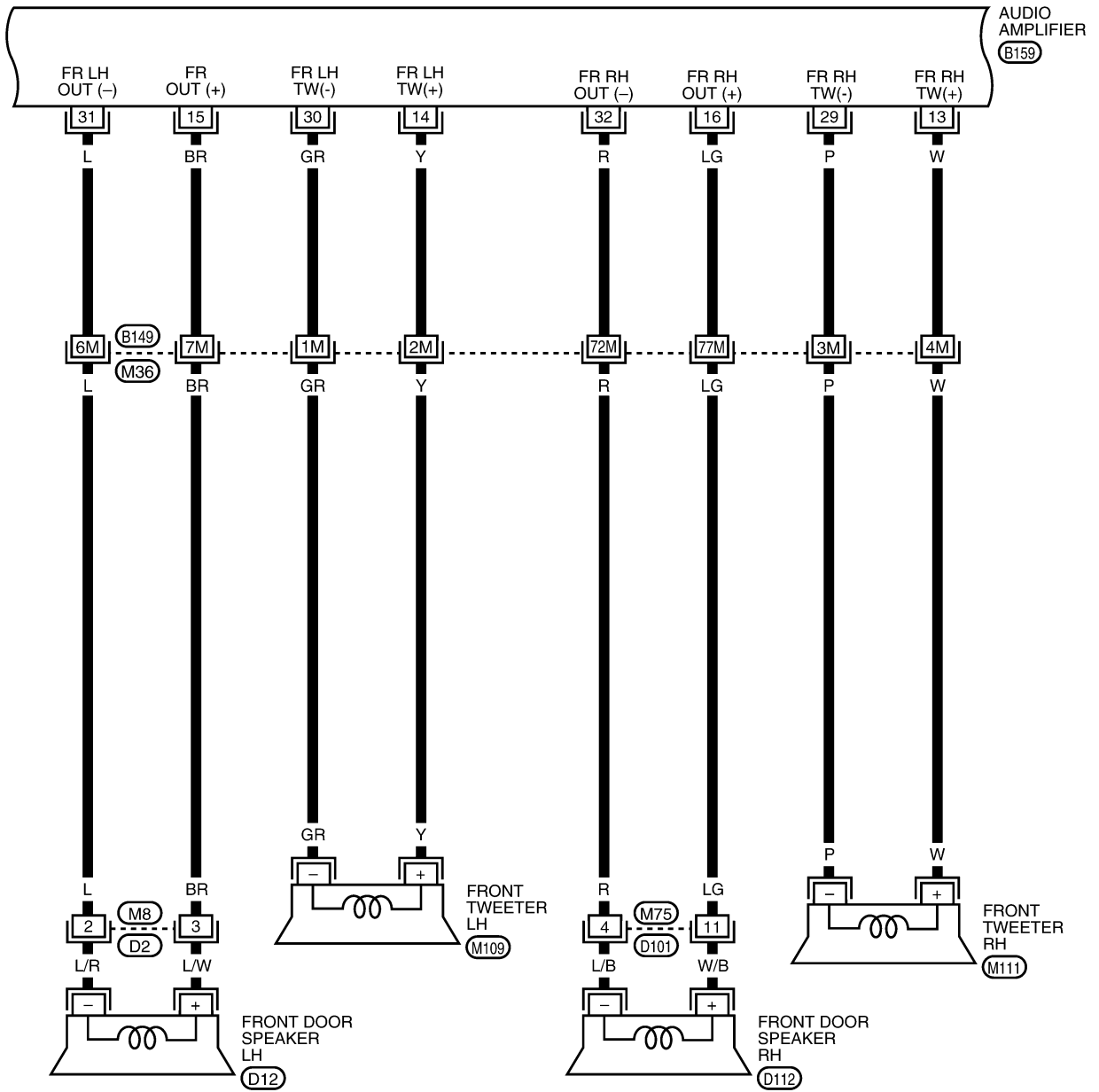

REFER TO THE FOLLOWING.
M36 - SUPER MULTIPLE JUNCTION (SMJ)

WKWA2583E

AUDIO

AV-AUDIO-07

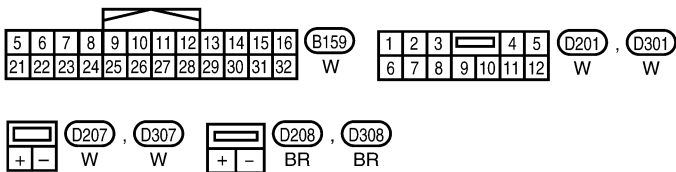
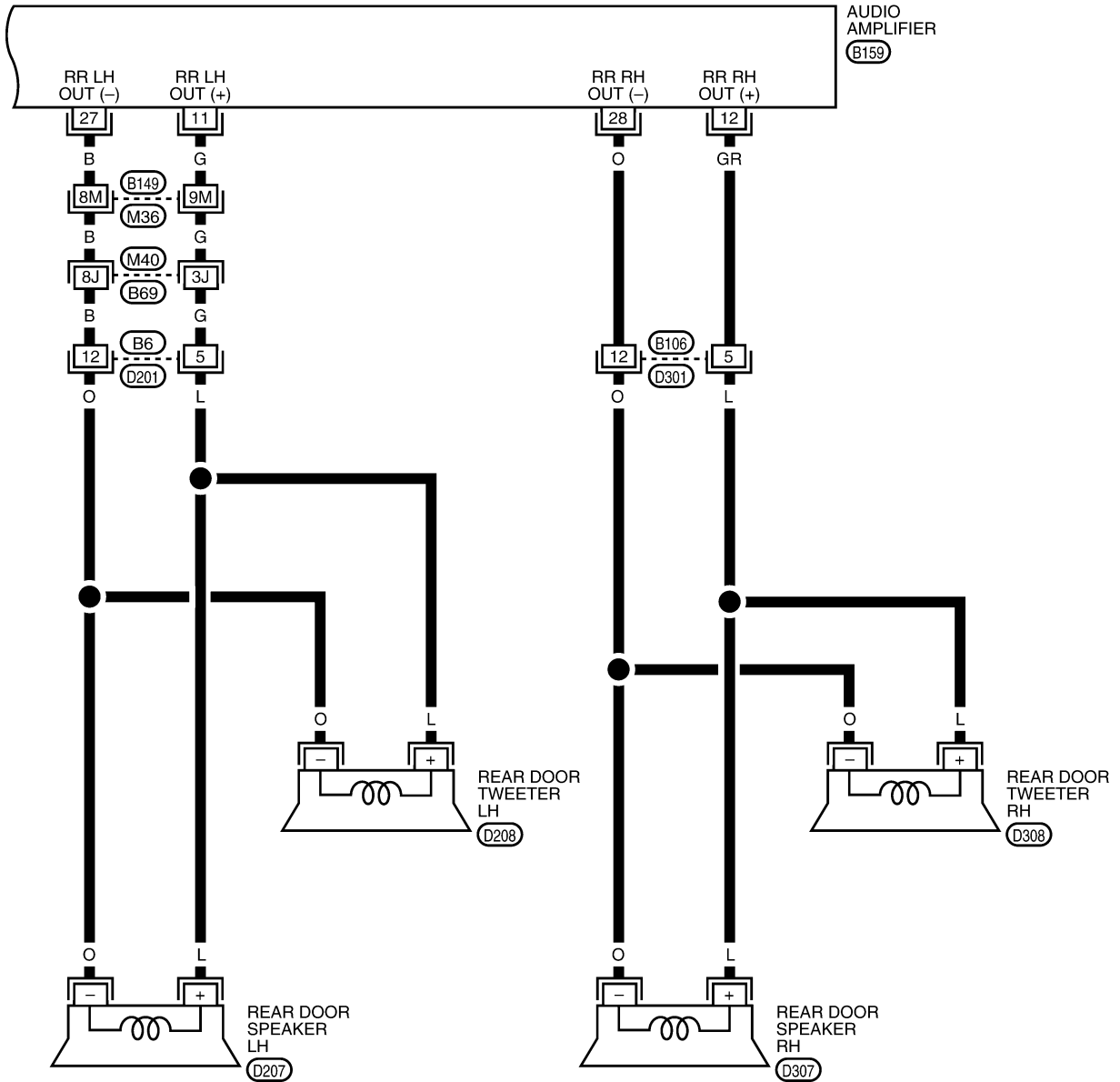

REFER TO THE FOLLOWING.
 (M36), (M40) - SUPER
 MULTIPLE JUNCTION (SMJ)

WKWA2584E

AUDIO

AV-AUDIO-08

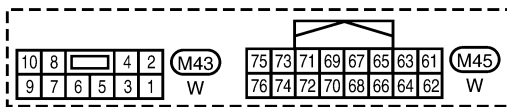
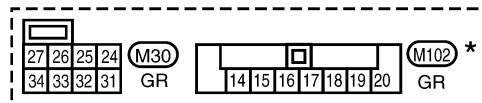
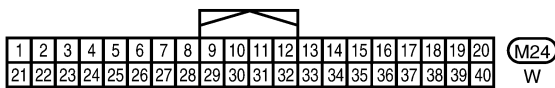
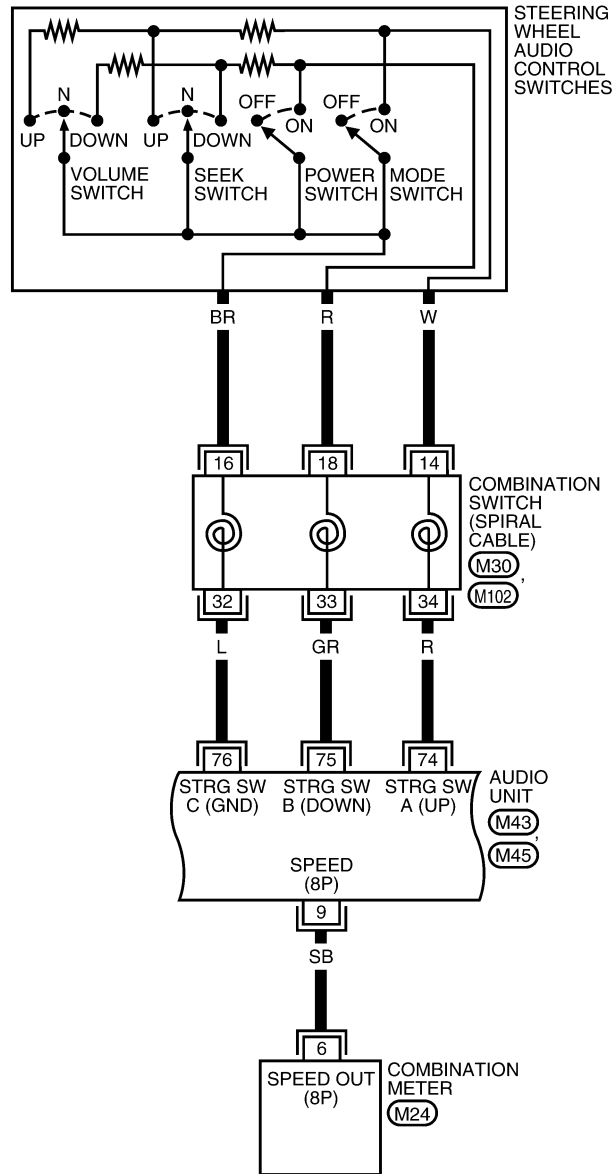

* : THIS CONNECTOR IS NOT SHOWN IN "HARNESS LAYOUT" OF PG SECTION.

WKWA2585E

AUDIO

AV-AUDIO-09

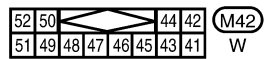
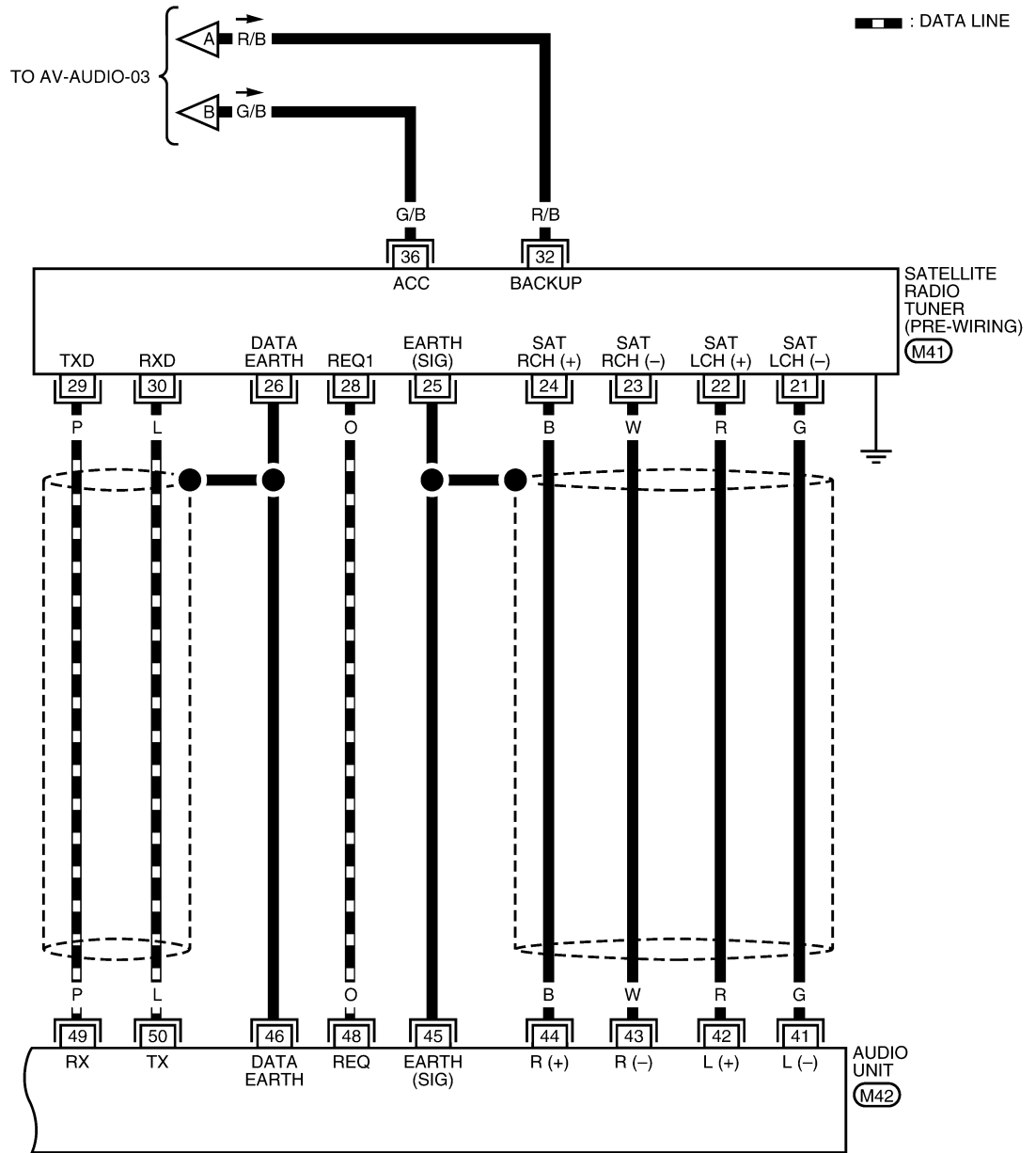

WKWA2586E

AUDIO

Terminals and Reference Value for Audio Unit (Base System)

EKS00DKK

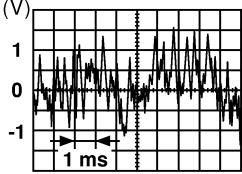
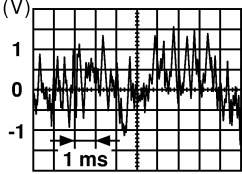
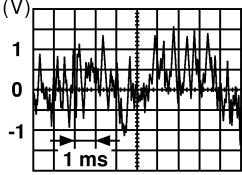
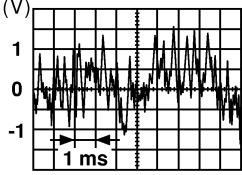
Terminal (Wire color)		Item	Signal input/ output	Condition		Reference value (Approx.)	Example of symptom
+	-			Ignition switch	Operation		
2 (BR)	1 (L)	Audio sound signal front LH	Output	ON	Receive audio signal	 <p style="text-align: right; font-size: small;">SKIA0177E</p>	No sound from front door speaker LH or front tweeter LH.
4 (LG)	3 (R)	Audio sound signal front RH	Output	ON	Receive audio signal	 <p style="text-align: right; font-size: small;">SKIA0177E</p>	No sound from front door speaker RH or front tweeter RH.
6 (Y)	Ground	Battery power	Input	-	-	Battery voltage	System does not work properly.
7 (GR)	Ground	Illumination control sig- nal	Input	ON	Illumination control switch is operated by lighting switch in 1st position.	Changes between 0 and 12V	Audio unit illumina- tion cannot be con- trolled.
8 (R)	Ground	Illumination signal	Input	OFF	Lighting switch is in 1st posi- tion.	Battery voltage	Audio unit illumina- tion does not come on when lighting switch is in 1st posi- tion.
					Lighting switch is OFF.	3V or less	
10 (G/B)	Ground	ACC power	Input	ACC	Ignition switch ACC or ON	Battery voltage	System does not work properly.
14 (G)	13 (B)	Audio sound signal rear LH	Output	ON	Receive audio signal	 <p style="text-align: right; font-size: small;">SKIA0177E</p>	No sound from rear door speaker LH.
16 (GR)	15 (O)	Audio sound signal rear RH	Output	ON	Receive audio signal	 <p style="text-align: right; font-size: small;">SKIA0177E</p>	No sound from rear door speaker RH.

A
B
C
D
E
F
G
H
I
J
AV
L
M

AUDIO

Terminals and Reference Value for Audio Unit (Premium System)

EKS00DKL

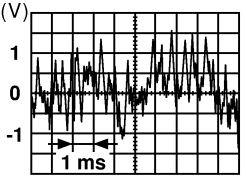
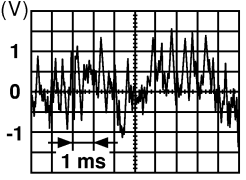
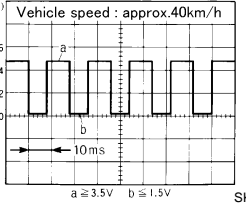
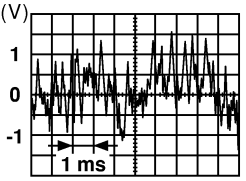
Terminal (Wire color)		Item	Signal input/ output	Condition		Reference value (Approx.)	Example of symptom
+	-			Ignition switch	Operation		
2 (W)	1 (B)	Audio sound signal front LH	Output	ON	Receive audio signal	 SKIA0177E	No sound from front door speaker LH or front tweeter LH.
4 (Y)	3 (BR)	Audio sound signal front RH	Output	ON	Receive audio signal	 SKIA0177E	No sound from front door speaker RH or front tweeter RH.
6 (Y)	Ground	Battery power	Input	-	-	Battery voltage	System does not work properly.
7 (GR)	Ground	Illumination control signal	Input	ON	Illumination control switch is operated by light- ing switch in 1st position.	Changes between 0 and 12V	Audio unit illumina- tion cannot be control- led.
8 (R)	Ground	Illumination signal	Input	OFF	Lighting switch is in 1st position. Lighting switch is OFF.	Battery voltage 3V or less	Audio unit illumina- tion does not come on when lighting switch is in 1st posi- tion.
9 (SB)	Ground	Vehicle speed signal	Input	ON	When vehicle speed is approx. 40 km/h (25 MPH)	 SKIA0168E	Speed sensitive vol- ume inoperative.
10 (G/B)	Ground	ACC power	Input	ACC	-	Battery voltage	System does not work properly.
11	-	Shield ground	-	-	-	-	-
12 (G/W)	Ground	Amp. ON/ OFF signal	Output	ON	-	More than 6.5V	Audio amplifier does not work properly.
14 (BR)	13 (B/R)	Audio sound signal rear LH	Output	ON	Receive audio signal	 SKIA0177E	No sound from rear door speaker LH or rear door tweeter LH.

AUDIO

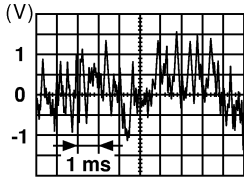
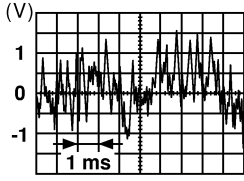
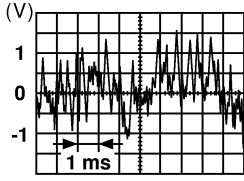
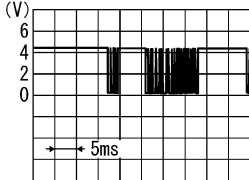
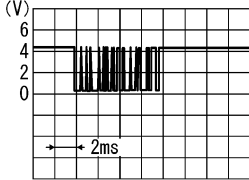
Terminal (Wire color)		Item	Signal input/ output	Condition		Reference value (Approx.)	Example of symptom
+	-			Ignition switch	Operation		
16 (L)	15 (B/W)	Audio sound signal rear RH	Output	ON	Receive audio signal	 SKIA0177E	No sound from rear door speaker RH or rear door tweeter RH.
42 (R)	41 (G)	Audio left channel sound sig- nal from sat- ellite radio tuner	Input	ON	Receive audio signal	 SKIA0177E	No sound from satel- lite radio tuner left channel.
44 (B)	43 (W)	Audio right channel sound sig- nal from sat- ellite radio tuner	Input	ON	Receive audio signal	 SKIA0177E	No sound from satel- lite radio tuner right channel.
45	-	Shield ground (audio sig- nal)	-	-	-	-	-
46	-	Shield ground (data)	-	-	-	-	-
48 (O)	Ground	Satellite radio tuner request to audio unit	Input	ON	Turn audio unit ON	5V	Satellite radio tuner does not operate properly.
49 (P)	Ground	Audio RX	Input	ON	Operate audio volume	 SKIA4403E	Satellite radio tuner audio information does not display properly.
50 (L)	Ground	Audio TX	Output	ON	Operate audio volume	 SKIA4402E	Satellite radio tuner audio information does not display properly.

A
B
C
D
E
F
G
H
I
J
AV

L
M

AUDIO

Terminal (Wire color)		Item	Signal input/ output	Condition		Reference value (Approx.)	Example of symptom
+	-			Ignition switch	Operation		
74 (R)	Ground	Remote control A	Input	ON	Press MODE switch	0V	Steering wheel audio controls do not func- tion.
					Press SEEK UP switch	0.75V	
					Press VOL UP switch	2V	
					Except for above	5V	
75 (GR)	Ground	Remote control B	Input	ON	Press POWER switch	0V	Steering wheel audio controls do not func- tion.
					Press SEEK DOWN switch	0.75V	
					Press VOL DOWN switch	2V	
					Except for above	5V	
76 (L)	-	Remote control ground	-	-	-	-	Steering wheel audio controls do not func- tion.

Terminals and Reference Value for Audio Amplifier (Premium System)

EKS00E17

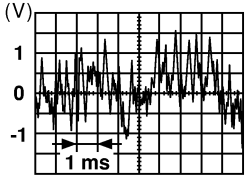
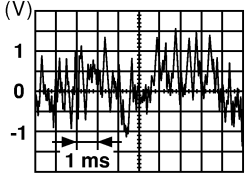
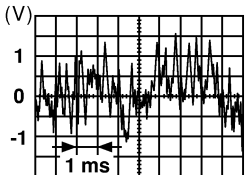
Terminal (wire color)		Item	Signal input/ output	Condition		Reference value (Approx.)	Example of symptom
+	-			Ignition switch	Operation		
1 (Y)	Ground	Battery	Input	-	-	Battery voltage	System does not work properly.
2 (W)	18 (G)	Subwoofer	Output	ON	Receive audio signal	 SKIA0177E	No sound from subwoofer.
3 (O)	19 (BR)	Subwoofer	Output	ON	Receive audio signal	 SKIA0177E	No sound from subwoofer.
4 (B)	Ground	Ground	-	ON	-	-	-
9 (G/W)	Ground	Amp. ON sig- nal	Input	ON	-	More than 6.5V	System does not work properly.
11 (G)	27 (B)	Rear door speaker LH and rear door tweeter LH	Output	ON	Receive audio signal	 SKIA0177E	No sound from rear door speaker LH or rear door tweeter LH.

AUDIO

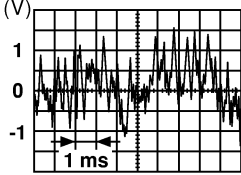
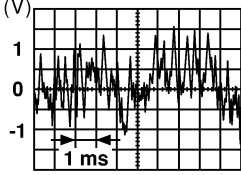
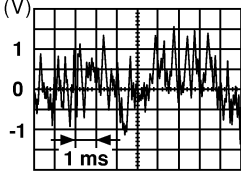
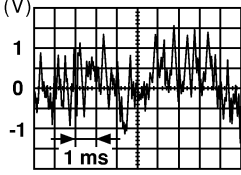
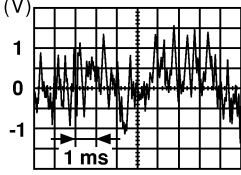
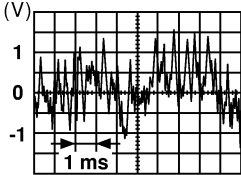
Terminal (wire color)		Item	Signal input/ output	Condition		Reference value (Approx.)	Example of symptom
+	-			Ignition switch	Operation		
12 (GR)	28 (O)	Rear door speaker RH and rear door tweeter RH	Output	ON	Receive audio signal	 SKIA0177E	No sound from rear door speaker RH or rear door tweeter RH.
13 (W)	29 (P)	Front tweeter RH	Output	ON	Receive audio signal	 SKIA0177E	No sound from front tweeter RH.
14 (Y)	30 (GR)	Front tweeter LH	Output	ON	Receive audio signal	 SKIA0177E	No sound from front tweeter LH.
15 (BR)	31 (L)	Front door speaker LH	Output	ON	Receive audio signal	 SKIA0177E	No sound from front door speaker LH.
16 (LG)	32 (R)	Front door speaker RH	Output	ON	Receive audio signal	 SKIA0177E	No sound from front door speaker RH.
17 (R/B)	Ground	Battery	Input	-	-	Battery voltage	System does not work properly.
20 (B)	Ground	Ground	-	ON	-	-	-
21 (Y)	5 (BR)	Audio sound signal front RH	Input	ON	Receive audio signal	 SKIA0177E	No sound from front door speaker RH or front tweeter RH.

A
B
C
D
E
F
G
H
I
J
L
M

AV

AUDIO

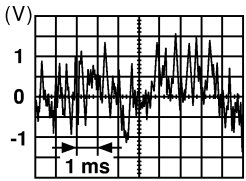
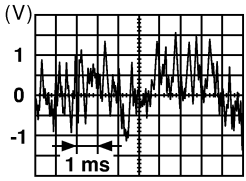
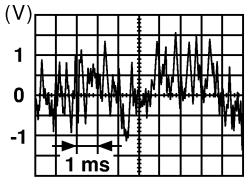
Terminal (wire color)		Item	Signal input/ output	Condition		Reference value (Approx.)	Example of symptom
+	-			Ignition switch	Operation		
22 (W)	6 (B)	Audio sound signal front LH	Input	ON	Receive audio signal	 <p style="text-align: right; font-size: small;">SKIA0177E</p>	No sound from front door speaker LH or front tweeter LH.
23 (L)	7 (B/W)	Audio sound signal rear RH	Input	ON	Receive audio signal	 <p style="text-align: right; font-size: small;">SKIA0177E</p>	No sound from rear door speaker RH or rear door tweeter RH.
24 (BR)	8 (B/R)	Audio sound signal rear LH	Input	ON	Receive audio signal	 <p style="text-align: right; font-size: small;">SKIA0177E</p>	No sound from rear door speaker LH or rear door tweeter LH.

AUDIO

EKS00E18

Audio Unit Self-Diagnosis Function (Premium System)

It can check ON/OFF operation of each switch in the audio unit and diagnose the input signals from the steering switch.

STARTING THE SELF-DIAGNOSIS MODE

1. Turn ignition switch from OFF to ACC.
2. Press and hold the "CLOCK" switch and turn the volume control dial clockwise or counterclockwise for 30 clicks or more.

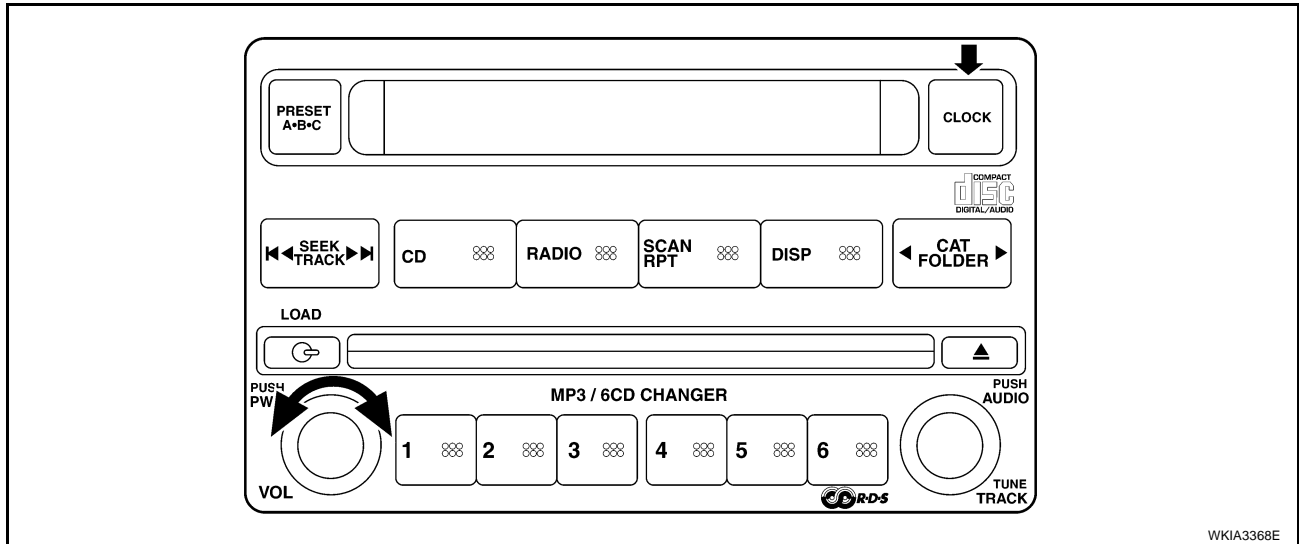

Then the self-diagnosis operates. A single beep indicates self-diagnosis mode is active.

3. Initially, all display segments will be illuminated.
4. Press each switch. When each switch is pressed, its name and communication code will be displayed.

NOTE:

CD player LOAD and EJECT buttons are not included in this test and will not change the display when pressed.

EXITING THE SELF-DIAGNOSIS MODE

Turn ignition switch OFF. Then the self-diagnosis ends.

DIAGNOSIS FUNCTION

- It can check for continuity of the switches by sounding a beep when each audio unit switch and steering switch is pressed.
- It can check for continuity of harness between audio unit and steering switch.

A
B
C
D
E
F
G
H
I
J
AV
L
M

AUDIO

EKS00E19

Trouble Diagnosis

The majority of the audio troubles are the result of outside causes (bad CD, electromagnetic interference, etc.). Check the inspection items below to diagnose the malfunction.

MALFUNCTION WITH RADIO AND CD (BASE SYSTEM)

Symptom	Possible cause
Inoperative	<ul style="list-style-type: none">● Audio unit power circuit check. Refer to AV-26, "Power Supply Circuit Inspection" . If above check is OK, replace audio unit.
All speakers do not sound	<ul style="list-style-type: none">● Audio unit
One or several speakers do not sound	<ul style="list-style-type: none">● Front door speaker check. Refer to AV-29, "Sound Is Not Heard From Front Door Speaker or Front Tweeter (Base System)" .● Rear door speaker check. Refer to AV-31, "Sound Is Not Heard From Rear Door Speaker (Base System)" .
Poor sound	<ul style="list-style-type: none">● Audio unit● Speaker
Noisy	<ul style="list-style-type: none">● Audio unit● Electrical equipment (generator, bonding wire, etc.)

MALFUNCTION WITH RADIO AND CD (PREMIUM SYSTEM)

Symptom	Possible cause
Inoperative	<ul style="list-style-type: none">● Audio unit power circuit check. Refer to AV-26, "Power Supply Circuit Inspection" . If above check is OK, replace audio unit.
Steering switch does not operate	<ul style="list-style-type: none">● Steering switch check. Refer to AV-27, "Steering Switch Check (Premium System)" . If above check is OK, replace audio unit.
All speakers do not sound	<ul style="list-style-type: none">● Audio unit● Audio amplifier power supply and ground circuit check. Refer to AV-26, "Power Supply Circuit Inspection" .● Audio amplifier ON signal● Audio amplifier
One or several speakers do not sound	<ul style="list-style-type: none">● Front door speaker check. Refer to AV-33, "Sound Is Not Heard From Front Door Speaker or Front Tweeter (Premium System)" .● Rear door speaker check. Refer to AV-36, "Sound Is Not Heard From Rear Door Speaker or Rear Door Tweeter (Premium System)" .● Subwoofer check. Refer to AV-40, "Sound Is Not Heard From Subwoofer (Premium System)" .
Poor sound	<ul style="list-style-type: none">● Audio unit● Audio amplifier● Speaker
Noisy	<ul style="list-style-type: none">● Audio unit● Audio amplifier● Electrical equipment (generator, bonding wire, etc.)

AUDIO

FOR RADIO ONLY

Symptom	Possible cause
No sound	<ul style="list-style-type: none"> ● Audio unit ● Antenna feeder, wiring or connections
Noisy	<ul style="list-style-type: none"> ● Audio unit ● Audio unit case ground ● Antenna feeder, wiring or connections ● Noise prevention parts ● Electrical equipment ● Wire harness of each piece of electrical equipment
All radio stations stored in memory are deleted	<ul style="list-style-type: none"> ● Audio unit power circuit. Refer to AV-26, "Power Supply Circuit Inspection". ● Audio unit

NOTE:

The following noise results from variations in field strength, such as fading noise and multi-path noise, or external noise from trains and other sources. It is not a malfunction.

- Fading noise: This noise occurs because of variations in the field strength in a narrow range due to mountains or buildings blocking the signal.
- Multi-path noise: This noise results from the waves sent directly from the broadcast station arriving at the antenna at a different time from the waves which reflect off mountains or buildings.

FOR CD ONLY

Symptom	Possible cause
CD cannot be inserted.	<ul style="list-style-type: none"> ● CD ● Audio unit
CD cannot be ejected.	
The CD cannot be played.	
The sound skips, stops suddenly, or is distorted.	

Noise Inspection

EKS00E1A

The vehicle itself can be a source of noise if noise prevention parts or electrical equipment is malfunctioning. Check if noise is caused and/or changed by engine speed, ignition switch turned to each position, and operation of each piece of electrical equipment, and determine the cause.

NOTE:

The source of the noise can be found easily by listening to the noise while removing the fuses of electrical components, one by one.

TYPE OF NOISE AND POSSIBLE CAUSE

Occurrence condition	Possible cause	
Occurs only when engine is ON.	A continuous growling noise occurs. The speed of the noise varies with changes in the engine speed.	● Ignition components
	A whistling noise occurs while the engine speed is high. A booming noise occurs while the engine is running and the lighting switch is ON.	● Generator
The occurrence of the noise is linked with the operation of the fuel pump.	● Fuel pump condenser	
Noise only occurs when various electrical components are operating.	A cracking or snapping sound occurs with the operation of various switches.	● Relay malfunction, audio unit malfunction
	The noise occurs when various motors are operating.	<ul style="list-style-type: none"> ● Motor case ground ● Motor

AUDIO

Occurrence condition	Possible cause
The noise occurs constantly, not just under certain conditions.	<ul style="list-style-type: none"> ● Rear defogger coil malfunction ● Open circuit in printed heater ● Poor ground of antenna feeder line
A cracking or snapping sound occurs while the vehicle is being driven, especially when it is vibrating excessively.	<ul style="list-style-type: none"> ● Ground wire of body parts ● Ground due to improper part installation ● Wiring connections or a short circuit

Power Supply Circuit Inspection

EKS00E1B

1. CHECK FUSES

Check that the following fuses are not blown.

Unit	Terminals	Signal name	Fuse No.
Audio unit	6	Battery power	29
	10	Ignition switch ACC or ON	4
Audio amplifier (premium system)	1	Battery power	17
	17		

OK or NG

OK >> GO TO 2.

NG >> If fuse is blown, be sure to eliminate cause of problem before installing new fuse. Refer to [PG-4](#), "[POWER SUPPLY ROUTING CIRCUIT](#)".

2. POWER SUPPLY CIRCUIT CHECK

1. Disconnect audio unit connector M43 and audio amplifier connector B158 (premium system).
2. Check voltage between the audio unit and ground.

Unit	Terminal No.			OFF	ACC	ON
	(+)		(-)			
	Connector	Terminal				
Audio unit	M43	6	Ground	Battery voltage	Battery voltage	Battery voltage
		10	Ground	0V	Battery voltage	Battery voltage

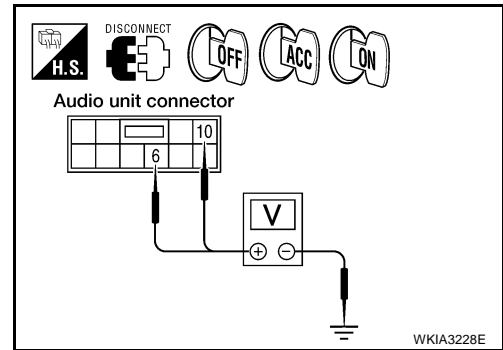

3. Check voltage between audio amplifier (premium system) and ground.

Unit	Terminal No.			OFF	ACC	ON
	(+)		(-)			
	Connector	Terminal				
Audio amplifier	B158	1	Ground	Battery voltage	Battery voltage	Battery voltage
		17				

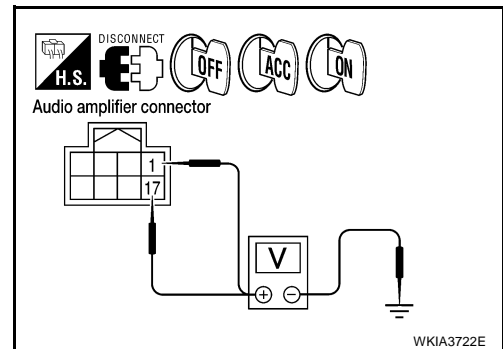

OK or NG

OK >> GO TO 3.

- NG >> ● Check connector housings for disconnected or loose terminals.
 ● Repair harness or connector.

AUDIO

3. GROUND CIRCUIT CHECK

1. Turn ignition switch OFF.
2. Check continuity between audio amplifier (premium system) harness connector B158 terminal 4 and terminal 20 and ground.

Continuity should exist.

OK or NG

- OK >> Inspection End.
 NG >> ● Check connector housings for disconnected or loose terminals.
 ● Repair harness or connector.

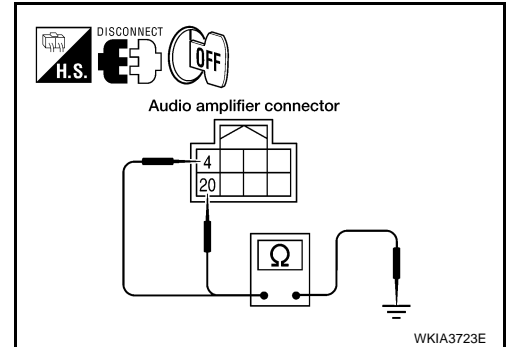

EKS00E1Q

Steering Switch Check (Premium System)

1. SELF-DIAGNOSIS FUNCTION CHECK

1. Start audio unit self-diagnosis function. Refer to [AV-23, "Audio Unit Self-Diagnosis Function \(Premium System\)"](#).
2. Operate steering switch.

Does steering switch operate normally?

- YES >> Inspection End.
 NO >> GO TO 2.

2. CHECK HARNESS

1. Turn ignition switch OFF.
2. Disconnect audio unit connector M45 and spiral cable connector M30.
3. Check continuity between spiral cable harness connector terminal and audio unit harness connector terminal.

Terminals				Continuity
Spiral cable		Audio unit		
Connector	Terminal	Connector	Terminal	
M30	32	M45	76	Yes
	33		75	
	34		74	

4. Check continuity between audio unit and ground.

Terminals			Continuity
Audio unit		—	
Connector	Terminal		
M45	74	Ground	No
	75		
	76		

OK or NG

- OK >> GO TO 3.
 NG >> Repair harness.

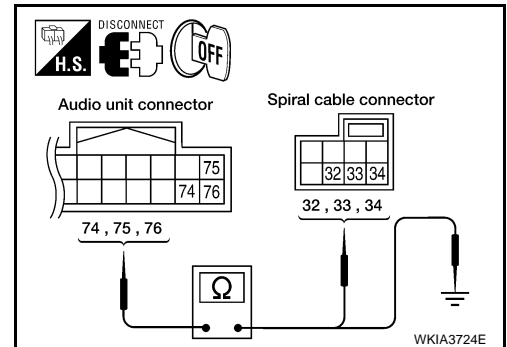

A
B
C
D
E
F
G
H
I
J
L
M

AV

AUDIO

3. SPIRAL CABLE CHECK

1. Disconnect spiral cable connectors M30 and M102.
2. Check continuity between spiral cable harness connector terminals.

Terminals				Continuity
Spiral cable				
Connector	Terminal	Connector	Terminal	
M30	32	M102	16	Yes
	33		18	
	34		14	

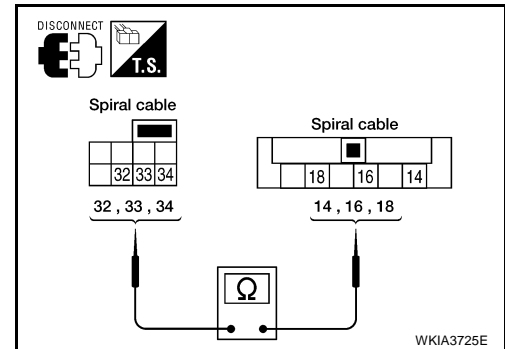

OK or NG

OK >> GO TO 4.

NG >> Replace spiral cable. Refer to [SRS-44, "SPIRAL CABLE"](#) .

4. CHECK STEERING SWITCH RESISTANCE

Check resistance between steering switch terminals.

Terminal	Signal name	Condition	Resistance (Ω) (Approx.)
18	16	Seek (down)	Depress (station) down switch. 165
		Power	Depress power switch. 0
		Volume (down)	Depress volume down switch. 652
14	16	Seek (up)	Depress (station) up switch. 165
		Mode	Depress mode switch. 0
		Volume (up)	Depress volume up switch. 652

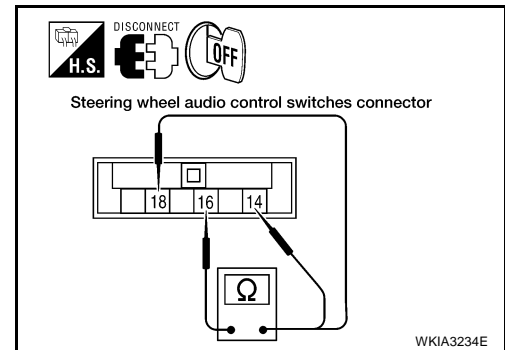

OK or NG

OK >> Inspection End.

NG >> Replace steering switch. Refer to [AV-43, "Removal and Installation of Steering Wheel Audio Control Switches"](#) .

AUDIO

Sound Is Not Heard From Front Door Speaker or Front Tweeter (Base System)

EKS00E1R

1. HARNESS CHECK

1. Turn ignition switch OFF.
2. Disconnect audio unit connector M43 and suspect speaker or tweeter connector.
3. Check continuity between audio unit harness connector M43 terminal and suspect speaker or tweeter harness connector terminal.

Terminals				Continuity
Audio unit		Speaker or tweeter		
Connector	Terminal	Connector	Terminal	
M43	2	D12	+	Yes
	1		-	
	4	D112	+	
	3		-	
	2	M109	+	
	1		-	
	4	M111	+	
	3		-	

4. Check continuity between audio unit harness connector M43 terminal and ground.

Terminals			Continuity
Connector	Terminal	—	
M43	2	Ground	No
	1		
	4		
	3		

OK or NG

- OK >> GO TO 2.
 NG >> ● Check connector housings for disconnected or loose terminals.
 ● Repair harness or connector.

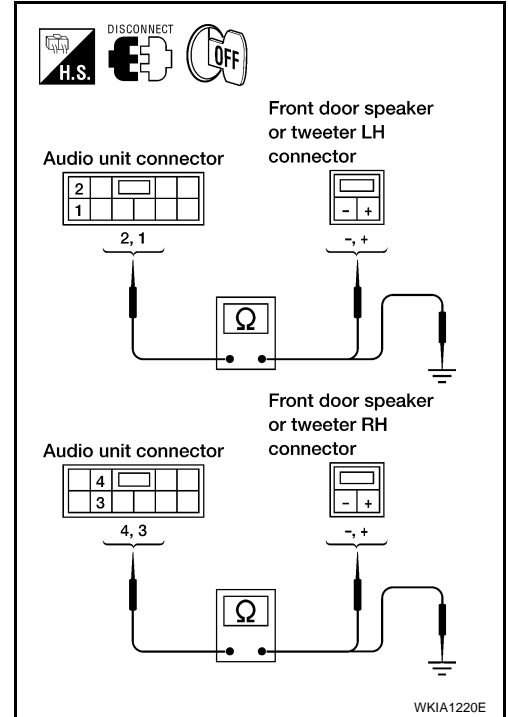

AUDIO

2. FRONT SPEAKER SIGNAL CHECK

1. Connect audio unit connector and front speaker or tweeter connector.
2. Turn ignition switch to ACC.
3. Push "POWER" switch.
4. Check the signal between audio unit harness connector terminal and ground with CONSULT-II or oscilloscope.

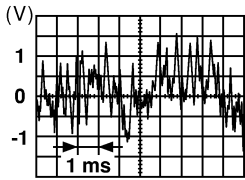
Terminals				Condi- tion	Reference signal
(+)		(-)			
Con- nec- tor	Termi- nal	Con- nec- tor	Termi- nal		
M43	2	M43	1	Receive audio signal	
	4		3		

SKIA0177E

OK or NG

- OK >> Replace speaker. Refer to [AV-41, "Removal and Installation of Speaker"](#) .
- NG >> Replace audio unit. Refer to [AV-41, "Removal and Installation for Audio Unit"](#) .

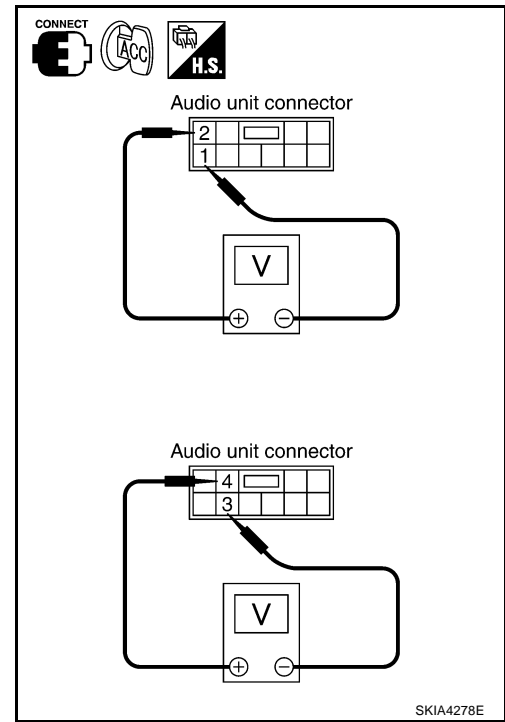

AUDIO

Sound Is Not Heard From Rear Door Speaker (Base System)

EKS00E1S

1. HARNESS CHECK

1. Turn ignition switch OFF.
2. Disconnect audio unit connector M44 and suspect speaker connector.
3. Check continuity between audio unit harness connector M44 terminal and suspect speaker harness connector terminal.

Terminals				Continuity
Audio unit		Speaker or tweeter		
Connector	Terminal	Connector	Terminal	
M44	13	D207	-	Yes
	14		+	
	15	D307	-	
	16		+	

4. Check continuity between audio unit harness connector M44 terminal and ground.

Terminals			Continuity
Audio unit		—	
Connector	Terminal		
M44	13	Ground	No
	14		
	15		
	16		

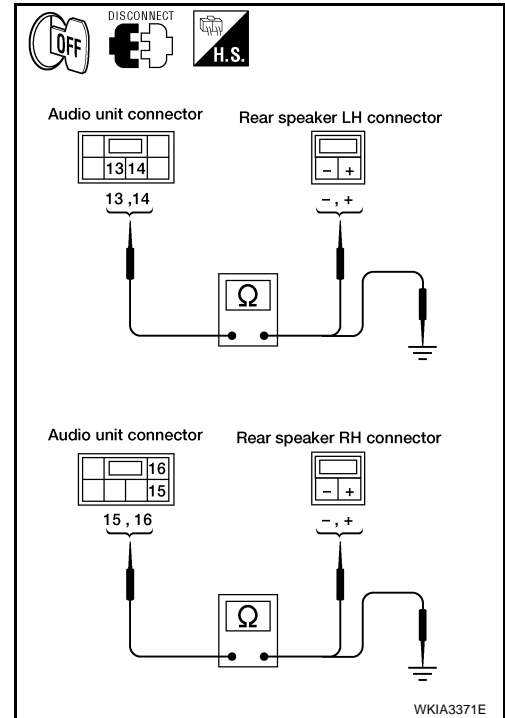

OK or NG

OK >> GO TO 2.

NG >> ● Check connector housings for disconnected or loose terminals.

- Repair harness or connector.

A
B
C
D
E
F
G
H
I
J

AV

L
M

AUDIO

2. REAR SPEAKER SIGNAL CHECK

1. Connect audio unit connector and rear speaker connector.
2. Turn ignition switch to ACC.
3. Push "POWER" switch.
4. Check the signal between audio unit harness connector terminals with CONSULT-II or oscilloscope.

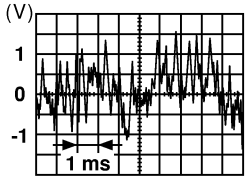
Terminals				Condi- tion	Reference signal
(+)		(-)			
Con- nector	Termi- nal	Con- nector	Terminal		
M44	14	M44	13	Receive audio signal	
	16		15		

SKIA0177E

OK or NG

- OK >> Replace rear door speaker. Refer to [AV-41, "Removal and Installation of Speaker"](#) .
- NG >> Replace audio unit. Refer to [AV-41, "Removal and Installation for Audio Unit"](#) .

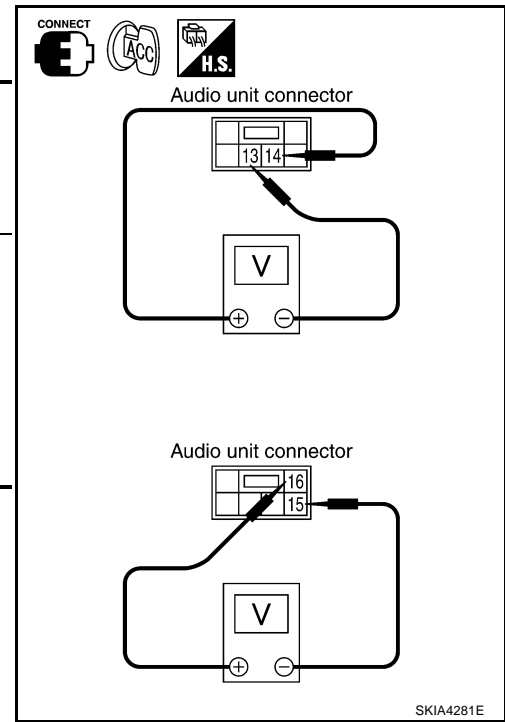

AUDIO

Sound Is Not Heard From Front Door Speaker or Front Tweeter (Premium System)

EKS00E1T

1. HARNESS CHECK

1. Turn ignition switch OFF.
2. Disconnect audio amplifier connector B159 and suspect speaker connector.
3. Check continuity between audio amplifier harness connector terminal B159 and suspect speaker harness connector terminal.

Terminals				Continuity
Audio amplifier		Speaker or tweeter		
Connector	Terminal	Connector	Terminal	
B159	15	D12	+	Yes
	31		-	
	16	D112	+	
	32		-	
	14	M109	+	
	30		-	
	13	M111	+	
	29		-	

4. Check continuity between audio amplifier harness connector terminal B159 and ground.

Terminals				Continuity
Audio amplifier		—	Ground	
Connector	Terminal			
B159	13	Ground		No
	14			
	15			
	16			
	29			
	30			
	31			
	32			

OK or NG

- OK >> GO TO 2.
 NG >> ● Check connector housings for disconnected or loose terminals.
 ● Repair harness or connector.

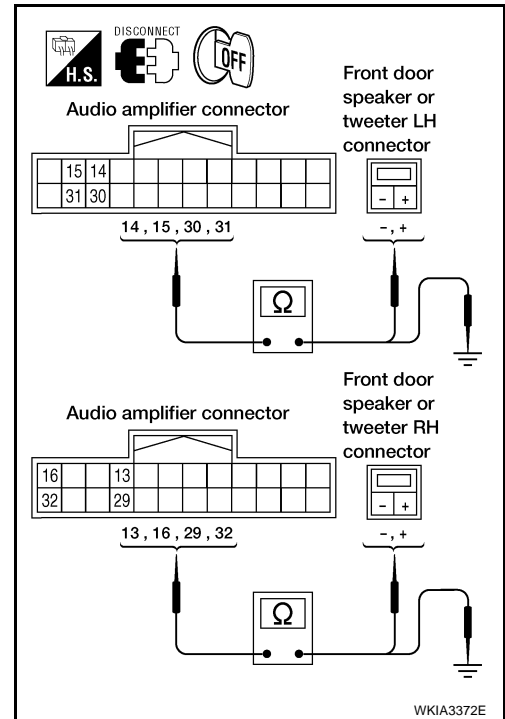

WKIA3372E

AUDIO

2. FRONT SPEAKER SIGNAL CHECK

1. Connect audio amplifier connector B159 and suspect speaker connector.
2. Turn ignition switch to ACC.
3. Push "POWER" switch.
4. Check the signal between audio amplifier harness connector B159 terminals with CONSULT-II or oscilloscope.

Terminals				Condi- tion	Reference signal
(+)		(-)			
Con- nector	Termi- nal	Con- nector	Termi- nal		
B159	13	B159	29	Receive audio signal	
	14		30		
	15		31		
	16		32		

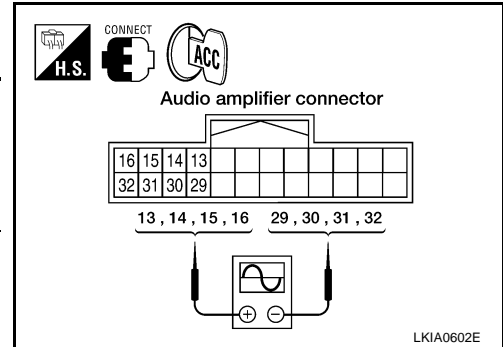

OK or NG

- OK >> Replace suspect speaker. Refer to [AV-41, "Removal and Installation of Speaker"](#) .
- NG >> GO TO 3.

3. HARNESS CHECK

1. Turn ignition switch OFF.
2. Disconnect audio unit connector M43 and audio amplifier connector B159.
3. Check continuity between audio unit harness connector terminals and audio amplifier harness connector terminals.

Terminals				Continuity
Audio unit		Audio amplifier		
Connector	Terminal	Connector	Terminal	
M43	1	B159	6	Yes
	2		22	
	3		5	
	4		21	

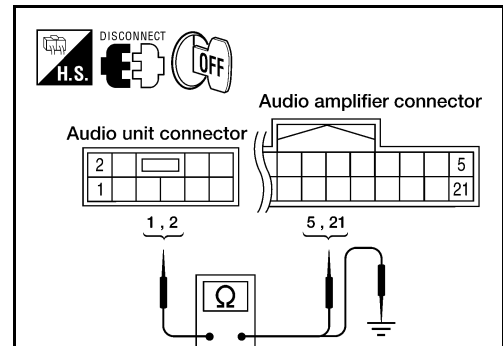

4. Check continuity between audio unit harness connector terminals and ground.

Terminals			Continuity
Audio unit		—	
Connector	Terminal		
M43	1	Ground	No
	2		
	3		
	4		

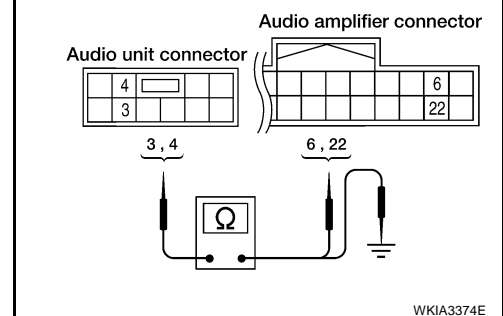

OK or NG

- OK >> GO TO 4.
- NG >> ● Check connector housings for disconnected or loose terminals.
● Repair harness or connector.

AUDIO

4. FRONT SPEAKER SIGNAL CHECK

1. Connect audio unit connector and audio amplifier connector.
2. Turn ignition switch to ACC.
3. Push "POWER" switch.
4. Check the signal between audio unit harness connector terminals with CONSULT-II or oscilloscope.

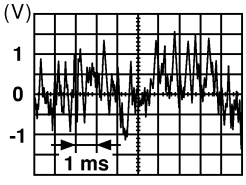
Terminals				Condi- tion	Reference signal
(+)		(-)			
Con- nector	Termi- nal	Con- nector	Termi- nal		
M43	2	M43	1	Receive audio signal	
	4		3		

SKIA0177E

OK or NG

- OK >> Replace audio amplifier. Refer to [AV-43, "Removal and Installation of Audio Amplifier"](#) .
- NG >> Replace audio unit. Refer to [AV-41, "Removal and Installation for Audio Unit"](#) .

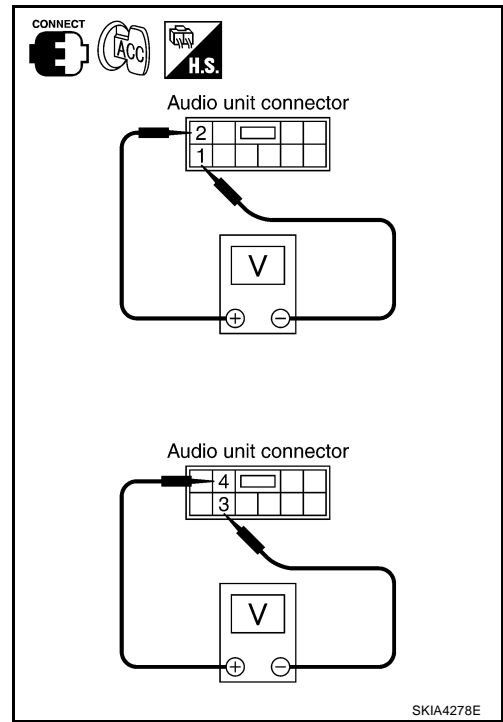

A
B
C
D
E
F
G
H
I
J
L
M

AV

AUDIO

Sound Is Not Heard From Rear Door Speaker or Rear Door Tweeter (Premium System)

EKS00E1U

1. HARNESS CHECK

1. Turn ignition switch OFF.
2. Disconnect audio amplifier connector B159 and suspect speaker connector.
3. Check continuity between audio amplifier harness connector terminal B159 and suspect speaker harness connector terminal.

Terminals				Continuity
Audio amplifier		Speaker or tweeter		
Connector	Terminal	Connector	Terminal	
B159	11	D207	+	Yes
	27		-	
	12	D307	+	
	28		-	
	11	D208	+	
	27		-	
	12	D308	+	
	28		-	

4. Check continuity between audio amplifier harness connector B159 terminal and ground.

Terminals			Continuity
Audio amplifier		—	
Connector	Terminal	—	
B159	11	Ground	No
	27		
	12		
	28		

OK or NG

- OK >> GO TO 2.
- NG >> ● Check connector housings for disconnected or loose terminals.
 - Repair harness or connector.

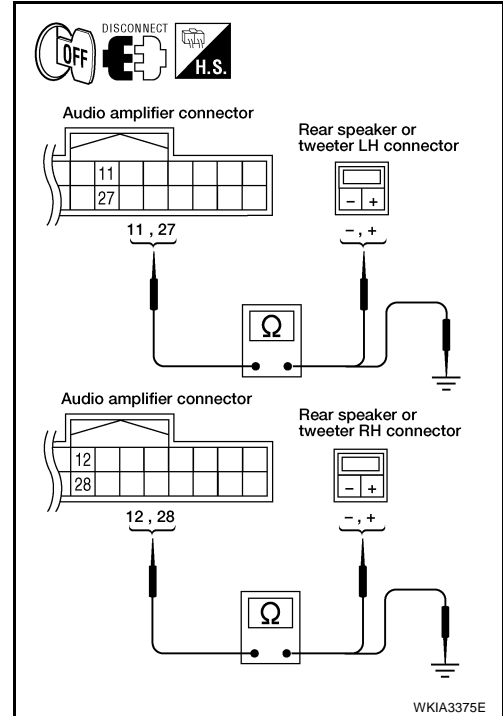

AUDIO

2. REAR SPEAKER SIGNAL CHECK

1. Connect audio amplifier connector B159 and suspect speaker connector.
2. Turn ignition switch to ACC.
3. Push "POWER" switch.
4. Check the signal between audio amplifier harness connector B159 terminals with CONSULT-II or oscilloscope.

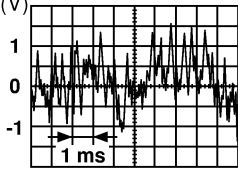
Terminals				Condi- tion	Reference signal
(+)		(-)			
Con- nec- tor	Terminal	Con- nec- tor	Terminal		
B159	11	B159	27	Receive audio signal	
	12		28		

SKIA0177E

OK or NG

- OK >> Replace suspect speaker. Refer to [AV-41, "Removal and Installation of Speaker"](#) .
- NG >> GO TO 3.

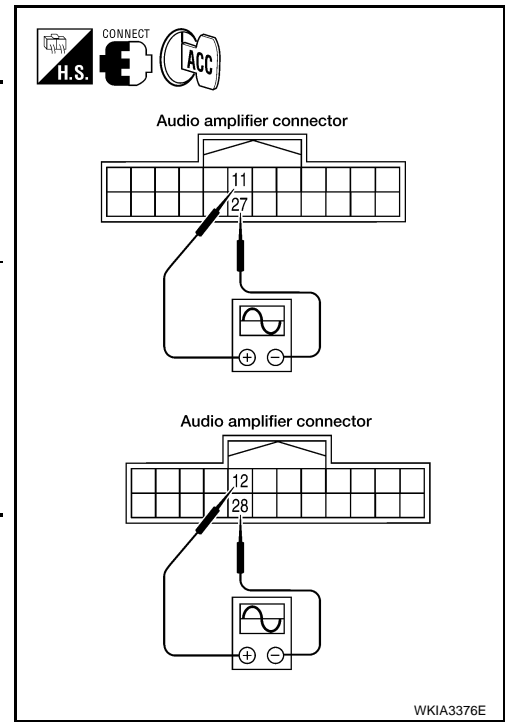

A
B
C
D
E
F
G
H
I
J
L
M

AV

AUDIO

3. HARNESS CHECK

1. Turn ignition switch OFF.
2. Disconnect audio unit connector M44 and audio amplifier connector B159.
3. Check continuity between audio unit harness connector M44 terminals and audio amplifier harness connector B159 terminals.

Terminals				Continuity
Audio unit		Audio amplifier		
Connector	Terminal	Connector	Terminal	
M44	13	B159	8	Yes
	14		24	
	15		7	
	16		23	

4. Check continuity between audio unit harness connector terminal and ground.

Terminals			Continuity
Audio unit		—	
Connector	Terminal		
M44	13	Ground	No
	14		
	15		
	16		

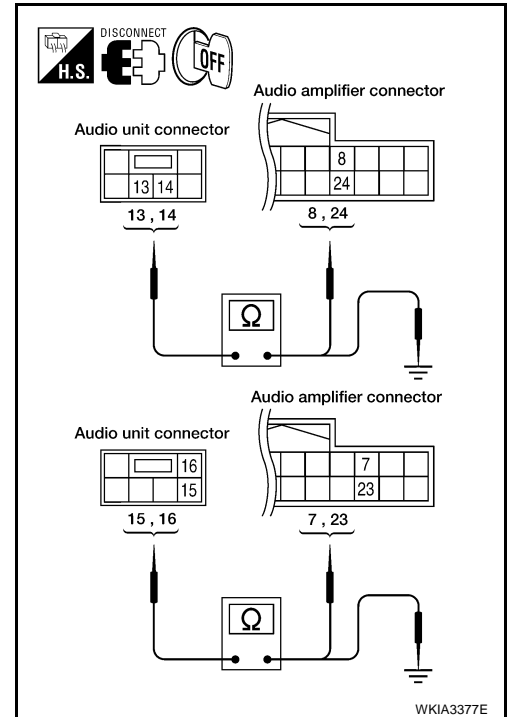

OK or NG

- OK >> GO TO 4.
 NG >> ● Check connector housings for disconnected or loose terminals.
 ● Repair harness or connector.

AUDIO

4. REAR SPEAKER SIGNAL CHECK

1. Connect audio unit connector M44 and audio amplifier connector B159.
2. Turn ignition switch to ACC.
3. Push "POWER" switch.
4. Check the signal between audio unit harness connector M44 terminals with CONSULT-II or oscilloscope.

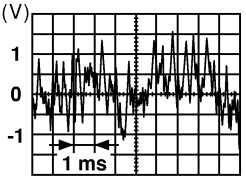
Terminals				Condi- tion	Reference signal
(+)		(-)			
Con- nector	Terminal	Con- nector	Terminal		
M44	14	M44	13	Receive audio signal	
	16		15		

SKIA0177E

OK or NG

- OK >> Replace audio amplifier. Refer to [AV-43, "Removal and Installation of Audio Amplifier"](#) .
- NG >> Replace audio unit. Refer to [AV-41, "Removal and Installation for Audio Unit"](#) .

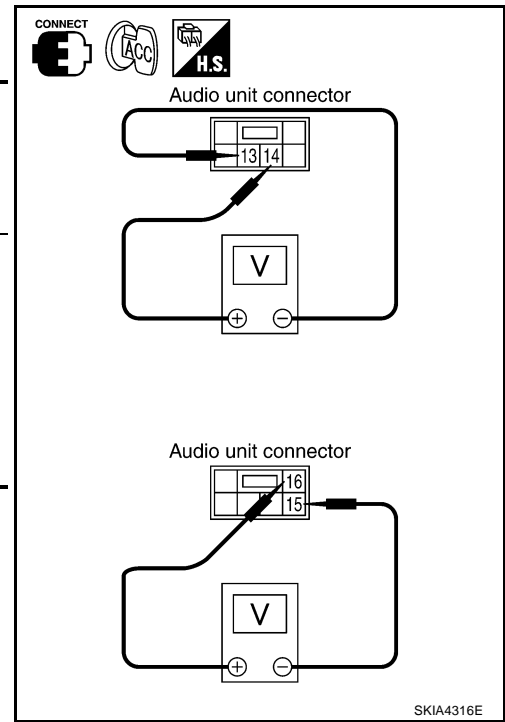

A
B
C
D
E
F
G
H
I
J
L
M

AV

AUDIO

Sound Is Not Heard From Subwoofer (Premium System)

EKS00E1V

1. HARNESS CHECK

1. Turn ignition switch OFF.
2. Disconnect audio amplifier connector B158 and subwoofer connector B72.
3. Check continuity between audio amplifier harness connector terminal and subwoofer harness connector terminal.

Terminals				Continuity
Audio amplifier		Subwoofer		
Connector	Terminal	Connector	Terminal	
B158	2	B72	1	Yes
	3		3	
	18		2	
	19		4	

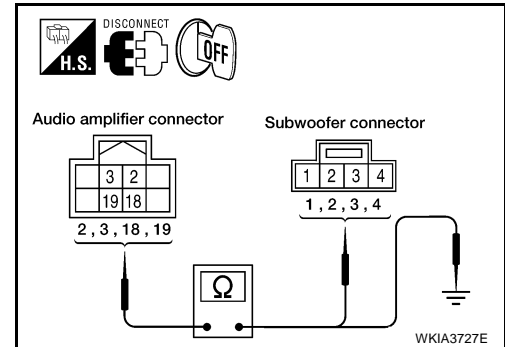

4. Check continuity between audio amplifier harness connector terminal and ground.

Terminals			Continuity
Audio amplifier		—	
Connector	Terminal		
B158	2	Ground	No
	3		
	18		
	19		

OK or NG

OK >> GO TO 2.

- NG >> ● Check connector housings for disconnected or loose terminals.
● Repair harness or connector.

2. SUBWOOFER SIGNAL CHECK

1. Connect audio amplifier connector and subwoofer connector.
2. Turn ignition switch to ACC.
3. Check the signal between audio amplifier harness connector terminals with CONSULT-II or oscilloscope.

Terminals				Condition	Reference signal
(+)		(-)			
Con-connector	Termi-nal	Con-connector	Termi-nal		
B158	2	B158	18	Receive audio signal	
	3		19		

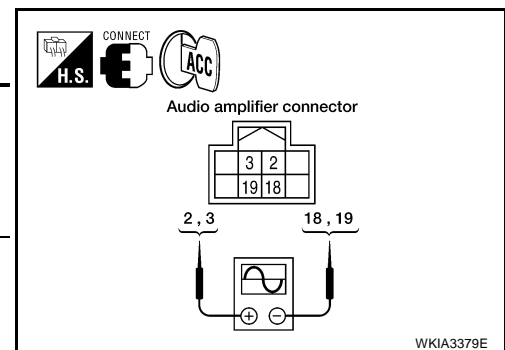

OK or NG

OK >> Replace subwoofer. Refer to [AV-41, "Removal and Installation of Speaker"](#).

NG >> Replace audio amplifier. Refer to [AV-43, "Removal and Installation of Audio Amplifier"](#).

AUDIO

Removal and Installation for Audio Unit

EKS00E1W

REMOVAL

1. Disconnect the negative battery cable.
2. Remove cluster lid C. Refer to [IP-11, "CLUSTER LID C"](#).
3. Using power tool, remove the audio unit screws.
4. Pull out audio unit, then disconnect connectors.

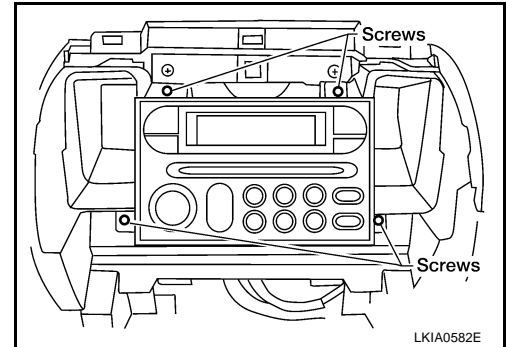

INSTALLATION

Installation is in the reverse order of removal.

Removal and Installation of Speaker

REMOVAL - FRONT DOOR SPEAKER

EKS00E1Y

1. Remove door finisher. Refer to [EI-24, "DOOR FINISHER"](#).
2. Remove the front door speaker screws.
3. Disconnect the connector and remove speaker from front door.

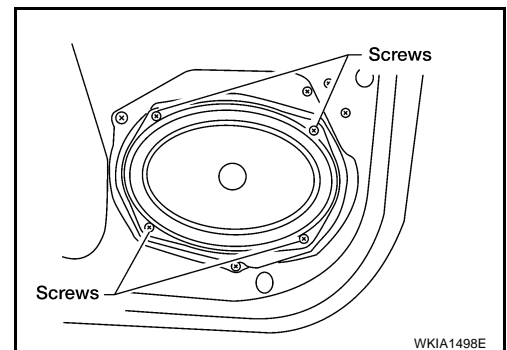

INSTALLATION - FRONT DOOR SPEAKER

Installation is in the reverse order of removal.

Front door speaker screws : 3.5 N-m (0.36 kg-m, 31 in-lb)

REMOVAL - REAR DOOR SPEAKER

1. Remove the rear door finisher. Refer to [EI-25, "REAR DOOR"](#).
2. Remove the rear door speaker screws.
3. Disconnect the connector and remove speaker from rear door.

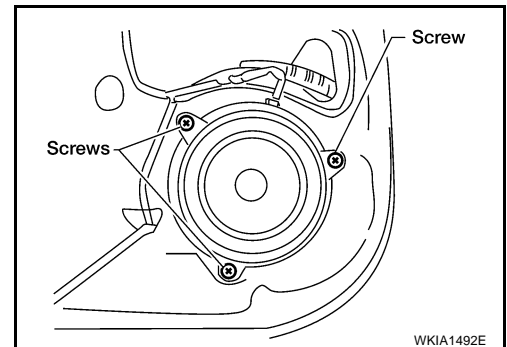

INSTALLATION - REAR DOOR SPEAKER

Installation is in the reverse order of removal.

Rear door speaker screws : 3.5 N-m (0.36 kg-m, 31 in-lb)

A
B
C
D
E
F
G
H
I
J
AV
L
M

AUDIO

REMOVAL - FRONT TWEETER

1. Remove the front tweeter grille.
2. Remove the front tweeter screws.
3. Disconnect the connector, and remove front tweeter from instrument panel.

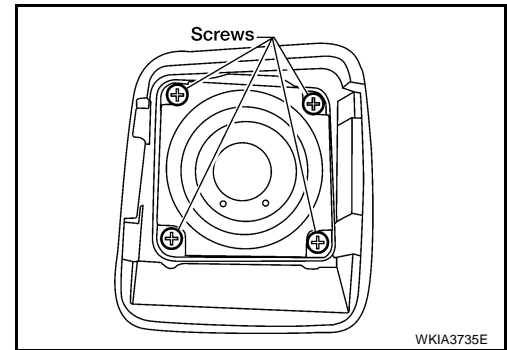

INSTALLATION - FRONT TWEETER

Installation is in the reverse order of removal.

REMOVAL - REAR DOOR TWEETER (PREMIUM SYSTEM)

1. Remove rear door finisher. Refer to [EI-25, "REAR DOOR"](#).
2. Remove the rear door tweeter screws.
3. Remove rear door tweeter from rear door finisher.

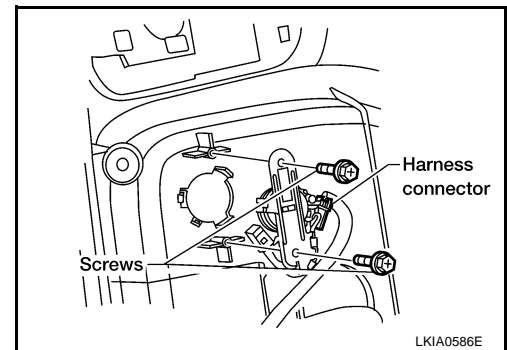

INSTALLATION - REAR DOOR TWEETER (PREMIUM SYSTEM)

Installation is in the reverse order of removal.

Rear door tweeter screws : 3.5 N-m (0.36 kg-m, 31 in-lb)

REMOVAL - SUBWOOFER (PREMIUM SYSTEM)

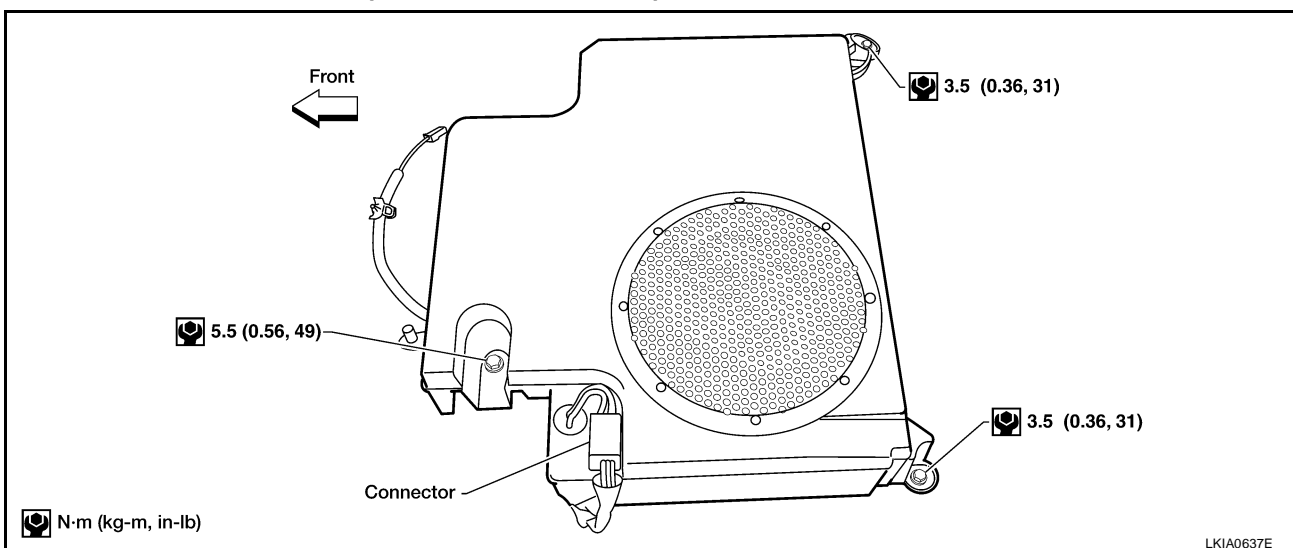

1. Remove the driver side front seat. Refer to [SE-10, "FRONT SEAT"](#).
2. Remove the subwoofer bolts.
3. Disconnect the connector and remove the subwoofer.

INSTALLATION - SUBWOOFER (PREMIUM SYSTEM)

Installation is in the reverse order of removal.

AUDIO

Removal and Installation of Audio Amplifier

EKS00E1Z

REMOVAL

1. Remove passenger side front seat. Refer to [SE-10, "FRONT SEAT"](#) .
 - ⇒: Vehicle front
2. Remove audio amplifier and kick shield screws.
3. Disconnect the connectors (1) and remove audio amplifier from the bracket.

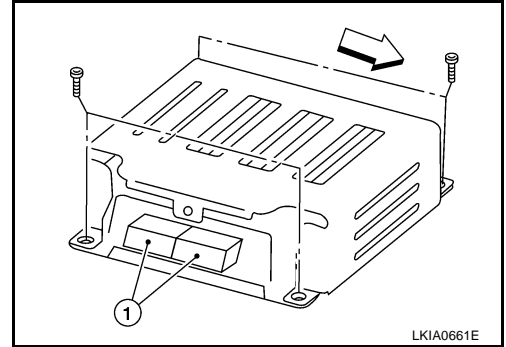

INSTALLATION

Installation is in the reverse order of removal.

Removal and Installation of Steering Wheel Audio Control Switches

EKS00E20

REMOVAL

1. Remove driver air bag module. Refer to [SRS-42, "Removal and Installation"](#) .
2. Remove steering wheel audio control switch assembly screws.
3. Disconnect the switch connector, and remove from steering wheel.

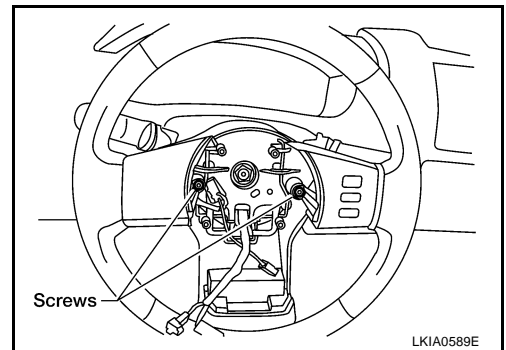

INSTALLATION

Installation is in the reverse order of removal.

A
B
C
D
E
F
G
H
I
J
AV
L
M

AUDIO ANTENNA

AUDIO ANTENNA

PFP:28200

Location of Antenna

EKS00E21

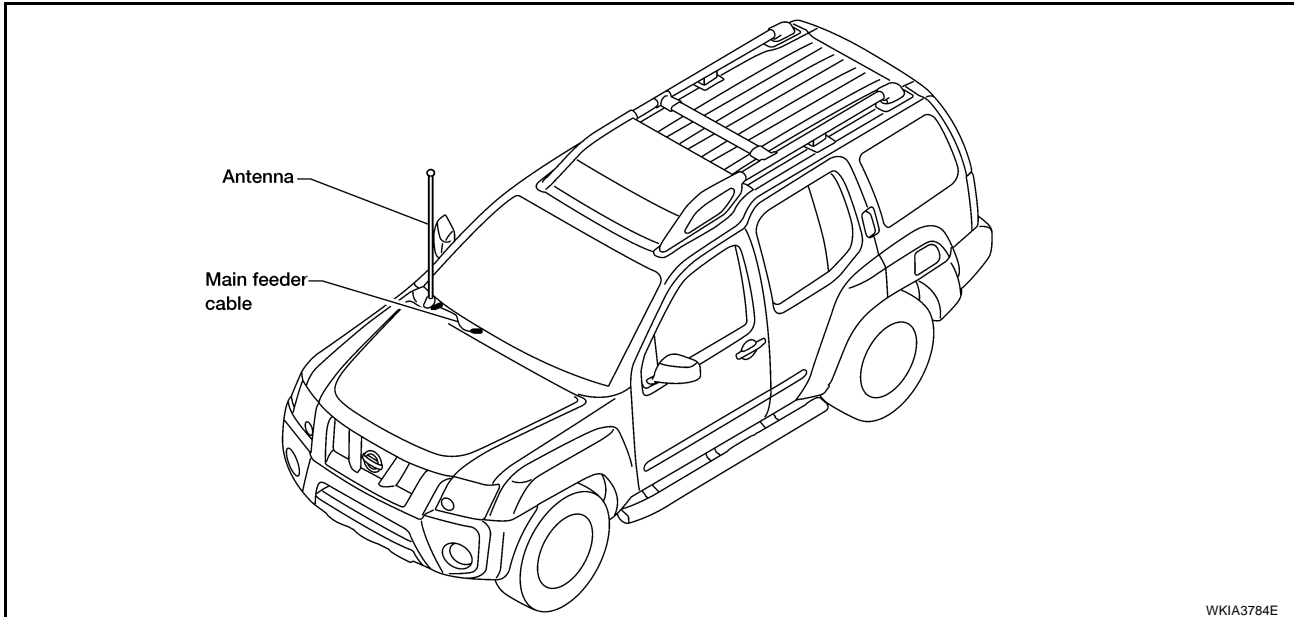

Fixed Antenna Rod Replacement REMOVAL

EKS00E22

1. Remove antenna rod.
2. Remove rubber seal.
3. Remove cowl top. Refer to [EI-17, "COWL TOP"](#) .
4. Remove antenna base bolts.
5. Remove audio unit. Refer to [AV-41, "Removal and Installation for Audio Unit"](#) .
6. Disconnect antenna cable from audio unit.
7. Remove antenna base and cable.

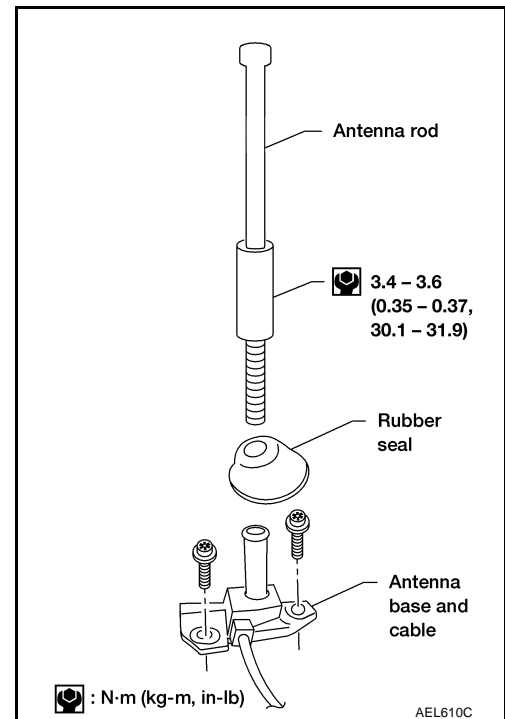

INSTALLATION

Installation is in the reverse order of removal.

CAUTION:

Always properly tighten the antenna rod during installation or the antenna rod may bend or break during vehicle operation.