

A
CO
C
D
E
F
G
H
I
J
K
L
M

SECTION CO

ENGINE COOLING SYSTEM

CONTENTS

<p>PRECAUTIONS 2</p> <p style="padding-left: 20px;">Precautions for Liquid Gasket 2</p> <p style="padding-left: 40px;">REMOVAL OF LIQUID GASKET SEALING 2</p> <p style="padding-left: 40px;">LIQUID GASKET APPLICATION PROCEDURE..... 2</p> <p>PREPARATION 3</p> <p style="padding-left: 20px;">Special Service Tools 3</p> <p style="padding-left: 20px;">Commercial Service Tools 4</p> <p>OVERHEATING CAUSE ANALYSIS 5</p> <p style="padding-left: 20px;">Troubleshooting Chart 5</p> <p>COOLING SYSTEM 7</p> <p style="padding-left: 20px;">Cooling Circuit 7</p> <p style="padding-left: 20px;">System Chart 8</p> <p>ENGINE COOLANT 9</p> <p style="padding-left: 20px;">System Check 9</p> <p style="padding-left: 40px;">CHECKING COOLING SYSTEM HOSES 9</p> <p style="padding-left: 40px;">CHECKING RESERVOIR LEVEL 9</p> <p style="padding-left: 40px;">CHECKING COOLING SYSTEM FOR LEAKS..... 9</p> <p style="padding-left: 40px;">CHECKING RESERVOIR CAP 10</p> <p style="padding-left: 40px;">CHECKING RADIATOR 10</p> <p style="padding-left: 20px;">Refilling Engine Coolant 10</p> <p>RADIATOR 11</p> <p style="padding-left: 20px;">Removal and Installation 11</p> <p style="padding-left: 40px;">REMOVAL 11</p> <p style="padding-left: 40px;">INSTALLATION 13</p> <p style="padding-left: 40px;">INSPECTION AFTER INSTALLATION 13</p> <p>ENGINE COOLING FAN 14</p> <p style="padding-left: 20px;">Removal and Installation (Crankshaft driven type).. 14</p> <p style="padding-left: 40px;">REMOVAL 14</p> <p style="padding-left: 40px;">INSPECTION AFTER REMOVAL 14</p>	<p style="padding-left: 40px;">INSTALLATION 14</p> <p style="padding-left: 40px;">INSPECTION AFTER INSTALLATION 15</p> <p style="padding-left: 20px;">Removal and Installation (Motor driven type) 15</p> <p style="padding-left: 40px;">REMOVAL 15</p> <p style="padding-left: 40px;">INSTALLATION 15</p> <p>WATER PUMP 16</p> <p style="padding-left: 20px;">Removal and Installation 16</p> <p style="padding-left: 40px;">REMOVAL 16</p> <p style="padding-left: 40px;">INSPECTION AFTER REMOVAL 18</p> <p style="padding-left: 40px;">INSTALLATION 18</p> <p style="padding-left: 40px;">INSPECTION AFTER INSTALLATION 19</p> <p>WATER INLET AND THERMOSTAT ASSEMBLY ... 21</p> <p style="padding-left: 20px;">Removal and Installation 21</p> <p style="padding-left: 40px;">REMOVAL 21</p> <p style="padding-left: 40px;">INSPECTION AFTER REMOVAL 21</p> <p style="padding-left: 40px;">INSTALLATION 22</p> <p style="padding-left: 40px;">INSPECTION AFTER INSTALLATION 22</p> <p>WATER OUTLET AND WATER PIPING 23</p> <p style="padding-left: 20px;">Removal and Installation 23</p> <p style="padding-left: 40px;">REMOVAL 23</p> <p style="padding-left: 40px;">INSTALLATION 23</p> <p style="padding-left: 40px;">INSPECTION AFTER INSTALLATION 23</p> <p>SERVICE DATA AND SPECIFICATIONS (SDS) 25</p> <p style="padding-left: 20px;">Standard and Limit 25</p> <p style="padding-left: 40px;">ENGINE COOLANT CAPACITY (APPROXI- MATE) 25</p> <p style="padding-left: 40px;">RADIATOR 25</p> <p style="padding-left: 40px;">THERMOSTAT 25</p>
--	--

PRECAUTIONS

PRECAUTIONS

PFP:00001

Precautions for Liquid Gasket REMOVAL OF LIQUID GASKET SEALING

EBS00NLV

- After removing nuts and bolts, separate the mating surface, using Tool and remove old liquid gasket sealing.

Tool number : KV10111100 (J-37228)

CAUTION:

Be careful not to damage the mating surfaces.

- Tap Tool to insert it, and then slide it by tapping on the side as shown.
- In areas where Tool is difficult to use, use plastic hammer to lightly tap the parts, to remove it.

CAUTION:

If for some unavoidable reason suitable tool such as screwdriver is used, be careful not to damage the mating surfaces.

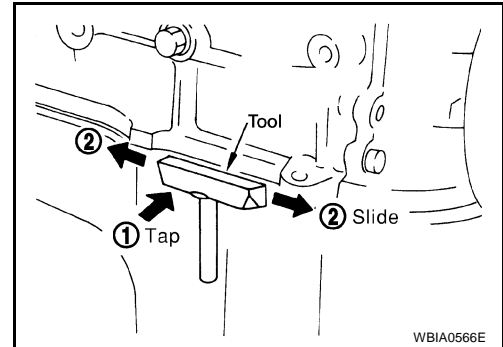

LIQUID GASKET APPLICATION PROCEDURE

- Remove old liquid gasket adhering to the liquid gasket application surface and the mating surface, Using scraper.
 - Remove liquid gasket completely from the groove of the liquid gasket application surface, bolts, and bolt holes.
- Thoroughly clean the mating surfaces and remove adhering moisture, grease and foreign materials.

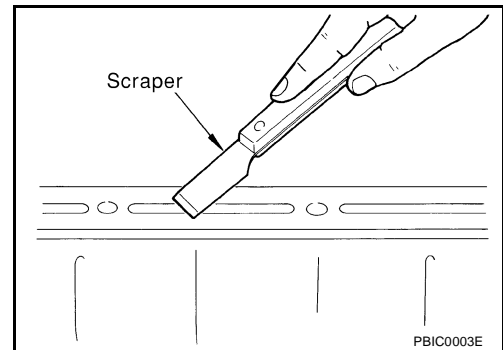

- Attach liquid gasket tube to Tool.

Tool number : WS39930000 (—)

Use Genuine RTV Silicone Sealant or equivalent. Refer to GI-46, "Recommended Chemical Products and Sealants".

- Apply liquid gasket without breaks to the specified location with the specified dimensions.
 - If there is a groove for the liquid gasket application, apply liquid gasket to the groove.

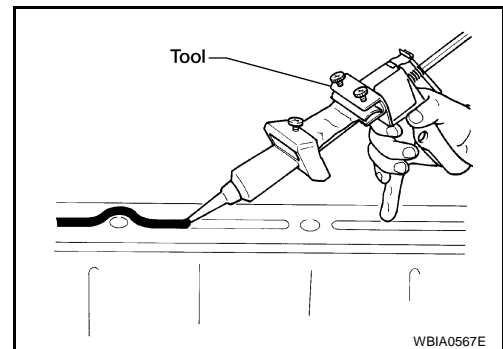

- As for the bolt holes, normally apply liquid gasket inside the holes. Occasionally, it should be applied outside the holes. Make sure to read the text of service manual.
- Within five minutes of liquid gasket application, install the mating component.
- If liquid gasket protrudes, wipe it off immediately.
- Do not retighten nuts or bolts after the installation.
- After 30 minutes or more have passed from the installation, fill engine oil and engine coolant.

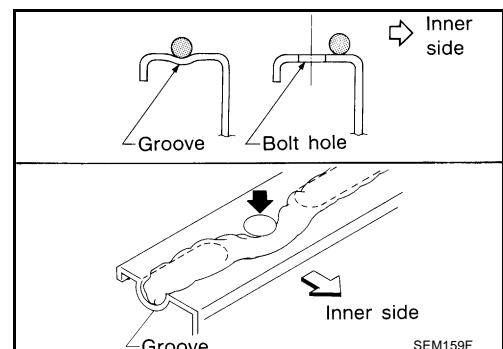

CAUTION:

If there are specific instructions in this manual, observe them.

PREPARATION

PF0:00002

PREPARATION

Special Service Tools

EBS00NLW

The actual shapes of Kent-Moore tools may differ from those of special service tools illustrated here.

Tool number (Kent-Moore No.) Tool name	Description
EG17650301 (J-33984-A) Radiator cap tester adapter	Adapting radiator cap tester to radiator cap and radiator filler neck a: 28 (1.10) dia. b: 31.4 (1.236) dia. c: 41.3 (1.626) dia. Unit: mm (in)
KV10111100 (J-37228) Seal cutter	Removing chain tensioner cover and water pump cover
WS39930000 (—) Tube presser	Pressing the tube of liquid gasket
— (J-23688) Engine coolant refractometer	Checking concentration of ethylene glycol in engine coolant

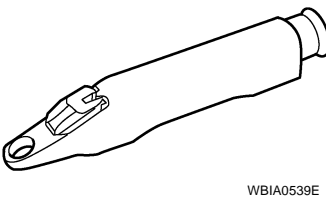
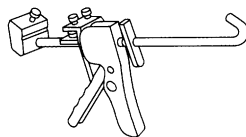
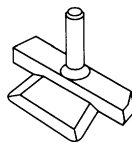
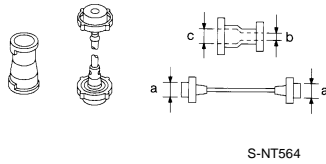

A
CO
C
D
E
F
G
H
I
J
K
L
M

PREPARATION

Commercial Service Tools

EBS00NLX

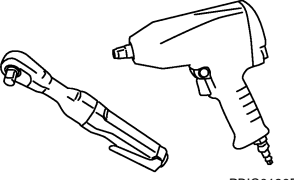
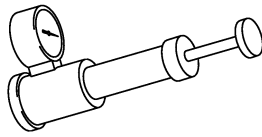
Tool name	Description
<p data-bbox="162 247 267 273">Power tool</p>  <p data-bbox="852 451 917 472">PBIC0190E</p>	<p data-bbox="1006 247 1266 273">Loosening nuts and bolts</p>
<p data-bbox="162 483 349 508">Radiator cap tester</p>  <p data-bbox="852 682 917 703">PBIC1982E</p>	<p data-bbox="1006 483 1356 508">Checking radiator and radiator cap</p>

OVERHEATING CAUSE ANALYSIS

OVERHEATING CAUSE ANALYSIS

PFP:00012

Troubleshooting Chart

EBS00ONLY

		Symptom		Check items	
Cooling system parts malfunction	Poor heat transfer	Water pump malfunction	Worn or loose drive belt	—	CO
		Thermostat stuck closed	—		
		Damaged fins	Dust contamination or paper clogging		
		Heater pump	Physical damage		
		Clogged radiator cooling tube	Excess foreign material (rust, dirt, sand, etc.)		
	Reduced air flow	Cooling fan does not operate	Fan assembly	—	E
		High resistance to fan rotation			
		Damaged fan blades			
	Damaged radiator shroud	—	—	—	F
	Improper engine coolant mixture ratio	—	—	—	G
	Poor engine coolant quality	—	Engine coolant viscosity	—	H
	Insufficient engine coolant	Engine coolant leaks	Cooling hose	Loose clamp	I
				Cracked hose	
			Water pump	Poor sealing	
			Radiator cap	Loose Poor sealing	
Radiator		O-ring for damage, deterioration or improper fitting	J		
		Cracked radiator tank			
		Cracked radiator core			
Reservoir tank	Cracked reservoir tank	K			
Overflowing reservoir tank	Exhaust gas leaks into cooling system	Cylinder head deterioration	L		
		Cylinder head gasket deterioration			

OVERHEATING CAUSE ANALYSIS

	Symptom		Check items	
Except cooling system parts malfunction	—	Overload on engine	Abusive driving	High engine rpm under no load
				Driving in low gear for extended time
				Driving at extremely high speed
			Powertrain system malfunction	—
			Installed improper size wheels and tires	
	Dragging brakes			
			Improper ignition timing	
	Blocked or restricted air flow	Blocked bumper	—	—
		Blocked radiator grille	Installed car brassiere	
			Mud contamination or paper clogging	
Blocked radiator		—		
Blocked condenser		Blocked air flow		
Installed large fog lamp				

COOLING SYSTEM

COOLING SYSTEM

PFP:21020

Cooling Circuit

EBS00NLZ

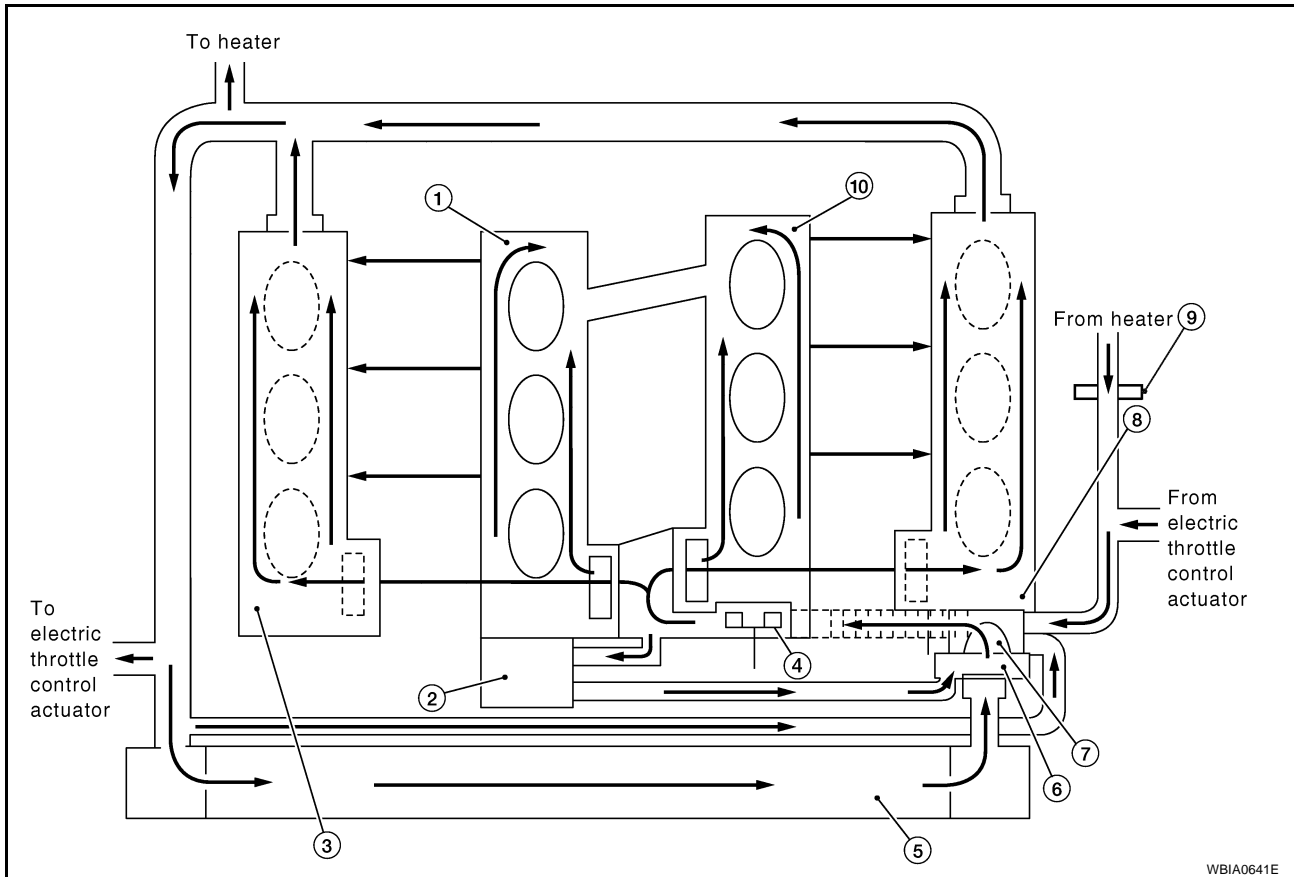

- | | | |
|-------------------------|-----------------------|-----------------------|
| 1. Cylinder block (RH) | 2. Oil cooler | 3. Cylinder head (RH) |
| 4. Water pump | 5. Radiator | 6. Water inlet |
| 7. Thermostat | 8. Cylinder head (LH) | 9. Heater pump |
| 10. Cylinder block (LH) | | |

COOLING SYSTEM

System Chart

EBS00NM0

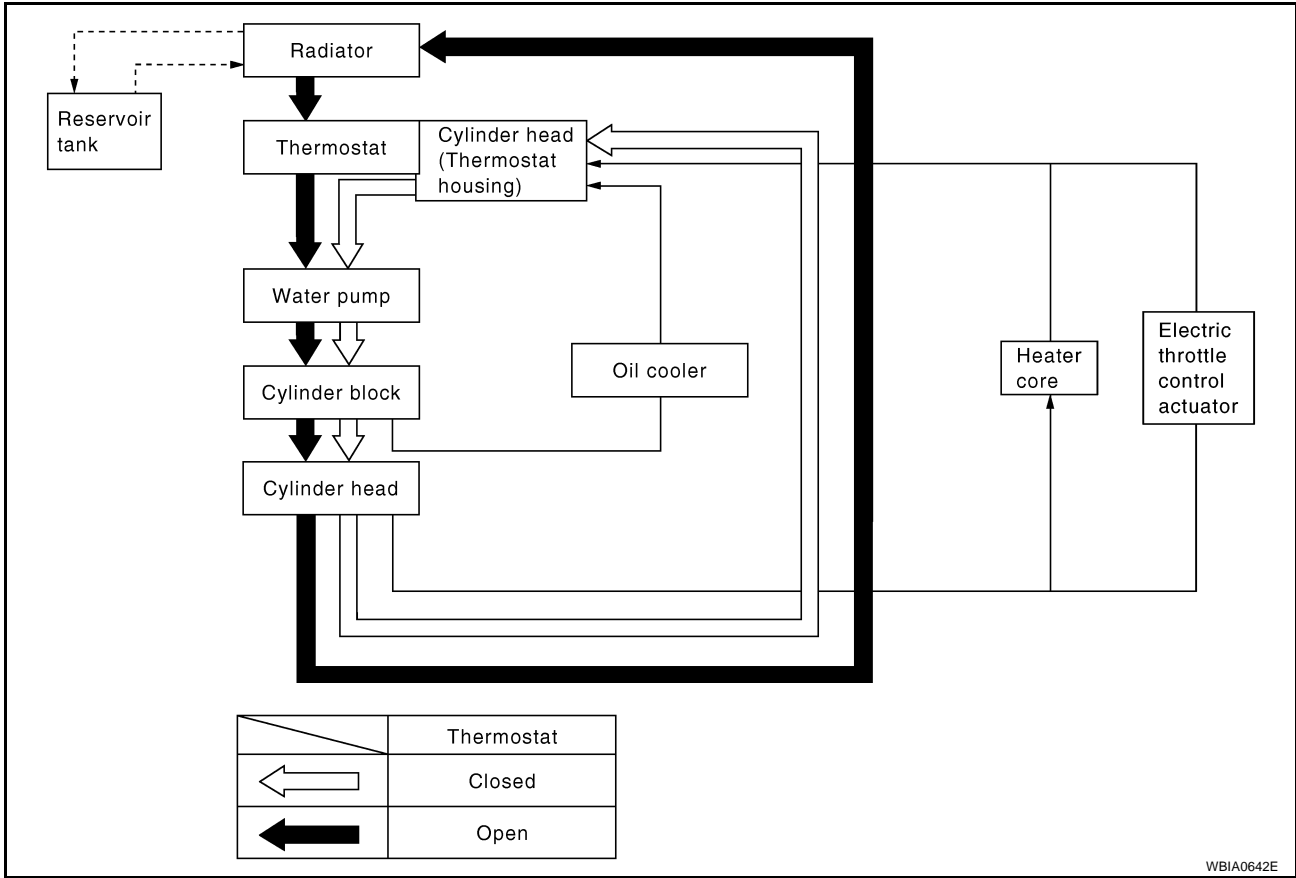

WBIA0642E

ENGINE COOLANT

PFP:KQ100

ENGINE COOLANT

System Check

EBS00NM1

WARNING:

- Never remove the radiator/reservoir cap when the engine is hot. Serious burns could occur from high pressure fluid escaping from the radiator.
- Wrap a thick cloth around the cap. Slowly push down and turn it a quarter turn to allow built-up pressure to escape. Carefully remove the cap by pushing down and turning it all the way.

CHECKING COOLING SYSTEM HOSES

Check hoses for the following:

- Improper attachment
- Leaks
- Cracks
- Damage
- Loose connections
- Chafing
- Deterioration

CHECKING RESERVOIR LEVEL

- Check if the reservoir tank coolant level is within MIN to MAX when the engine is cool.
- Adjust coolant level if it is too much or too little.

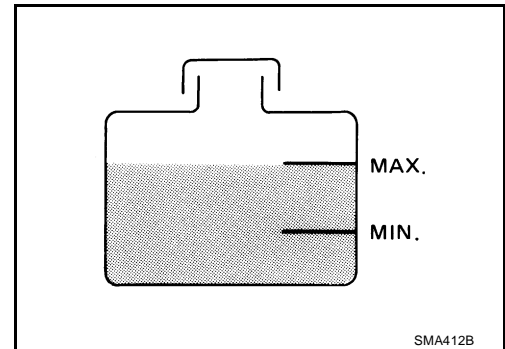

CHECKING COOLING SYSTEM FOR LEAKS

To check for leakage, apply pressure to the cooling system using Tool.

Tool number : EG17650301 (J-33984-A)

Testing pressure : 137 kPa (1.4 kg/cm² , 20 psi)

WARNING:

Never remove the radiator/reservoir cap when the engine is hot. Serious burns could occur from high pressure coolant escaping from the radiator.

CAUTION:

Higher pressure than specified may cause radiator damage.

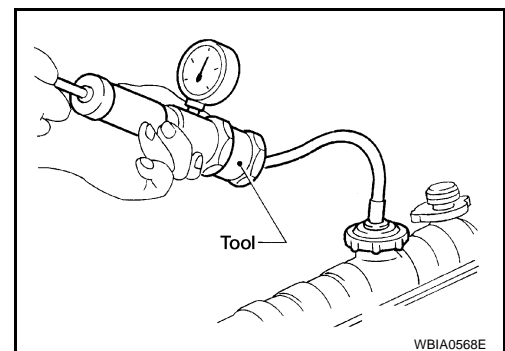

ENGINE COOLANT

CHECKING RESERVOIR CAP

1. Check reservoir cap relief pressure using Tool.

Tool number : EG17650301 (J-33984-A)

Standard: 78 – 98 kPa (0.8 – 1.0 kg/cm² , 11 – 14 psi)

Limit: 59 kPa (0.6 kg/cm² , 9 psi)

- When connecting the reservoir cap to the tester, apply water or coolant to the cap seal surface.
- Replace the reservoir cap if there is an abnormality in the negative-pressure valve, or if the open-valve pressure is outside of the standard values.

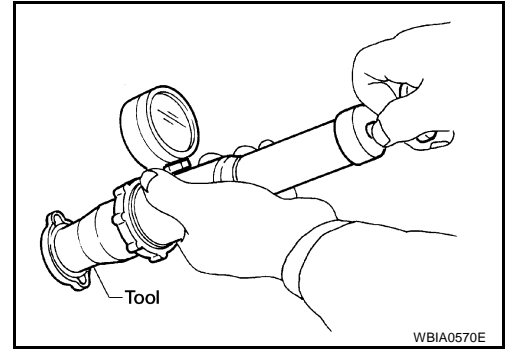

CHECKING RADIATOR

Check radiator for mud or clogging. If necessary, clean radiator as follows.

- Be careful not to bend or damage the radiator fins.
 - When radiator is cleaned without removal, remove all surrounding parts such as cooling fan shroud and horns. Then tape the harness and electrical connectors to prevent water from entering.
1. Apply water by hose to the back side of the radiator core, with the hose pointed vertically downward.
 2. Apply water again to all radiator core surfaces once per minute.
 3. Stop washing if any stains no longer flow out from the radiator.
 4. Blow air into the back side of radiator core, with the air hose pointed vertically downward.
- Use compressed air lower than 490 kPa (5 kg/cm² , 71 psi) and keep distance more than 30 cm (11.8 in).
5. Blow air again into all the radiator core surfaces once per minute until no water sprays out.
 6. Check for leaks.

Refilling Engine Coolant

EBS00NM2

Changing the engine coolant is part of the required maintenance of the engine. Refer to [CO-9, "ENGINE COOLANT"](#) .

RADIATOR

PF21400

EBS00NM3

RADIATOR

Removal and Installation

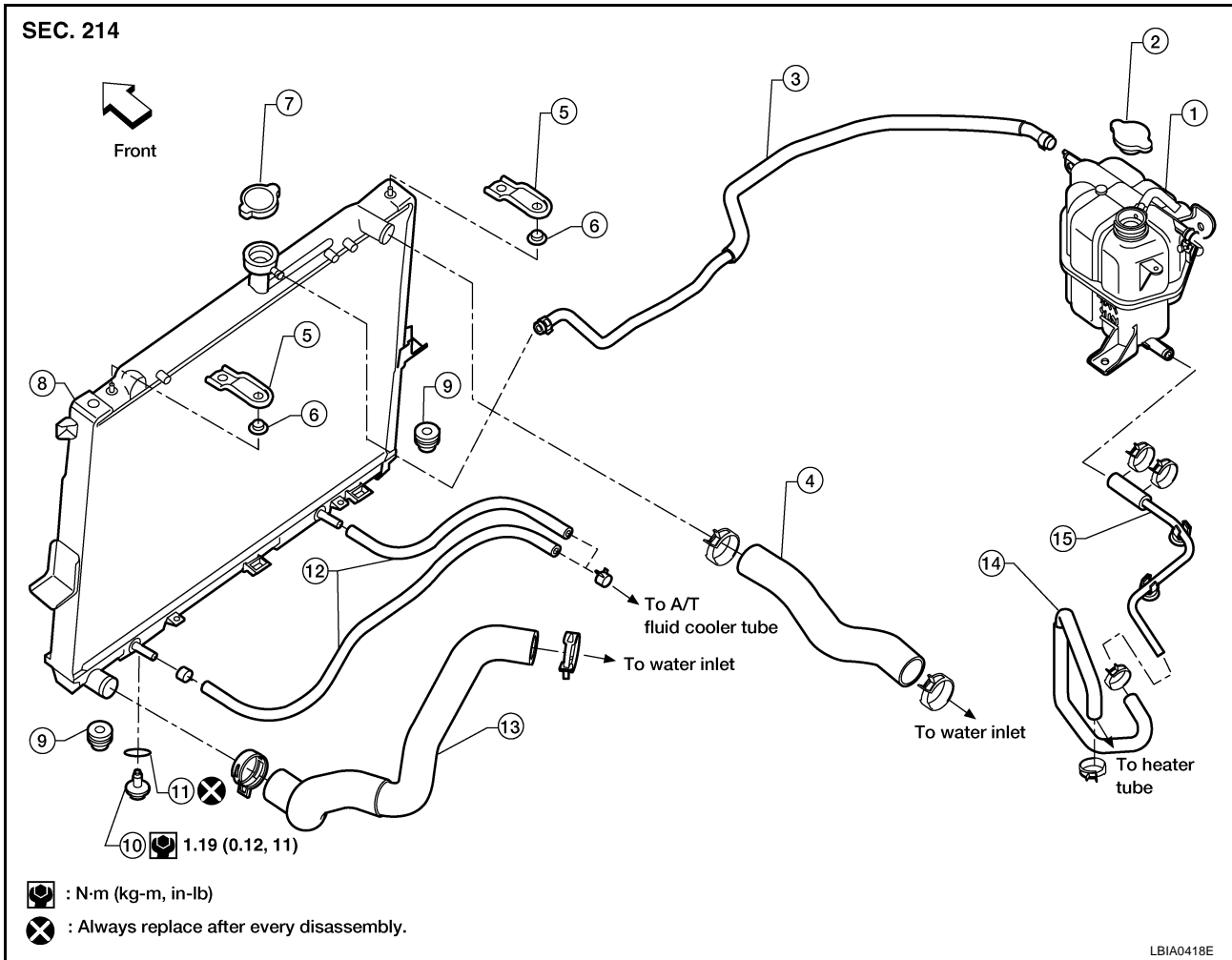

- | | | |
|---------------------------|------------------------|----------------------------|
| 1. Reservoir tank | 2. Reservoir tank cap | 3. Reservoir tank hose |
| 4. Radiator hose (upper) | 5. Upper mount bracket | 6. Mounting rubber (upper) |
| 7. Radiator cap | 8. Radiator | 9. Mounting rubber (lower) |
| 10. Radiator drain plug | 11. O-ring | 12. A/T fluid cooler hose |
| 13. Radiator hose (lower) | 14. Heater bypass hose | 15. Heater bypass tube |

WARNING:

Do not remove radiator cap when engine is hot. Serious burns could occur from high-pressure engine coolant escaping from radiator. Wrap a thick cloth around the cap. Slowly turn it a quarter of a turn to release built-up pressure. Carefully remove radiator cap by turning it all the way.

REMOVAL

1. Remove engine cover with power tool. Refer to [EM-12, "Removal and Installation"](#).
2. Drain engine coolant from radiator. Refer to [CO-9, "ENGINE COOLANT"](#).

CAUTION:

- Perform this step when engine is cold.
- Do not spill engine coolant on drive belts.

3. Remove air duct and air cleaner case assembly. Refer to [EM-15, "Removal and Installation"](#).
4. Remove reservoir tank hose.
5. Removal radiator hoses (upper and lower) and reservoir tank hose.

CAUTION:

Be careful not to allow engine coolant to contact drive belts.

6. Remove radiator cooling fan assembly. Refer to [CO-14, "ENGINE COOLING FAN"](#).

RADIATOR

7. Disconnect A/T fluid cooler hoses. (A/T models)
 - Install blind plug to avoid leakage of A/T fluid.
8. Remove the upper mount bracket bolts.

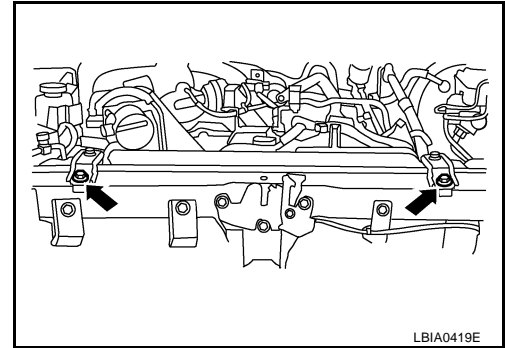

9. Remove the two A/C condenser bolts.

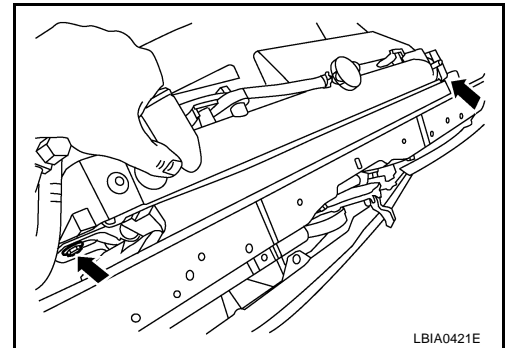

10. Remove radiator as follows:

CAUTION:

Do not damage or scratch A/C condenser and radiator core when removing.

- a. With lifting and pulling radiator in a rear direction, disassemble lower mount from radiator core support center.

CAUTION:

Because A/C condenser is onto the front-lower portion of radiator, moving to rear direction should be at minimum.

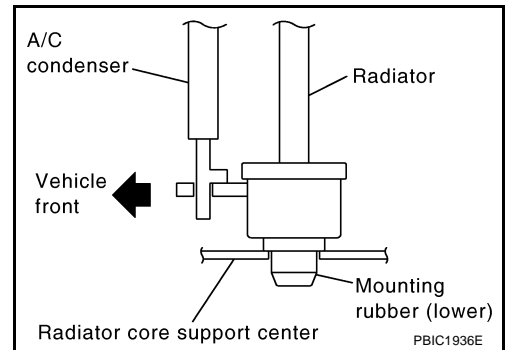

- b. Lift A/C condenser up and remove radiator after disengaging the fitting as front-bottom surface.

CAUTION:

Lifting A/C condenser should be minimum to prevent a load to A/C piping.

- c. After removing radiator, put A/C condenser on radiator core support center to prevent a load to A/C piping, and temporarily fix it with rope or similar means.

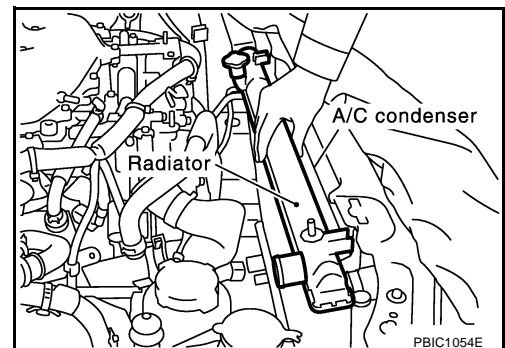

RADIATOR

INSTALLATION

Installation is in the reverse order of removal.

INSPECTION AFTER INSTALLATION

- Check for leaks of engine coolant using tool. Refer to [CO-9, "CHECKING COOLING SYSTEM FOR LEAKS"](#).
- Start and warm up engine. Visually check there are no leaks of engine coolant and A/T fluid.

A

CO

C

D

E

F

G

H

I

J

K

L

M

ENGINE COOLING FAN

PF2:21140

ENGINE COOLING FAN

Removal and Installation (Crankshaft driven type)

EBS00NM4

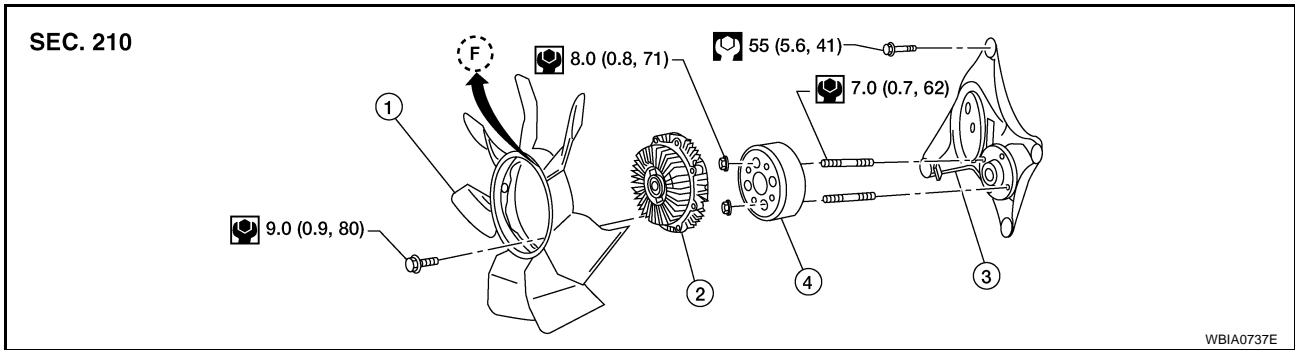

1. Cooling fan
2. Fan coupling
3. Fan bracket
4. Cooling fan pulley

REMOVAL

1. Remove air duct. Refer to [EM-15, "Removal and Installation"](#).
2. Remove the engine front undercover.
3. Remove the upper and lower radiator shrouds. Refer to [CO-11, "Removal and Installation"](#).
4. Remove drive belts. Refer to [EM-13, "Removal and Installation"](#).
5. Remove cooling fan.

INSPECTION AFTER REMOVAL

Fan Coupling

Inspect fan coupling for oil leakage and bimetal conditions.

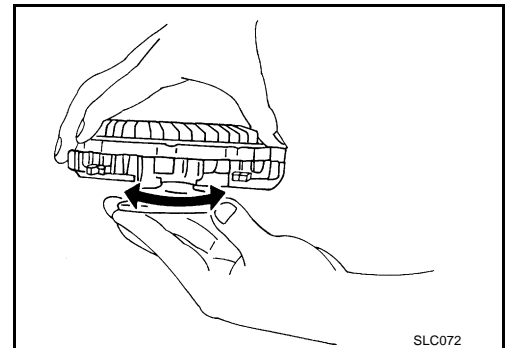

Fan Bracket

- Visually check that there is no significant looseness in the fan bracket shaft, and that it turns smoothly by hand.
- If there are any unusual concerns, replace the fan bracket assembly.

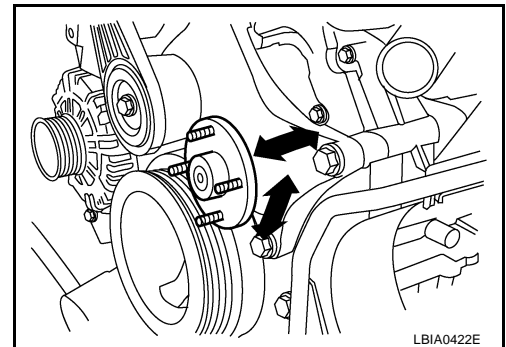

INSTALLATION

Installation is in the reverse order of removal.

- Install cooling fan with its front mark "F" facing front of engine. Refer to [CO-14, "Removal and Installation \(Crankshaft driven type\)"](#).

ENGINE COOLING FAN

INSPECTION AFTER INSTALLATION

- Check for leaks of the engine coolant using tool. Refer to [CO-9, "CHECKING COOLING SYSTEM FOR LEAKS"](#) .
- Start and warm up the engine. Visually make sure that there are no leaks of the engine coolant.

Removal and Installation (Motor driven type)

REMOVAL

1. Remove radiator upper and lower shroud. Refer to [CO-11, "Removal and Installation"](#) .
2. Disconnect harness connector from fan motor.
3. Remove the bolt and remove the fan grille and motor assembly.

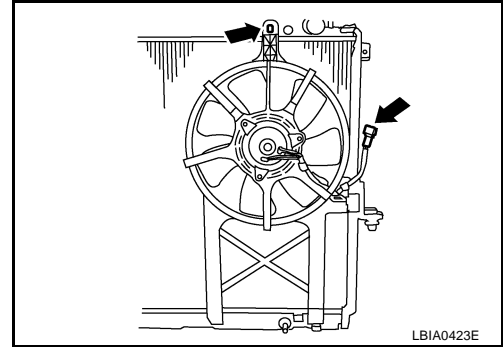

INSTALLATION

Installation is in the reverse order of removal.

- Cooling fan is controlled by ECM. For details, refer to [EC-466, "Cooling Fan Operation"](#) .

WATER PUMP

PFP:21020

EBS00NM6

WATER PUMP

Removal and Installation

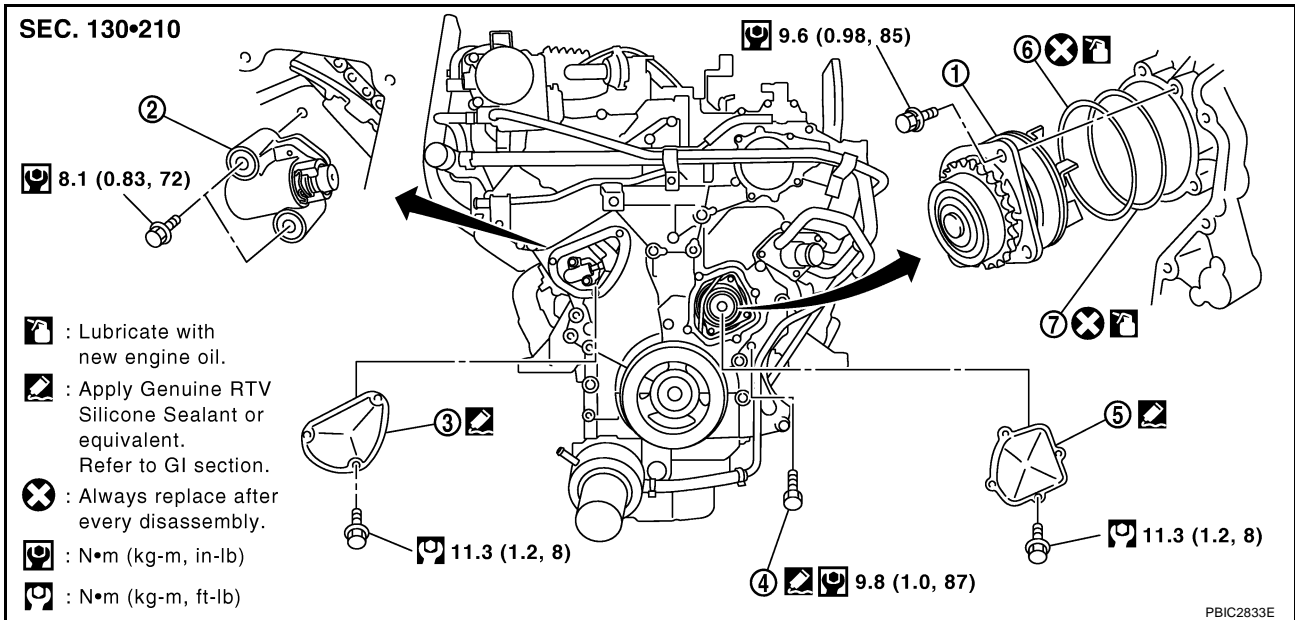

- | | | |
|-----------------------------|-------------------------------------|--------------------------|
| 1. Water pump | 2. Timing chain tensioner (primary) | 3. Chain tensioner cover |
| 4. Water drain plug (front) | 5. Water pump cover | 6. O-ring |
| 7. O-ring | | |

CAUTION:

- When removing water pump assembly, be careful not to get engine coolant on drive belts.
- Water pump cannot be disassembled and should be replaced as a unit.
- After installing water pump, connect hose and clamp securely, then check for leaks using tool.

REMOVAL

1. Remove undercover with power tool.
2. Remove drive belts. Refer to [EM-13, "Removal and Installation"](#).
3. Drain engine coolant. Refer to [CO-9, "ENGINE COOLANT"](#).

CAUTION:

- Perform this step when engine is cold.
 - Do not spill engine coolant on drive belts.
4. Remove radiator hoses (upper and lower) and cooling fan assembly. Refer to [CO-14, "ENGINE COOLING FAN"](#).
 5. Remove chain tensioner cover and water pump cover from front timing chain case, using Tool.

Tool number : KV10111100 (J-37228)

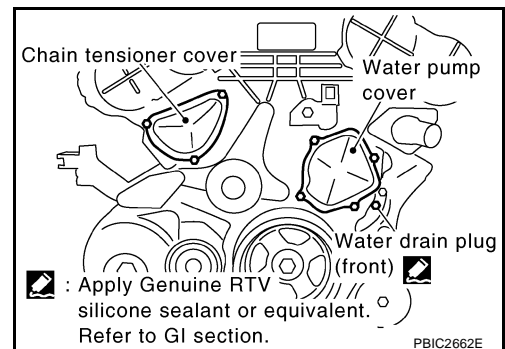

WATER PUMP

6. Remove timing chain tensioner (primary) as follows:

- a. Loosen clip of timing chain tensioner (primary), and release plunger stopper. (1)
- b. Insert plunger into tensioner body by pressing slack guide. (2)
- c. Keep slack guide pressed and hold plunger in by pushing stopper pin through the tensioner body hole and plunger groove. (3)

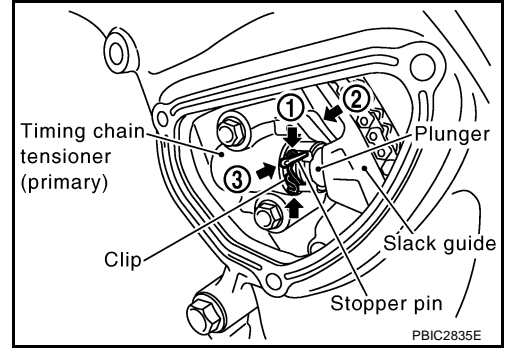

- d. Turn crankshaft pulley clockwise so that timing chain on the timing chain tensioner (primary) side is loose.

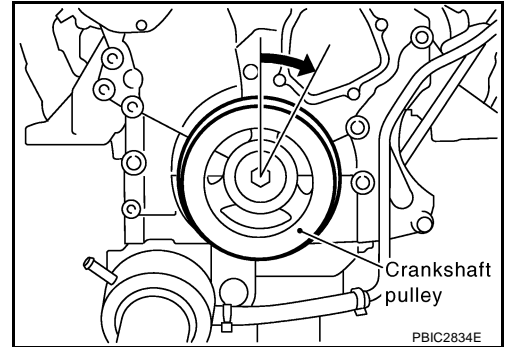

- e. Remove bolts and remove timing chain tensioner (primary).

CAUTION:
Be careful not to drop bolts inside timing chain case.

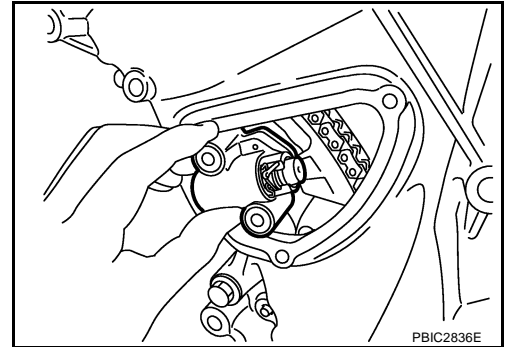

7. Remove water pump as follows:

- a. Remove three water pump bolts. Secure a gap between water pump gear and timing chain, by turning crankshaft pulley counterclockwise until timing chain looseness on water pump sprocket becomes maximum.

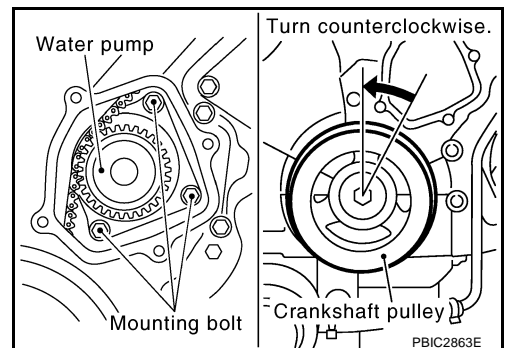

WATER PUMP

- b. Screw M8 bolts [pitch: 1.25 mm (0.049 in) length: approx. 50 mm (1.97 in)] into water pumps upper and lower bolt holes until they reach timing chain case. Then, alternately tighten each bolt for a half turn, and pull out water pump.

CAUTION:

- Pull straight out while preventing vane from contacting socket in installation area.
- Remove water pump without causing sprocket to contact timing chain.

- c. Remove M8 bolts and O-rings from water pump.

CAUTION:

Do not disassemble water pump.

NOTE:

Do not reuse O-rings.

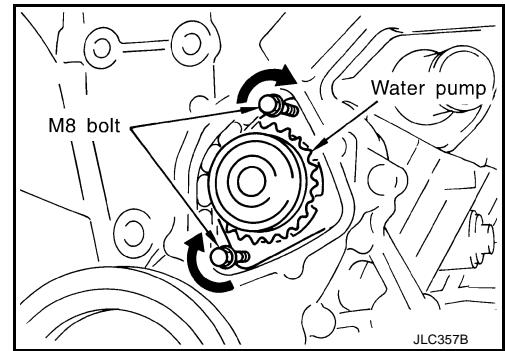

INSPECTION AFTER REMOVAL

- Check for badly rusted or corroded water pump body assembly.
- Check for rough operation due to excessive end play.
- Replace water pump, if necessary.

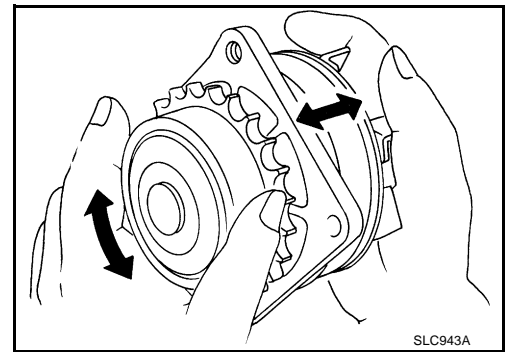

INSTALLATION

1. Install new O-rings to water pump.

NOTE:

- Apply engine oil to O-rings.
- Locate O-ring with white paint mark to engine front side.

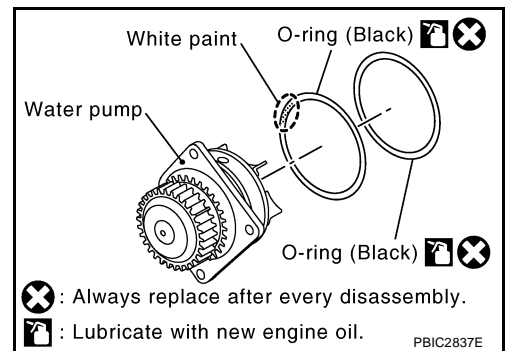

2. Install water pump.

CAUTION:

Do not allow timing chain case to nip O-rings when install water pump.

- Make sure that timing chain and water pump sprocket are engaged.
- Insert water pump by tightening bolts alternately and evenly.

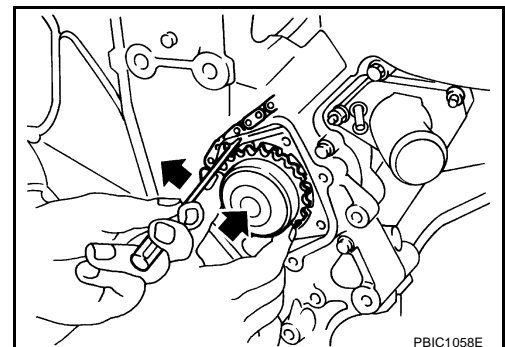

3. Install timing chain tensioner (primary) as follows:

WATER PUMP

- a. Remove dust and foreign material completely from backside of timing chain tensioner (primary) and from installation area of rear timing chain case.
- b. Turn crankshaft pulley clockwise so that timing chain on the timing chain tensioner (primary) side is loose.
- c. Install timing chain tensioner (primary) with its stopper pin attached.

CAUTION:

Be careful not to drop bolts inside timing chain case.

- d. Remove stopper pin.

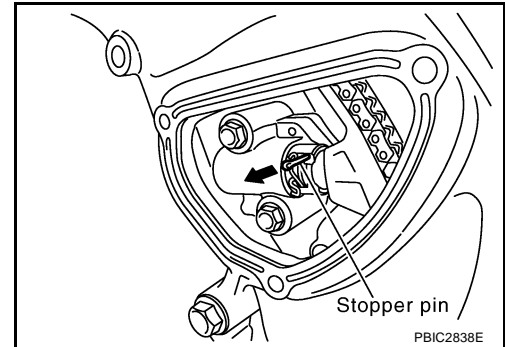

- e. Make sure again that timing chain and water pump sprocket are engaged.
4. Install chain tensioner cover and water pump cover as follows:

- a. Before installing, remove all traces of old liquid gasket from mating surface of water pump cover and chain tensioner cover using scraper. Also remove traces of old liquid gasket from the mating surface of front timing chain case.

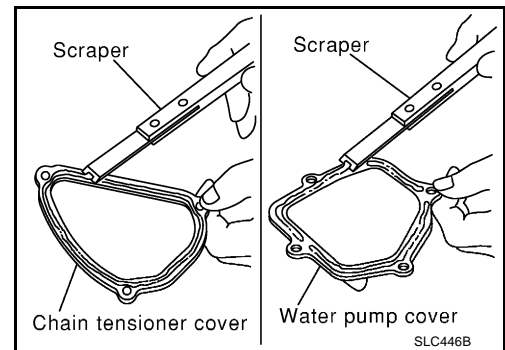

- b. Apply a continuous bead of liquid gasket, to mating surface of chain tensioner and water pump cover, using Tool.

Tool number : WS39930000 (—)

Use Genuine RTV Silicone Sealant or equivalent. Refer to [GI-46, "Recommended Chemical Products and Sealants"](#) .

CAUTION:

Attaching should be done within 5 minutes after coating.

- c. Tighten bolts to specified torque. Refer to [CO-16, "Removal and Installation"](#) .

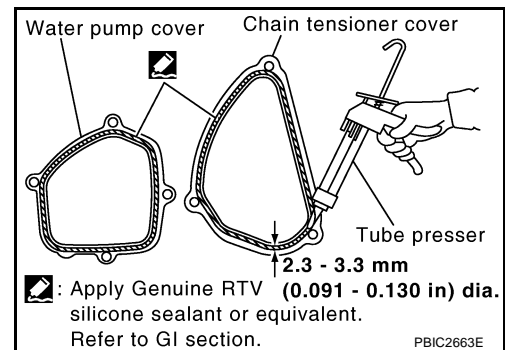

5. Refill engine coolant system. Refer to [MA-14, "REFILLING ENGINE COOLANT"](#) .

- Apply liquid gasket to the thread of water drain plug (front).

Use Genuine RTV Silicone Sealant or equivalent. Refer to [GI-46, "Recommended Chemical Products and Sealants"](#) .

6. Installation of the remaining components is in the reverse order of removal after this step.

- **After starting engine, let idle for three minutes, then rev engine up to 3,000 rpm under no load to purge air from the high-pressure chamber of chain tensioner. Engine may produce a rattling noise. This indicates that air still remains in the chamber and is not a matter of concern.**

INSPECTION AFTER INSTALLATION

- Check for leaks of engine coolant using tool. Refer to [CO-9, "CHECKING COOLING SYSTEM FOR LEAKS"](#) .

WATER PUMP

- Start and warm up engine. Visually check there are no leaks of engine coolant.

WATER INLET AND THERMOSTAT ASSEMBLY

PF2:21200

WATER INLET AND THERMOSTAT ASSEMBLY

Removal and Installation

EBS00NM7

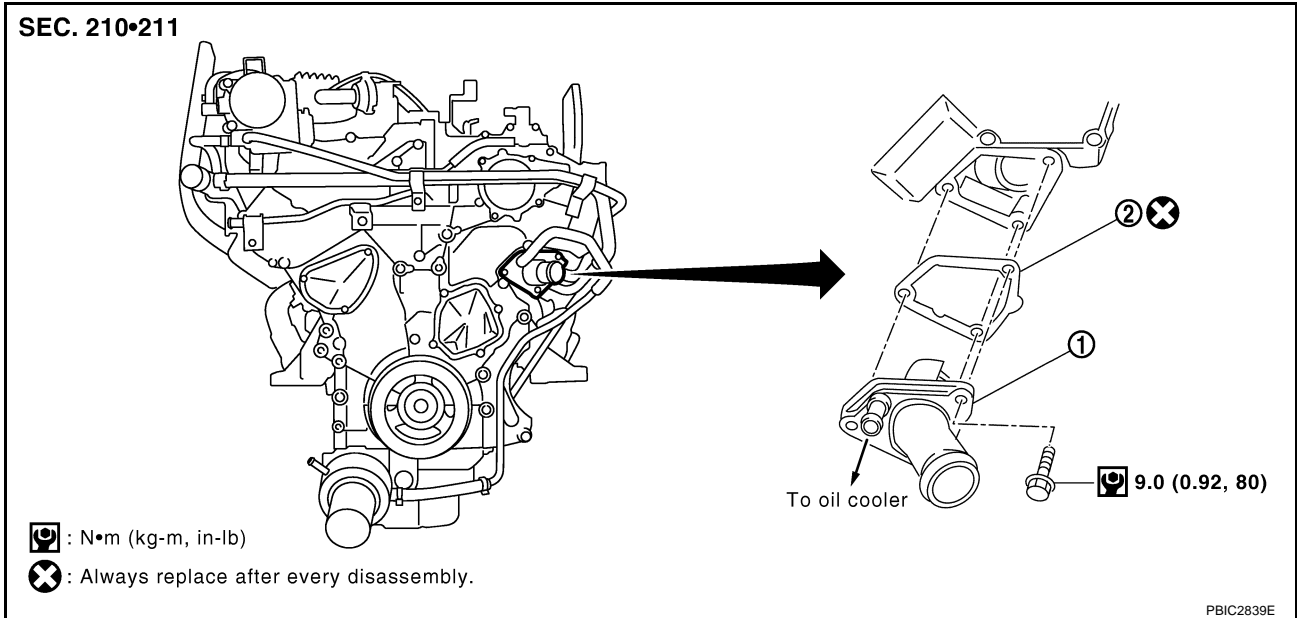

1. Water inlet and thermostat assembly 2. Gasket

REMOVAL

1. Completely drain engine coolant. Refer to [MA-13. "DRAINING ENGINE COOLANT"](#).
- CAUTION:**
 - Perform this step when engine is cold.
 - Do not spill engine coolant on drive belts.
2. Remove air duct and air cleaner case. Refer to [EM-15. "Removal and Installation"](#).
3. Disconnect radiator hose (lower) and oil cooler hose from water inlet and thermostat assembly.
4. Remove water inlet and thermostat assembly.

CAUTION:
 Do not disassemble water inlet and thermostat assembly.
 Replace them as a unit, if necessary.

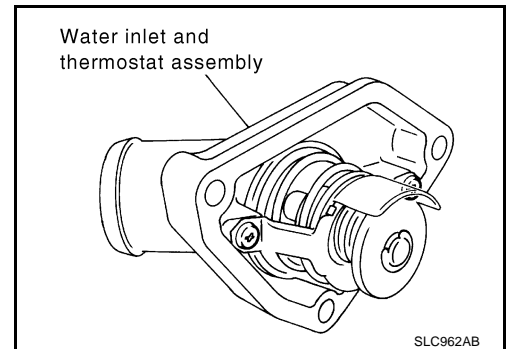

INSPECTION AFTER REMOVAL

1. Check valve seating condition at ordinary room temperatures. It should seat tightly.
2. Check valve operation.

Thermostat	Standard
Valve opening temperature	80.5 - 83.5°C (177 - 182°F)
Maximum valve lift	8.6 mm / 95°C (0.339 in / 203°F)
Valve closing temperature	77°C (171°F)

- If the malfunctioning condition, when valve seating at ordinary room temperature, or measured values are out of the standard, replace water inlet and thermostat assembly.

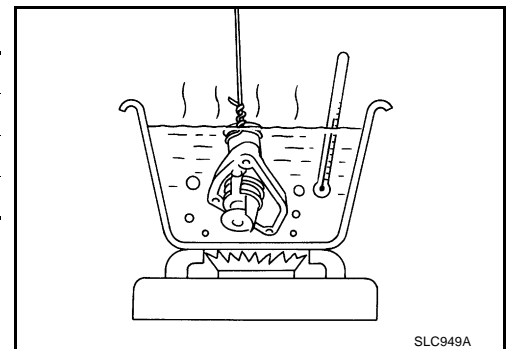

WATER INLET AND THERMOSTAT ASSEMBLY

INSTALLATION

Installation is in the reverse order of removal, paying attention to the following.

- **Be careful not to spill engine coolant over engine room. Use rag to absorb engine coolant.**

INSPECTION AFTER INSTALLATION

- Check for leaks of engine coolant using tool. Refer to [CO-9, "CHECKING COOLING SYSTEM FOR LEAKS"](#) .
- Start and warm up engine. Visually check there are no leaks of engine coolant.

WATER OUTLET AND WATER PIPING

PF11060

EBS00NM8

WATER OUTLET AND WATER PIPING

Removal and Installation

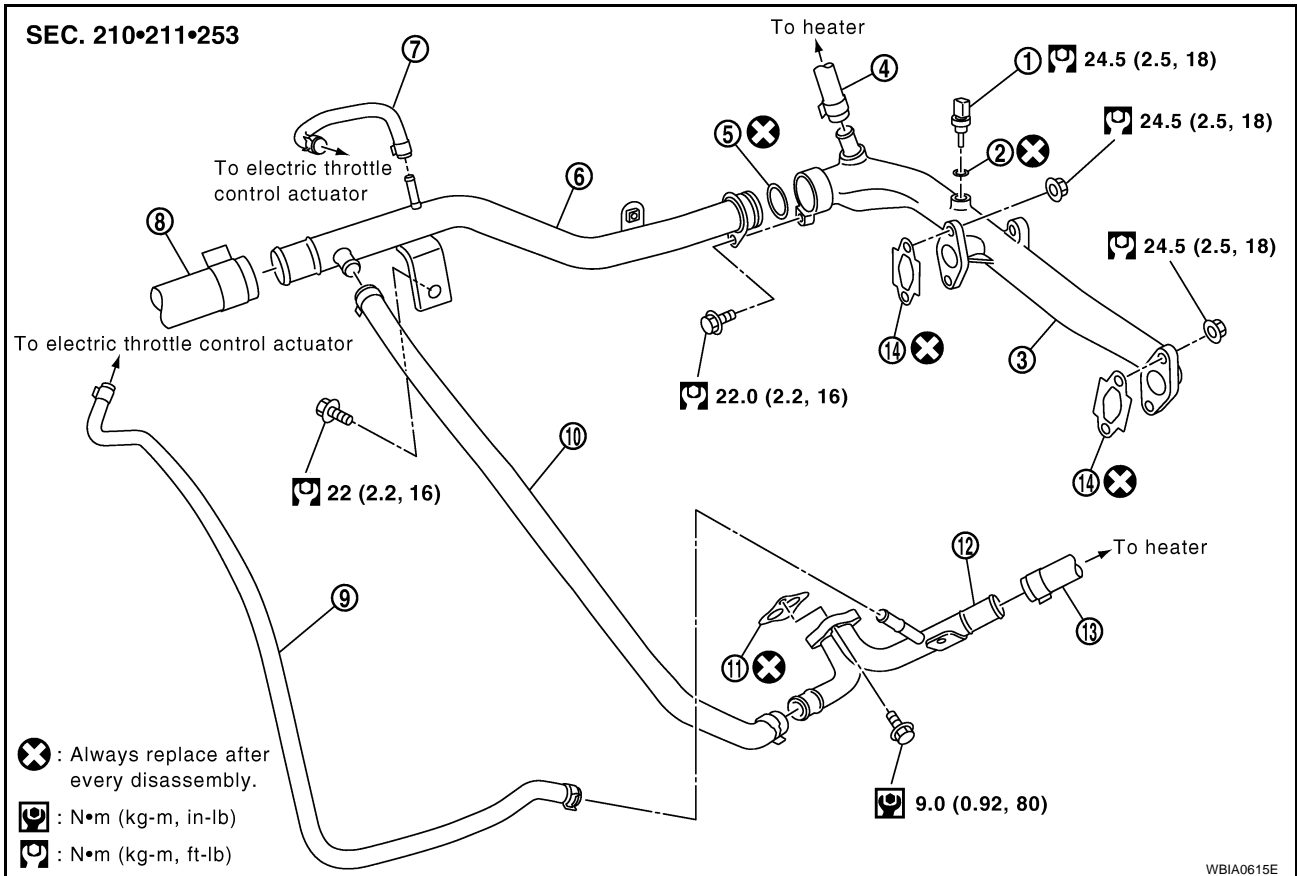

- | | | |
|--------------------------------------|--------------------------|-----------------|
| 1. Engine coolant temperature sensor | 2. Washer | 3. Water outlet |
| 4. Heater hose | 5. O-ring | 6. Water pipe |
| 7. Water hose | 8. Radiator hose (upper) | 9. Water hose |
| 10. Water hose | 11. Gasket | 12. Heater pipe |
| 13. Heater hose | 14. Gasket | |

REMOVAL

1. Completely drain engine coolant. Refer to [MA-13, "DRAINING ENGINE COOLANT"](#).

CAUTION:

- Perform this step when engine is cold.
- Do not spill engine coolant on drive belts.

2. Remove A/T fluid charging pipe Refer to [AT-246, "TRANSMISSION ASSEMBLY"](#).
3. Remove the rocker cover (right bank). Refer to [EM-40, "Removal and Installation"](#).
4. Remove engine coolant temperature sensor as necessary.

CAUTION:

Be careful not to damage engine coolant temperature sensor.

5. Remove water outlet, heater pipe, water bypass hoses and water pipe.

INSTALLATION

Installation is in the reverse order of removal, paying attention to the following.

- Securely insert each hose, and install clamp at a position where it does not interfere with the pipe bulge.
- When inserting water pipe into water outlet, apply neutral detergent to O-ring.

INSPECTION AFTER INSTALLATION

- Check for leaks of engine coolant using tool. Refer to [CO-9, "CHECKING COOLING SYSTEM FOR LEAKS"](#).

WATER OUTLET AND WATER PIPING

- Start and warm up engine. Visually check there are no leaks of engine coolant.

SERVICE DATA AND SPECIFICATIONS (SDS)

SERVICE DATA AND SPECIFICATIONS (SDS)

PFP:00100

Standard and Limit ENGINE COOLANT CAPACITY (APPROXIMATE)

EBS00NM9

Unit: ℓ (US gal, Imp gal)

Engine coolant capacity (With reservoir tank at "MAX" level)	Without rear A/C	10.2 (2-3/4, 2-1/4)
--	------------------	---------------------

RADIATOR

Unit: kPa (kg/cm², psi)

Cap relief pressure	Standard	95 - 125 (0.97 - 1.28, 14 - 18)
	Limit	59 (0.6, 9)
Leakage testing pressure		137 (1.4, 20)

THERMOSTAT

Valve opening temperature	80.5 - 83.5°C (177 - 182°F)
Maximum valve lift	8.6 mm / 95°C (0.339 in / 203°F)
valve closing temperature	77°C (171°F)

A

CO

C

D

E

F

G

H

I

J

K

L

M

SERVICE DATA AND SPECIFICATIONS (SDS)
