

SECTION **SRS**

SUPPLEMENTAL RESTRAINT SYSTEM (SRS)

A
B
C
D
E
F
G
H
I
J
K
L
M

CONTENTS

<p>PRECAUTIONS 3</p> <p> Precautions for Supplemental Restraint System (SRS) "AIR BAG" and "SEAT BELT PRE-TENSIONER" 3</p> <p> Precautions for SRS "AIR BAG" and "SEAT BELT PRE-TENSIONER" Service 3</p> <p> Occupant Classification System Precaution 3</p> <p> Trouble Diagnosis Precaution 3</p> <p>PREPARATION 4</p> <p> Special Service Tools 4</p> <p> Commercial Service Tools 4</p> <p>SUPPLEMENTAL RESTRAINT SYSTEM (SRS) 5</p> <p> SRS Configuration 5</p> <p> Front Seat Belt Pre-tensioner with Load Limiter 6</p> <p> Front Side Air Bag 6</p> <p> Side Curtain Air Bag 6</p> <p> Occupant Classification System 7</p> <p> Direct-connect SRS Component Connectors 7</p> <p>TROUBLE DIAGNOSIS 8</p> <p> Trouble Diagnosis Introduction 8</p> <p> DIAGNOSIS FUNCTION 8</p> <p> HOW TO PERFORM TROUBLE DIAGNOSES FOR QUICK AND ACCURATE REPAIR 8</p> <p> WORK FLOW 9</p> <p> SRS Components Parts Location 10</p> <p> Schematic 11</p> <p> Wiring Diagram — SRS — 12</p> <p> CONSULT-II Function (AIR BAG) 18</p> <p> CONSULT-II Function 18</p> <p> HOW TO CHANGE SELF-DIAGNOSIS MODE WITH CONSULT-II 18</p> <p> HOW TO ERASE SELF-DIAGNOSIS RESULTS.. 19</p> <p> Self-Diagnosis Function (Without CONSULT-II) 19</p> <p> HOW TO CHANGE SELF-DIAGNOSIS MODE.. 19</p> <p> HOW TO ERASE SELF-DIAGNOSIS RESULTS.. 20</p> <p> SRS Operation Check 20</p> <p> DIAGNOSTIC PROCEDURE 1 20</p> <p> Trouble Diagnosis With CONSULT-II 22</p> <p> DIAGNOSTIC PROCEDURE 2 22</p> <p> DIAGNOSTIC PROCEDURE 3 27</p>	<p> DIAGNOSTIC PROCEDURE 4 (CONTINUED FROM DIAGNOSTIC PROCEDURE 2) 29</p> <p> DIAGNOSTIC PROCEDURE 5 29</p> <p> Trouble Diagnosis Without CONSULT-II 35</p> <p> DIAGNOSTIC PROCEDURE 6 35</p> <p> WARNING LAMP FLASH CODE CHART 36</p> <p> Trouble Diagnosis: "AIR BAG" Warning Lamp Does Not Turn Off 40</p> <p> DIAGNOSTIC PROCEDURE 6 40</p> <p> Trouble Diagnosis: "AIR BAG" Warning Lamp Does Not Turn On 41</p> <p> DIAGNOSTIC PROCEDURE 7 41</p> <p>DRIVER AIR BAG MODULE 42</p> <p> Removal and Installation 42</p> <p> REMOVAL 42</p> <p> INSTALLATION 43</p> <p>SPIRAL CABLE 44</p> <p> Removal and Installation 44</p> <p> REMOVAL 44</p> <p> INSTALLATION 45</p> <p>FRONT PASSENGER AIR BAG MODULE 46</p> <p> Removal and Installation 46</p> <p> REMOVAL 46</p> <p> INSTALLATION 47</p> <p> WIRING HARNESS MODIFICATION 48</p> <p>SIDE CURTAIN AIR BAG MODULE 50</p> <p> Removal and Installation 50</p> <p> REMOVAL 50</p> <p> INSTALLATION 50</p> <p>CRASH ZONE SENSOR 52</p> <p> Removal and Installation 52</p> <p> REMOVAL 52</p> <p> INSTALLATION 52</p> <p>SIDE AIR BAG (SATELLITE) SENSOR 53</p> <p> Removal and Installation 53</p> <p> REMOVAL 53</p> <p> INSTALLATION 53</p> <p>FRONT SEAT BELT PRE-TENSIONER 54</p> <p> Removal and Installation 54</p>
---	--

SRS

DIAGNOSIS SENSOR UNIT	55	For Side Collision	58
Removal and Installation	55	WHEN SRS IS ACTIVATED IN THE SIDE COL-	
REMOVAL	55	LISION	58
INSTALLATION	55	WHEN SRS IS NOT ACTIVATED IN THE SIDE	
ECU DISCRIMINATED NO.	55	COLLISION	58
OCCUPANT CLASSIFICATION SYSTEM CON-		SRS INSPECTION (FOR SIDE COLLISION)	58
TROL UNIT	56	For Rollover	59
Removal and Installation	56	WHEN SRS IS ACTIVATED IN THE ROLLOVER..	59
COLLISION DIAGNOSIS	57	WHEN SRS IS NOT ACTIVATED IN THE ROLL-	
For Frontal Collision	57	OVER	59
SRS INSPECTION (FOR FRONTAL COLLI-		SRS INSPECTION (FOR ROLLOVER)	60
SION)	57		

PRECAUTIONS

PRECAUTIONS

PFP:00001

Precautions for Supplemental Restraint System (SRS) “AIR BAG” and “SEAT BELT PRE-TENSIONER”

EHS001DP

The Supplemental Restraint System such as “AIR BAG” and “SEAT BELT PRE-TENSIONER”, used along with a front seat belt, helps to reduce the risk or severity of injury to the driver and front passenger for certain types of collision. This system includes seat belt switch inputs and dual stage front air bag modules. The SRS system uses the seat belt switches to determine the front air bag deployment, and may only deploy one front air bag, depending on the severity of a collision and whether the front occupants are belted or unbelted. Information necessary to service the system safely is included in the SRS and SB section of this Service Manual.

WARNING:

- To avoid rendering the SRS inoperative, which could increase the risk of personal injury or death in the event of a collision which would result in air bag inflation, all maintenance must be performed by an authorized NISSAN/INFINITI dealer.
- Improper maintenance, including incorrect removal and installation of the SRS, can lead to personal injury caused by unintentional activation of the system. For removal of Spiral Cable and Air Bag Module, see the SRS section.
- Do not use electrical test equipment on any circuit related to the SRS unless instructed to in this Service Manual. SRS wiring harnesses can be identified by yellow and/or orange harnesses or harness connectors.

Precautions for SRS “AIR BAG” and “SEAT BELT PRE-TENSIONER” Service

EHS001DQ

- Do not use electrical test equipment to check SRS circuits unless instructed to in this Service Manual.
- Before servicing the SRS, turn ignition switch OFF, disconnect both battery cables and wait at least 3 minutes.
For approximately 3 minutes after the cables are removed, it is still possible for the air bag and seat belt pre-tensioner to deploy. Therefore, do not work on any SRS connectors or wires until at least 3 minutes have passed.
- The air bag diagnosis sensor unit must always be installed with the arrow mark “←” pointing toward the front of the vehicle for proper operation. Also check the air bag diagnosis sensor unit for cracks, deformities or rust before installation and replace as required.
- The spiral cable must be aligned with the neutral position since its rotations are limited. Do not attempt to turn steering wheel or column after removal of steering gear.
- Handle air bag module carefully. Always place driver and front passenger air bag modules with the pad side facing upward and seat mounted front side air bag module standing with the stud bolt side facing down.
- Conduct self-diagnosis to check entire SRS for proper function after replacing any components.
- After air bag inflates, the front instrument panel assembly should be replaced if damaged.

SRS

Occupant Classification System Precaution

EHS001G2

Replace control unit and passenger front seat cushion as an assembly.

Trouble Diagnosis Precaution

EHS001DS

When you read wiring diagrams, refer to the following:

- [GI-16, "How to Read Wiring Diagrams"](#) in GI section
- [PG-4, "POWER SUPPLY ROUTING CIRCUIT"](#) in PG section

When you perform trouble diagnosis, refer to the following:

- [GI-12, "HOW TO FOLLOW TEST GROUPS IN TROUBLE DIAGNOSES"](#) in GI section
- [GI-28, "How to Perform Efficient Diagnosis for an Electrical Incident"](#) in GI section

Check for any service bulletins before servicing the vehicle.

PREPARATION

PREPARATION

PFP:00002

Special Service Tools

EHS001DT

The actual shapes of Kent-Moore tools may differ from those of special service tools illustrated here.

Tool number (Kent-Moore No.) Tool name	Description
— (J-42057-UPD) Air bag key set Part of kit (J-42057)	Removing and installing air bag lock

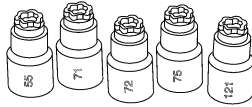

LRS210

Commercial Service Tools

EHS001DU

(Kent-Moore No.) Tool name	Description
(J-1859A) Steering wheel puller	Removing steering wheel
(J-42578) Steering wheel puller legs	Removing steering wheel

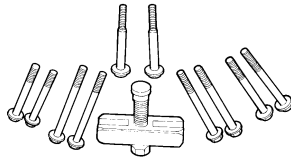

LHIA0043E

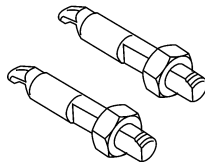

LHIA0044E

SUPPLEMENTAL RESTRAINT SYSTEM (SRS)

SUPPLEMENTAL RESTRAINT SYSTEM (SRS)

PF2:28556

SRS Configuration

EHS001G3

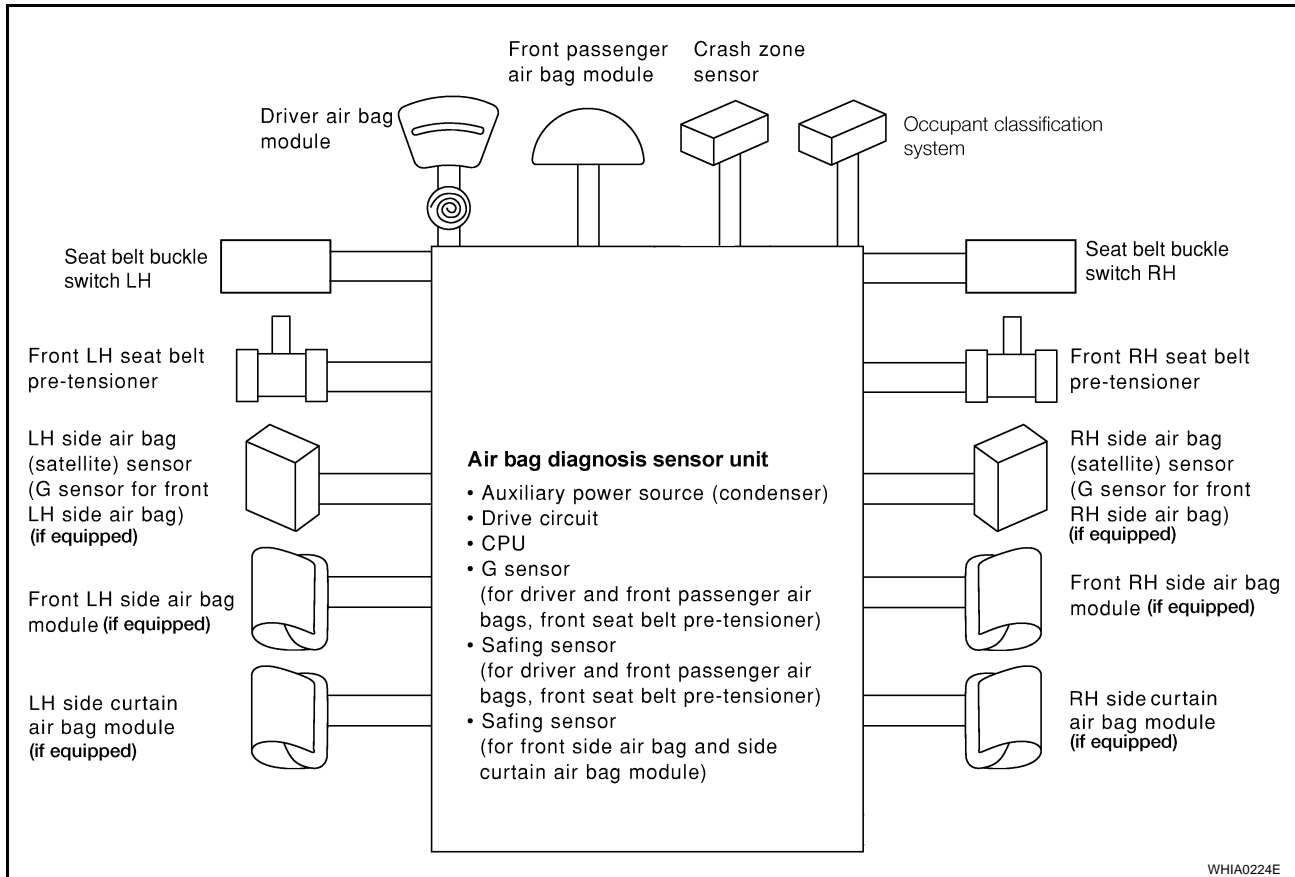

The air bag deploys if the air bag diagnosis sensor unit is activated while the ignition switch is in the ON or START position. The collision modes for which supplemental restraint systems are activated are different among the SRS systems. For example, the driver air bag module, front passenger air bag module and front seat belt pre-tensioners are activated in a frontal collision but not in a side collision.

SRS configurations for some collision modes are as follows:

SRS configuration	Frontal collision	Left side collision	Right side collision	Rollover
Driver air bag module	x	—	—	—
Front passenger air bag module	x	—	—	—
Front LH seat belt pre-tensioner	x	—	—	x
Front RH seat belt pre-tensioner	x	—	—	x
Front LH side air bag module	—	x	—	—
Front RH side air bag module	—	—	x	—
LH side curtain air bag module	—	x	—	x
RH side curtain air bag module	—	—	x	x

SUPPLEMENTAL RESTRAINT SYSTEM (SRS)

Front Seat Belt Pre-tensioner with Load Limiter

EHS001G4

The seat belt pre-tensioner system with load limiter is installed for both the driver's seat and the front passenger's seat. It operates simultaneously with the SRS air bag system in the event of a frontal collision with an impact exceeding a specified level.

When the frontal collision with an impact exceeding a specified level occurs, seat belt slack resulting from clothing or other factors is immediately taken up by the pre-tensioner. Vehicle passengers are securely restrained.

When passengers in a vehicle are thrown forward in a collision and the restraining force of the seat belt exceeds a specified level, the load limiter permits the specified extension of the seat belt by the twisting of the ELR shaft, and a relaxation of the chest-area seat belt web tension while maintaining force.

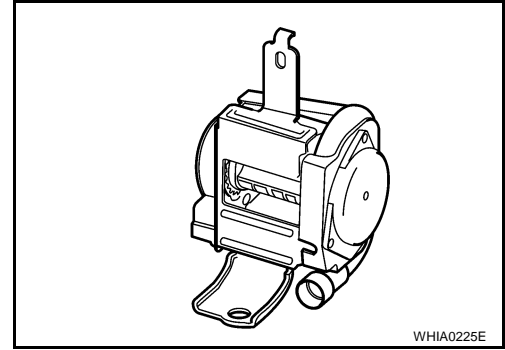

WHIA0225E

Front Side Air Bag

EHS001G5

Front side air bag modules are built into the front seatback assemblies. Vehicles with side air bags are equipped with labels as shown.

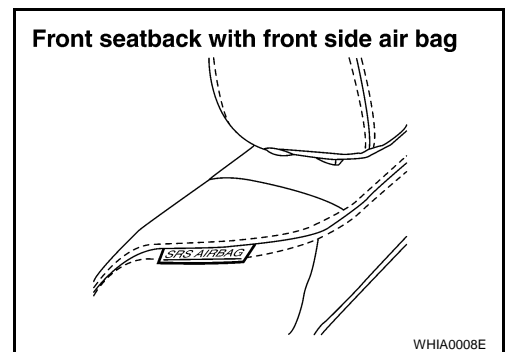

WHIA0008E

Side Curtain Air Bag

EHS001G6

Side curtain air bag modules are located above the vehicle headlining. Vehicles with side curtain air bags are equipped with labels as shown.



WHIA0041E

SUPPLEMENTAL RESTRAINT SYSTEM (SRS)

EHS001G7

Occupant Classification System

The occupant classification system identifies different size occupants, out of position occupants, and detects if child seat is present in the front passenger seat. The occupant classification system receives inputs from the occupant classification system sensor (located inside the passenger seat cushion assembly) and belt tension sensor (part of the passenger front seat belt assembly and located at the belt anchor location). Depending on classification of passenger, the occupant classification system sends a signal to the air bag diagnosis sensor unit. The air bag diagnosis sensor unit uses this signal to determine deployment or non deployment of the passenger front air bag in the event of a collision. Depending on the signal received, the air bag diagnosis sensor unit can disable the passenger front air bag completely. If this occurs the air bag diagnosis sensor unit will turn on the PASS AIR BAG OFF indicator.

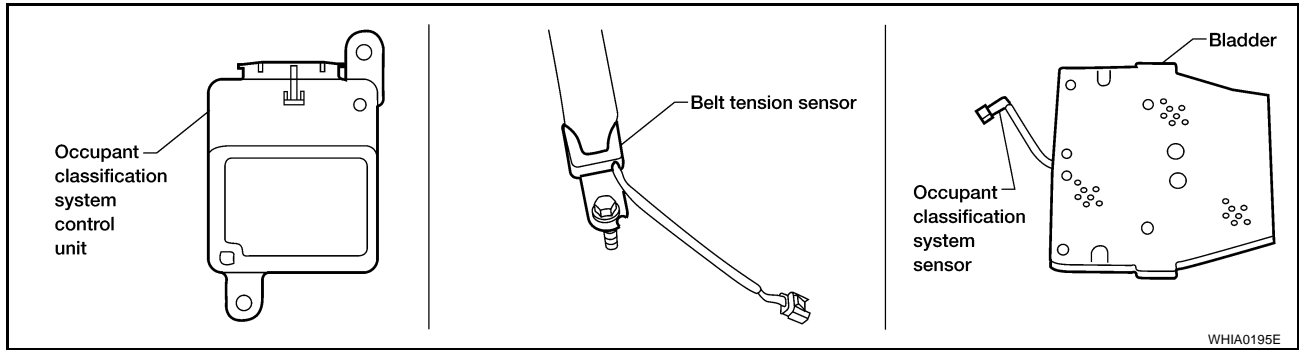

Direct-connect SRS Component Connectors

EHS001G8

The following SRS components use direct-connect style harness connectors.

- Driver air bag module
- Front passenger air bag module
- LH side curtain air bag module
- RH side curtain air bag module
- Front LH seat belt pre-tensioner
- Front RH seat belt pre-tensioner

Always pull up to release black locking tab prior to removing connector from SRS component.

Always push down to lock black locking tab after installing connector to SRS component. When locked, the black locking tab is level with the connector housing.

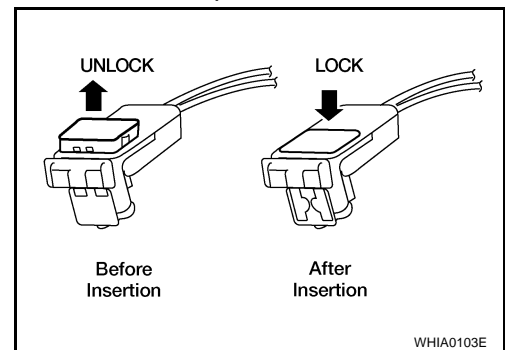

A
B
C
D
E
F
G
I
J
K
L
M

SRS

TROUBLE DIAGNOSIS

TROUBLE DIAGNOSIS

PFP:00004

Trouble Diagnosis Introduction

EHS001G9

CAUTION:

- Do not use electrical test equipment on any circuit related to the SRS unless instructed to do so in this Service Manual. SRS wiring harnesses can be identified by yellow and/or orange harness connectors.
- Do not attempt to repair, splice or modify SRS wiring harnesses. If a harness is damaged, replace it with a new one.
- Keep ground connections clean.

DIAGNOSIS FUNCTION

The SRS self-diagnosis results can be read by using "AIR BAG" warning lamp and/or CONSULT-II.

The User mode is exclusively prepared for the customer (driver). This mode warns the driver of a system malfunction through the operation of the "AIR BAG" warning lamp.

The Diagnosis mode allows the technician to locate and inspect the malfunctioning part.

The mode applications for the "AIR BAG" warning lamp and CONSULT-II are as follows:

	User mode	Diagnosis mode	Display type
"AIR BAG" warning lamp	X	X	ON-OFF operation
CONSULT-II	—	X	Monitoring

HOW TO PERFORM TROUBLE DIAGNOSES FOR QUICK AND ACCURATE REPAIR

A good understanding of the malfunction conditions can make troubleshooting faster and more accurate.

In general, each customer feels differently about a malfunction. It is important to fully understand the symptoms or conditions for a customer complaint.

Information From Customer

WHAT - Vehicle model

WHEN - Date, Frequencies

WHERE - Road conditions

HOW - Operating conditions, Symptoms

Preliminary Check

Check that the following parts are in good order.

- Battery (Refer to [SC-4, "How to Handle Battery"](#) .)
- Fuse (Refer to [SRS-12, "Wiring Diagram — SRS —"](#) .)
- System component-to-harness connections

TROUBLE DIAGNOSIS

WORK FLOW

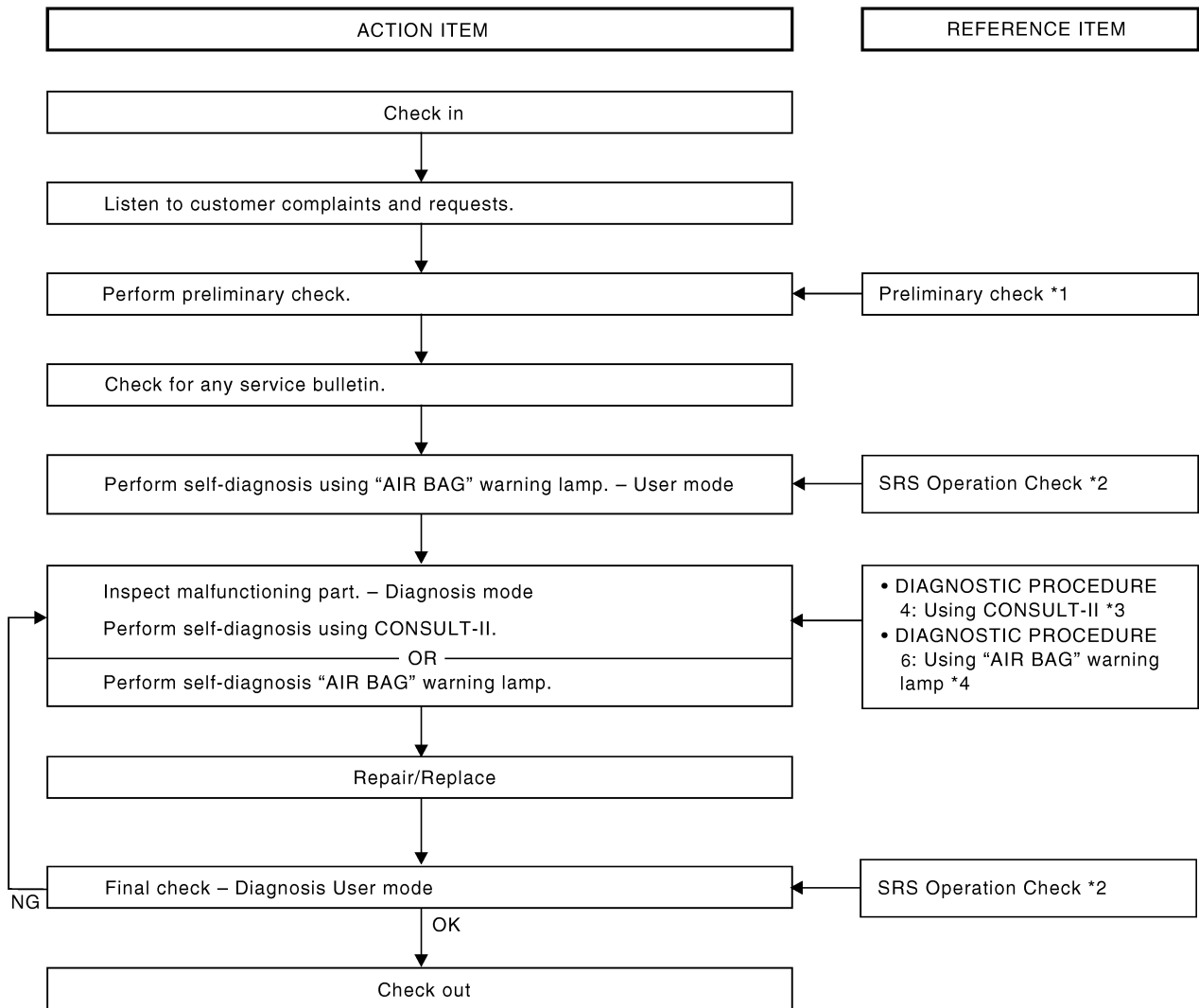

*1: [SRS-8](#)

*2: [SRS-20](#)

*3: [SRS-29](#)

*4: [SRS-35](#)

WHIA0098E

A
B
C
D
E
F
G
SRS
I
J
K
L
M

TROUBLE DIAGNOSIS

SRS Components Parts Location

EHS001GA

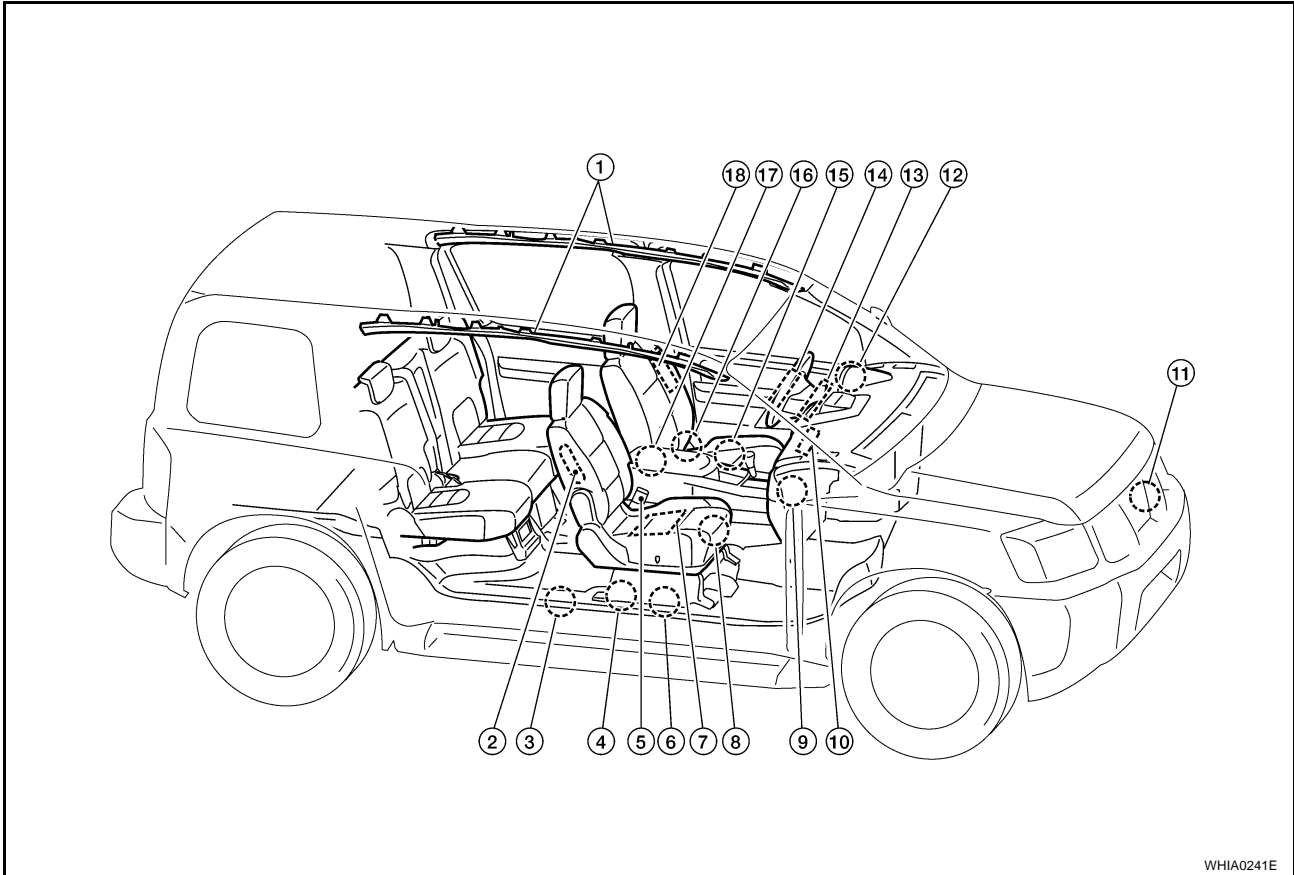

WHIA0241E

- | | | |
|---|--|--|
| 1. Side curtain air bag modules (If equipped) | 2. Front RH side air bag module (If equipped) | 3. Front RH seat belt pre-tensioner |
| 4. Belt tension sensor | 5. Seat belt buckle switch RH | 6. RH side air bag (satellite) sensor (If equipped) |
| 7. Occupant classification system sensor | 8. Occupant classification system control unit | 9. Front passenger air bag off indicator |
| 10. Front passenger air bag module | 11. Crash zone sensor | 12. Air bag warning lamp |
| 13. Spiral cable | 14. Driver air bag module | 15. LH side air bag (satellite) sensor (If equipped) |
| 16. Front LH seat belt pre-tensioner | 17. Air bag diagnosis sensor unit | 18. Front LH side air bag module (If equipped) |

TROUBLE DIAGNOSIS

Wiring Diagram — SRS —

EHS001GC

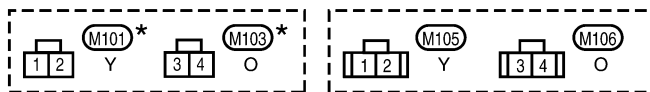
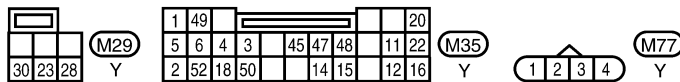
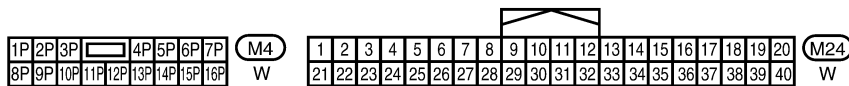
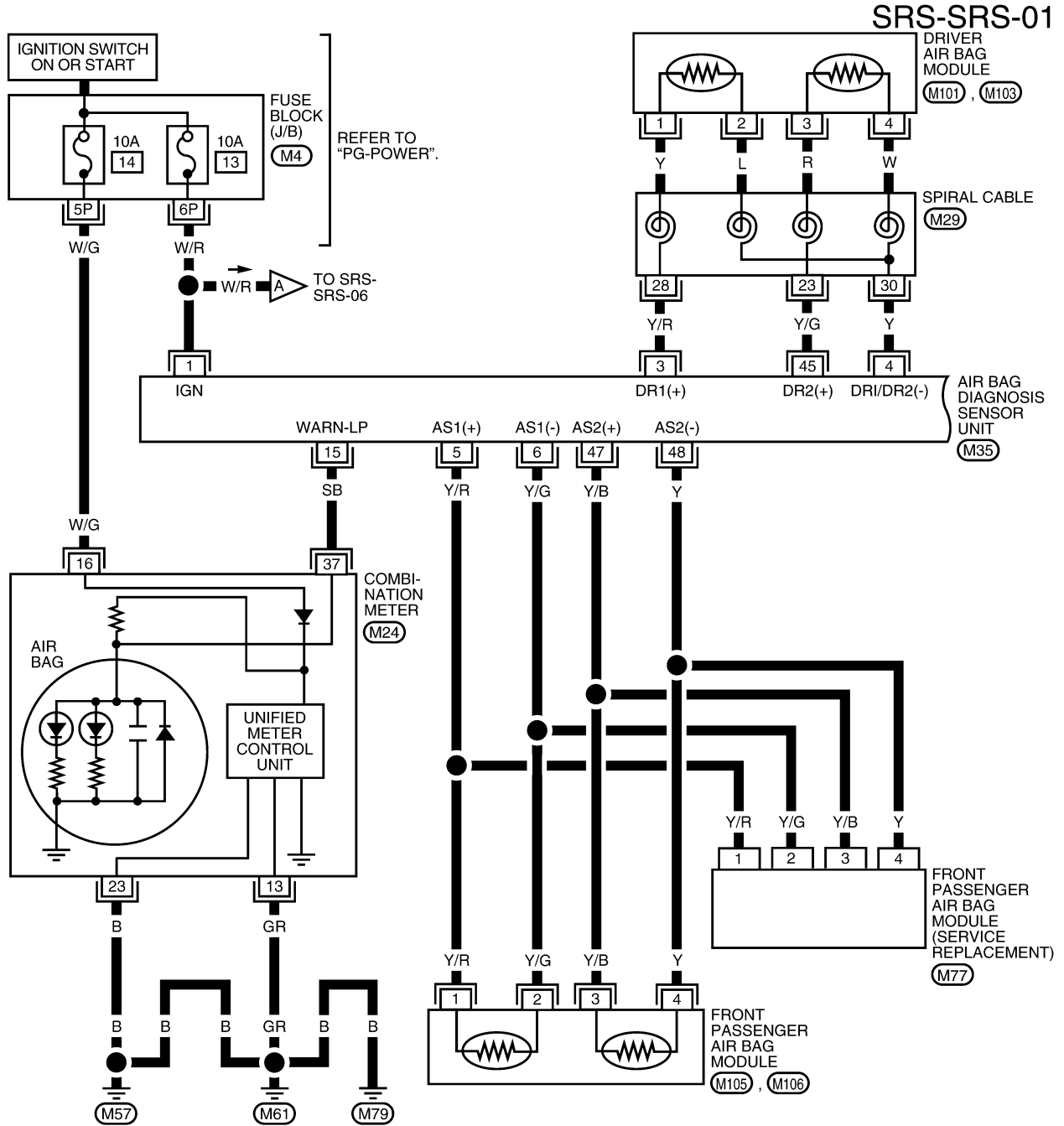

*: THIS CONNECTOR IS NOT SHOWN IN "HARNESS LAYOUT" OF PG SECTION.

WHWA0149E

TROUBLE DIAGNOSIS

SRS-SRS-02

A
B
C
D
E
F
G
H
I
J
K
L
M

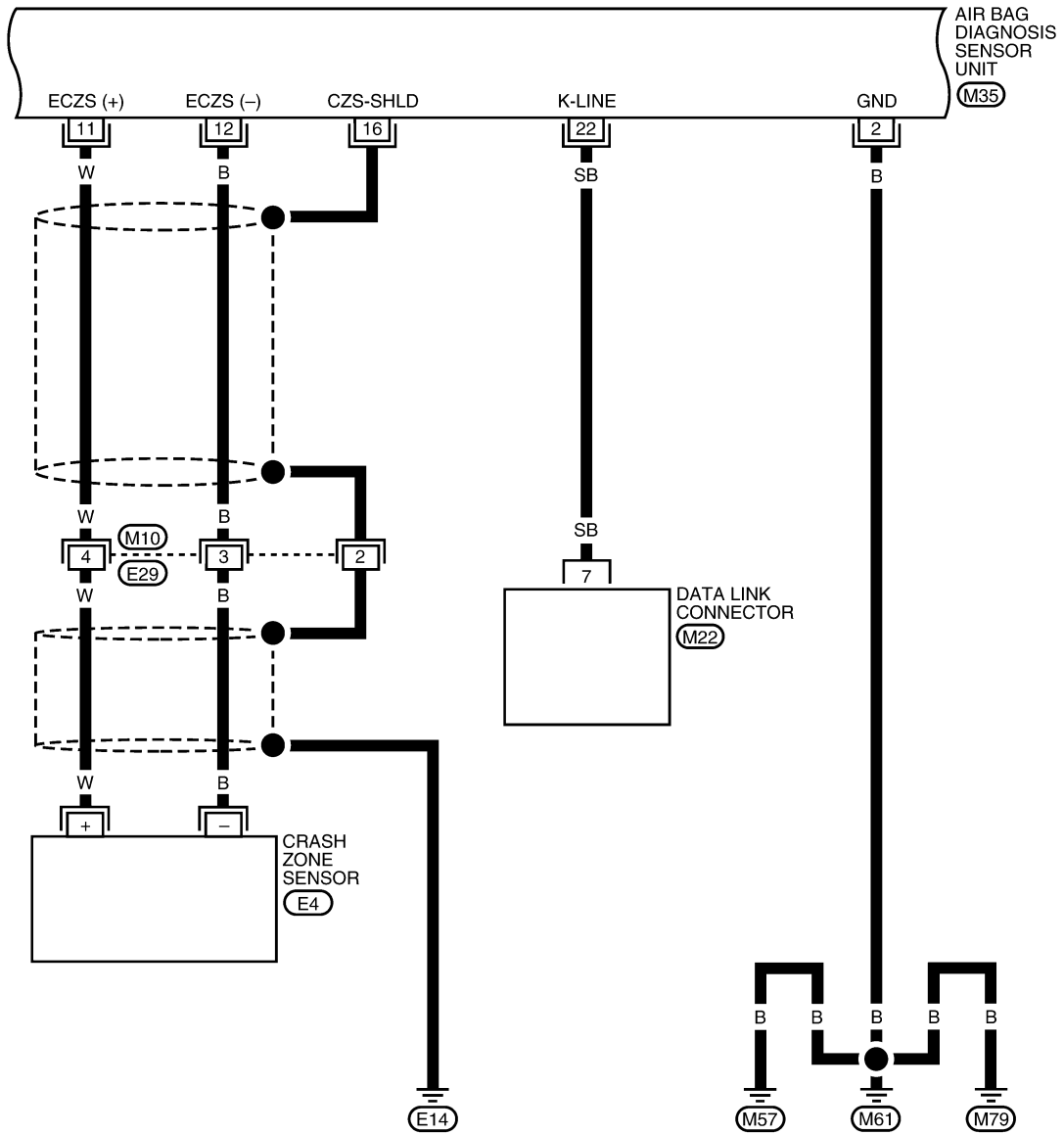

SRS

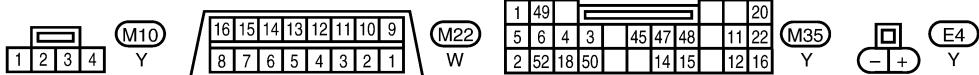

WHWA0150E

TROUBLE DIAGNOSIS

SRS-SRS-03

 : WITH SIDE AIR BAGS

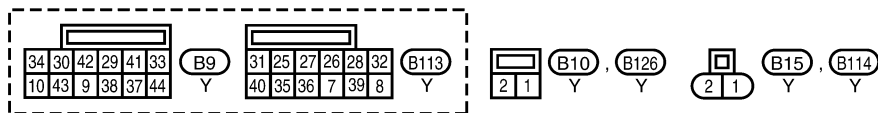
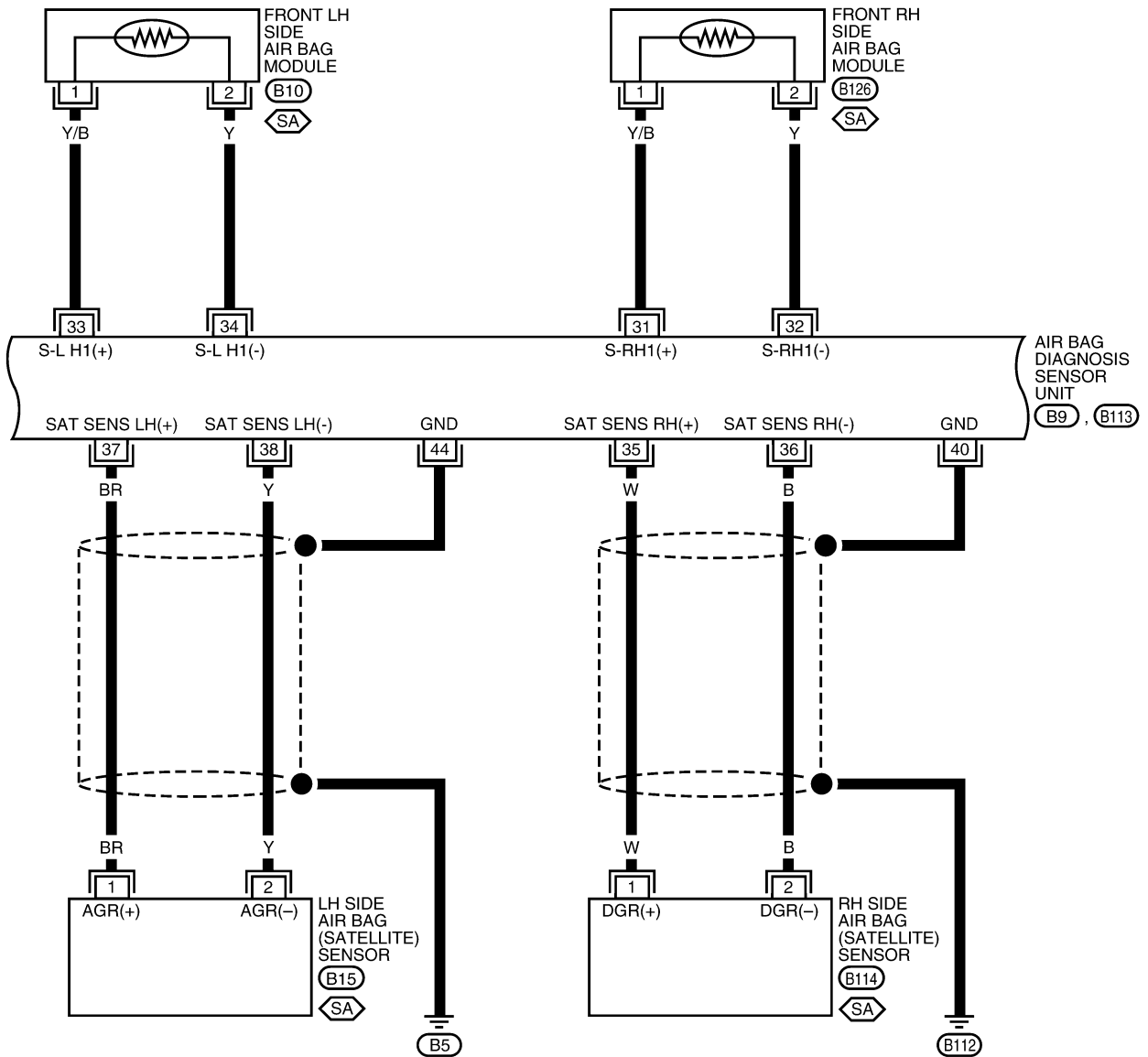

WHWA0151E

TROUBLE DIAGNOSIS

SRS-SRS-04

◊SA◊ : WITH SIDE AIR BAGS

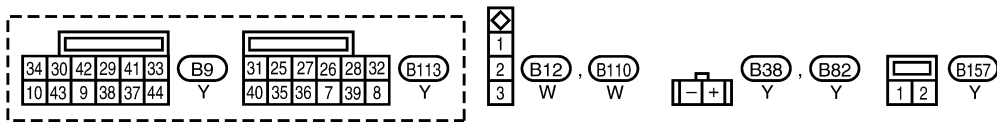
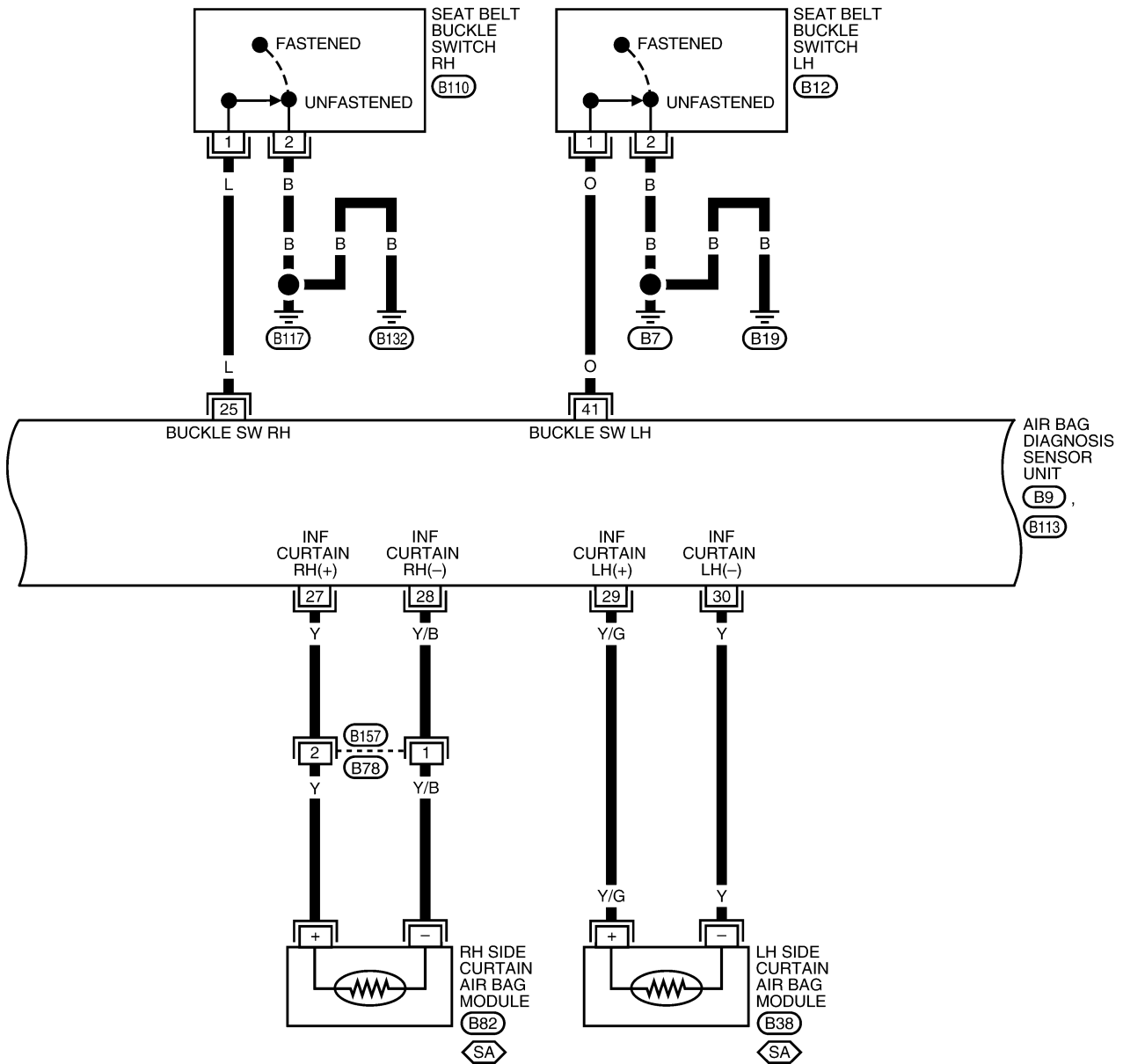

WHWA0152E

TROUBLE DIAGNOSIS

SRS-SRS-05

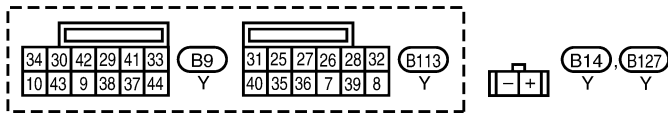
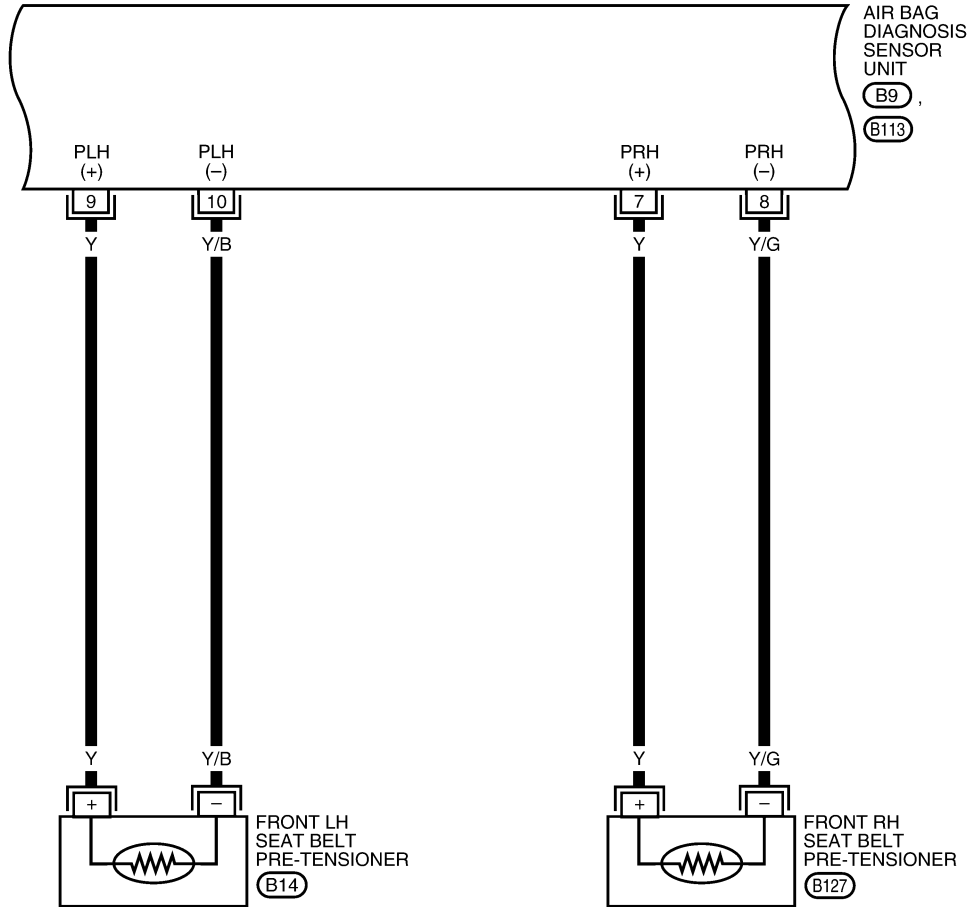

WHWA0153E

TROUBLE DIAGNOSIS

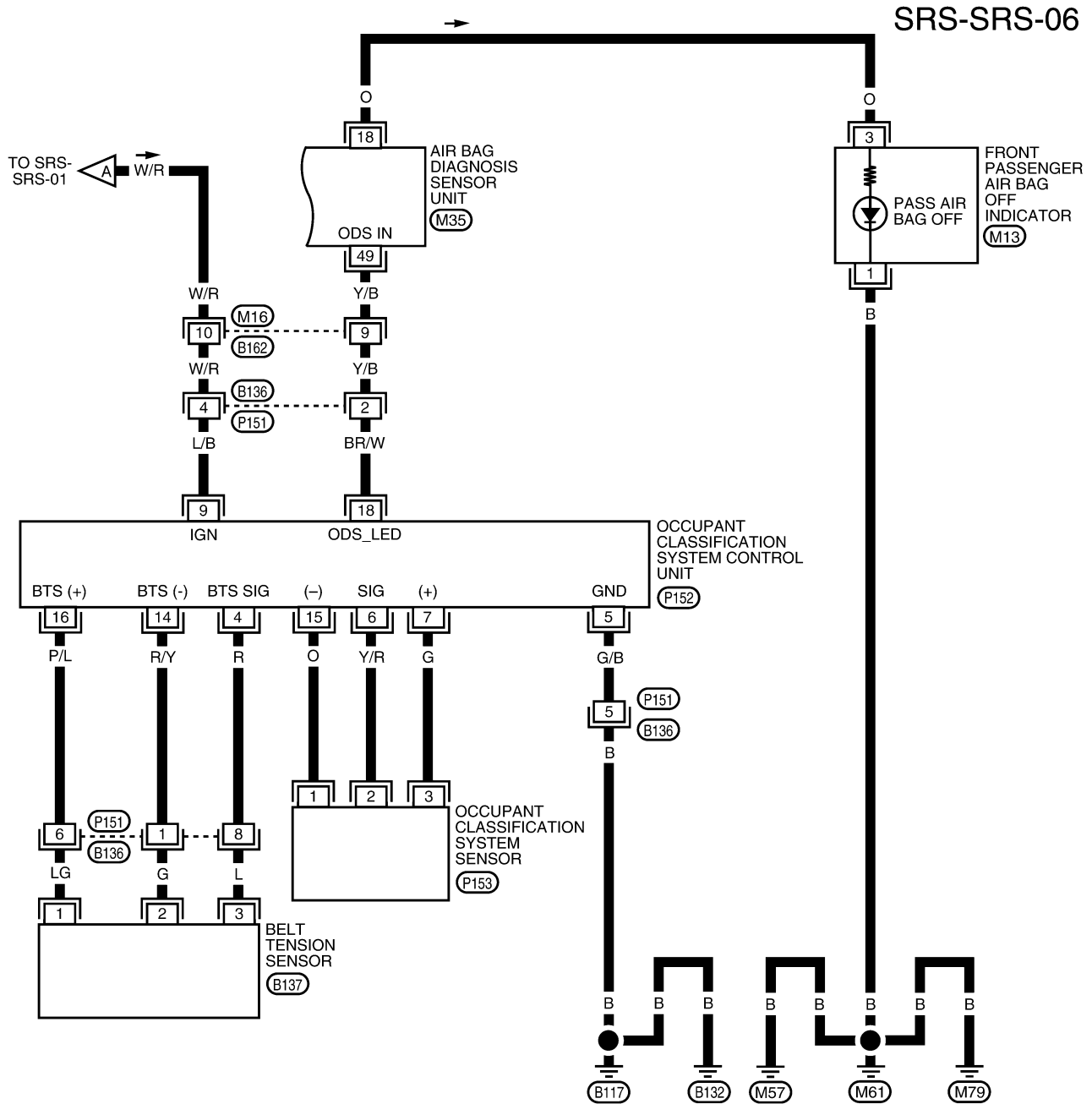

A
B
C
D
E
F
G
SRS
I
J
K
L
M

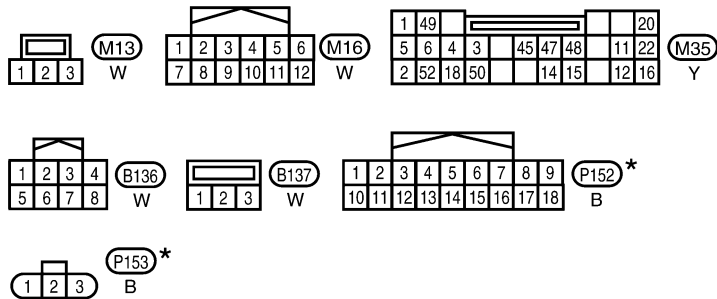

*: THIS CONNECTOR IS NOT SHOWN IN "HARNESS LAYOUT" OF PG SECTION.

WHWA0154E

TROUBLE DIAGNOSIS

CONSULT-II Function (AIR BAG)

EHS001GD

CONSULT-II can display each diagnostic item using the diagnostic test modes shown following.

AIR BAG diagnostic mode	Description												
SELF-DIAG [CURRENT]	A current Self-diagnosis result (also indicated by the number of warning lamp flashes in the Diagnosis mode) is displayed on the CONSULT-II screen in real time. This refers to a malfunctioning part requiring repairs.												
SELF-DIAG [PAST]	Diagnosis results previously stored in the memory are displayed on the CONSULT-II screen. The stored results will remain until memory erasing is executed.												
TROUBLE DIAG RECORD	With TROUBLE DIAG RECORD, diagnosis results previously erased by a reset operation can be displayed on the CONSULT-II screen.												
ECU DISCRIMINATED NO.	<p>The air bag diagnosis sensor unit for each vehicle model is assigned with its own, individual classification number. This number will be displayed on the CONSULT-II screen, as shown. When replacing the air bag diagnosis sensor unit, refer to the part number for the compatibility. After installation, replacement with a correct unit can be checked by confirming this classification number on the CONSULT-II screen.</p> <p>For NISSAN MODEL N50, the air bag diagnosis sensor unit discriminated numbers assigned are FA04 (for models with side and side curtain air bags) and FA08 (for models without side and side curtain air bags).</p> <div style="border: 1px solid black; padding: 5px; width: fit-content; margin-left: auto; margin-right: auto;"> <table style="width: 100%; border-collapse: collapse;"> <tr> <td colspan="3" style="text-align: center; padding: 5px;">ECU DISCRIMINATED NO.</td> </tr> <tr> <td colspan="3" style="text-align: center; padding: 5px;">ECU No. XXXX</td> </tr> <tr> <td colspan="3" style="text-align: center; padding: 5px;">PRINT</td> </tr> <tr> <td style="text-align: center; padding: 5px;">BACK</td> <td style="text-align: center; padding: 5px;">LIGHT</td> <td style="text-align: center; padding: 5px;">COPY</td> </tr> </table> <p style="text-align: right; margin-top: 0;">ARS366</p> </div>	ECU DISCRIMINATED NO.			ECU No. XXXX			PRINT			BACK	LIGHT	COPY
ECU DISCRIMINATED NO.													
ECU No. XXXX													
PRINT													
BACK	LIGHT	COPY											

CONSULT-II Function

EHS001GE

Ⓟ HOW TO CHANGE SELF-DIAGNOSIS MODE WITH CONSULT-II

From User Mode to Diagnosis Mode

After selecting "AIR BAG" on the "SELECT SYSTEM" screen, User mode automatically changes to Diagnosis mode.

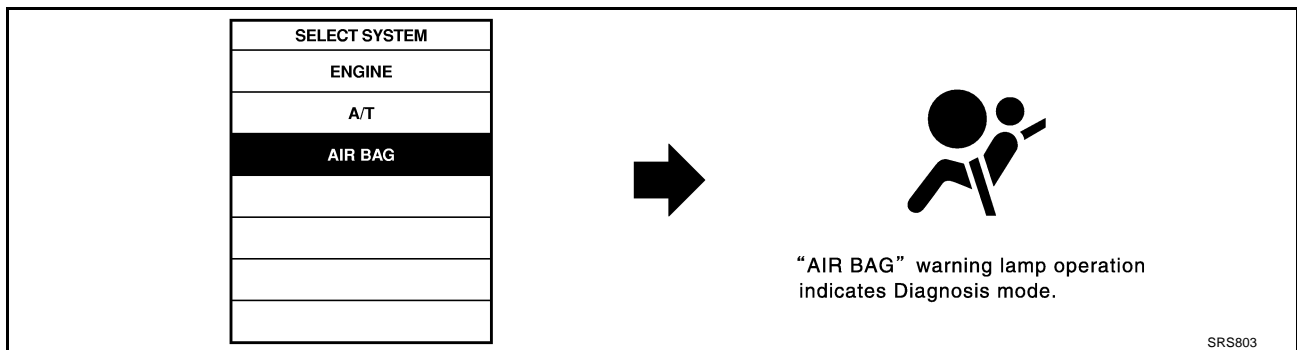

From Diagnosis Mode to User Mode

To return to User mode from Diagnosis mode, touch "BACK" key of CONSULT-II until "SELECT SYSTEM" appears, Diagnosis mode automatically changes to User mode.

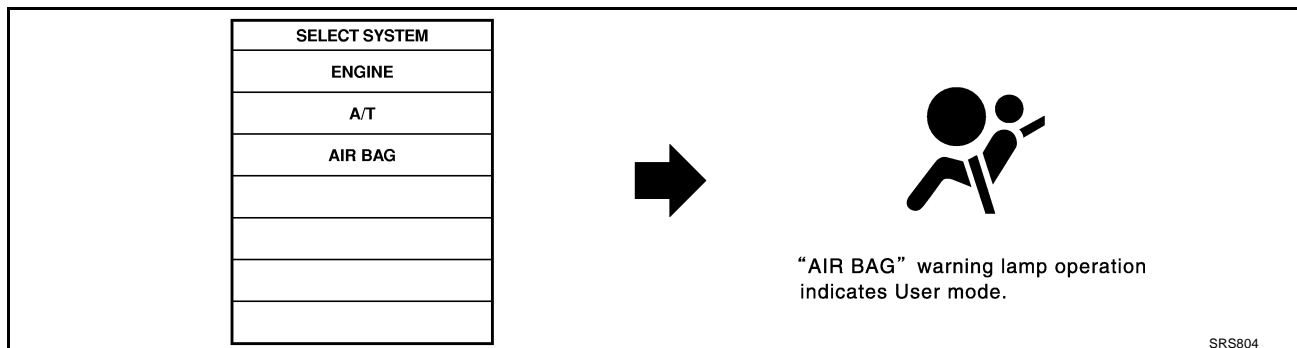

TROUBLE DIAGNOSIS

HOW TO ERASE SELF-DIAGNOSIS RESULTS

- “SELF-DIAG [CURRENT]”

A current self-diagnosis result is displayed on the CONSULT-II screen in real time. After the malfunction is repaired completely, no malfunction is detected on “SELF-DIAG [CURRENT]”.

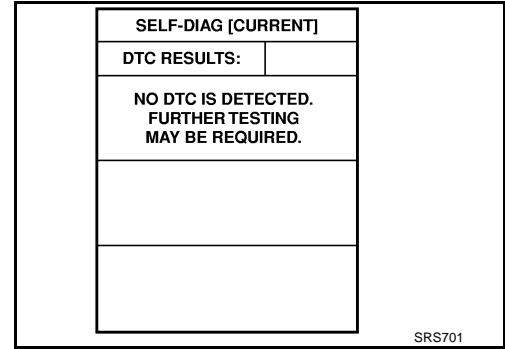

- “SELF-DIAG [PAST]”

Return to the “SELF-DIAG [CURRENT]” CONSULT-II screen by touching “BACK” key of CONSULT-II and select “SELF-DIAG [PAST]” in SELECT DIAG MODE. Touch “ERASE” in “SELF-DIAG [PAST]” mode.

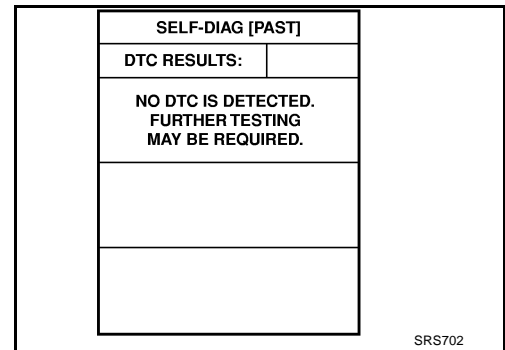

NOTE:

If the memory of the malfunction in “SELF-DIAG [PAST]” is not erased, the User mode will continue to show the system malfunction by the operation of the warning lamp even if the malfunction is repaired completely.

- “TROUBLE DIAG RECORD”

The memory of “TROUBLE DIAG RECORD” cannot be erased.

Self-Diagnosis Function (Without CONSULT-II)

EHS001GF

- The reading of these results is accomplished using one of two modes — “User mode” and “Diagnosis mode”.
- After a malfunction is repaired, turn the ignition switch OFF for at least one second, then back ON. Diagnosis mode returns to the User mode. At that time, the self-diagnostic result is cleared.

HOW TO CHANGE SELF-DIAGNOSIS MODE

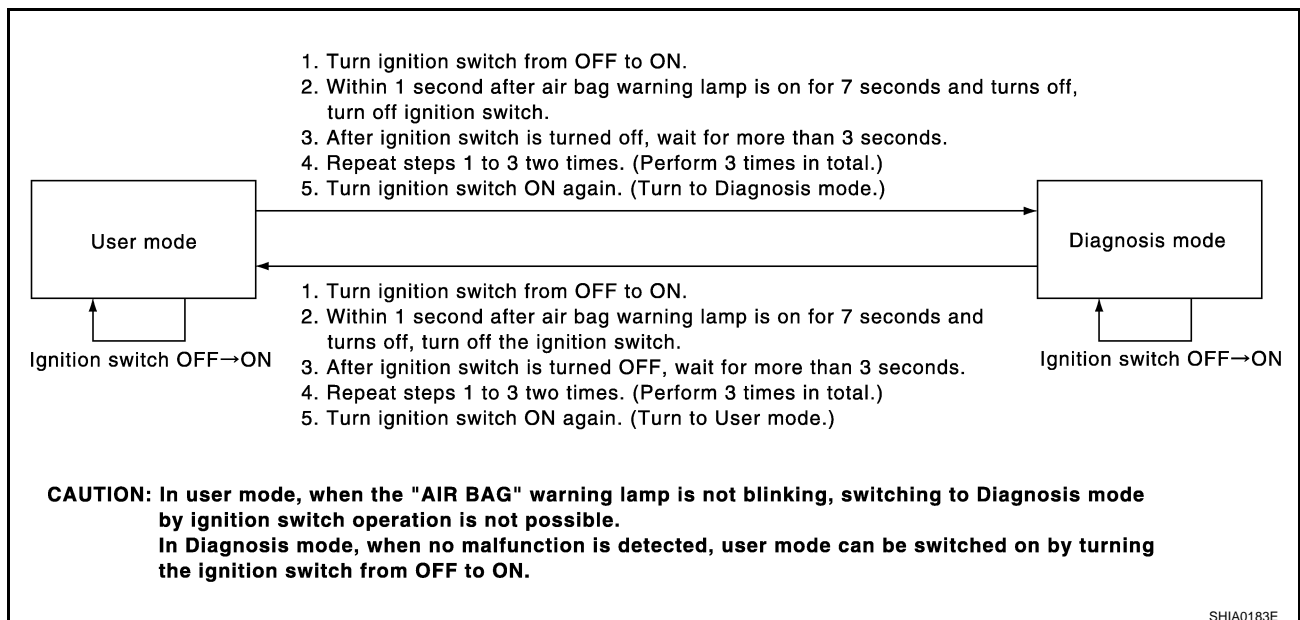

TROUBLE DIAGNOSIS

HOW TO ERASE SELF-DIAGNOSIS RESULTS

After a malfunction is repaired, turn the ignition switch OFF for at least one second, then back ON. Diagnosis mode returns to the User mode. At that time, the self-diagnostic result is cleared.

SRS Operation Check DIAGNOSTIC PROCEDURE 1

EHS001GG

Checking SRS Operation Using “AIR BAG” Warning Lamp—User Mode

1. Turn the ignition switch from OFF to ON, and check that the air bag warning lamp blinks.
2. Compare the SRS air bag warning lamp blinking pattern with the examples.

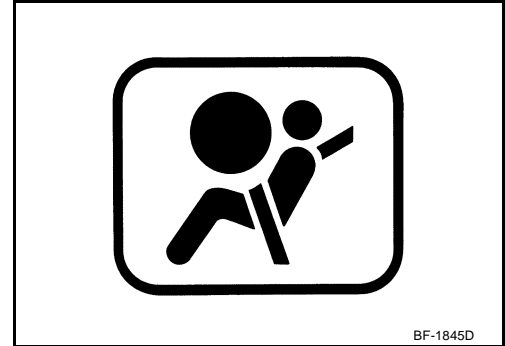

TROUBLE DIAGNOSIS

Warning lamp examples

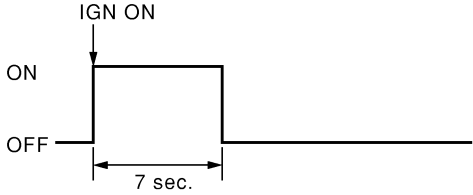
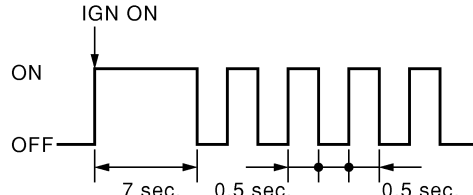
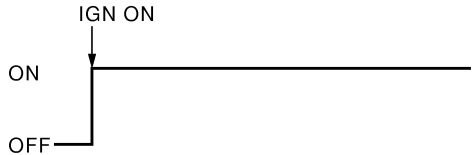
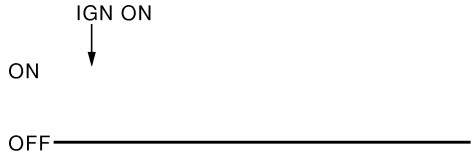
"AIR BAG" warning lamp operation-User mode-	SRS condition	Reference item
 <p style="text-align: right; font-size: small;">SHIA0011E</p>	<ul style="list-style-type: none"> ● No malfunction is detected. ● No further action is necessary. 	—
 <p style="text-align: right; font-size: small;">SHIA0012E</p>	<ul style="list-style-type: none"> ● The system is malfunctioning and needs to be repaired as indicated. 	<p>Go to SRS-22, "DIAGNOSTIC PROCEDURE 2" or SRS-35, "DIAGNOSTIC PROCEDURE 6".</p>
 <p style="text-align: right; font-size: small;">SHIA0013E</p>	<ul style="list-style-type: none"> ● Air bag is deployed. ● Seat belt pre-tensioner is deployed. 	<p>Go to SRS-57, "COLLISION DIAGNOSIS".</p>
 <p style="text-align: right; font-size: small;">SHIA0014E</p>	<ul style="list-style-type: none"> ● Air bag diagnosis sensor unit is malfunctioning. ● Air bag power supply circuit is malfunctioning. ● SRS air bag warning lamp circuit is malfunctioning. 	<p>Go to SRS-40, "Trouble Diagnosis: "AIR BAG" Warning Lamp Does Not Turn Off".</p>
	<ul style="list-style-type: none"> ● Air bag diagnosis sensor unit is malfunctioning. ● Air bag warning lamp circuit is malfunctioning. 	<p>Go to SRS-41, "Trouble Diagnosis: "AIR BAG" Warning Lamp Does Not Turn On".</p>

A

B

C

D

E

F

G

SRS

I

J

K

L

M

TROUBLE DIAGNOSIS

EHS001GH

Trouble Diagnosis With CONSULT-II DIAGNOSTIC PROCEDURE 2

CAUTION:

If CONSULT-II is used with no connection of CONSULT-II CONVERTER, malfunction might be detected in self-diagnosis depending on control unit which carries out CAN communication.

1. Turn ignition switch OFF.
2. Connect CONSULT-II and CONSULT-II CONVERTER to the data link connector.

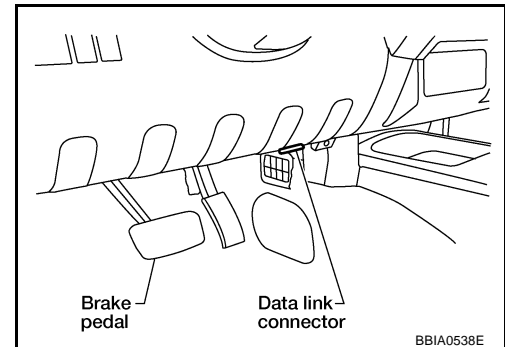

3. Turn ignition switch ON.
4. Touch "START (NISSAN BASED VHCL)".

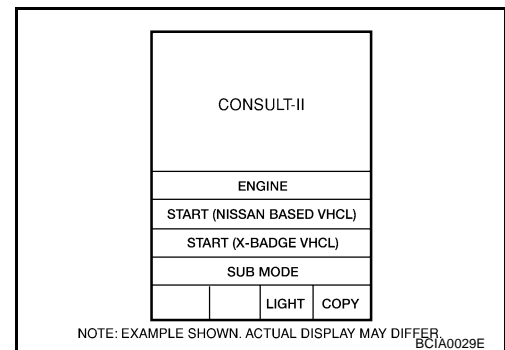

5. Touch "AIR BAG".
If "AIR BAG" is not indicated, refer to [GI-39, "CONSULT-II Data Link Connector \(DLC\) Circuit"](#).

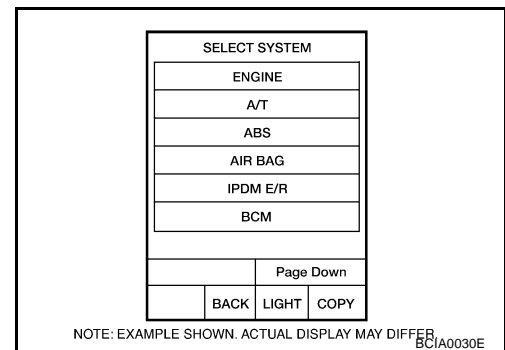

6. Touch "SELF-DIAG [CURRENT]".

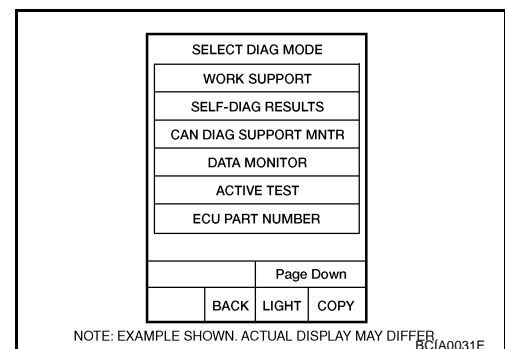

TROUBLE DIAGNOSIS

7. Diagnostic code is displayed on "SELF-DIAG [CURRENT]".

SELF-DIAG [CURRENT]
DTC RESULTS
DRIVER AIRBAG MODULE [OPEN] [B1049]

WHIA0151E

A
B
C
D
E
F
G

If no malfunction is detected on "SELF-DIAG [CURRENT]" even though malfunction is detected in "SRS Operation Check", refer to [SRS-29, "DIAGNOSTIC PROCEDURE 4 \(CONTINUED FROM DIAGNOSTIC PROCEDURE 2\)"](#) , to diagnose the following cases:

- Self-diagnostic result "SELF-DIAG [PAST]" (previously stored in the memory) might not be erased after repair.
- The SRS system malfunctions intermittently.

SELF-DIAG [CURRENT]
DTC RESULTS:
NO DTC IS DETECTED. FURTHER TESTING MAY BE REQUIRED.

SRS701

CONSULT-II Diagnostic Code Chart ("SELF-DIAG [CURRENT]")

SRS

Diagnostic item	Explanation	Repair order Recheck SRS at each replacement
NO DTC IS DETECTED	When malfunction is indicated by the "AIR BAG" warning lamp in User mode.	<ul style="list-style-type: none"> ● Low battery voltage (Less than 9V) ● Self-diagnostic result "SELF-DIAG [PAST]" (previously stored in the memory) might not be erased after repair. ● Intermittent malfunction has been detected in the past.
	● No malfunction is detected.	—
DRIVER AIRBAG MODULE [OPEN] [B1049] or [B1054]	● Driver air bag module circuit is open (including the spiral cable).	<ol style="list-style-type: none"> 1. Visually check the wiring harness connection. 2. Replace the harness if it has visible damage.
DRIVER AIRBAG MODULE [VB-SHORT] [B1050] or [B1055]	● Driver air bag module circuit is shorted to some power supply circuit (including the spiral cable).	<ol style="list-style-type: none"> 3. Replace driver air bag module. 4. Replace the spiral cable.
DRIVER AIRBAG MODULE [GND-SHORT] [B1051] or [B1056]	● Driver air bag module circuit is shorted to ground (including the spiral cable).	<ol style="list-style-type: none"> 5. Replace the air bag diagnosis sensor unit. 6. Replace the related harness.
DRIVER AIRBAG MODULE [SHORT] [B1052] or [B1057]	● Driver air bag module circuits are shorted to each other.	

I
J
K
L
M

TROUBLE DIAGNOSIS

Diagnostic item	Explanation	Repair order Recheck SRS at each replacement
ASSIST A/B MODULE [OPEN] [B1065] or [B1070]	● Front passenger air bag module circuit is open.	<ol style="list-style-type: none"> 1. Visually check the wiring harness connection. 2. Replace the harness if it has visible damage. 3. Replace front passenger air bag module. 4. Replace the air bag diagnosis sensor unit. 5. Replace the related harness.
ASSIST A/B MODULE [VB-SHORT] [B1066] or [B1071]	● Front passenger air bag module circuit is shorted to some power supply circuit.	
ASSIST A/B MODULE [GND-SHORT] [B1067] or [B1072]	● Front passenger air bag module circuit is shorted to ground.	
ASSIST A/B MODULE [SHORT] [B1068] or [B1073]	● Front passenger air bag module circuits are shorted to each other.	
CRASH ZONE SEN [UNIT FAIL] [B1033] or [B1034] CRASH ZONE SEN [COMM FAIL] [B1035]	● Crash zone sensor	<ol style="list-style-type: none"> 1. Visually check the wiring harness connection. 2. Replace the harness if it has visible damage. 3. Replace the crash zone sensor. 4. Replace the air bag diagnosis sensor unit. 5. Replace the related harness.
SIDE MODULE LH [OPEN] [B1134]	● Front LH side air bag module circuit is open.	<ol style="list-style-type: none"> 1. Visually check the wiring harness connection. 2. Replace the harness if it has visible damage. 3. Replace front LH seat back assembly (front LH side air bag module). 4. Replace the air bag diagnosis sensor unit. 5. Replace the related harness.
SIDE MODULE LH [VB-SHORT] [B1135]	● Front LH side air bag module circuit is shorted to some power supply circuit.	
SIDE MODULE LH [GND-SHORT] [B1136]	● Front LH side air bag module circuit is shorted to ground.	
SIDE MODULE LH [SHORT] [B1137]	● Front LH side air bag module circuits are shorted to each other.	
SIDE MODULE RH [OPEN] [B1129]	● Front RH side air bag module circuit is open.	<ol style="list-style-type: none"> 1. Visually check the wiring harness connection. 2. Replace the harness if it has visible damage. 3. Replace front RH seat back assembly (front RH side air bag module). 4. Replace the air bag diagnosis sensor unit. 5. Replace the related harness.
SIDE MODULE RH [VB-SHORT] [B1130]	● Front RH side air bag module circuit is shorted to some power supply circuit.	
SIDE MODULE RH [GND-SHORT] [B1131]	● Front RH side air bag module circuit is shorted to ground.	
SIDE MODULE RH [SHORT] [B1132]	● Front RH side air bag module circuits are shorted to each other.	
SATELLITE SENS LH [UNIT FAIL] [B1118] or [B1119] SATELLITE SENS LH [COMM FAIL] [B1120]	● LH side air bag (satellite) sensor	<ol style="list-style-type: none"> 1. Visually check the wiring harness connection. 2. Replace the harness if it has visible damage. 3. Replace the LH side air bag (satellite) sensor. 4. Replace the air bag diagnosis sensor unit. 5. Replace the related harness.

TROUBLE DIAGNOSIS

Diagnostic item	Explanation	Repair order Recheck SRS at each replacement	
SATELLITE SENS RH [UNIT FAIL] [B1113] or [B1114] SATELLITE SENS RH [COMM FAIL] [B1115]	<ul style="list-style-type: none"> ● RH side air bag (satellite) sensor 	<ol style="list-style-type: none"> 1. Visually check the wiring harness connection. 2. Replace the harness if it has visible damage. 3. Replace the RH side air bag (satellite) sensor. 4. Replace the air bag diagnosis sensor unit. 5. Replace the related harness. 	A B C D
PRE-TEN FRONT LH [OPEN] [B1086]	<ul style="list-style-type: none"> ● The circuit for front LH seat belt pre-tensioner is open. 	<ol style="list-style-type: none"> 1. Visually check the wiring harness connections. 2. Replace the harness if it has visible damage. 	E
PRE-TEN FRONT LH [VB-SHORT] [B1087]	<ul style="list-style-type: none"> ● The circuit for front LH seat belt pre-tensioner is shorted to some power supply circuit. 	<ol style="list-style-type: none"> 3. Replace front LH seat belt pre-tensioner. 	F
PRE-TEN FRONT LH [GND-SHORT] [B1088]	<ul style="list-style-type: none"> ● The circuit for front LH seat belt pre-tensioner is shorted to ground. 	<ol style="list-style-type: none"> 4. Replace the air bag diagnosis sensor unit. 5. Replace the related harness. 	G
PRE-TEN FRONT LH [SHORT] [B1089]	<ul style="list-style-type: none"> ● The circuits for the front LH seat belt pre-tensioner are shorted to each other. 		
PRE-TEN FRONT RH [OPEN] [B1081]	<ul style="list-style-type: none"> ● The circuit for front RH seat belt pre-tensioner is open. 	<ol style="list-style-type: none"> 1. Visually check the wiring harness connections. 2. Replace the harness if it has visible damage. 	I
PRE-TEN FRONT RH [VB-SHORT] [B1082]	<ul style="list-style-type: none"> ● The circuit for front RH seat belt pre-tensioner is shorted to some power supply circuit. 	<ol style="list-style-type: none"> 3. Replace front RH seat belt pre-tensioner. 	J
PRE-TEN FRONT RH [GND-SHORT] [B1083]	<ul style="list-style-type: none"> ● The circuit for front RH seat belt pre-tensioner is shorted to ground. 	<ol style="list-style-type: none"> 4. Replace the air bag diagnosis sensor unit. 5. Replace the related harness. 	K
PRE-TEN FRONT RH [SHORT] [B1084]	<ul style="list-style-type: none"> ● The circuits for the front RH seat belt pre-tensioner are shorted to each other. 		
CURTAIN MODULE LH [OPEN] [B1150]	<ul style="list-style-type: none"> ● The circuit for LH side curtain air bag module is open. 	<ol style="list-style-type: none"> 1. Visually check the wiring harness connection. 2. Replace the harness if it has visible damage. 	L
CURTAIN MODULE LH [VB-SHORT] [B1151]	<ul style="list-style-type: none"> ● The circuit for LH side curtain air bag module is shorted to some power supply circuits. 	<ol style="list-style-type: none"> 3. Replace LH side curtain air bag module. 	M
CURTAIN MODULE LH [GND-SHORT] [B1152]	<ul style="list-style-type: none"> ● The circuit for LH side curtain air bag module is shorted to ground. 	<ol style="list-style-type: none"> 4. Replace the air bag diagnosis sensor unit. 5. Replace the related harness. 	
CURTAIN MODULE LH [SHORT] [B1153]	<ul style="list-style-type: none"> ● The circuits for the LH side curtain air bag module are shorted to each other. 		

SRS

TROUBLE DIAGNOSIS

Diagnostic item	Explanation	Repair order Recheck SRS at each replacement
CURTAIN MODULE RH [OPEN] [B1145]	<ul style="list-style-type: none"> ● The circuit for RH side curtain air bag module is open. 	<ol style="list-style-type: none"> 1. Visually check the wiring harness connection. 2. Replace the harness if it has visible damage. 3. Replace RH side curtain air bag module. 4. Replace the air bag diagnosis sensor unit. 5. Replace the related harness.
CURTAIN MODULE RH [VB-SHORT] [B1146]	<ul style="list-style-type: none"> ● The circuit for RH side curtain air bag module is shorted to some power supply circuits. 	
CURTAIN MODULE RH [GND-SHORT] [B1147]	<ul style="list-style-type: none"> ● The circuit for RH side curtain air bag module is shorted to ground. 	
CURTAIN MODULE RH [SHORT] [B1148]	<ul style="list-style-type: none"> ● The circuits for the RH side curtain air bag module are shorted to each other. 	
CONTROL UNIT [B1XXX]	<ul style="list-style-type: none"> ● Air bag diagnosis sensor unit is malfunctioning. 	<ol style="list-style-type: none"> 1. Visually check the wiring harness connection. 2. Replace the air bag diagnosis sensor unit.
OCCUPANT SENS C/U [UNIT FAIL] [B1017], [B1020] or [B1021]	<ul style="list-style-type: none"> ● Occupant classification system is malfunctioning. 	<ol style="list-style-type: none"> 1. Replace RH front seat cushion/occupant classification system control unit assembly.
OCCUPANT SENS C/U [COMM FAIL] [B1022]	<ul style="list-style-type: none"> ● Communication between the occupant classification system control unit and air bag diagnosis sensor unit is interrupted. 	<ol style="list-style-type: none"> 1. Visually check the wiring harness connection. 2. Replace the harness if it has visible damage. 3. Replace RH front seat cushion/occupant classification system control unit assembly. 4. Replace the air bag diagnosis sensor unit. 5. Replace the related harness.
OCCUPANT SENS [UNIT FAIL] [B1018]	<ul style="list-style-type: none"> ● Occupant classification sensor is malfunctioning. 	<ol style="list-style-type: none"> 1. Replace RH front seat cushion/occupant classification system control unit assembly.
BELT TENSION SENS [UNIT FAIL] [B1019]	<ul style="list-style-type: none"> ● Belt tension sensor is malfunctioning. 	<ol style="list-style-type: none"> 1. Visually check the wiring harness connection. 2. Replace the harness if it has visible damage. 3. Replace RH front seat belt assembly. 4. Replace RH front seat cushion/occupant classification system control unit assembly.
PASS A/B INDCTR CKT [B1023]	<ul style="list-style-type: none"> ● Front passenger air bag off indicator is malfunctioning. 	<ol style="list-style-type: none"> 1. Visually check the wiring harness connection. 2. Replace the harness if it has visible damage. 3. Replace front passenger air bag off indicator. 4. Replace the air bag diagnosis sensor unit. 5. Replace the related harness.

NOTE:

Follow the procedures in numerical order when repairing malfunctioning parts. Confirm whether malfunction is eliminated using air bag warning lamp or CONSULT-II each time repair is finished. If malfunction is still observed, proceed to the next step. When malfunction is eliminated, further repair work is not required.

TROUBLE DIAGNOSIS

DIAGNOSTIC PROCEDURE 3

Final Check of SRS Using CONSULT-II—Diagnosis Mode

CAUTION:

If CONSULT-II is used with no connection of CONSULT-II CONVERTER, malfunction might be detected in self-diagnosis depending on control unit which carries out CAN communication.

1. After repairing SRS, connect both battery cables.
2. Connect CONSULT-II and CONSULT-II CONVERTER to data link connector.
3. Turn ignition switch ON.

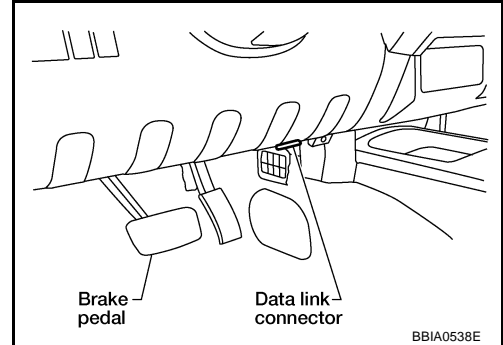

4. Touch "START (NISSAN BASED VHCL)".

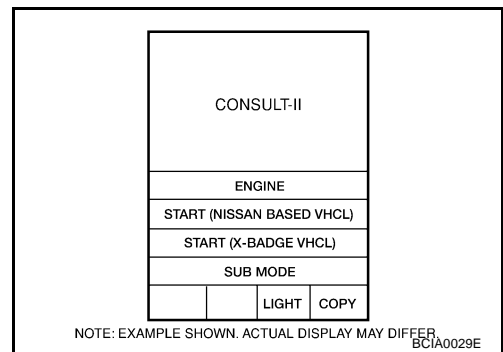

5. Touch "AIR BAG".
If "AIR BAG" is not indicated, refer to [GI-39, "CONSULT-II Data Link Connector \(DLC\) Circuit"](#).

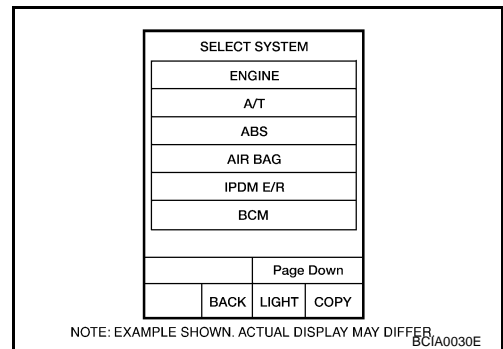

6. Touch "SELF-DIAG [CURRENT]".

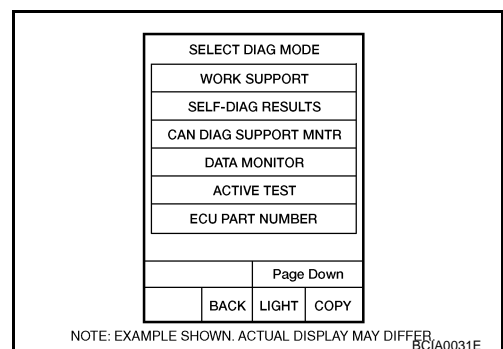

A
B
C
D
E
F
G
I
J
K
L
M

SRS

TROUBLE DIAGNOSIS

7. If no malfunction is detected on "SELF-DIAG [CURRENT]", repair of SRS is completed. Go to step 8.
 If any malfunction is detected on "SELF-DIAG [CURRENT]", the malfunctioning part is not repaired completely or another malfunctioning part is detected. Go to [SRS-22, "DIAGNOSTIC PROCEDURE 2"](#), and repair malfunctioning part completely.

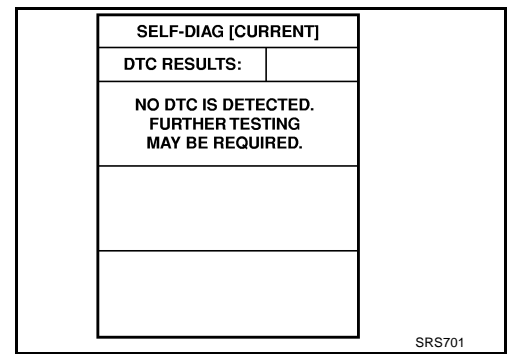

8. Touch "ERASE".

NOTE:

Touch "ERASE" to clear the memory of the malfunction ("SELF-DIAG [PAST])."

If the memory of the malfunction in "SELF-DIAG [PAST]" is not erased, the User mode shows the system malfunction by the operation of the warning lamp even if the malfunction is repaired completely.

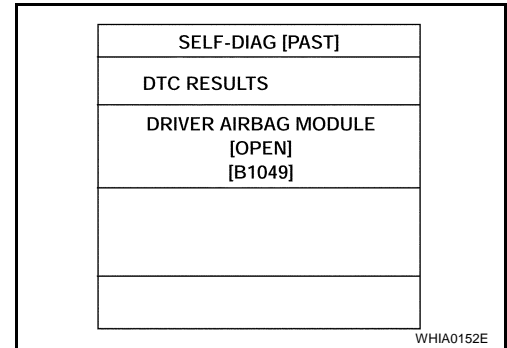

9. Touch "BACK" key of CONSULT-II to "SELECT DIAG MODE" screen. Touch "SELF-DIAG [PAST]".

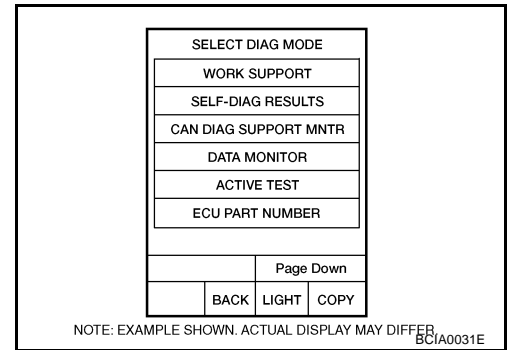

10. Check that no malfunction is detected on "SELF-DIAG [PAST]".
 11. Touch "BACK" key of CONSULT-II until "SELECT SYSTEM" appears in order to return to User mode from Diagnosis mode.
 12. Turn ignition switch OFF then turn off and disconnect CONSULT-II.
 13. Go to [SRS-20, "Checking SRS Operation Using "AIR BAG" Warning Lamp—User Mode"](#).

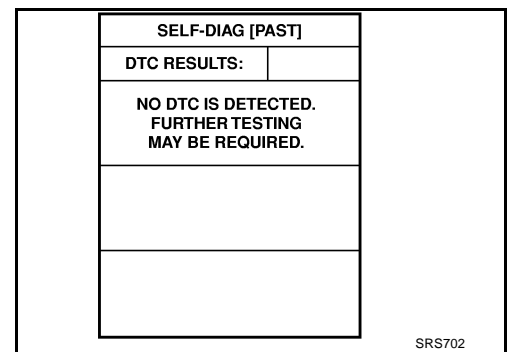

TROUBLE DIAGNOSIS

DIAGNOSTIC PROCEDURE 4 (CONTINUED FROM DIAGNOSTIC PROCEDURE 2)

Check SRS Repair History

1. CONSIDER POSSIBILITY THAT SELF-DIAGNOSTIC RESULT WAS NOT ERASED AFTER REPAIR

Check repair history of the SRS.

Have any previous repairs been made to the SRS?

- Yes >> Self-diagnostic result "SELF-DIAG [PAST]" (previously stored in the memory) might not be erased after repair. Go to [SRS-27, "DIAGNOSTIC PROCEDURE 3"](#).
- No >> Go to [SRS-22, "DIAGNOSTIC PROCEDURE 2"](#).

DIAGNOSTIC PROCEDURE 5

Check SRS Intermittent Malfunction Using CONSULT-II—Diagnosis Mode

CAUTION:

If CONSULT-II is used with no connection of CONSULT-II CONVERTER, malfunction might be detected in self-diagnosis depending on control unit which carries out CAN communication.

1. Turn ignition switch OFF.
2. Connect CONSULT-II and CONSULT-II CONVERTER to data link connector.

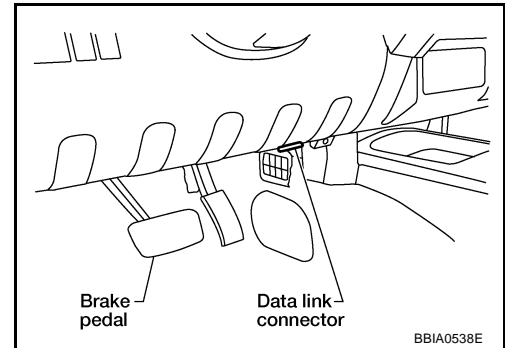

3. Turn ignition switch ON.
4. Touch "START (NISSAN BASED VHCL)".

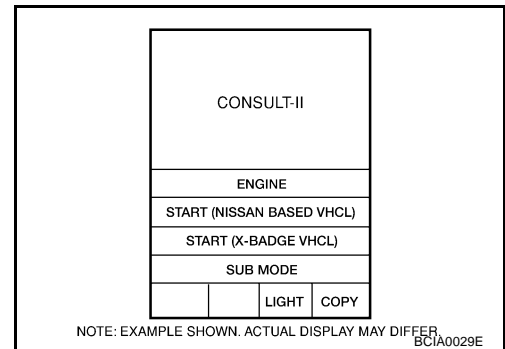

5. Touch "AIR BAG".
If "AIR BAG" is not indicated, refer to [GI-39, "CONSULT-II Data Link Connector \(DLC\) Circuit"](#).

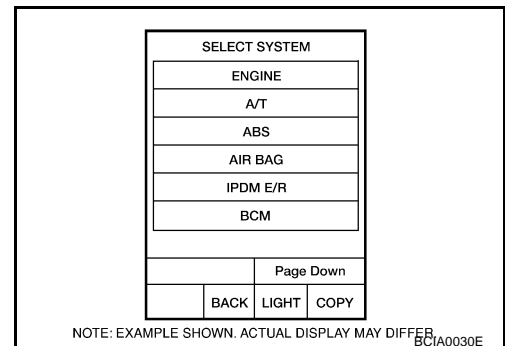

TROUBLE DIAGNOSIS

6. Touch "SELF-DIAG [PAST]".

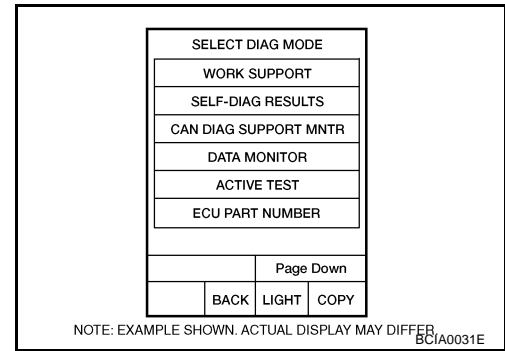

7. If diagnostic codes are displayed on "SELF-DIAG [PAST]", go to step 10.

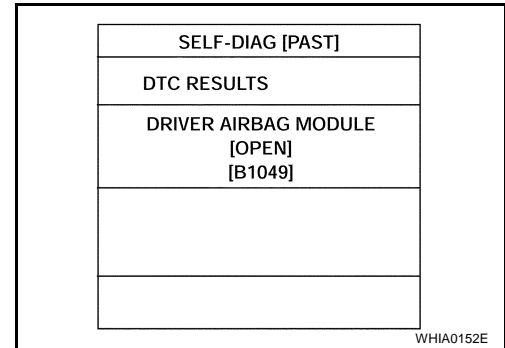

If no malfunction is detected on "SELF-DIAG [PAST]", touch "BACK" and go back to "SELECT DIAG MODE".

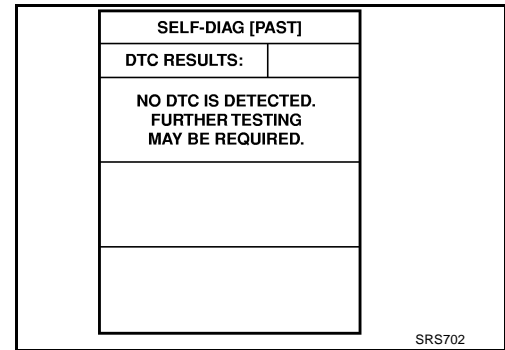

8. Touch "TROUBLE DIAG RECORD".

NOTE:
With "TROUBLE DIAG RECORD", diagnosis results previously erased by a reset operation can be displayed.

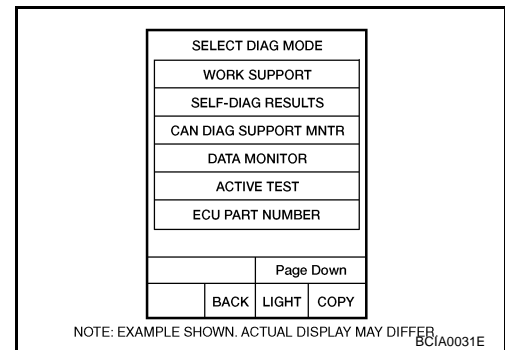

9. Diagnostic code is displayed on "TROUBLE DIAG RECORD".

10. Touch "PRINT".

11. Compare diagnostic codes to [SRS-31, "CONSULT-II Diagnostic Code Chart \("SELF-DIAG \[PAST\]" or "TROUBLE DIAG RECORD"\)"](#).

12. Touch "BACK" key of CONSULT-II until "SELECT SYSTEM" appears.

13. Turn ignition switch OFF, then turn off and disconnect CONSULT-II, and both battery cables.

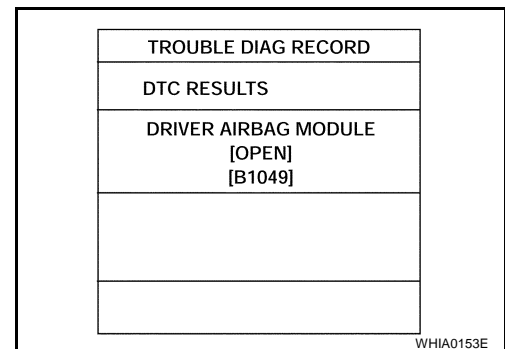

TROUBLE DIAGNOSIS

14. Repair the system as outlined by the "Repair order" in "Intermittent Malfunction Diagnostic Code Chart", that corresponds to the self-diagnostic result. For replacement procedure of component parts, refer to the Removal and Installation procedure for the appropriate component.
15. Go to [SRS-27, "DIAGNOSTIC PROCEDURE 3"](#), for final checking.

CONSULT-II Diagnostic Code Chart ("SELF-DIAG [PAST]" or "TROUBLE DIAG RECORD")

Diagnostic item	Explanation	Repair order Recheck SRS at each replacement
NO DTC IS DETECTED	When malfunction is indicated by the "AIR BAG" warning lamp in User mode. <ul style="list-style-type: none"> ● Low battery voltage (Less than 9V) ● Self-diagnostic result "SELF-DIAG [PAST]" (previously stored in the memory) might not be erased after repair. ● Intermittent malfunction has been detected in the past. 	<ul style="list-style-type: none"> ● Go to SRS-27, "DIAGNOSTIC PROCEDURE 3". ● Go to SRS-29, "DIAGNOSTIC PROCEDURE 4 (CONTINUED FROM DIAGNOSTIC PROCEDURE 2)". ● Go to SRS-29, "DIAGNOSTIC PROCEDURE 5".
	● No malfunction is detected.	—
DRIVER AIRBAG MODULE [OPEN] [B1049] or [B1054]	● Driver air bag module circuit is open (including the spiral cable).	<ol style="list-style-type: none"> 1. Visually check the wiring harness connection. 2. Replace the harness if it has visible damage.
DRIVER AIRBAG MODULE [VB-SHORT] [B1050] or [B1055]	● Driver air bag module circuit is shorted to some power supply circuit (including the spiral cable).	<ol style="list-style-type: none"> 3. Replace driver air bag module. 4. Replace the spiral cable.
DRIVER AIRBAG MODULE [GND-SHORT] [B1051] or [B1056]	● Driver air bag module circuit is shorted to ground (including the spiral cable).	<ol style="list-style-type: none"> 5. Replace the air bag diagnosis sensor unit. 6. Replace the related harness.
DRIVER AIRBAG MODULE [SHORT] [B1052] or [B1057]	● Driver air bag module circuits are shorted to each other.	
ASSIST A/B MODULE [OPEN] [B1065] or [B1070]	● Front passenger air bag module circuit is open.	<ol style="list-style-type: none"> 1. Visually check the wiring harness connection.
ASSIST A/B MODULE [VB-SHORT] [B1066] or [B1071]	● Front passenger air bag module circuit is shorted to some power supply circuit.	<ol style="list-style-type: none"> 2. Replace the harness if it has visible damage. 3. Replace front passenger air bag module.
ASSIST A/B MODULE [GND-SHORT] [B1067] or [B1072]	● Front passenger air bag module circuit is shorted to ground.	<ol style="list-style-type: none"> 4. Replace the air bag diagnosis sensor unit.
ASSIST A/B MODULE [SHORT] [B1068] or [B1073]	● Front passenger air bag module circuits are shorted to each other.	<ol style="list-style-type: none"> 5. Replace the related harness.
CRASH ZONE SEN [UNIT FAIL] [B1033] or [B1034] CRASH ZONE SEN [COMM FAIL] [B1035]	● Crash zone sensor	<ol style="list-style-type: none"> 1. Visually check the wiring harness connection. 2. Replace the harness if it has visible damage. 3. Replace the crash zone sensor. 4. Replace the air bag diagnosis sensor unit. 5. Replace the related harness.

TROUBLE DIAGNOSIS

Diagnostic item	Explanation	Repair order Recheck SRS at each replacement
SIDE MODULE LH [OPEN] [B1134]	● Front LH side air bag module circuit is open.	<ol style="list-style-type: none"> 1. Visually check the wiring harness connection. 2. Replace the harness if it has visible damage. 3. Replace front LH seat back assembly (front LH side air bag module). 4. Replace the air bag diagnosis sensor unit. 5. Replace the related harness.
SIDE MODULE LH [VB-SHORT] [B1135]	● Front LH side air bag module circuit is shorted to some power supply circuit.	
SIDE MODULE LH [GND-SHORT] [B1136]	● Front LH side air bag module circuit is shorted to ground.	
SIDE MODULE LH [SHORT] [B1137]	● Front LH side air bag module circuits are shorted to each other.	
SIDE MODULE RH [OPEN] [B1129]	● Front RH side air bag module circuit is open.	<ol style="list-style-type: none"> 1. Visually check the wiring harness connection. 2. Replace the harness if it has visible damage. 3. Replace front RH seat back assembly (front RH side air bag module). 4. Replace the air bag diagnosis sensor unit. 5. Replace the related harness.
SIDE MODULE RH [VB-SHORT] [B1130]	● Front RH side air bag module circuit is shorted to some power supply circuit.	
SIDE MODULE RH [GND-SHORT] [B1131]	● Front RH side air bag module circuit is shorted to ground.	
SIDE MODULE RH [SHORT] [B1132]	● Front RH side air bag module circuits are shorted to each other.	
SATELLITE SENS LH [UNIT FAIL] [B1118] or [B1119] SATELLITE SENS LH [COMM FAIL] [B1120]	● LH side air bag (satellite) sensor	<ol style="list-style-type: none"> 1. Visually check the wiring harness connection. 2. Replace the harness if it has visible damage. 3. Replace the LH side air bag (satellite) sensor. 4. Replace the air bag diagnosis sensor unit. 5. Replace the related harness.
SATELLITE SENS RH [UNIT FAIL] [B1113] or [B1114] SATELLITE SENS RH [COMM FAIL] [B1115]	● RH side air bag (satellite) sensor	<ol style="list-style-type: none"> 1. Visually check the wiring harness connection. 2. Replace the harness if it has visible damage. 3. Replace the RH side air bag (satellite) sensor. 4. Replace the air bag diagnosis sensor unit. 5. Replace the related harness.
PRE-TEN FRONT LH [OPEN] [B1086]	● The circuit for front LH seat belt pre-tensioner is open.	<ol style="list-style-type: none"> 1. Visually check the wiring harness connections. 2. Replace the harness if it has visible damage. 3. Replace front LH seat belt pre-tensioner. 4. Replace the air bag diagnosis sensor unit. 5. Replace the related harness.
PRE-TEN FRONT LH [VB-SHORT] [B1087]	● The circuit for front LH seat belt pre-tensioner is shorted to some power supply circuit.	
PRE-TEN FRONT LH [GND-SHORT] [B1088]	● The circuit for front LH seat belt pre-tensioner is shorted to ground.	
PRE-TEN FRONT LH [SHORT] [B1089]	● The circuits for the front LH seat belt pre-tensioner are shorted to each other.	

TROUBLE DIAGNOSIS

Diagnostic item	Explanation	Repair order Recheck SRS at each replacement	
PRE-TEN FRONT RH [OPEN] [B1081]	● The circuit for front RH seat belt pre-tensioner is open.	<ol style="list-style-type: none"> 1. Visually check the wiring harness connections. 2. Replace the harness if it has visible damage. 3. Replace front RH seat belt pre-tensioner. 4. Replace the air bag diagnosis sensor unit. 5. Replace the related harness. 	A
PRE-TEN FRONT RH [VB-SHORT] [B1082]	● The circuit for front RH seat belt pre-tensioner is shorted to some power supply circuit.		B
PRE-TEN FRONT RH [GND-SHORT] [B1083]	● The circuit for front RH seat belt pre-tensioner is shorted to ground.		C
PRE-TEN FRONT RH [SHORT] [B1084]	● The circuits for the front RH seat belt pre-tensioner are shorted to each other.		D
CURTAIN MODULE LH [OPEN] [B1150]	● The circuit for LH side curtain air bag module is open.	<ol style="list-style-type: none"> 1. Visually check the wiring harness connection. 2. Replace the harness if it has visible damage. 3. Replace LH side curtain air bag module. 4. Replace the air bag diagnosis sensor unit. 5. Replace the related harness. 	E
CURTAIN MODULE LH [VB-SHORT] [B1151]	● The circuit for LH side curtain air bag module is shorted to some power supply circuits.		F
CURTAIN MODULE LH [GND-SHORT] [B1152]	● The circuit for LH side curtain air bag module is shorted to ground.		G
CURTAIN MODULE LH [SHORT] [B1153]	● The circuits for the LH side curtain air bag module are shorted to each other.		SRS
CURTAIN MODULE RH [OPEN] [B1145]	● The circuit for RH side curtain air bag module is open.	<ol style="list-style-type: none"> 1. Visually check the wiring harness connection. 2. Replace the harness if it has visible damage. 3. Replace RH side curtain air bag module. 4. Replace the air bag diagnosis sensor unit. 5. Replace the related harness. 	I
CURTAIN MODULE RH [VB-SHORT] [B1146]	● The circuit for RH side curtain air bag module is shorted to some power supply circuits.		J
CURTAIN MODULE RH [GND-SHORT] [B1147]	● The circuit for RH side curtain air bag module is shorted to ground.		K
CURTAIN MODULE RH [SHORT] [B1148]	● The circuits for the RH side curtain air bag module are shorted to each other.		L
CONTROL UNIT [B1XXX]	● Air bag diagnosis sensor unit is malfunctioning.	<ol style="list-style-type: none"> 1. Visually check the wiring harness connection. 2. Replace the air bag diagnosis sensor unit. 	M
OCCUPANT SENS C/U [UNIT FAIL] [B1017], [B1020] or [B1021]	● Occupant classification system is malfunctioning.	1. Replace RH front seat cushion/ occupant classification system control unit assembly.	
OCCUPANT SENS C/U [COMM FAIL] [B1022]	● Communication between the occupant classification system control unit and air bag diagnosis sensor unit is interrupted.	<ol style="list-style-type: none"> 1. Visually check the wiring harness connection. 2. Replace the harness if it has visible damage. 3. Replace RH front seat cushion/ occupant classification system control unit assembly. 4. Replace the air bag diagnosis sensor unit. 5. Replace the related harness. 	
OCCUPANT SENS [UNIT FAIL] [B1018]	● Occupant classification sensor is malfunctioning.	1. Replace RH front seat cushion/ occupant classification system control unit assembly.	

TROUBLE DIAGNOSIS

Diagnostic item	Explanation	Repair order Recheck SRS at each replacement
BELT TENSION SENS [UNIT FAIL] [B1019]	<ul style="list-style-type: none"> ● Belt tension sensor is malfunctioning. 	<ol style="list-style-type: none"> 1. Visually check the wiring harness connection. 2. Replace the harness if it has visible damage. 3. Replace RH front seat belt assembly. 4. Replace RH front seat cushion/ occupant classification system control unit assembly.
PASS A/B INDCTR CKT [B1023]	<ul style="list-style-type: none"> ● Front passenger air bag off indicator is malfunctioning. 	<ol style="list-style-type: none"> 1. Visually check the wiring harness connection. 2. Replace the harness if it has visible damage. 3. Replace front passenger air bag off indicator. 4. Replace the air bag diagnosis sensor unit. 5. Replace the related harness.

TROUBLE DIAGNOSIS

Trouble Diagnosis Without CONSULT-II DIAGNOSTIC PROCEDURE 6

EHS001G1

Inspect SRS Malfunction Using "AIR BAG" Warning Lamp—Diagnosis Mode

NOTE:

SRS will not enter Diagnosis mode if no malfunction is detected in User mode.

1. Turn ignition switch ON.
2. After "AIR BAG" warning lamp lights for 7 seconds, turn ignition switch OFF within 1 second.
3. Wait more than 3 seconds.
4. Repeat steps 1 to 3 two more times (3 times total).
5. Turn ignition switch ON.

SRS is now in Diagnosis mode.

"AIR BAG" warning lamp operates in Diagnosis mode as follows:

A

B

C

D

E

F

G

SRS

I

J

K

L

M

TROUBLE DIAGNOSIS

WARNING LAMP FLASH CODE CHART

<Diagnosis results (previously stored in the memory) might not be erased after repair or intermittent malfunctions have been detected in the past.>

Flash pattern	Repair order
<p>a through b are repeated.</p> <p>IGN ON ON OFF</p> <p>7 sec. 2 sec. 3 sec. 2 sec. 2 sec. 2 sec.</p> <p>a b a b a b</p>	<p>1. Go to DIAGNOSTIC PROCEDURES 2 and 3.</p>

SHIA0026E

<Driver air bag module>	
Flash pattern	Repair order
<p>a through d are repeated. d: Two flashes indicate malfunctioning driver air bag module circuits.</p> <p>ON OFF</p> <p>7 sec. 2 sec. 3 sec. 2 sec. 2 flashes 0.5 sec. 2 sec. 3 sec. 2 sec.</p> <p>a b c d a b</p>	<ol style="list-style-type: none"> 1. Visually check the wiring harness connection. 2. Replace the harness if it has visible damage. 3. Replace the spiral cable. 4. Replace driver air bag module. 5. Replace the air bag diagnosis sensor unit. 6. Replace the related harness.

WHIA00260E

<Air bag diagnosis sensor unit>	
Flash pattern	Repair order
<p>a through d are repeated. d: Seven flashes indicate malfunctioning diagnosis sensor unit circuit.</p> <p>ON OFF</p> <p>7 sec. 2 sec. 3 sec. 2 sec. 7 flashes 0.5 sec. 2 sec. 3 sec. 2 sec.</p> <p>a b c d a b</p>	<ol style="list-style-type: none"> 1. Visually check the wiring harness connections. 2. Replace the harness if it has visible damage. 3. Replace the air bag diagnosis sensor unit. 4. Replace the related harness.

WHIA0198E

<Front passenger air bag module>	
Flash pattern	Repair order
<p>a through d are repeated. d: Eight flashes indicate malfunctioning front passenger air bag module circuit.</p> <p>ON OFF</p> <p>7 sec. 2 sec. 3 sec. 2 sec. 8 flashes 0.5 sec. 2 sec. 3 sec. 2 sec.</p> <p>a b c d a b</p>	<ol style="list-style-type: none"> 1. Visually check the wiring harness connection. 2. Replace the harness if it has visible damage. 3. Replace front passenger air bag module. 4. Replace the air bag diagnosis sensor unit. 5. Replace the related harness.

WHIA0261E

TROUBLE DIAGNOSIS

<Crash zone sensor>	
Flash pattern	Repair order
<p>a through d are repeated. d: Six flashes indicate malfunctioning crash zone sensor circuit.</p>	<ol style="list-style-type: none"> 1. Visually check the wiring harness connection. 2. Replace the harness if it has visible damage. 3. Replace the crash zone sensor. 4. Replace the air bag diagnosis sensor unit. 5. Replace the related harness.

WHIA0200E

<Front RH seat belt pre-tensioner>	
Flash pattern	Repair order
<p>a through d are repeated. d: One flash indicates malfunctioning front RH seat belt pre-tensioner circuit.</p>	<ol style="list-style-type: none"> 1. Visually check the wiring harness connections. 2. Replace the harness if it has visible damage. 3. Replace front RH seat belt pre-tensioner. 4. Replace the air bag diagnosis sensor unit. 5. Replace the related harness.

WHIA0262E

<Front LH seat belt pre-tensioner>	
Flash pattern	Repair order
<p>a through d are repeated. d: Three flashes indicate malfunctioning front LH seat belt pre-tensioner circuit.</p>	<ol style="list-style-type: none"> 1. Visually check the wiring harness connections. 2. Replace the harness if it has visible damage. 3. Replace front LH seat belt pre-tensioner. 4. Replace the air bag diagnosis sensor unit. 5. Replace the related harness.

WHIA0263E

<RH side air bag (Satellite) sensor>	
Flash pattern	Repair order
<p>a through f are repeated. f: Three flashes indicate malfunctioning RH side air bag (Satellite) sensor circuit.</p>	<ol style="list-style-type: none"> 1. Visually check the wiring harness connection. 2. Replace the harness if it has visible damage. 3. Replace the RH side air bag (Satellite) sensor. 4. Replace the air bag diagnosis sensor unit. 5. Replace the related harness.

WHIA0203E

A
B
C
D
E
F
G

SRS

I
J
K

L
M

TROUBLE DIAGNOSIS

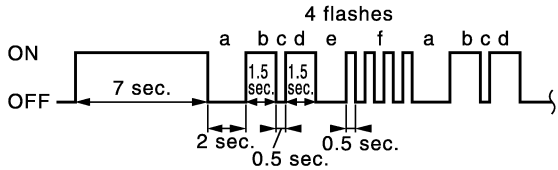
<LH side air bag (Satellite) sensor>	
Flash pattern	Repair order
<p>a through f are repeated. f: Four flashes indicate malfunctioning LH side air bag (Satellite) sensor.</p> 	<ol style="list-style-type: none"> 1. Visually check the wiring harness connection. 2. Replace the harness if it has visible damage. 3. Replace the LH side air bag (Satellite) sensor. 4. Replace the air bag diagnosis sensor unit. 5. Replace the related harness.

WHIA0204E

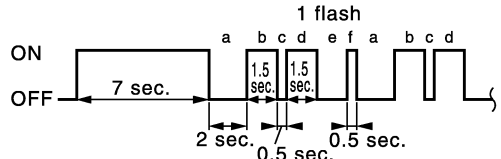
<Front RH side air bag module>	
Flash pattern	Repair order
<p>a through f are repeated. f: One flash indicate malfunctioning front RH side air bag module circuit.</p> 	<ol style="list-style-type: none"> 1. Visually check the wiring harness connection. 2. Replace the harness if it has visible damage. 3. Replace front RH seat back assembly. 4. Replace the air bag diagnosis sensor unit. 5. Replace the related harness.

WHIA0264E

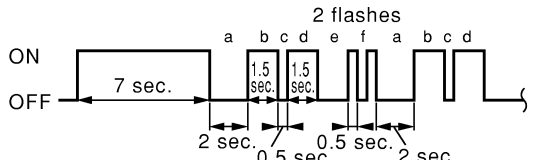
<Front LH side air bag module>	
Flash pattern	Repair order
<p>a through f are repeated. f: Two flashes indicate malfunctioning front LH side air bag module circuit.</p> 	<ol style="list-style-type: none"> 1. Visually check the wiring harness connection. 2. Replace the harness if it has visible damage. 3. Replace front LH seat back assembly. 4. Replace the air bag diagnosis sensor unit. 5. Replace the related harness.

WHIA0265E

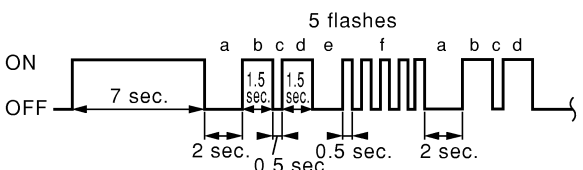
<RH side curtain air bag module>	
Flash pattern	Repair order
<p>a through f are repeated. f: Five flashes indicate malfunctioning RH side curtain air bag module circuit.</p> 	<ol style="list-style-type: none"> 1. Visually check the wiring harness connection. 2. Replace the harness if it has visible damage. 3. Replace RH side curtain air bag module. 4. Replace the air bag diagnosis sensor unit. 5. Replace the related harness.

WHIA0266E

TROUBLE DIAGNOSIS

<LH side curtain air bag module>	
Flash pattern	Repair order
<p>a through f are repeated. f: Six flashes indicate malfunctioning LH side curtain air bag module circuit.</p>	<ol style="list-style-type: none"> 1. Visually check the wiring harness connection. 2. Replace the harness if it has visible damage. 3. Replace LH side curtain air bag module. 4. Replace the air bag diagnosis sensor unit. 5. Replace the related harness.
WHIA0267E	

A
B
C
D

<Occupant classification system>	
Flash pattern	Repair order
<p>a through d are repeated. d: Five flashes indicate malfunctioning occupant classification system control unit.</p>	<ol style="list-style-type: none"> 1. Visually check the wiring harness connection. 2. Replace the harness if it has visible damage. 3. Replace the RH front seat cushion occupant classification system control unit assembly. 4. Replace the air bag diagnosis sensor unit.
WHIA0211E	

E
F
G

<Front passenger air bag off indicator>	
Flash pattern	Repair order
<p>a through d are repeated. d: Eleven flashes indicate malfunctioning front passenger air bag off indicator.</p>	<ol style="list-style-type: none"> 1. Visually check the wiring harness connection. 2. Replace the harness if it has visible damage. 3. Replace front passenger air bag off indicator. 4. Replace the air bag diagnosis sensor unit. 5. Replace the related harness.
WHIA0212E	

SRS

I
J
K
L
M

TROUBLE DIAGNOSIS

EHS001GJ

Trouble Diagnosis: "AIR BAG" Warning Lamp Does Not Turn Off DIAGNOSTIC PROCEDURE 6

1. CHECK CONDITION OF AIR BAG MODULES

Inspect for any deployed air bag modules or seat belt pre-tensioners.

Are any air bag modules or seat belt pre-tensioners deployed?

- Yes >> Refer to [SRS-57, "COLLISION DIAGNOSIS"](#).
- No >> GO TO 2.

2. CHECK THE AIR BAG FUSE

Check 10A fuse [No. 13, located in the fuse block (J/B)].
Refer to [PG-4, "POWER SUPPLY ROUTING CIRCUIT"](#).

OK or NG

- OK >> GO TO 4.
- NG >> GO TO 3.

3. CHECK AIR BAG FUSE AGAIN

Replace 10A fuse [No. 13, located in the fuse block (J/B)] and turn ignition switch ON.

Does the fuse blow again?

- Yes >> Repair harness.
- No >> Inspection End.

4. CHECK AIR BAG DIAGNOSIS SENSOR UNIT



Connect CONSULT-II and CONSULT-II CONVERTER and touch "START".

Is "AIR BAG" displayed on CONSULT-II?

- Yes >> GO TO 5.
- No >> Visually inspect the air bag diagnosis sensor unit harness connections. If the connections are OK, replace the air bag diagnosis sensor unit. Refer to [SRS-55, "Removal and Installation"](#).

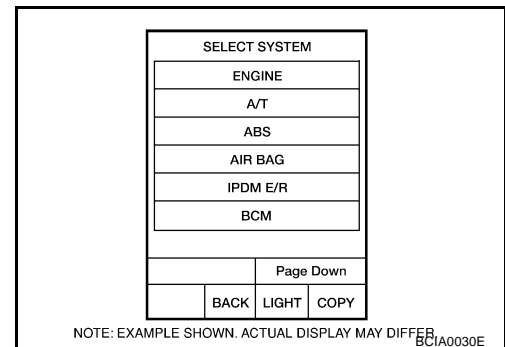

5. CHECK HARNESS CONNECTION

Check for loose connections between the combination meter and the air bag diagnosis sensor unit.

OK or NG

- OK >> Replace air bag diagnosis sensor unit. Refer to [SRS-55, "Removal and Installation"](#).
- NG >> Properly connect the combination meter and air bag diagnosis sensor unit harness connectors. If "AIR BAG" warning lamp still does not turn off, replace the wiring harness.

TROUBLE DIAGNOSIS

Trouble Diagnosis: "AIR BAG" Warning Lamp Does Not Turn On DIAGNOSTIC PROCEDURE 7

EHS001GK

1. CHECK METER FUSE

Check the 10A fuse [No. 14, located in the fuse block (J/B)].
Refer to [PG-4, "POWER SUPPLY ROUTING CIRCUIT"](#).

OK or NG

OK >> GO TO 3.
NG >> GO TO 2.

2. CHECK METER FUSE AGAIN

Replace 10A fuse [No. 14, located in the fuse block (J/B)] and turn ignition switch ON.

Does the fuse blow again?

Yes >> Repair harness.
No >> Inspection End.

3. CHECK HARNESS CONNECTION BETWEEN AIR BAG DIAGNOSIS SENSOR UNIT AND COMBINATION METER

Disconnect the air bag diagnosis sensor unit harness connectors and turn ignition switch ON.

Does "AIR BAG" warning lamp turn on?

Yes >> Replace the air bag diagnosis sensor unit. Refer to [SRS-55, "Removal and Installation"](#).
No >> Check the combination meter ground circuits.

A

B

C

D

E

F

G

SRS

I

J

K

L

M

DRIVER AIR BAG MODULE

DRIVER AIR BAG MODULE

PFK:K8510

Removal and Installation

EHS001ED

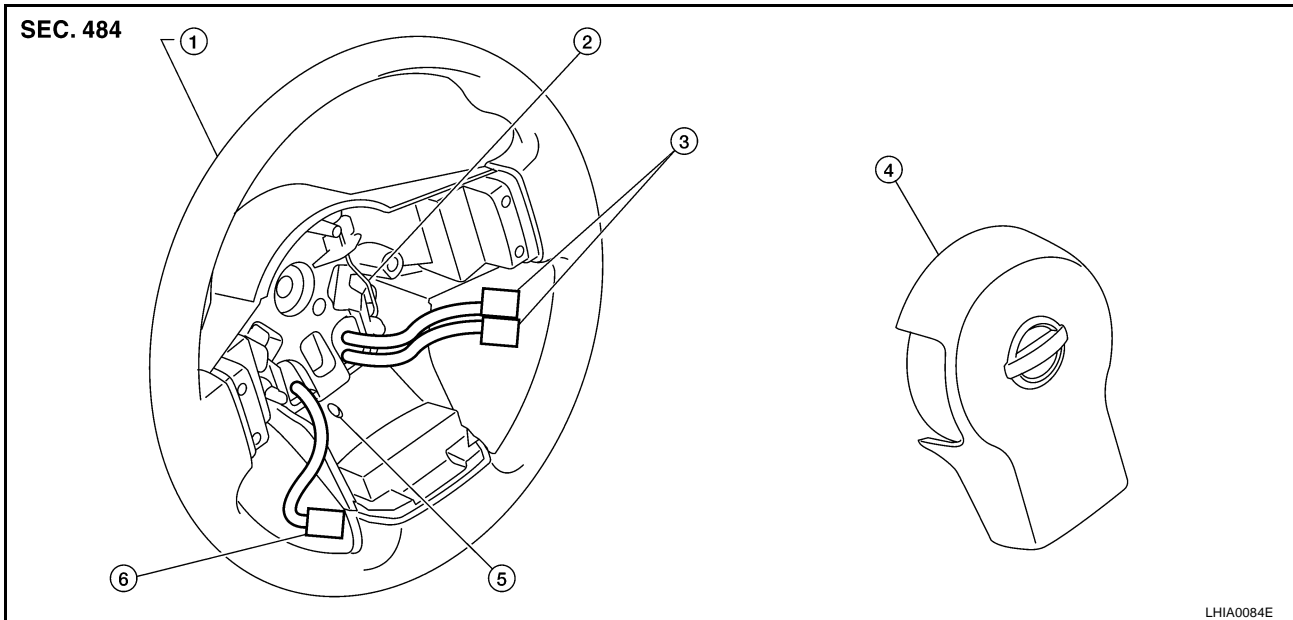

1. Steering wheel

2. Retaining clip

3. Driver air bag module connectors

4. Driver air bag module

5. Retaining clip access hole

6. Horn connector

REMOVAL

CAUTION:

- Do not attempt to repair or replace damaged direct-connect SRS component connectors. If a driver air bag direct-connect harness connector is damaged, the spiral cable must be replaced.
 - Before servicing the SRS, turn ignition switch OFF, disconnect both battery cables and wait at least 3 minutes.
 - When servicing the SRS, do not work from directly in front of air bag module.
1. Locate retaining clip access hole and insert suitable 4mm - 6mm blunt tool.

NOTE:

Do not use sharp edged objects such as screwdrivers to release driver air bag module from steering wheel, SRS components may be unintentionally damaged.

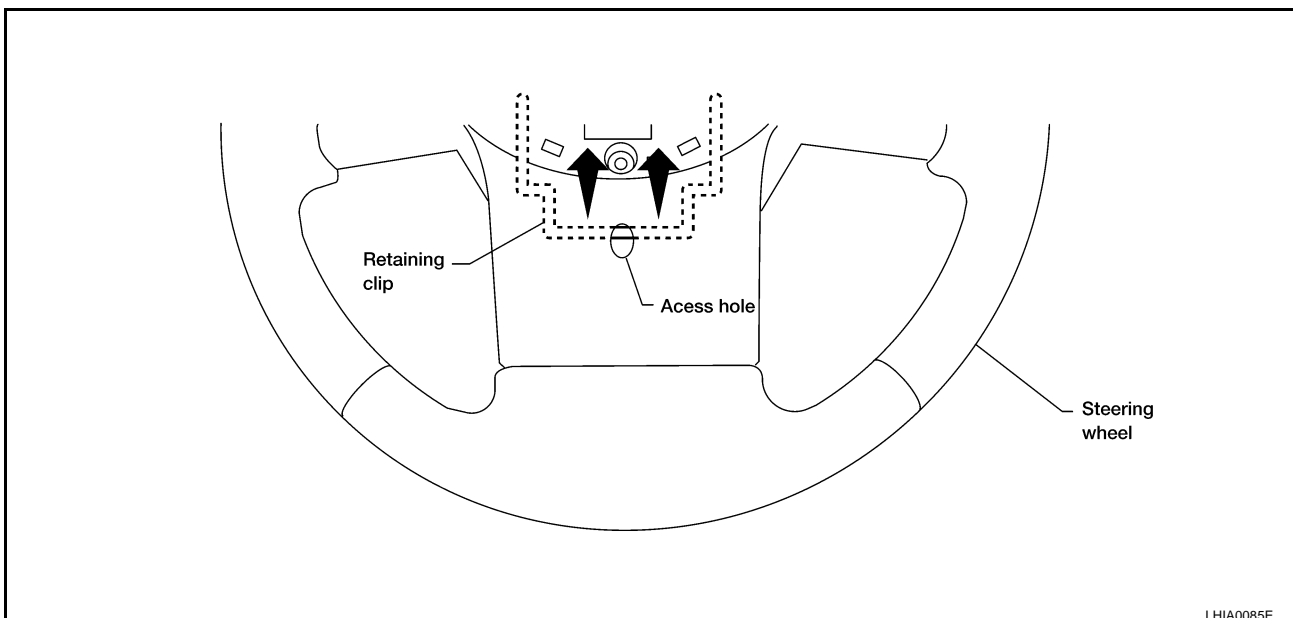

2. Press upward (toward center of steering wheel) on retaining clip until driver air bag module is released from steering wheel.

DRIVER AIR BAG MODULE

3. Lift the driver air bag module from the steering wheel.
4. Disconnect the driver air bag module and horn connectors, then remove the driver air bag module.
 - For removal/installation of the direct-connect SRS connectors, refer to [SRS-7, "Direct-connect SRS Component Connectors"](#) .

CAUTION:

- When servicing the SRS, do not work from directly in front of air bag module.
- Always place air bag module with pad side facing upward.
- Do not insert any foreign objects (screwdriver, etc.) into air bag module or connectors.
- Do not disassemble air bag module.
- Do not expose the air bag module to temperatures exceeding 90°C (194°F).

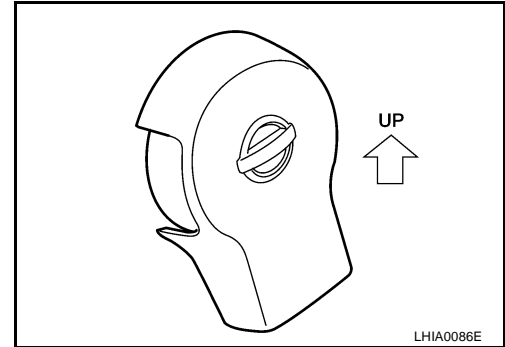

- Replace the air bag module if it has been dropped or sustained an impact.
- Do not allow oil, grease or water to come in contact with the air bag module.

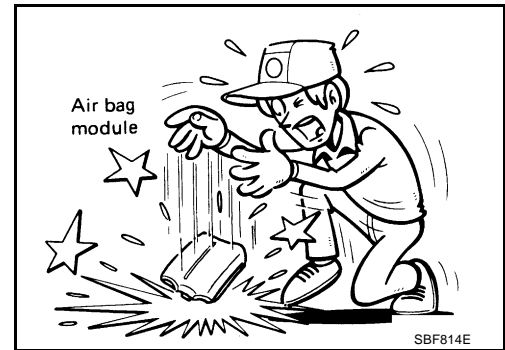

INSTALLATION

Installation is in the reverse order of installation.

- If driver air bag module is being replaced due to deployment, spiral cable must also be replaced. Refer to [SRS-44, "SPIRAL CABLE"](#) .
- For removal/installation of the direct-connect SRS connectors, refer to [SRS-7, "Direct-connect SRS Component Connectors"](#) .
- After the work is completed, perform self-diagnosis to check that no malfunction is detected. Refer to [SRS-20, "SRS Operation Check"](#) .

SPIRAL CABLE

PFP:25554

SPIRAL CABLE

Removal and Installation

EHS001EE

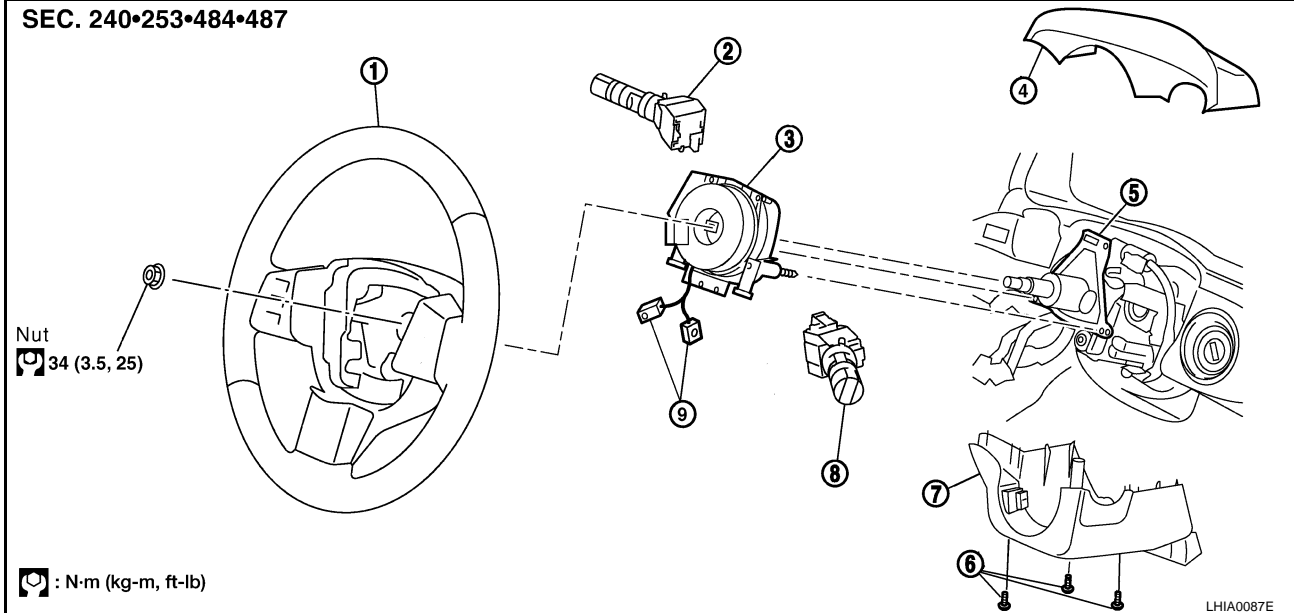

- | | | |
|-----------------------|------------------------------------|-------------------------------------|
| 1. Steering wheel | 2. Lighting and turn signal switch | 3. Spiral cable |
| 4. Column cover upper | 5. Steering column assembly | 6. Screw |
| 7. Column cover lower | 8. Wiper and washer switch | 9. Driver air bag module connectors |

REMOVAL

CAUTION:

- Before servicing the SRS, turn ignition switch OFF, disconnect both battery cables and wait at least 3 minutes.
 - When servicing the SRS, do not work from directly in front of air bag module.
1. Set the front wheels in the straight-ahead position.
 2. Remove the steering wheel. Refer to [PS-9, "Removal and Installation"](#).
 3. Remove the column cover upper and lower.
 4. Disconnect wiper and washer switch connector. Then while pressing tabs, pull wiper and washer switch away from spiral cable to remove.

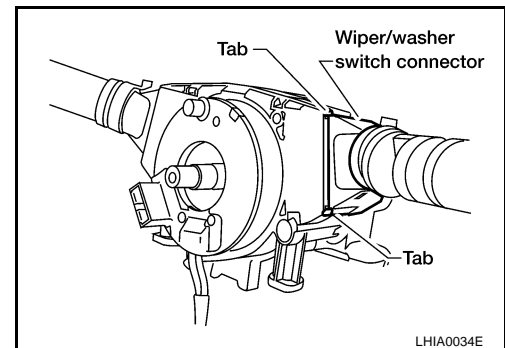

SPIRAL CABLE

5. Disconnect lighting and turn signal switch connector. Then while pressing tabs, pull lighting and turn signal switch toward driver door to remove.

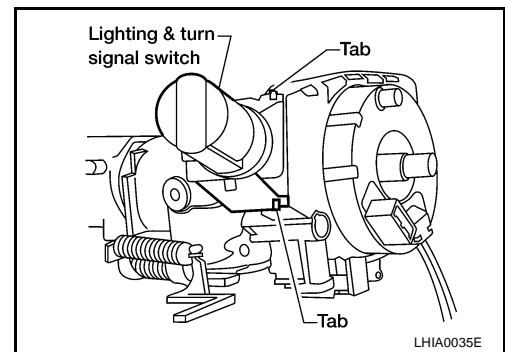

6. Remove the screws. Then while pressing the tab, pull the spiral cable away from steering column assembly.

CAUTION:

- Do not disassemble spiral cable.
- Do not apply lubricant to the spiral cable.

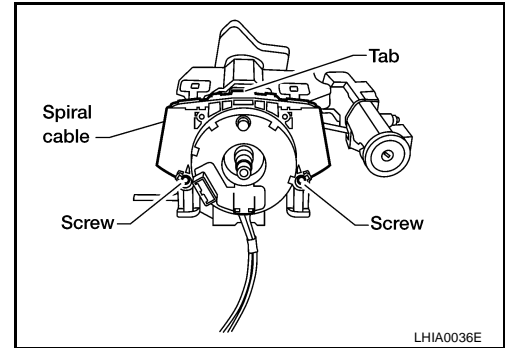

7. Disconnect the spiral cable connectors.

CAUTION:

With the steering linkage disconnected, the spiral cable may snap by turning the steering wheel beyond the limited number of turns. The spiral cable can be turned counterclockwise about 2.5 turns from the neutral position.

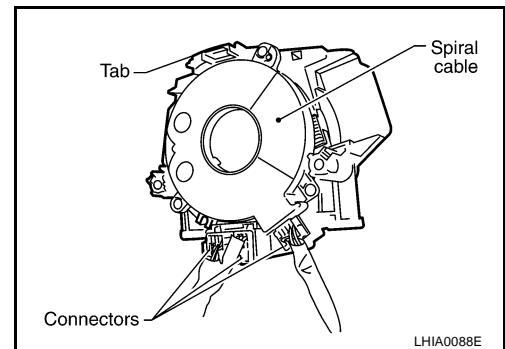

INSTALLATION

Installation is in the reverse order of removal.

- Align spiral cable correctly when installing steering wheel, refer to [PS-9, "INSTALLATION"](#). Make sure that the spiral cable is in the neutral position. The neutral position is detected by turning left 2.6 revolutions from the right end position and ending with the locating pin at the top.
- Reset the steering angle sensor calibration after installing spiral cable. Refer to [BRC-142, "Adjustment of Steering Angle Sensor Neutral Position"](#).
- After the work is completed, perform self-diagnosis to make sure no malfunction is detected. Refer to [SRS-20, "SRS Operation Check"](#).

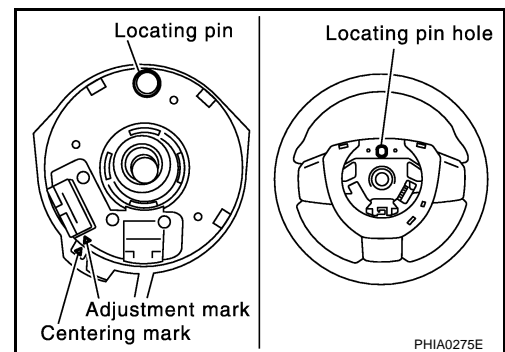

CAUTION:

- The spiral cable may snap due to steering operation if the cable is not installed in the correct position.
- With the steering linkage disconnected, the cable may snap by turning the steering wheel beyond the limited number of turns. The spiral cable can be turned counterclockwise about 2.5 turns from the neutral position.

A

B

C

D

E

F

G

SRS

I

J

K

L

M

FRONT PASSENGER AIR BAG MODULE

FRONT PASSENGER AIR BAG MODULE

PPF:K8515

Removal and Installation

EHS001EF

The passenger air bag module originally installed in the vehicle uses direct-connect style harness connectors. Service replacement passenger air bag modules use tab-locking style harness connectors. If the passenger air bag module is replaced or if the direct-connect harness connectors are damaged, the vehicle wiring harness must be modified to allow connection of the service replacement passenger air bag module. Refer to [SRS-48, "WIRING HARNESS MODIFICATION"](#) for wiring harness modification procedure.

REMOVAL

CAUTION:

- Do not attempt to repair or replace damaged direct-connect front passenger air bag module connectors. If a direct-connect harness connector is damaged, the front passenger air bag must be replaced and the wiring harness modified.
 - Before servicing SRS, turn the ignition switch off, disconnect both battery cables and wait at least 3 minutes.
 - Always work from the side of or under front passenger air bag module.
1. Remove the glove box. Refer to [IP-14, "LOWER INSTRUMENT PANEL RH AND GLOVE BOX"](#).
 2. Remove 2 bolts (through glove box opening) retaining front passenger air bag module to the steering member.
 3. Disconnect the passenger air bag module connectors.
 - For removal/installation of the direct-connect SRS connectors, refer to [SRS-7, "Direct-connect SRS Component Connectors"](#).
 4. Remove the instrument panel assembly from the vehicle. Refer to [IP-10, "INSTRUMENT PANEL"](#).

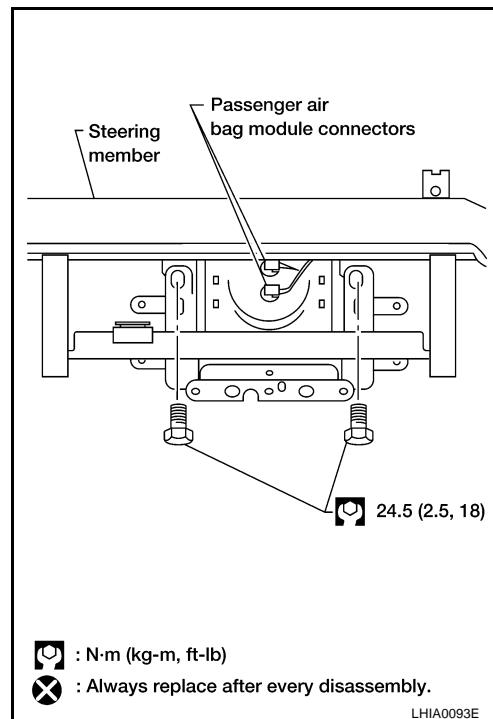

5. Remove front passenger air bag module screws then remove passenger air bag module from instrument panel assembly.

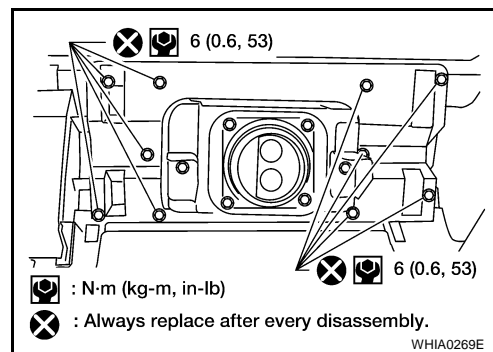

FRONT PASSENGER AIR BAG MODULE

CAUTION:

- When servicing the SRS, do not work from directly in front of air bag module.
 - Always place front passenger air bag module with caution label side facing upward.
 - Do not insert any foreign objects (screwdriver, etc.) into air bag module or harness connectors.
 - Do not disassemble air bag module.
 - Do not use old nuts after removal; replace with new nuts.
 - Do not expose the front passenger air bag module to temperatures exceeding 90°C (194°F).
-
- Replace the air bag module if it has been dropped or sustained an impact.
 - Do not allow oil, grease or water to come in contact with the air bag module.
 - For removal/installation of the direct-connect SRS connectors, refer to [SRS-7, "Direct-connect SRS Component Connectors"](#) .

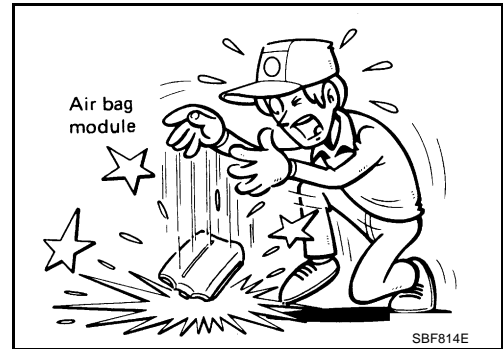
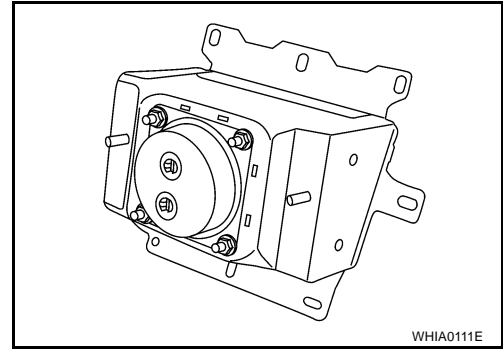

INSTALLATION

Original Passenger Air Bag Module

To install, reverse the removal procedure.

- For removal/installation of the direct-connect SRS connectors, refer to [SRS-7, "Direct-connect SRS Component Connectors"](#) .

CAUTION:

- Always work from the side of or under front passenger air bag module.
- After the work is completed, perform self-diagnosis to check that no malfunction is detected. Refer to [SRS-20, "SRS Operation Check"](#) .

Service Replacement Passenger Air Bag Module

1. Install the front passenger air bag module to the instrument panel pad assembly.

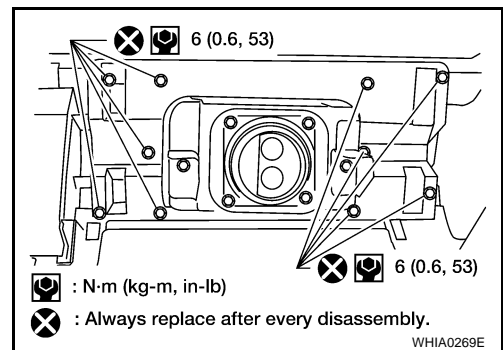

2. Install the instrument panel assembly. Refer to [IP-10, "INSTRUMENT PANEL"](#) .
3. Connect the front passenger air bag module harness connector to yellow 4-pin service replacement air bag connector and fasten connector to mounting bracket.

CAUTION:

- Always work from the side of or under front passenger air bag module.
- After the work is completed, perform self-diagnosis to check that no malfunction is detected. Refer to [SRS-20, "SRS Operation Check"](#) .

A
B
C
D
E
F
G
SRS
I
J
K
L
M

FRONT PASSENGER AIR BAG MODULE

WIRING HARNESS MODIFICATION

The passenger air bag module originally installed in the vehicle uses direct-connect style harness connectors. Service replacement passenger air bag modules use tab-locking style harness connectors. If the passenger air bag module is replaced or if the direct-connect harness connectors are damaged, the vehicle wiring harness must be modified to allow connection of the service replacement passenger air bag module.

NOTE:

The wiring harness modification is to be performed only if the vehicle is equipped with the original passenger air bag which uses direct-connect harness connectors. If the passenger air bag is to be replaced in a vehicle that has already had the service replacement passenger air bag installed, the wiring harness modification is not required.

CAUTION:

- **Do not attempt to repair or replace damaged direct-connect front passenger air bag module connectors. If a direct-connect harness connector is damaged, the front passenger air bag must be replaced and the wiring harness modified.**
- **Before servicing SRS, turn the ignition switch off, disconnect both battery cables and wait at least 3 minutes.**
- **Always work from the side of or under front passenger air bag module.**
- **After the work is completed, perform self-diagnosis to check that no malfunction is detected. Refer to [SRS-20, "SRS Operation Check"](#) .**

1. Locate the yellow and orange direct-connect passenger air bag module harness connectors.
2. Use wire cutters to cut back both previously used direct-connect passenger air bag module harness connectors from the vehicle wiring harness approximately 50 mm (1.9 in) from the connectors.
3. Remove approximately 150 mm (5.9 in) of the vehicle harness covering from the cut end.
4. Slide a piece of dual-wall heat shrink tubing (provided in the passenger air bag service kit) onto each wire of the previously used vehicle wiring harness.

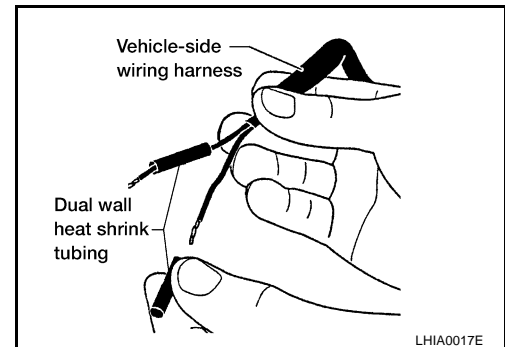

5. Fold each wire back and insert into the end of the heat shrink tubing so that the end of the wire is approximately centered in the heat shrink tubing.

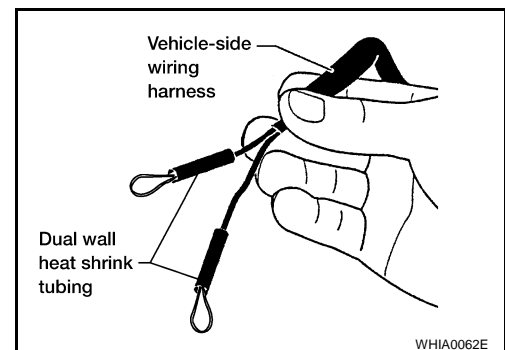

6. Use a heat gun to shrink the heat shrink tubing and seal the wire.
7. Use electrical tape to secure the modified circuits to the outside of the wiring harness.

FRONT PASSENGER AIR BAG MODULE

8. Locate the front passenger air bag service replacement connector that is taped back to the main harness. Unwrap the tape to access the yellow service replacement connector and remove the dust cover from the connector.

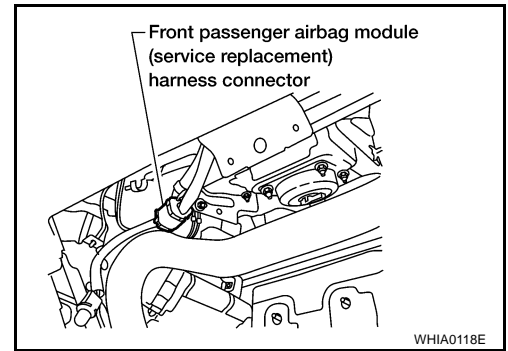

A

B

C

D

E

F

G

SRS

I

J

K

L

M

SIDE CURTAIN AIR BAG MODULE

SIDE CURTAIN AIR BAG MODULE

PPF:985P0

Removal and Installation

EHS001EH

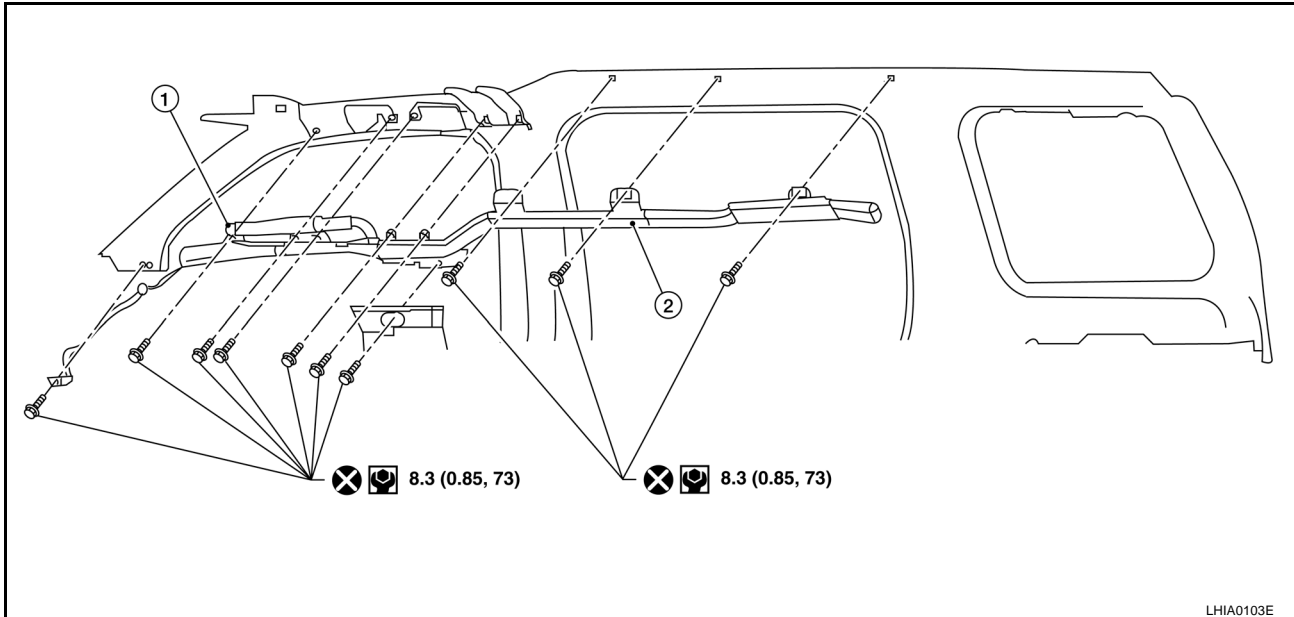

1. Side curtain air bag module connector 2. Side curtain air bag module

REMOVAL

CAUTION:

- Do not attempt to repair or replace damaged direct-connect SRS component connectors. If a direct-connect harness connector is damaged, the harness must be replaced.
 - Before servicing the SRS, turn the ignition switch off, disconnect both battery cables and wait at least 3 minutes.
 - When servicing the SRS, do not work from directly in front of air bag module.
1. Remove headlining. Refer to [EI-31, "Removal and Installation"](#).
 2. Disconnect front and rear side curtain air bag module connectors.
 - For removal/installation of the direct-connect SRS connectors, refer to [SRS-7, "Direct-connect SRS Component Connectors"](#).
 3. Remove the bolts in order starting at the front or rear, and remove the side curtain air bag module.

CAUTION:

- When servicing the SRS, do not work from directly in front of air bag module.
- Do not insert any foreign objects (screwdriver, etc.) into air bag module or harness connectors.
- Do not disassemble air bag module.
- Do not expose the air bag module to temperatures exceeding 90°C (194°F).
- Replace side curtain air bag module if it has been dropped or sustained an impact.
- Do not allow oil, grease or water to come in contact with the air bag module.

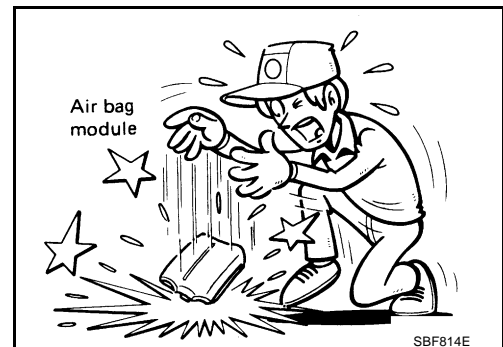

INSTALLATION

Installation is in the reverse order of removal.

SIDE CURTAIN AIR BAG MODULE

- For removal/installation of the direct-connect SRS connectors, refer to [SRS-7, "Direct-connect SRS Component Connectors"](#) .
- After replacement of side curtain air bag module, perform self-diagnosis to check that no malfunction is detected. Refer to [SRS-20, "SRS Operation Check"](#) .

A

B

C

D

E

F

G

SRS

I

J

K

L

M

CRASH ZONE SENSOR

PFP:98531

EHS001EI

CRASH ZONE SENSOR

Removal and Installation REMOVAL

CAUTION:

- Before servicing the SRS, turn the ignition switch off, disconnect both battery cables and wait at least 3 minutes.
1. Remove crash zone sensor nuts and shield from support member.
 2. Disconnect the crash zone sensor harness connector.
 3. Remove crash zone sensor.

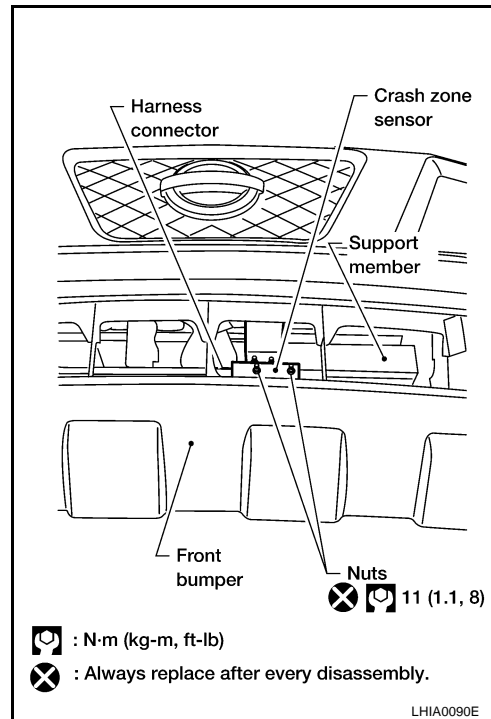

CAUTION:

- Replace crash zone sensor if it has been dropped or sustained an impact.
- Do not disassemble crash zone sensor.

INSTALLATION

Installation is in the reverse order of removal.

- After the work is complete, perform self-diagnosis to check that no malfunction is detected. Refer to [SRS-20, "SRS Operation Check"](#).

SIDE AIR BAG (SATELLITE) SENSOR

PFP:98830

EHS001EJ

SIDE AIR BAG (SATELLITE) SENSOR

Removal and Installation REMOVAL

CAUTION:

- Before servicing the SRS, turn the ignition switch off, disconnect both battery cables and wait at least 3 minutes.
1. Remove front door sill finisher and lift carpet.

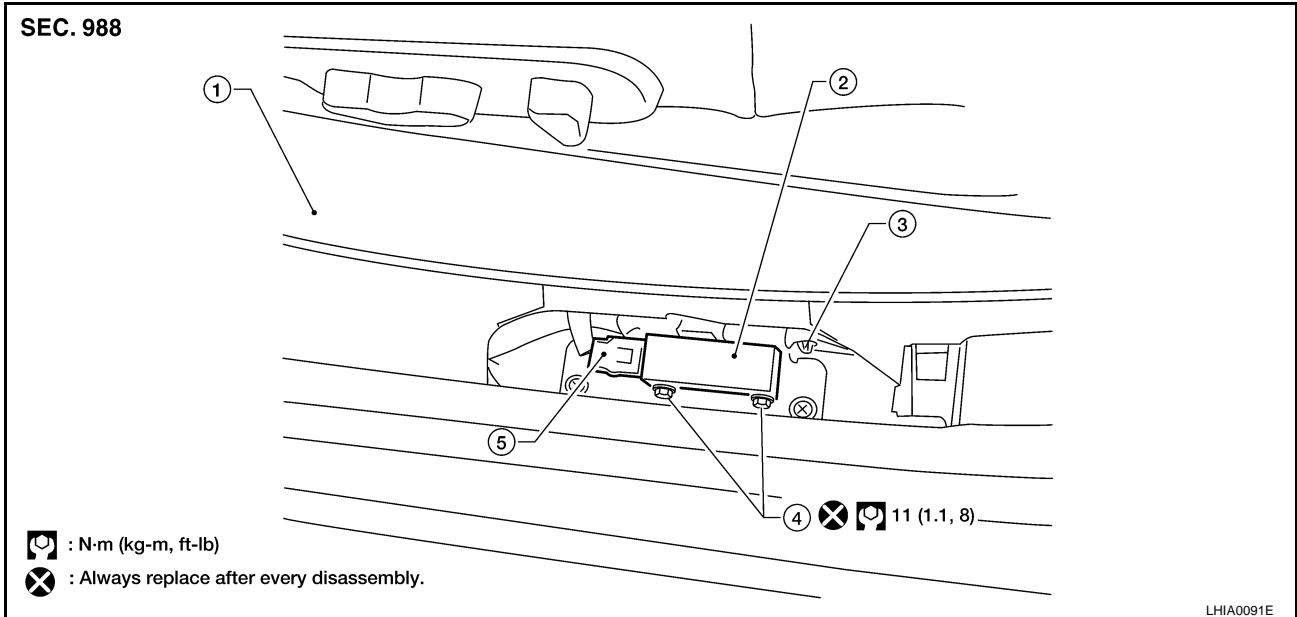

1. Front seat finisher
2. Side air bag (satellite) sensor
3. Clip
4. Nuts
5. Side air bag (Satellite) sensor connector

2. Remove side air bag (satellite) sensor nuts and release the clip.
3. Disconnect the side air bag (satellite) sensor connector.

CAUTION:

- Do not use old nuts after removal; replace with new nuts.
- Check side air bag (satellite) sensor to ensure it is free of deformities, dents, cracks or rust. If it shows any visible signs of damage, replace it with new one.
- Do not disassemble side air bag (satellite) sensor.
- Replace side air bag (satellite) sensor if it has been dropped or sustained an impact.

INSTALLATION

Installation is in the reverse order of removal.

- After the work is completed, perform self-diagnosis to check that no malfunction is detected. Refer to [SRS-20, "SRS Operation Check"](#).

FRONT SEAT BELT PRE-TENSIONER

FRONT SEAT BELT PRE-TENSIONER

PF8:86884

Removal and Installation

EHS001EK

For removal and installation procedures, refer to [SB-3, "Removal and Installation of Front Seat Belt"](#) .

DIAGNOSIS SENSOR UNIT

PF2:28556

EHS001EL

DIAGNOSIS SENSOR UNIT

Removal and Installation REMOVAL

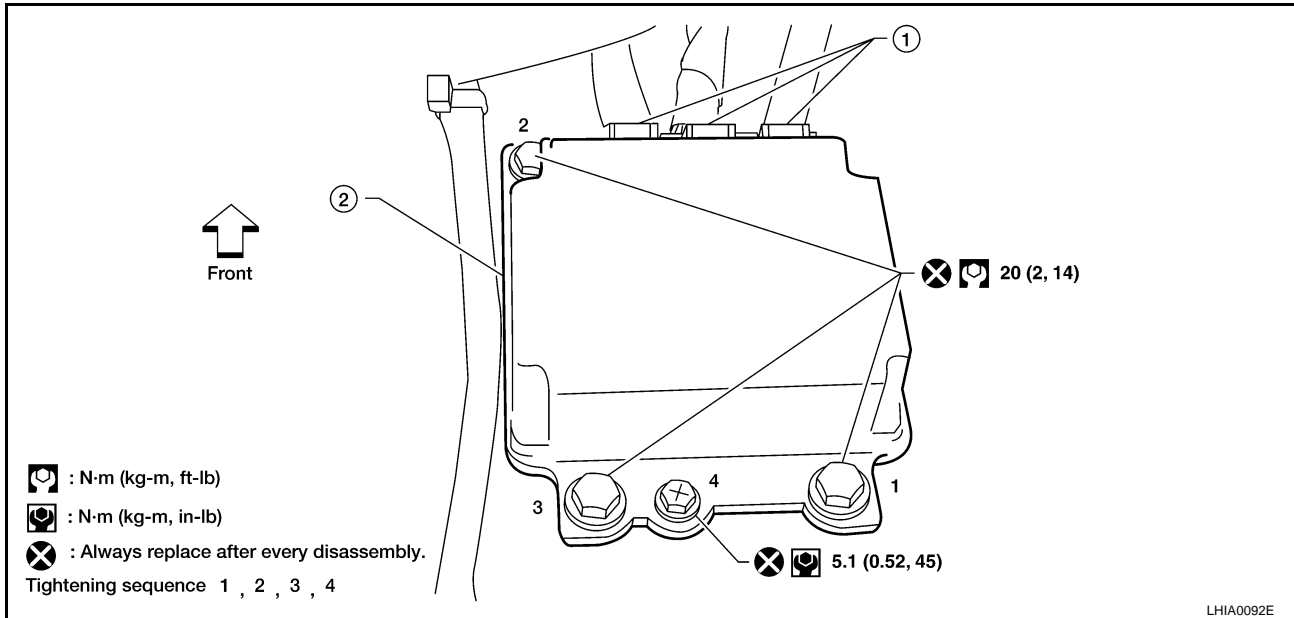

1. Diagnosis sensor unit connectors
2. Diagnosis sensor unit

CAUTION:

- Before servicing the SRS, turn the ignition switch off, disconnect both battery cables and wait at least 3 minutes.
1. Disconnect the connectors for each air bag module and seat belt pre-tensioner.
 2. Remove center console. Refer to [IP-10, "INSTRUMENT PANEL ASSEMBLY"](#).
 3. Disconnect diagnosis sensor unit connectors.
 4. Remove bolts from the diagnosis sensor unit.

CAUTION:

- Do not use old bolts; replace with new bolts.
- Check diagnosis sensor unit bracket to ensure it is free of deformities, dents, cracks or rust. If it shows any visible signs of damage, replace with new one.
- Replace diagnosis sensor unit if it has been dropped or sustained an impact.

INSTALLATION

Installation is in the reverse order of removal.

- After the work is completed, perform self-diagnosis to check that no malfunction is detected. Refer to [SRS-20, "SRS Operation Check"](#).

CAUTION:

- The diagnosis sensor unit must always be installed with the arrow mark "←" pointing toward the front of the vehicle for proper operation.

ECU DISCRIMINATED NO.

After replacing the diagnosis sensor unit, confirm that the diagnosis sensor unit identification is correct for the vehicle as equipped. Refer to [SRS-18, "CONSULT-II Function \(AIR BAG\)"](#).

A
B
C
D
E
F
G

SRS

I
J
K
L
M

OCCUPANT CLASSIFICATION SYSTEM CONTROL UNIT

OCCUPANT CLASSIFICATION SYSTEM CONTROL UNIT

PFP:98852

Removal and Installation

EHS001EM

The occupant classification control unit, occupant classification (pressure) sensor, and bladder are an integral part of the front passenger seat cushion and are replaced as an assembly. Refer to [SE-13, "REMOVAL"](#) to remove the seat, and [SE-14, "SEAT CUSHION TRIM AND PAD"](#) to replace the seat cushion.

COLLISION DIAGNOSIS

PFP:00015

COLLISION DIAGNOSIS

For Frontal Collision

EHS001EO

Check the SRS components using the following table.

- After the work is completed, perform self-diagnosis to check that no malfunction is detected. Refer to [SRS-20, "SRS Operation Check"](#).

SRS INSPECTION (FOR FRONTAL COLLISION)

Part	SRS is activated	SRS is NOT activated
Air bag module (driver and front passenger air bag module)	REPLACE Install with new fasteners.	<ol style="list-style-type: none"> Remove air bag module. Check harness cover and connectors for damage, terminals for deformities, and harness for binding. Install driver air bag module into the steering wheel to check fit and alignment with the wheel. Install passenger air bag module into the instrument panel to check fit with the instrument panel. If no damage is found, reinstall with new fasteners. If damaged—REPLACE. Install air bag modules with new fasteners.
Crash zone sensor	REPLACE the crash zone sensor and bracket with new fasteners.	<ol style="list-style-type: none"> Remove the crash zone sensor. Check harness connectors for damage, terminals for deformities, and harness for binding. Check for visible signs of damage (dents, cracks, deformation) of the crash zone sensor and bracket. Install the crash zone sensor to check fit. If no damage is found, reinstall with new fasteners. If damaged—REPLACE the crash zone sensor and bracket with new fasteners.
Seat belt pre-tensioner assemblies	REPLACE Install seat belt pre-tensioner with new fasteners.	<ol style="list-style-type: none"> Remove seat belt pre-tensioners. Check harness cover and connectors for damage, terminals for deformities, and harness for binding. Check belts for damage and anchors for loose mounting. Check retractor for smooth operation. Check seat belt adjuster for damage. If no damage is found, reinstall seat belt pre-tensioner assembly. If damaged—REPLACE. Install the seat belt pre-tensioners with new fasteners.
Diagnosis sensor unit	REPLACE Install with new fasteners.	<ol style="list-style-type: none"> Check case for dents, cracks or deformities. Check connectors for damage, and terminals for deformities. If no damage is found, reinstall with new fasteners. If damaged—REPLACE. Install diagnosis sensor unit with new fasteners.
Steering wheel		<ol style="list-style-type: none"> Visually check steering wheel for deformities. Check harness (built into steering wheel) and connectors for damage, and terminals for deformities. Install driver air bag module into the steering wheel to check fit and alignment with the wheel. Check steering wheel for excessive free play. If no damage is found, reinstall. If damaged—REPLACE.
Spiral cable	REPLACE the spiral cable.	<ol style="list-style-type: none"> Visually check spiral cable and combination switch for damage. Check connectors and protective tape for damage. Check steering wheel for noise, binding or heavy operation. If no damage is found, reinstall. If damaged—REPLACE.

A

B

C

D

E

F

G

SRS

I

J

K

L

M

COLLISION DIAGNOSIS

Part	SRS is activated	SRS is NOT activated
Occupant classification system (Passenger seat)	<ol style="list-style-type: none"> 1. Remove passenger seat. 2. Check control unit case for dents, cracks or deformities. 3. Check connectors and pressure sensor tube for damage, and terminals for deformities. 4. Check the seat cushion frame and pan for any deformation, dents, cracks, or rust. Replace damaged components as necessary. (The occupant classification system will not function as designed with deformities in any of its components.) 5. If no damage is found, reinstall seat with new fasteners. 6. If damaged — REPLACE seat cushion assembly with new fasteners. 	
Harness and connectors	<ol style="list-style-type: none"> 1. Check connectors for poor connection, damage, and terminals for deformities. 2. Check harness for binding, chafing, cuts, or deformities. 3. If no damage is found, reinstall the harness and connectors. 4. If damaged—REPLACE the damaged harness. Do not attempt to repair, splice or modify any SRS harness. 	
Instrument panel	REPLACE the instrument panel assembly.	<ol style="list-style-type: none"> 1. Visually check instrument panel for damage. 2. If no damage is found, reinstall the instrument panel. 3. If damaged—REPLACE the instrument panel.

For Side Collision

EHS001EP

Check the SRS components using the following table.

- After the work is completed, perform self-diagnosis to check that no malfunction is detected. Refer to [SRS-20, "SRS Operation Check"](#).

WHEN SRS IS ACTIVATED IN THE SIDE COLLISION

1. Replace the following components:
 - Front seat back assembly (on the side on which side air bag is activated)
 - Diagnosis sensor unit
 - (LH or RH) side air bag (satellite) sensor (on the side on which side air bag is activated)
2. Check the SRS components and the related parts using the following table.
 - Replace any SRS components and the related parts showing visible signs of damage (dents, cracks, deformation).
3. Conduct self-diagnosis using CONSULT-II and "AIR BAG" warning lamp. Refer to [SRS-20, "SRS Operation Check"](#) for details. Ensure entire SRS operates properly.

WHEN SRS IS NOT ACTIVATED IN THE SIDE COLLISION

1. Check the SRS components and the related parts using the following table.
 - If the front seat back assembly is damaged, the front seat back assembly must be replaced.
2. Conduct self-diagnosis using CONSULT-II and "AIR BAG" warning lamp. Refer to [SRS-20, "SRS Operation Check"](#) for details. Ensure entire SRS operates properly.

SRS INSPECTION (FOR SIDE COLLISION)

Part	SRS is activated	SRS is NOT activated
(LH or RH) side curtain air bag module	Replace the side curtain air bag module. (Repair the center pillar inner, etc. before installing new one if damaged.)	<ol style="list-style-type: none"> 1. Check for visible signs of damage (dents, tears, deformation) of the center pillar on the collision side. 2. If damaged—Remove the side curtain air bag module. 3. Check for visible signs of damaged (tears etc.) of the side curtain air bag module. 4. Check harness and connectors for damage, and terminals for deformities. 5. If no damage is found, reinstall the side curtain air bag module with new fasteners. 6. If damaged—REPLACE the side curtain air bag module with new fasteners.
Front (LH or RH) side air bag module	REPLACE front seat-back assembly.	<ol style="list-style-type: none"> 1. Check for visible signs of damage (dents, tears, deformation) of the seat back on the collision side. 2. Check harness and connectors for damage, and terminals for deformities. 3. If damaged—REPLACE the front seatback assembly.

COLLISION DIAGNOSIS

Part	SRS is activated	SRS is NOT activated	
(LH or RH) side air bag (satellite) sensor	REPLACE the side air bag (satellite) sensor on the collision side with new fasteners. (Repair the center pillar inner, etc. before installing new one if damaged.)	<ol style="list-style-type: none"> 1. Remove the side air bag (satellite) sensor on the collision side. Check harness connectors for damage, terminals for deformities, and harness for binding. 2. Check for visible signs of damage (dents, cracks, deformation) of the side air bag (satellite) sensor. 3. Install the side air bag (satellite) sensor to check fit. 4. If no damage is found, reinstall the side air bag (satellite) sensor with new fasteners. 5. If damaged—REPLACE the side air bag (satellite) sensor with new fasteners. 	A B C
Diagnosis sensor unit	REPLACE the diagnosis sensor unit with new fasteners.	<ol style="list-style-type: none"> 1. Check case and bracket for dents, cracks or deformities. 2. Check connectors for damage, and terminals for deformities. 3. If no damage is found, reinstall the diagnosis sensor unit with new fasteners. 4. If damaged—REPLACE the diagnosis sensor unit with new fasteners. 	D
Seat belt pre-tensioner assembly	<ol style="list-style-type: none"> 1. Check if the seat belt can be extended smoothly. If the seat belt cannot be extended smoothly, <ul style="list-style-type: none"> – Check for deformities of the center pillar inner. – If the center pillar inner has no damage, REPLACE the seat belt pre-tensioner assembly. 2. Remove the seat belt pre-tensioner assembly on the collision side. Check harness cover and connectors for damage, terminals for deformities, and harness for binding. 3. Check for visible signs of damage (dents, cracks, deformation) of the seat belt pre-tensioner assembly. 4. Check seat belt adjuster for damage. 5. If no damage is found, reinstall the seat belt pre-tensioner assembly. 6. If damaged—REPLACE the seat belt pre-tensioner assembly with new fasteners. 		E F G
Seat (with front side air bag)	REPLACE front seat-back assembly.	<ol style="list-style-type: none"> 1. Visually check the seat on the collision side. 2. Remove the seat on the collision side and check the following for damage and deformities. <ul style="list-style-type: none"> – Harness, connectors and terminals – Frame and recliner (for front and rear seat), and also adjuster and slides (for front seat) 3. If no damage is found, reinstall the seat. 4. If damaged—REPLACE the damaged seat parts using new fasteners. If the front seat back is damaged, the front seat back assembly must be replaced. 	I J K
Center inner pillar	<ol style="list-style-type: none"> 1. Check the center inner pillar on the collision side for damage (dents, cracks, deformation). 2. If damaged—REPAIR the center inner pillar. 		
Trim/headlining	<ol style="list-style-type: none"> 1. Check for visible signs of damage (dents, cracks, deformation) of the interior trim on the collision side. 2. If damaged—REPLACE the damaged trim parts. 		L

SRS

For Rollover

EHS001EQ

Check the SRS components using the following table.

- After the work is completed, perform self-diagnosis to check that no malfunction is detected. Refer to [SRS-20, "SRS Operation Check"](#).

WHEN SRS IS ACTIVATED IN THE ROLLOVER

1. Replace the following components:
 - Diagnosis sensor unit
 - (LH or RH) side air bag (satellite) sensor (on the side on which side air bag is activated)
2. Check the SRS components and the related parts using the following table.
 - Replace any SRS components and the related parts showing visible signs of damage (dents, cracks, deformation).
3. Conduct self-diagnosis using CONSULT-II and "AIR BAG" warning lamp. Refer to [SRS-20, "SRS Operation Check"](#) for details. Ensure entire SRS operates properly.

WHEN SRS IS NOT ACTIVATED IN THE ROLLOVER

1. Check the SRS components and the related parts using the following table.

COLLISION DIAGNOSIS

- If the front seat back assembly is damaged, the front seat back assembly must be replaced.
- 2. Conduct self-diagnosis using CONSULT-II and "AIR BAG" warning lamp. Refer to [SRS-20, "SRS Operation Check"](#) for details. Ensure entire SRS operates properly.

SRS INSPECTION (FOR ROLLOVER)

Part	SRS is activated	SRS is NOT activated
(LH or RH) side curtain air bag module	Replace the side curtain air bag module. (Repair the center pillar inner, etc. before installing new one if damaged.)	<ol style="list-style-type: none"> 1. Check for visible signs of damage (dents, tears, deformation) of the center pillar on the collision side. 2. If damaged—Remove the side curtain air bag module. 3. Check for visible signs of damaged (tears etc.) of the side curtain air bag module. 4. Check harness and connectors for damage, and terminals for deformities. 5. If no damage is found, reinstall the side curtain air bag module with new fasteners. 6. If damaged—REPLACE the side curtain air bag module with new fasteners.
Front (LH or RH) side air bag module	REPLACE front seat-back assembly.	<ol style="list-style-type: none"> 1. Check for visible signs of damage (dents, tears, deformation) of the seat back on the collision side. 2. Check harness and connectors for damage, and terminals for deformities. 3. If damaged—REPLACE the front seatback assembly.
(LH or RH) side air bag (satellite) sensor	REPLACE the side air bag (satellite) sensor on the collision side with new fasteners. (Repair the center pillar inner, etc. before installing new one if damaged.)	<ol style="list-style-type: none"> 1. Remove the side air bag (satellite) sensor on the collision side. Check harness connectors for damage, terminals for deformities, and harness for binding. 2. Check for visible signs of damage (dents, cracks, deformation) of the side air bag (satellite) sensor. 3. Install the side air bag (satellite) sensor to check fit. 4. If no damage is found, reinstall the side sir bag (satellite) sensor with new fasteners. 5. If damaged—REPLACE the side air bag (satellite) sensor with new fasteners.
Diagnosis sensor unit	REPLACE the diagnosis sensor unit with new fasteners.	<ol style="list-style-type: none"> 1. Check case and bracket for dents, cracks or deformities. 2. Check connectors for damage, and terminals for deformities. 3. If no damage is found, reinstall the diagnosis sensor unit with new fasteners. 4. If damaged—REPLACE the diagnosis sensor unit with new fasteners.
Seat belt pre-tensioner assembly	<ol style="list-style-type: none"> 1. Check if the seat belt can be extended smoothly. If the seat belt cannot be extended smoothly, <ul style="list-style-type: none"> - Check for deformities of the center pillar inner. - If the center pillar inner has no damage, REPLACE the seat belt pre-tensioner assembly. 2. Remove the seat belt pre-tensioner assembly on the collision side. Check harness cover and connectors for damage, terminals for deformities, and harness for binding. 3. Check for visible signs of damage (dents, cracks, deformation) of the seat belt pre-tensioner assembly. 4. Check seat belt adjuster for damage. 5. If no damage is found, reinstall the seat belt pre-tensioner assembly. 6. If damaged—REPLACE the seat belt pre-tensioner assembly with new fasteners. 	
Seat (with front side air bag)	REPLACE front seat-back assembly.	<ol style="list-style-type: none"> 1. Visually check the seat on the collision side. 2. Remove the seat on the collision side and check the following for damage and deformities. <ul style="list-style-type: none"> - Harness, connectors and terminals - Frame and recliner (for front and rear seat), and also adjuster and slides (for front seat) 3. If no damage is found, reinstall the seat. 4. If damaged—REPLACE the damaged seat parts using new fasteners. If the front seat back is damaged, the front seat back assembly must be replaced.
Center inner pillar	<ol style="list-style-type: none"> 1. Check the center inner pillar on the collision side for damage (dents, cracks, deformation). 2. If damaged—REPAIR the center inner pillar. 	
Trim/headlining	<ol style="list-style-type: none"> 1. Check for visible signs of damage (dents, cracks, deformation) of the interior trim on the collision side. 2. If damaged—REPLACE the damaged trim parts. 	